

# OMRON

i4L

## Robots

### User's Manual

i4-350L

i4-450L

i4-550L



I658-E-09

**NOTE**

All rights reserved. No part of this publication may be reproduced, stored in a retrieval system, or transmitted, in any form, or by any means, mechanical, electronic, photocopying, recording, or otherwise, without the prior written permission of OMRON.

No patent liability is assumed with respect to the use of the information contained herein. Moreover, because OMRON is constantly striving to improve its high-quality products, the information contained in this manual is subject to change without notice. Every precaution has been taken in the preparation of this manual. Nevertheless, OMRON assumes no responsibility for errors or omissions. Neither is any liability assumed for damages resulting from the use of the information contained in this publication.

**Trademarks**

EtherCAT® is registered trademark and patented technology, licensed by Beckhoff Automation GmbH, Germany.

Company names and product names in this document are the trademarks or registered trademarks of their respective companies.

**Copyrights**

Microsoft product screen shots reprinted with permission from Microsoft Corporation.

# Introduction

---

Thank you for purchasing the i4L robot.

This manual is OMRON's original instructions describing the setup, operation, and user maintenance of the product.

This manual contains IMPORTANT SAFETY INSTRUCTIONS. Please read this manual and make sure you understand the functionality and performance of the robot before attempting to use it.

SAVE THESE INSTRUCTIONS. Keep this manual in a safe place where it will be available for reference during operation.

## Intended Audience

This manual is intended for the following personnel, who must also have knowledge of factory automation (FA) systems and robotic control methods.

- Personnel in charge of introducing FA systems.
- Personnel in charge of designing FA systems.
- Personnel in charge of installing and maintaining FA systems.
- Personnel in charge of managing FA systems and facilities.

## Version Information

The information in this document describes features and functionality for i4L-series robots using the following hardware and software versions.

- Robot Controller Version: Revision B
- Robot Firmware Version: 6.102C
- Software Version: ACE 4.8.3

## Applicable i4L-series Models

This manual provides information for all Standard Control robot models.

When information varies between different robot models, details are provided. When information is common to all robot models, an illustration of a single robot model is typically shown.

## Units

All units are metric unless otherwise noted.

# Manual Information

## Page Structure

The following page structure is used in this manual.

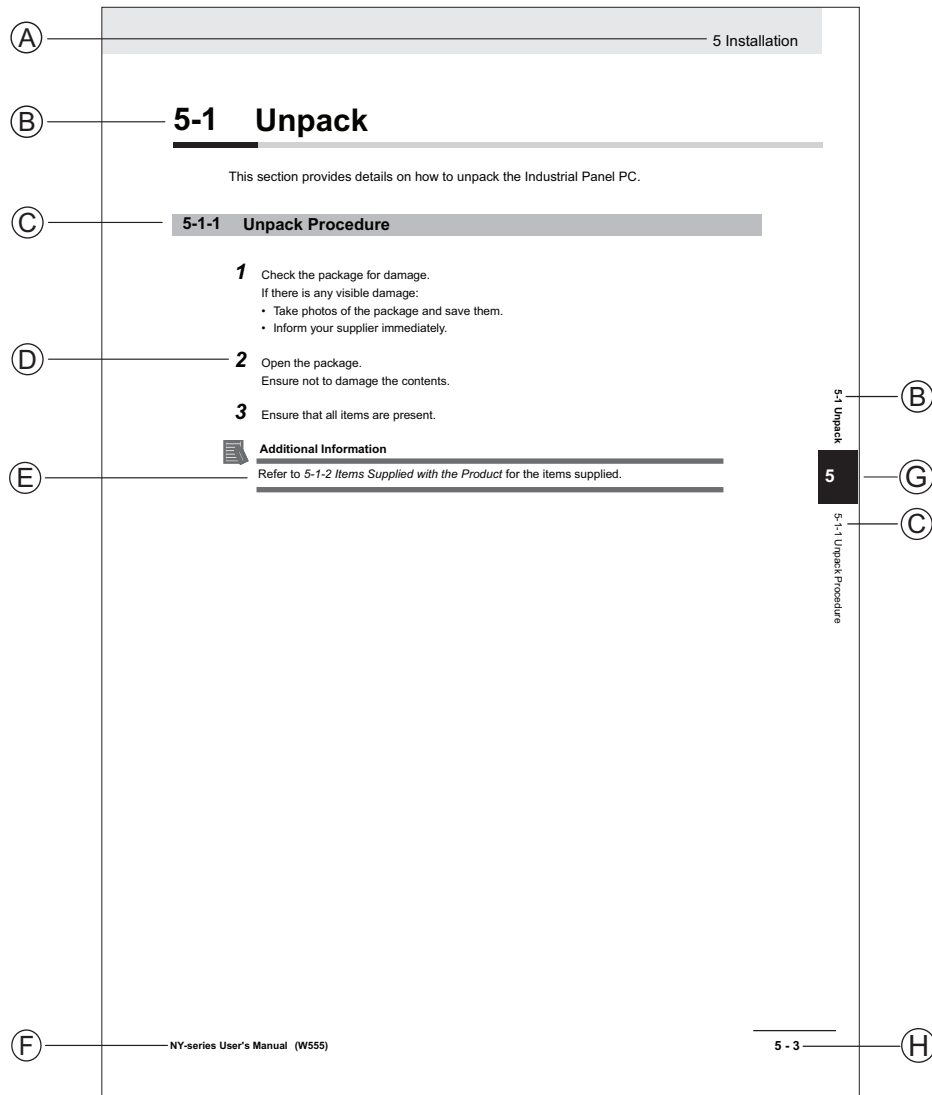

Note: This illustration is provided as a sample. It will not literally appear in this manual.

Item	Explanation	Item	Explanation
A	Level 1 heading	E	Special Information
B	Level 2 heading	F	Manual name
C	Level 3 heading	G	Page tab with the number of the main section
D	Step in a procedure	H	Page number

## Special Information

Special information in this manual is classified as follows:



---

### **Precautions for Safe Use**

---

Precautions on what to do and what not to do to ensure safe usage of the product.

---



---

### **Precautions for Correct Use**

---

Precautions on what to do and what not to do to ensure proper operation and performance.

---



---

### **Additional Information**

---

Additional information to read as required.

This information is provided to increase understanding or make operation easier.

---



---

### **Version Information**

---

Information on differences in specifications and functionality between different versions.

---



# Sections in this Manual

---

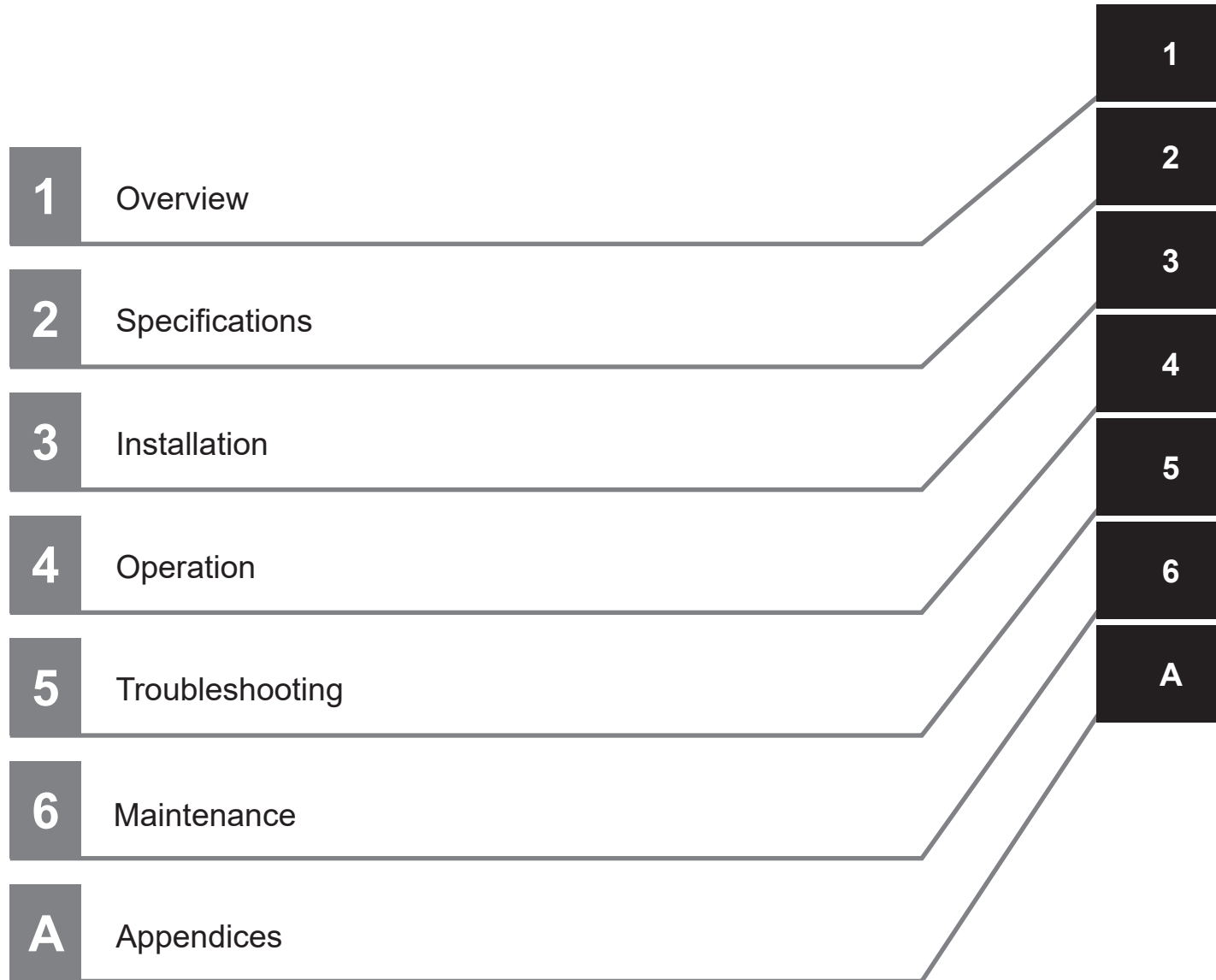

# CONTENTS

---

<b>Introduction .....</b>	<b>1</b>
Intended Audience .....	1
Version Information .....	1
Applicable i4L-series Models .....	1
Units .....	1
<b>Manual Information .....</b>	<b>2</b>
Page Structure .....	2
Special Information .....	3
<b>Sections in this Manual .....</b>	<b>5</b>
<b>Terms and Conditions Agreement.....</b>	<b>10</b>
Warranty and Limitations of Liability .....	10
Application Considerations .....	11
Disclaimers .....	11
<b>Safety Precautions.....</b>	<b>13</b>
Definition of Precautionary Information.....	13
Symbols .....	13
Dangers .....	14
Warnings.....	15
Cautions.....	18
<b>Precautions for Safe Use .....</b>	<b>20</b>
<b>Precautions for Correct Use .....</b>	<b>22</b>
<b>Regulations and Standards .....</b>	<b>24</b>
Directives .....	24
Standards .....	24
Conformance to KC Certification .....	24
Software Licenses and Copyrights .....	25
<b>Related Manuals.....</b>	<b>26</b>
<b>Glossary.....</b>	<b>27</b>
<b>Revision History.....</b>	<b>28</b>

## Section 1 Overview

---

<b>1-1 Intended Use .....</b>	<b>1-2</b>
<b>1-2 Robot Features.....</b>	<b>1-3</b>
1-2-1 Robot System.....	1-3
1-2-2 Basic Robot Components .....	1-4
1-2-3 Front Panel.....	1-7
1-2-4 Connectors and Ports .....	1-8
<b>1-3 Information Labels.....</b>	<b>1-11</b>
1-3-1 Robot Label .....	1-11
1-3-2 Controller Label.....	1-12
<b>1-4 Robot Configurations .....</b>	<b>1-13</b>

1-4-1	i4-350L .....	1-13
1-4-2	i4-450L .....	1-13
1-4-3	i4-550L .....	1-13
1-4-4	i4-550L (350 mm Z).....	1-14
1-4-5	Mounting and Cabling Options .....	1-14
<b>1-5</b>	<b>Model Numbers .....</b>	<b>1-15</b>
1-5-1	Robot Model Numbers .....	1-15
1-5-2	Controller Model Numbers .....	1-15
<b>1-6</b>	<b>Optional Hardware .....</b>	<b>1-16</b>
1-6-1	IO Blox .....	1-16
1-6-2	T20 Pendant.....	1-16
1-6-3	IPC Application Controller .....	1-17
1-6-4	XIO Termination Block.....	1-17
1-6-5	Optional Cables.....	1-19
1-6-6	Camera Mounting Kit .....	1-20
1-6-7	Bellows Kit.....	1-21
1-6-8	Pneumatic Valve Kit .....	1-22
1-6-9	Power Supply Kits.....	1-23

## Section 2 Specifications

<b>2-1</b>	<b>Physical Specifications .....</b>	<b>2-2</b>
2-1-1	Robot Overall Dimensions .....	2-2
2-1-2	Mounting Flange Dimensions.....	2-4
2-1-3	Tool Flange Dimensions .....	2-5
2-1-4	Front Panel Dimensions .....	2-5
2-1-5	Camera Mounting Bracket Dimensions.....	2-6
2-1-6	Robot Work Envelope Dimensions.....	2-6
2-1-7	Robot Weights.....	2-8
<b>2-2</b>	<b>Performance Specifications.....</b>	<b>2-9</b>
2-2-1	General Performance Information .....	2-9
2-2-2	Stopping Distances and Times.....	2-10
2-2-3	Lateral Push Force .....	2-13
2-2-4	Joint 4 Inertia vs. Acceleration .....	2-13
<b>2-3</b>	<b>Electrical Specifications.....</b>	<b>2-15</b>
2-3-1	Power Supply Specifications .....	2-15
2-3-2	XIO and TIO Connector I/O Specifications .....	2-15
2-3-3	Belt Encoder Specifications .....	2-16
<b>2-4</b>	<b>Environmental Specifications.....</b>	<b>2-17</b>
<b>2-5</b>	<b>Other Specifications .....</b>	<b>2-18</b>
2-5-1	Maximum Kinetic Energy .....	2-18
2-5-2	Ethernet Communication Specifications .....	2-18
2-5-3	EtherCAT Communication Specifications.....	2-18
2-5-4	PROFINET Specifications .....	2-19
2-5-5	Connector and Port Specifications .....	2-19
2-5-6	Mounting Hardware and Torques .....	2-20

## Section 3 Installation

<b>3-1</b>	<b>Robot Installation Procedure.....</b>	<b>3-3</b>
<b>3-2</b>	<b>Mounting the Robot.....</b>	<b>3-5</b>
3-2-1	Robot Mounting Surface .....	3-5
3-2-2	Mounting Procedure.....	3-5
<b>3-3</b>	<b>Installing End-of-Arm Tooling.....</b>	<b>3-7</b>
<b>3-4</b>	<b>Installing Optional Equipment.....</b>	<b>3-8</b>
3-4-1	Mounting External Equipment to the Robot .....	3-8

3-4-2	USER Connector Wiring .....	3-9
3-4-3	Bellows Kit Installation Procedure .....	3-9
3-4-4	Pneumatic Valve Kit Installation Procedure.....	3-16
3-4-5	Control Power Kit Connections .....	3-20
3-4-6	High Power Kit Connections .....	3-20
<b>3-5</b>	<b>Adjustable Hardstops.....</b>	<b>3-21</b>
3-5-1	Joint 1 Adjustable Hardstops .....	3-22
3-5-2	Joint 2 Adjustable Hardstops .....	3-22
3-5-3	Joint 3 Adjustable Hardstop .....	3-22
<b>3-6</b>	<b>System Cable Installation .....</b>	<b>3-24</b>
3-6-1	System Cable Overview.....	3-24
3-6-2	System Cable Installation Procedure .....	3-28
<b>3-7</b>	<b>Connecting Digital I/O .....</b>	<b>3-29</b>
3-7-1	XIO Connector Signals and Wiring .....	3-29
3-7-2	TIO Connector Signals and Wiring.....	3-33
3-7-3	IO Blox Connections .....	3-35
<b>3-8</b>	<b>Installing Safety Equipment.....</b>	<b>3-37</b>
3-8-1	Installing the Front Panel .....	3-37
3-8-2	Safety Circuits .....	3-38
<b>3-9</b>	<b>Setting the EtherCAT Node ID .....</b>	<b>3-45</b>
3-9-1	EtherCAT Node ID Setting Example .....	3-45
<b>3-10</b>	<b>Supplying Power and Ground .....</b>	<b>3-47</b>
3-10-1	Grounding the System .....	3-47
3-10-2	Power Connections .....	3-47
<b>3-11</b>	<b>Verifying Installation.....</b>	<b>3-50</b>
3-11-1	Mechanical Checks .....	3-50
3-11-2	System Cable Checks.....	3-50
3-11-3	Safety Equipment Checks.....	3-50
3-11-4	Switch Position Checks.....	3-52

## Section 4 Operation

---

<b>4-1</b>	<b>Connecting to the Robot.....</b>	<b>4-2</b>
4-1-1	Initial Connection Procedure .....	4-2
<b>4-2</b>	<b>Payload and Acceleration Considerations .....</b>	<b>4-4</b>
<b>4-3</b>	<b>Robot Control Modes .....</b>	<b>4-5</b>
4-3-1	Manual Mode .....	4-5
4-3-2	Automatic Mode .....	4-5
<b>4-4</b>	<b>Enabling and Disabling the Robot .....</b>	<b>4-7</b>
4-4-1	Robot High Power Operations .....	4-7
<b>4-5</b>	<b>LED Indicators.....</b>	<b>4-9</b>
4-5-1	Visual Status LED Indicator.....	4-9
4-5-2	PROFINET Device Identification LED Indicators .....	4-9
4-5-3	Front Panel LED Indicators .....	4-10
<b>4-6</b>	<b>Brake Operation .....</b>	<b>4-11</b>
4-6-1	Built-in Brake Release Button .....	4-11
4-6-2	Remote Brake Release .....	4-12
<b>4-7</b>	<b>Manually Jogging the Robot.....</b>	<b>4-13</b>
<b>4-8</b>	<b>Robot Positioning .....</b>	<b>4-14</b>
4-8-1	Joint Zero Position .....	4-14
4-8-2	Ready Position .....	4-14
4-8-3	Right-Left Arm Configurations .....	4-15
4-8-4	Collision Avoidance .....	4-15

## Section 5 Troubleshooting

---

<b>5-1</b>	<b>Fault Detection</b> .....	<b>5-2</b>
<b>5-2</b>	<b>Failure to Power ON</b> .....	<b>5-3</b>
<b>5-3</b>	<b>Emergency Stop Troubleshooting</b> .....	<b>5-4</b>
<b>5-4</b>	<b>Error Messages</b> .....	<b>5-5</b>

## Section 6 Maintenance

---

<b>6-1</b>	<b>Periodic Maintenance</b> .....	<b>6-2</b>
6-1-1	Periodic Maintenance Overview .....	6-2
6-1-2	Checking Safety Functions .....	6-2
6-1-3	Checking Fastener Torques .....	6-3
6-1-4	Checking Safety and Warning Labels .....	6-4
6-1-5	Checking for Lubricant Leaks.....	6-4
6-1-6	Lubricating Joint 3 .....	6-5
6-1-7	Replacing Encoder Backup Batteries.....	6-6
6-1-8	Cleaning the Robot .....	6-7
6-1-9	Bellows Inspection .....	6-8
<b>6-2</b>	<b>Non-periodic Maintenance</b> .....	<b>6-9</b>
6-2-1	Replacing the Tool Flange.....	6-9

## Appendices

---

<b>A-1</b>	<b>Unpacking and Inspecting the Robot</b> .....	<b>A-2</b>
A-1-1	Before Unpacking the Robot .....	A-2
A-1-2	Unpacking the Robot.....	A-2
<b>A-2</b>	<b>Repacking the Robot for Transport</b> .....	<b>A-4</b>
<b>A-3</b>	<b>Transportation and Storage Considerations</b> .....	<b>A-5</b>
<b>A-4</b>	<b>Cable Pinouts</b> .....	<b>A-6</b>
A-4-1	XSYSTEM Cable Pinouts.....	A-6
A-4-2	XBELTIO Adapter Cable Pinouts .....	A-7
A-4-3	Belt Encoder Y-adapter Cable Pinouts.....	A-8
<b>A-5</b>	<b>I/O Signal Numbering</b> .....	<b>A-10</b>
A-5-1	Input Signal Numbering.....	A-10
A-5-2	Output Signal Numbering.....	A-10
<b>A-6</b>	<b>Parts List</b> .....	<b>A-11</b>

## Index

---

# Terms and Conditions Agreement

## Warranty and Limitations of Liability

### Warranty

#### ● Exclusive Warranty

Omron's exclusive warranty is that the Products will be free from defects in materials and workmanship for a period of twelve months from the date of sale by Omron (or such other period expressed in writing by Omron). Omron disclaims all other warranties, expressed or implied.

#### ● Limitations

OMRON MAKES NO WARRANTY OR REPRESENTATION, EXPRESS OR IMPLIED, ABOUT NON-INFRINGEMENT, MERCHANTABILITY OR FITNESS FOR A PARTICULAR PURPOSE OF THE PRODUCTS. BUYER ACKNOWLEDGES THAT IT ALONE HAS DETERMINED THAT THE PRODUCTS WILL SUITABLY MEET THE REQUIREMENTS OF THEIR INTENDED USE.

Omron further disclaims all warranties and responsibility of any type for claims or expenses based on infringement by the Products or otherwise of any intellectual property right.

#### ● Buyer Remedy

Omron's sole obligation hereunder shall be, at Omron's election, to (i) replace (in the form originally shipped with Buyer responsible for labor charges for removal or replacement thereof) the non-complying Product, (ii) repair the non-complying Product, or (iii) repay or credit Buyer an amount equal to the purchase price of the non-complying Product; provided that in no event shall Omron be responsible for warranty, repair, indemnity or any other claims or expenses regarding the Products unless Omron's analysis confirms that the Products were properly handled, stored, installed and maintained and not subject to contamination, abuse, misuse or inappropriate modification. Return of any Products by Buyer must be approved in writing by Omron before shipment. Omron Companies shall not be liable for the suitability or unsuitability or the results from the use of Products in combination with any electrical or electronic components, circuits, system assemblies or any other materials or substances or environments. Any advice, recommendations or information given orally or in writing, are not to be construed as an amendment or addition to the above warranty.

See <http://www.omron.com/global/> or contact your Omron representative for published information.

### Limitations of Liability

OMRON COMPANIES SHALL NOT BE LIABLE FOR SPECIAL, INDIRECT, INCIDENTAL, OR CONSEQUENTIAL DAMAGES, LOSS OF PROFITS OR PRODUCTION OR COMMERCIAL LOSS IN ANY WAY CONNECTED WITH THE PRODUCTS, WHETHER SUCH CLAIM IS BASED IN CONTRACT, WARRANTY, NEGLIGENCE OR STRICT LIABILITY. Further, in no event shall liability of Omron Companies exceed the individual price of the Product on which liability is asserted.

## Application Considerations

### Suitability for Use

---

Omron Companies shall not be responsible for conformity with any standards, codes or regulations which apply to the combination of the Product in the Buyer's application or use of the Product. At Buyer's request, Omron will provide applicable third party certification documents identifying ratings and limitations of use which apply to the Product. This information by itself is not sufficient for a complete determination of the suitability of the Product in combination with the end product, machine, system, or other application or use. Buyer shall be solely responsible for determining appropriateness of the particular Product with respect to Buyer's application, product or system. Buyer shall take application responsibility in all cases.

NEVER USE THE PRODUCT FOR AN APPLICATION INVOLVING SERIOUS RISK TO LIFE OR PROPERTY WITHOUT ENSURING THAT THE SYSTEM AS A WHOLE HAS BEEN DESIGNED TO ADDRESS THE RISKS, AND THAT THE OMRON PRODUCT(S) IS PROPERLY RATED AND INSTALLED FOR THE INTENDED USE WITHIN THE OVERALL EQUIPMENT OR SYSTEM.

### Programmable Products

---

- Omron Companies shall not be responsible for the user's programming of a programmable Product, or any consequence thereof.
- Omron Companies shall not be responsible for the operation of the user accessible operating system (e.g. Windows, Linux), or any consequence thereof.

## Disclaimers

### Performance Data

---

Data presented in Omron Company websites, catalogs and other materials is provided as a guide for the user in determining suitability and does not constitute a warranty. It may represent the result of Omron's test conditions, and the user must correlate it to actual application requirements. Actual performance is subject to the Omron's Warranty and Limitations of Liability.

### Change in Specifications

---

Product specifications and accessories may be changed at any time based on improvements and other reasons. It is our practice to change part numbers when published ratings or features are changed, or when significant construction changes are made. However, some specifications of the Product may be changed without any notice. When in doubt, special part numbers may be assigned to fix or establish key specifications for your application. Please consult with your Omron's representative at any time to confirm actual specifications of purchased Product.

## **Errors and Omissions**

---

Information presented by Omron Companies has been checked and is believed to be accurate; however, no responsibility is assumed for clerical, typographical or proofreading errors or omissions.



# Safety Precautions

## Definition of Precautionary Information





The following notation is used in this manual to provide precautions required to ensure safe usage of the i4L robot. The safety precautions that are provided are extremely important to safety.

Always read and heed the information provided in all safety precautions.

The following notation is used.

 <b>DANGER</b>	Identifies an imminently hazardous situation which, if not avoided, is likely to result in serious injury, and might result in fatality or severe property damage.
 <b>WARNING</b>	Indicates a potentially hazardous situation which, if not avoided, could result in death or serious injury. Additionally, there may be severe property damage.
 <b>CAUTION</b>	Indicates a potentially hazardous situation which, if not avoided, may result in minor or moderate injury, or property damage.

## Symbols

	The circle and slash symbol indicates operations that you must not do. The specific operation is shown in the circle and explained in text. This example indicates prohibiting disassembly.
	The triangle symbol indicates precautions (including warnings). The specific operation is shown in the triangle and explained in text. This example indicates a precaution for electric shock.
	The triangle symbol indicates precautions (including warnings). The specific operation is shown in the triangle and explained in text. This example indicates a general precaution.
	The filled circle symbol indicates operations that you must do. The specific operation is shown in the circle and explained in text. This example shows a general precaution for something that you must do.
	The triangle symbol indicates precautions (including warnings). The specific operation is shown in the triangle and explained in text. This example indicates a precaution for high temperatures.

## Dangers

# DANGER

### General

An i4L robot can cause serious injury or death, or damage to itself and other equipment, if the following safety precautions are not observed:

- All personnel who install, operate, teach, program, or maintain the system must read this guide, read the *Robot Safety Guide (Cat. No. I590)*, and complete a training course for their responsibilities in regard to the robot.
- All personnel who design the robot system must read this guide, read the *Robot Safety Guide (Cat. No. I590)*, and must comply with all local and national safety regulations for the location in which the robot is installed.
- The robot system must not be used for purposes other than described in *1-1 Intended Use* on page 1-2. Contact your local OMRON support if you are not sure of the suitability for your application.
- The user is responsible for providing safety barriers around the robot to prevent anyone from accidentally coming into contact with the robot when it is in motion.
- Power to the robot and its power supply must be locked out and tagged out before any maintenance is performed.
- When the robot or robotic equipment is not investigated in conjunction with a system work cell, the instructions shall call attention to the following: the interlocked portion of barrier shall be installed, applied, and maintained so that it has the capability of being easily unlocked from the inside of the safeguarded space, with or without power available, when the possibility of full body access exists.



i4L robots are not collaborative robots. They require a dedicated work area that will prevent personnel from coming into contact with them during operation.

The normal and intended use of these robots does not create hazards.

These robots have been designed and constructed in accordance with the relevant requirements of IEC 60204-1.

These robots are intended for use in parts assembly and material handling for payloads up to 5.0 kg.

Refer to the *Robot Safety Guide (Cat. No. I590)* for details on the intended use of our robots.

These robots are intended for industrial use only.

Perform a risk assessment before using.

These robots are not intended for:

- Use in the presence of ionizing or non-ionizing radiation.
- Use in potentially explosive atmospheres.
- Use in medical or life saving applications.
- Use in a residential setting.



Any change to the robot can lead to loss in safety or functionality. It is the user's responsibility to perform a risk assessment for the whole (modified) robot after any such changes and to confirm that all safety features of the robot are operational.



### Installation

The robot system must be installed with user-supplied interlock barriers. The interlocked barriers must open the E-Stop circuit in the event of personnel attempting to enter the work cell when High Power is enabled. Failure to install suitable guarding or interlocks could result in injury or death. We strictly prohibit installation, commissioning, or operation of any robot without adequate safeguards. These must be compliant with applicable local and national standards.



The placement of safety controls shall avoid requiring a person to enter a hazardous area to actuate them.



Controls shall be located outside of the safeguarded space, except for certain controls such as emergency stops or a teach pendant, where based on a risk assessment they may be located within the safeguarded space.



After installing the robot, you must test it before you use it for the first time. Failure to do this could cause death, serious injury, or equipment damage.



Failure to ground robot-mounted equipment or tooling that uses hazardous voltages could lead to injury or fatality of a person touching the end-effector during an electrical fault.



Any High Power push-buttons must be installed outside of the robot's workspace.



## Warnings

### WARNING

#### General

The instructions for operation, installation, and maintenance given in this document must be strictly observed.



If air pressure is present, disconnect it from the robot when servicing end-of-arm tooling or other pneumatic components to prevent unsecured pneumatic air lines from accidentally injuring personnel.



Do not move the robot links if the robot is not secured. Failure to comply could result in the robot falling and causing either personnel injury or property damage.











#### Installation

Ensure that installation and post-installation checks of the product are performed by personnel in charge who possess a thorough understanding of the machinery to be installed.

















Ensure compliance with all local and national safety and electrical codes for the installation and operation of the robot system.







Provide appropriately-sized Branch Circuit Protection and Lockout / Tagout Capability in accordance with the National Electrical Code and any local codes.	
Always use proper lifting technique when lifting the robot. Failure to comply could result in the robot falling and causing either personnel injury or equipment damage.	
If you supply your own Front Panel, its design must comply with the requirements of IEC 60204-1 and ISO 13849. The E-Stop's push button must comply with ISO 13850 (Clause 5.5.2).	
Disabling the High Power button violates IEC 60204-1. Do not alter its functionality.	
If a robot is mounted to a surface with inadequate stiffness, damage to the z-axis quill or other mechanical components can result from excessive oscillation during operation.	
The robot's center of mass can cause the robot to fall over if the robot is not properly secured with the mounting bolts.	
The robot must be installed to avoid interference with buildings, structures, utilities, other machines and equipment that may create trapping or pinch points. It must be installed in accordance with Standard for Robots and Robotic Devices – Safety Requirements for Industrial Robots – Part 2: Robot Systems and Integration, ISO 10218-2.	
Ensure that interconnecting cables or pneumatic lines are routed away from the robot workspace.	
To reduce the risk of fire or electric shock, install the robot in a controlled environment relatively free of contaminants.	

## Operation

Before starting the operation of equipment, always confirm that the safety equipment of the robot works properly. If a malfunction of the safety equipment is detected, follow the troubleshooting procedure.	
Use the total weight of the end-of-arm tooling and the payload to stay within the payload rating of the robot. Ensure that the system never exceeds that maximum payload.	
Perform a full risk assessment which includes the end-of-arm tooling and any payload to prevent crushing, shearing, payload ejection, entanglement, stabbing or puncture hazard.	
Releasing a brake may cause the quill, tool flange, end-of-arm tooling, and payload to drop. To prevent possible injury to personnel or damage to the equipment, make sure that the equipment is supported when releasing the brake and verify that the end-of-arm tooling and payload are clear of all obstructions.	
All signals that pass-through the USER connectors are not associated with any robot controls, emergency stop circuits, or robot power. Implement appropriate safety measures to ensure that these signals are not active during emergency stop conditions or while the robot is powered OFF.	

In Automatic mode, the robot can move unexpectedly. Ensure all personnel remain clear of the cell when Automatic mode is enabled.	
If an operator is going to be in the work cell with the switch in Manual mode, the operator must carry an enabling device such as the T20 pendant.	
Whenever possible, perform Manual mode operations with all personnel outside the workspace.	
The stopping time and distance, or angle, of a robot joint from initiation of a stop signal is not negligible and must be taken into account when designing and applying safeguarding devices.	
Never connect or disconnect system cables while power is applied to the robot. Failure to comply may cause unexpected behavior and can result in personnel injury and equipment damage.	
Never run a robot system with all jumpers installed. This would leave the system with no E-Stops.	
Do not use the robot in hazardous environments (explosive gas, and oil mist).	
The robot shall be operated within its specified temperature range to ensure proper operation.	
The robot's physical hardstop devices are not intended to withstand repeated use and if this occurs, the hardstop may become damaged. Implement proper programming and configuration of joint range limits to prevent hardstop impacts.	

## Maintenance

Do not use organic solvents to clean any part of the robot unless directed in the cleaning instructions. Organic solvents might damage electronics resulting in an unsafe operating state that could cause injury or damage to equipment.	
You must perform the Lockout and Tagout procedure prior to servicing the robot.	
The access covers on the robot are not interlocked. You must turn OFF and disconnect the power before the covers of the robot are removed.	
The procedures and replacement of the parts mentioned in this manual must be performed only by the skilled or instructed persons.	

## Cybersecurity

To maintain the security and reliability of the system, a robust cybersecurity defense program should be implemented, which may include some or all of the following:

### Anti-virus protection

- Install the latest commercial-quality anti-virus software on the computer connected to the control system and keep the software and virus definitions up-to-date.
- Scan USB drives or other external storage devices before connecting them to control systems and equipment.

### Security measures to prevent unauthorized network access

- Install physical controls so that only authorized personnel can access control systems and equipment.
- Reduce connections to control systems and equipment via networks to prevent access from untrusted devices.
- Install firewalls to block unused communications ports and limit communication between systems. Limit access between control systems and systems from the IT network.
- Control remote access and adopt multifactor authentication to devices with remote access to control systems and equipment.
- Set strong password policies and monitor for compliance frequently.

### Data input and output protection

- Backup data and keep the data up-to-date periodically to prepare for data loss.
- Validate backups and retention policies to cope with unintentional modification of input/output data to control systems and equipment.
- Validate the scope of data protection regularly to accommodate changes.
- Check validity of backups by scheduling test restores to ensure successful recovery from incidents.
- Safety design, such as emergency shutdown and fail-soft operations in case of data tampering and incidents.

### Additional recommendations

- When using an external network environment to connect to an unauthorized terminal such as a SCADA, HMI or to an unauthorized server may result in network security issues such as spoofing and tampering.
- You must take sufficient measures such as restricting access to the terminal, using a terminal equipped with a secure function, and locking the installation area by yourself.
- When constructing network infrastructure, communication failure may occur due to cable disconnection or the influence of unauthorized network equipment.
- Take adequate measures, such as restricting physical access to network devices, by means such as locking the installation area.
- When using devices equipped with an SD Memory Card, there is a security risk that a third party may acquire, alter, or replace the files and data in the removable media by removing or unmounting the media.
- Please take sufficient measures, such as restricting physical access to the Controller or taking appropriate management measures for removable media, by means of locking and controlling access to the installation area.
- Educate employees to help them identify phishing scams received via email on systems that will connect to the control network.



## Cautions



---

Always physically disconnect the robot from the EtherCAT network before disabling its EtherCAT communication.



---

The design and installation of the complete system must comply with the safety standards and regulations in the country of use. The integrators of the robot should understand the safety laws and regulations in their countries and prevent major hazards from occurring in the complete system.

---



# Precautions for Safe Use

- The Joint 3 quill and the tool flange are not grounded to protective earth. If hazardous voltages are present at any user-supplied robot-mounted equipment or tooling, you must install a ground connection from that equipment or tooling to the ground point on the robot base.
- This equipment must be shipped and stored in a temperature-controlled environment, within the range  $-25$  to  $+55^{\circ}\text{C}$ . The recommended humidity range is 5 to 90%, non-condensing. It should be shipped and stored in the supplied packaging, which is designed to prevent damage from normal shock and vibration.
- Fieldbus communications are not secure. Additional measures must be taken if compliance with security standards is required.
- Output 8 can be assigned to indicate the robot's High Power state. When High Power is enabled, this output will turn ON. When High Power is not enabled, this output will be OFF. This is not a safety-rated means of indicating a High Power state and should only be used for monitoring the robot status. Use the ACE software to make this configuration if needed.
- Do not apply 48 VDC power until all installation steps are complete and verified and all safety measures are in place.
- High power cannot be enabled unless all safety circuits are satisfied.
- The LED indicator does not reflect the robot's High Power status. To see the robot's High Power status, use the Front Panel indicator or a user-supplied indicator connected to the XFP connector.
- The braking mechanism operates passively. If 24 VDC Control Power is removed from the system, the brake mechanism will automatically activate. 24 VDC Control Power must be supplied to release the brake. To prevent possible damage to the equipment, remove any payload from the end-of-arm tooling, make sure that Joint 3 is supported while releasing the brake, and verify that the end-of-arm tooling or other installed equipment is clear of all obstructions.
- The High Power indicator must be operational to satisfy safety requirements.
- You can contribute to resource conservation and protecting the environment by the proper disposal of Waste Electronics and Electrical Equipment (WEEE). All electrical and electronic products should be disposed of separately from the municipal waste system according to local ordinances using designated collection facilities.



- Dispose of any battery that has been dropped or otherwise subjected to excessive shock. Batteries that have been subjected to shock may leak if they are used.
- Batteries may leak, rupture, heat, or ignite. Never short-circuit, charge, disassemble, heat, or incinerate a battery or subject it to strong shock.
- Any person who programs, teaches, operates, maintains, or repairs robots or robot systems shall be trained and can demonstrate competence to safely perform the assigned task.
- Fieldbus communications are not secure. Additional measures must be taken if compliance with security standards is required
- Any person who programs, teaches, operates, maintains, or repairs robots or robot systems shall be trained on responding to emergency or abnormal situations.
- Do not connect user-supplied Manual / Automatic contacts or other control signals in parallel with the Front Panel switch contact. This would violate the Single Point of Control principle and might allow Automatic mode to be selected while an operator is in the cell.

- Acoustic emission from these robots may be up to 70 dB (A) at 1 m distance under worst-case conditions. Typical values will be lower, depending on payload, speed, acceleration, and mounting. Appropriate safety measures should be taken, such as ear protection and display of a warning sign.
- Any moving robot requires some distance to stop. This requires more distance at high operating speeds or heavier payloads. When stopping a robot, make sure that there is no interference with other equipment.
- Do not expose the shipping container to excessive shock and vibration. This could damage the robot.
- Using improper lubrication products on the robot may damage it.
- After an operator places the robot in Manual mode using the Front Panel key switch, they should remove the key for safety purposes.
- If the supplied Front Panel is not used, a High Power indicator light must be present in the system. This indicator light must be amber in color. It must be either mounted to the robot or integrated into the work cell where it is visible from all approaches or entry points.
- If a supplementary audible means of robot operation is provided, it shall exceed the ambient noise at the end-use application.
- You can burn yourself. Do not touch the robot after it has been running at high ambient temperatures or at fast cycle times (over 60 cycles per minute). The robot surface temperature can exceed 85° C.
- During manual operation, ensure all persons are a safe distance away from the robot work envelope.
- The robot can be lifted by hand. Only use the base and inner link when lifting the robot. Never maneuver the robot using the quill or flyover assemblies.
- To stop the robot in an emergency, press any E-stop button and then follow the internal procedures of your company or organization defined for an emergency situation.
- If a fire occurs on the robot, use a CO<sub>2</sub> type fire extinguisher.
- In case of entrapment of a person by the robot or any other emergency or abnormal situation, you can manually move the inner and outer links to a safe position while 48 VDC High Power is disabled. A brake device prevents Joints 3 and 4 from moving when High Power is disabled and can only be released while 24 VDC Control Power is present.
- Prior to placing the robot in Automatic Mode, all safeguards must be returned to their safe state.
- After the robot is placed in Manual mode using the Front Panel key switch, the key should be removed for safety purposes.

# Precautions for Correct Use

---

- Depending on your application, some latency may occur between devices that communicate through the IN/1, OUT/2, and ports. Special consideration should be made when connecting devices to these ports that require time-critical operations.
- Robot motion is not possible until High Power is supplied and has been enabled.
- Control power must be present before High Power can be enabled.
- The T20 pendant can only control the robot it is directly connected to.
- Either a Front Panel or equivalent circuits are required to enable High Power to the robot.
- If the Front Panel High Power ON / OFF indicator fails, you might incorrectly assume that High Power is OFF, and the robot is safe. To prevent this, a failed indicator causes an error (-924) \*Front panel HIGH POWER lamp failure\* and locks out the High Power enabling until you replace the indicator. Refer to the *V+ User's Manual (Cat. No. I671)* for more information about error handling. Refer to *High Power Indicator Check Procedure* on page 3-51 for information about High Power indicator operation verification.
- It is recommended to use a properly secured, 18 mm (minimum) thick steel plate with a maximum surface roughness of 25 µm as a robot mounting surface.
- The mounting surface should be clean and prepared according to the information provided in this document before attempting to mount the robot.
- Do not over-tighten the tool flange setscrew. This will cause off-center alignment of the tool flange on the quill.
- Always reduce joint motion limits with software settings in the robot configuration area when hard-stops are used to restrict range of motion.
- Never loosen or remove the quill clamp collar while the z-axis brake is released.
- If Teach Pendant cabling is installed, the jumper plug or the Teach Pendant must be connected to satisfy safety circuits and allow High Power to be enabled.
- Do not disable or bypass the High Power button. This will violate IEC 60204-1.
- Operating the robot outside of the payload and speed constraints described in this document can damage or reduce the service life of the z-axis quill.
- If a Front Panel is not present, the High Power indicator and High Power button signals can be accessed with the XFP system cable connector.
- Attempting to release the brake while High Power is ON will automatically disable High Power. If the robot is moving, this will cause it to stop abruptly.
- If no controller(s) is detected, check the Ethernet network and cables and ensure that a network connection is available between the robot controller and the PC.
- Only replace items on the robot system with the parts supplied by OMRON.
- Only use the recommended grease on the joint 3 quill. Use THK AFF Grease (part number 20950-000). Refer to the provided Safety Data Sheet for proper handling.
- When removing and replacing the tool flange, you must reinstall it in the same position to avoid losing the calibration for the robot.
- Use surge suppression when switching inductive loads such as relays to prevent damage to the output circuits.
- Any externally mounted equipment is considered robot payload. Consideration to the payload attached to the Tool Flange should be made when mounting external equipment to the robot.
- If the robot has a bottom Primary Interface Panel orientation, do not temporarily set the robot upright on a flat surface because this can damage the Primary Interface Panel connectors.

- Avoid rotating the quill / Joint 4 when the brake is released. This could result in an out-of-range condition and may prevent program execution.
- All fastener torque values provided must be applied within  $\pm 5\%$ .
- Keep a minimum of 300 mm clearance from the Primary Interface Panel to allow for switch and cable connection access.
- The z-axis stroke is reduced when bellows are present. Bellows reduce the travel by 27 mm (180 mm quill length) / 53 mm (350 mm quill length) in the z-axis retracted position and 27 mm (180 mm quill length) / 53 mm (350 mm quill length) in the z-axis extended position. Always adjust joint motion limits with software settings in the robot configuration area when bellows are installed to restrict range of motion.

# Regulations and Standards

## Directives

The robot complies with the following Directives.

- 2006/42/EC  
Machinery Directive
- 2014/30/EU  
EMC Directive

## Standards

The robot system conforms to the following Standards.

- EN ISO 12100  
Safety of Machinery  
General Principles for Design  
Risk Assessment and Reduction
- EN ISO 13849-1  
Safety of Machinery  
Safety Related Parts of Control Systems SRP/CS – Part 1
- EN ISO 10218-1  
Robots for industrial environments  
Safety requirements, Part 1: Robot
- UL 1740  
Standard for Robots and Robotic Equipment
- EN 60204-1  
Safety of Machinery  
Electrical equipment of machines, Part 1 General Requirements
- EN 61000-6-2  
EMC, Part 6-2: Immunity Emissions Standard for Industrial Environments
- EN 61000-6-4  
EMC, Part 6-4: Emissions Standard for Industrial Environments
- CAN/CSA Z434  
Industrial Robots and Robot Systems
- KN 61000 6-2  
EMC, Part 6-2: Generic standards - Immunity for Industrial Environments
- KN 61000 6-4  
EMC, Part 6-4: Generic standards - Emission Standard for Industrial Environments

## Conformance to KC Certification

When you use this product in South Korea, observe the following precautions.

### 사 용 자 안 내 문

이 기기는 업무용 환경에서 사용할 목적으로 적합성평가를 받은 기기로서 가정용 환경에서 사용하는 경우 전파간섭의 우려가 있습니다.

This product meets the electromagnetic compatibility requirements for business use. There is a risk of radio interference when this product is used in home.

## Software Licenses and Copyrights

This product incorporates certain third party software. The license and copyright information associated with this software is available at [http://www.fa.omron.co.jp/nj\\_info\\_e/](http://www.fa.omron.co.jp/nj_info_e/).

# Related Manuals

Use the following related manuals for reference.

Manual Title	Description
Automated Control Environment (ACE) Version 4 User's Manual (Cat. No. I633)	Instruction for the use of the ACE Version 4 software.
IPC Application Controller User's Manual (Cat. No. I632)	Describes the IPC Application Controller.
T20 Pendant User's Manual (Cat. No. I601)	Describes the setup, operation, and user maintenance for the Teaching Pendant T20.
Robot Safety Guide (Cat. No. I590)	Describes how to use the OMRON robot safely.
V+ User's Manual (Cat. No. I671)	Provides a description of the V+ programming language and functionality.
V+ Keyword Reference Manual (Cat. No. I672)	Provides reference to V+ Keyword use and functionality.
Industrial Robot Fieldbus Configuration User's Guide (Cat. No. M130)	Provides information about industrial fieldbus configurations for OMRON Industrial Robots.

# Glossary

Term / Abbreviation	Description
Application Controller	Industrial PC that provides additional functionality to the robot to execute PackManager and Robot Vision Manager applications.
Automatic Mode	Operating state of the robot during normal conditions. In this mode, program execution will control the robot up to the maximum allowable speed.
Control Power	24 VDC supply that energizes control and other non-servo motor circuits.
End-of-arm Tooling	Any device mounted to the robot's tool flange intended for performing work during robot operation.
Emergency Stop	An action or device used to immediately stop the robot. This may be referred to as emergency stop, E-stop, or ESTOP.
Flyover	The cable assembly that connects the robot base to the outer link.
Hardstop	Physical limit that restricts the range of motion for a robot axis.
High Power	48 VDC supply that energizes all internal servo motors to allow robot motion.
Joint	Mechanical robot component that connects its moving parts.
LED Indicator	Multi-colored light on top of the outer link that provides a visual indication of the robot operating state.
Link	Mechanical robot component that moves in a radial motion.
Manual Mode	Operating state of the robot during commissioning, position teaching, and other setup operations.
SCARA	Selective Compliance Assembly Robot Arm
T20 Pendant	Optional, handheld device used to manually jog the robot, teach locations, and debug programs without a PC. This is also referred to as a Teach Pendant or a pendant.
Quill	Mechanical robot component that provides motion in the z-axis and rotary motion for the tool flange. This is a ball-screw mechanism.
Work Envelope	Working area that is accessible by the robot considering any end-of-arm tooling and part shapes that are attached.
Workspace	Total area that the robot occupies considering all capable range of motion.

# Revision History

---

A manual revision code appears as a suffix to the catalog number on the front and back covers of the manual.

**Cat. No. I658-E-09**

↑  
Revision code

Revision code	Date	Revised content
09	August 2025	EtherCAT SubDevice functionality, updates and minor modifications
08	March 2024	Updates and minor modifications
07	June 2023	Updates and minor modifications
06	April 2022	Updates and minor modifications
05	January 2022	Updates and minor modifications
04	February 2021	Minor modifications
03	January 2021	Corrections and revisions
02	December 2020	Minor modifications
01	November 2020	Original production

# 1

## Overview

This section provides general information about the robot.

---

<b>1-1</b>	<b>Intended Use</b> .....	<b>1-2</b>
<b>1-2</b>	<b>Robot Features</b> .....	<b>1-3</b>
1-2-1	Robot System .....	1-3
1-2-2	Basic Robot Components.....	1-4
1-2-3	Front Panel.....	1-7
1-2-4	Connectors and Ports.....	1-8
<b>1-3</b>	<b>Information Labels</b> .....	<b>1-11</b>
1-3-1	Robot Label .....	1-11
1-3-2	Controller Label .....	1-12
<b>1-4</b>	<b>Robot Configurations</b> .....	<b>1-13</b>
1-4-1	i4-350L .....	1-13
1-4-2	i4-450L .....	1-13
1-4-3	i4-550L .....	1-13
1-4-4	i4-550L (350 mm Z).....	1-14
1-4-5	Mounting and Cabling Options .....	1-14
<b>1-5</b>	<b>Model Numbers</b> .....	<b>1-15</b>
1-5-1	Robot Model Numbers .....	1-15
1-5-2	Controller Model Numbers .....	1-15
<b>1-6</b>	<b>Optional Hardware</b> .....	<b>1-16</b>
1-6-1	IO Blox.....	1-16
1-6-2	T20 Pendant.....	1-16
1-6-3	IPC Application Controller .....	1-17
1-6-4	XIO Termination Block.....	1-17
1-6-5	Optional Cables.....	1-19
1-6-6	Camera Mounting Kit.....	1-20
1-6-7	Bellows Kit.....	1-21
1-6-8	Pneumatic Valve Kit .....	1-22
1-6-9	Power Supply Kits .....	1-23

# 1-1 Intended Use

The i4L robot is a selective compliance assembly robot arm (SCARA) for use within factory environments. It is designed to perform automated motion control typically used with material handling operations.

The i4L robot is capable of high speed, high-precision motion for payloads up to 5 kg. Its compact design and flexible programmability make it ideal for a wide variety of robotic applications.

## DANGER

i4L robots are not collaborative robots. They require a dedicated work area that will prevent personnel from coming into contact with them during operation.

The normal and intended use of these robots does not create hazards.

These robots have been designed and constructed in accordance with the relevant requirements of IEC 60204-1.

These robots are intended for use in parts assembly and material handling for payloads up to 5.0 kg.

Refer to the *Robot Safety Guide (Cat. No. I590)* for details on the intended use of our robots.

These robots are intended for industrial use only.

Perform a risk assessment before using.

These robots are not intended for:

- Use in the presence of ionizing or non-ionizing radiation.
- Use in potentially explosive atmospheres.
- Use in medical or life saving applications.
- Use in a residential setting.



## 1-2 Robot Features

This section provides information about the hardware features of the i4L robot.

- The robot can be mounted on a horizontal surface (table mount) or a vertical surface (wall mount) without the need for additional adapters or brackets.
- Built-in EtherCAT and PROFINET Fieldbus communications.
- Cable connections can be arranged so that they exit through the mounting surface or parallel to the mounting surface.
- A highly visible, multi-colored LED light dome provides convenient indication of the robot status.
- The multi-colored LED light dome has an integrated brake release button built-in.
- A small and compact form factor is achieved with advanced internal controls and circuitry.
- Mounting points are available on the exterior of the robot for items such as cameras and solenoid valves.
- Pass through electrical and pneumatic ports are available from the base of the robot to the outer link.
- The Primary Interface Panel provides a central location for all cable connections and a Secondary Interface Panel on the outer link provides connections for end-of-arm tooling and other hardware.
- Built-in, optically isolated I/O provides 17 inputs and 12 outputs. I/O is expandable with optional I/O Blox units.
- Work envelope limits can be adjusted with configurable hard-stop points for robot joints 1, 2, and 3.

### 1-2-1 Robot System

The robot system provides functionality for conveyor tracking, vision-guided motion, and typical pick-and-place applications. Devices such as encoders, safety equipment, and digital I/O can be connected directly to the robot. An optional Application Controller can be integrated into the system. PROFINET or EtherCAT device functionality can be enabled to exchange data with a PROFINET or EtherCAT controller.

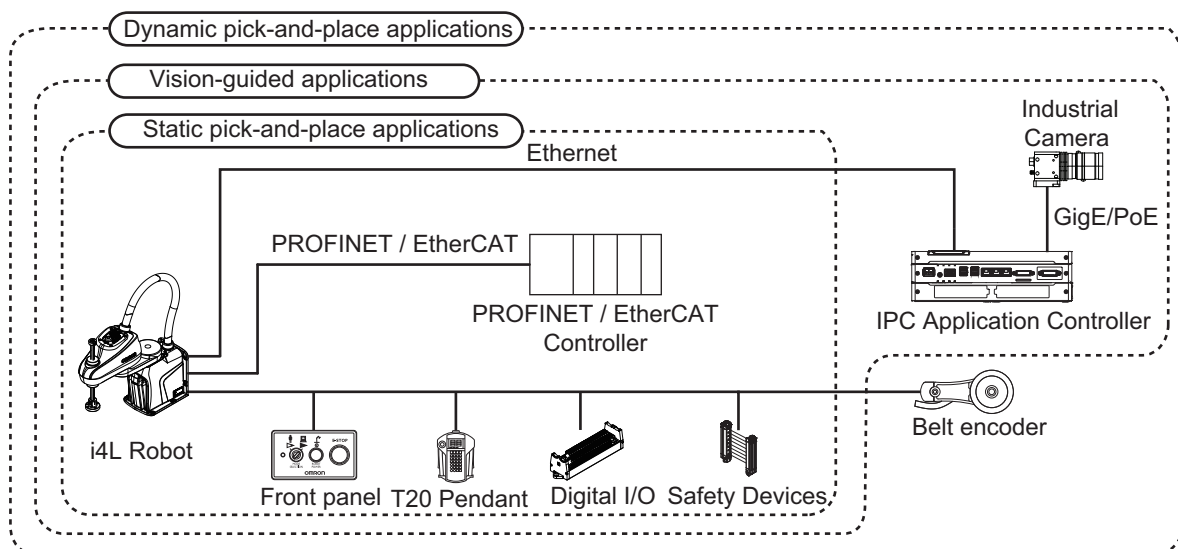

## PROFINET Communications

When PROFINET communications are enabled, the robot can be configured to exchange data with a PROFINET controller. The robot will function as a single-port PROFINET device using the IN/1 connector on the Primary Interface Panel.



### Additional Information

Refer to the following manuals for more information about configuring the robot for PROFINET data exchange.

- *Automation Control Environment (ACE) Version 4 User's Manual (Cat. No. I633)*
- *Industrial Robot Fieldbus Configuration User's Guide (Cat. No. M130)*

## EtherCAT Communications

When EtherCAT communications are enabled, the robot can be configured to exchange data with an EtherCAT MainDevice.

There are two primary communication mechanisms through which data is exchanged between the EtherCAT MainDevice and SubDevice(s): Process Data Objects (PDOs) and Service Data Objects (SDOs).

PDO communication is a cyclic communication method in which high priority information essential for continuous control and monitoring is exchanged in a fixed cycle between the MainDevice and the SubDevices. The fixed cycle is called a PDO communication cycle. The MainDevice can exchange information with SubDevices in realtime in the PDO communication cycle.

SDO communication facilitates acyclic, on-demand, non-critical data exchange between the MainDevice and the SubDevices. SDO communication is primarily used for configuring devices, reading specific parameters, and performing diagnostics.



### Additional Information

Refer to the following manuals for more information about configuring the robot for EtherCAT data exchange.

- *Automation Control Environment (ACE) Version 4 User's Manual (Cat. No. I633)*
- *Industrial Robot Fieldbus Configuration User's Guide (Cat. No. M130)*

## 1-2-2 Basic Robot Components

The robot consists of the following components that are referred to throughout this manual. Use the information below to identify the robot's basic components.

### Mechanical Components

Use the image below to identify the robot's mechanical components.

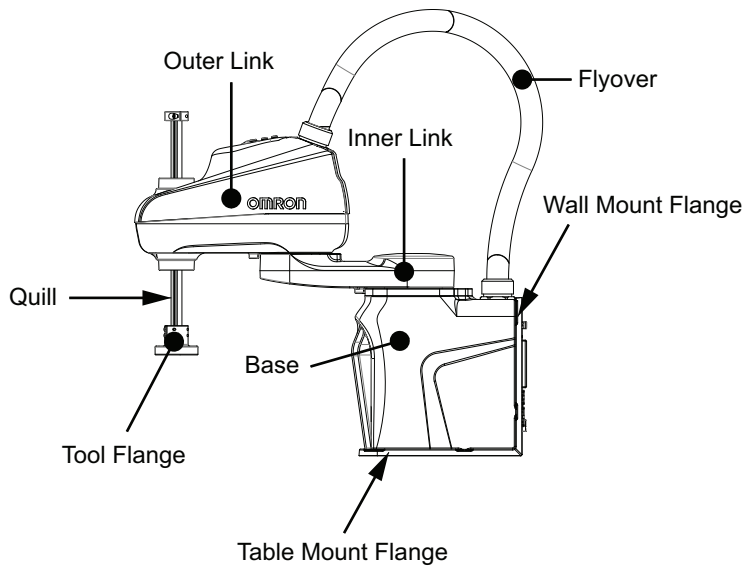

## Axes of Motion

Use the following diagrams to understand the robot's 4 axes of motion.

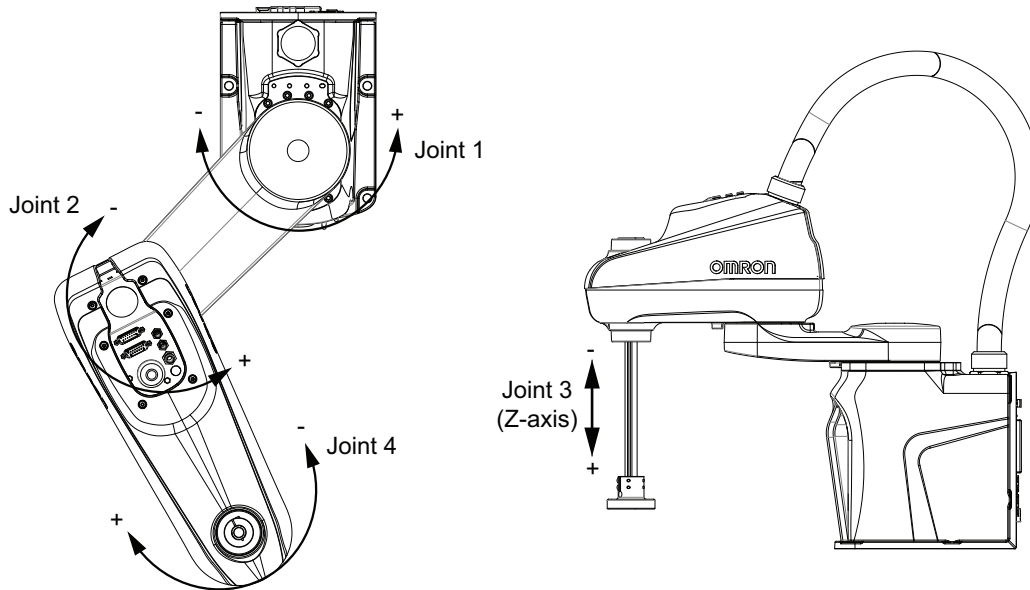

## Interface Panels

Use the information below to identify the robot's interface panels and their functions.

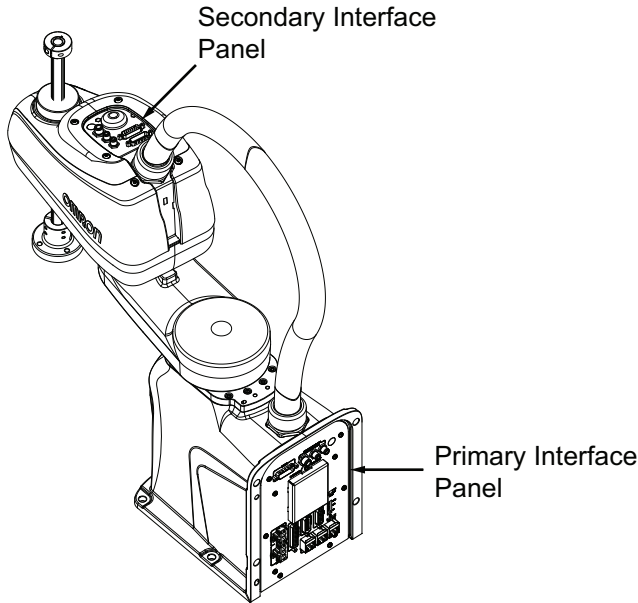

● **Primary Interface Panel**

The Primary Interface Panel is located on the base of the robot and provides access to the following items.

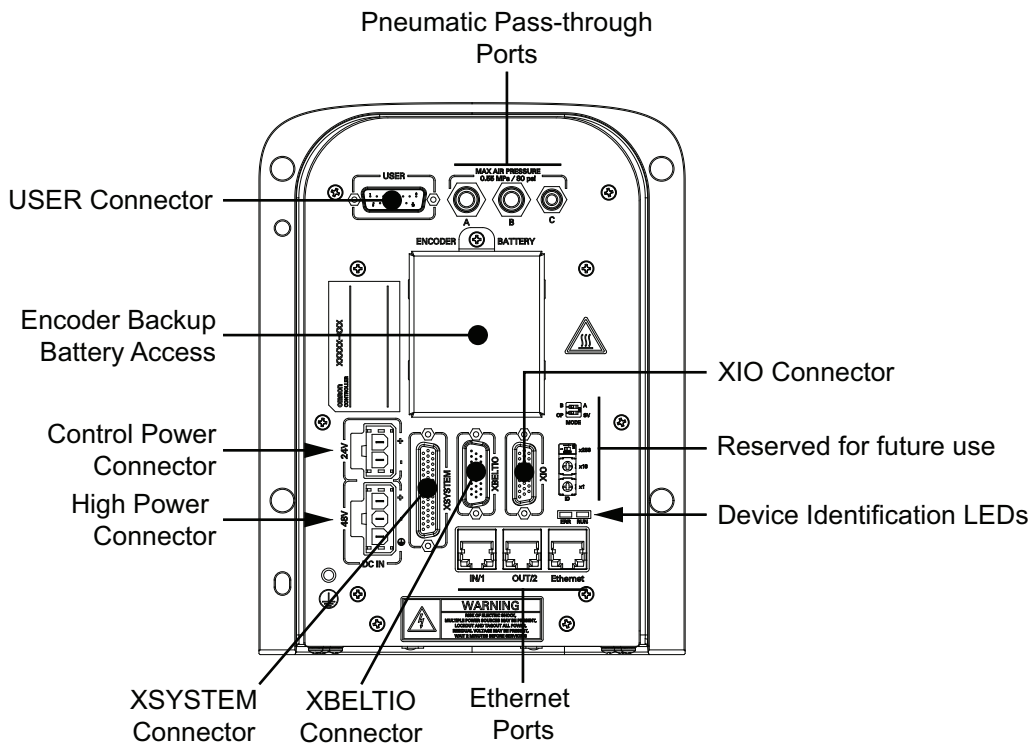

● **Secondary Interface Panel**

The Secondary Interface Panel is located on top of the outer link and provides access to the following items.

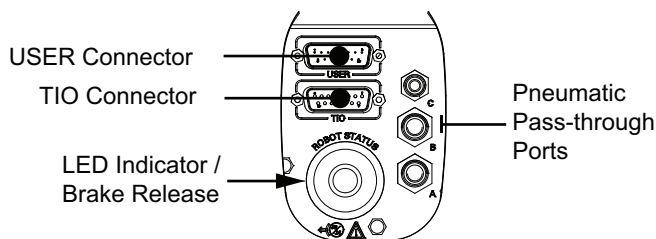

### 1-2-3 Front Panel

The Front Panel is a device that provides remote control and status functions when mounted a safe distance outside of the robot workspace.

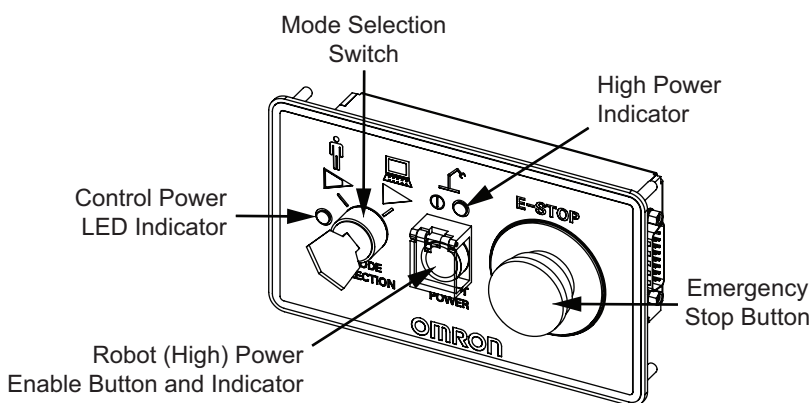

The Front Panel provides the following functions.

- Setting the robot mode to Manual or Automatic mode. Refer to *4-3 Robot Control Modes* on page 4-5 for more information.
- Indicating the robot High Power and Control Power state.
- Enabling robot High Power. Refer to *4-4-1 Robot High Power Operations* on page 4-7 for more information.
- Activating an emergency stop and disabling robot High Power.

The Front Panel is supplied with an extension cable that must be used to connect it to the XFP connector on the XSYSTEM cable.

Design of the factory-supplied Front Panel E-STOP button is in accordance with the requirements of IEC 60204-1 and ISO 13849. The E-STOP button is a dual-channel, passive emergency stop device that supports Category 3 CE safety requirements.

## WARNING

- If you supply your own Front Panel, its design must comply with the requirements of IEC 60204-1 and ISO 13849. The emergency stop's push button must comply with ISO 13850 (Clause 5.5.2).
- Whenever possible, perform Manual mode operations with all personnel outside the workspace.
- If an operator is going to be in the work cell with the switch in Manual mode, the operator must carry an enabling device such as the T20 pendant.
- Disabling the High Power button violates IEC 60204-1. Do not alter its functionality.
- In Automatic mode, the robot can move unexpectedly. Ensure all personnel remain clear of the cell when Automatic mode is enabled.



**Precautions for Safe Use**

If the supplied Front Panel is not used, a High Power indicator light must be present in the system. This indicator light must be amber in color. It must be either mounted to the robot or integrated into the work cell where it is visible from all approaches or entry points.

**Precautions for Correct Use**

Either a Front Panel or equivalent circuits are required to enable High Power to the robot. Refer to *XFP Wiring Diagram* on page 3-41 for more information.

**1-2-4 Connectors and Ports**

This section describes all connectors and ports on the robot.

**USER Connectors**

The USER connectors provide pass-through electrical signals from the Primary Interface Panel to the Secondary Interface Panel.

Pass-through electrical signals are typically used for end-of-arm tooling sensing and control.

All USER connector pin associations between the Primary Interface Panel and the Secondary Interface Panel are one-to-one. For example, pins 1 through pins 15 of the USER connector on the Primary Interface Panel are directly connected to pins 1 through 15 of the USER connector on the Secondary Interface Panel.

There are no twisted-pair conductors between the USER connectors on the Primary Interface Panel and the Secondary Interface Panel. Data communication is not recommended for these connectors.

**! WARNING**

All signals that pass-through the USER connectors are not associated with any robot controls, emergency stop circuits, or robot power. Implement appropriate safety measures to ensure these signals are not active during emergency stop conditions or while the robot is powered OFF.

**Control Power Connector**

The Control Power connector is used to supply 24 VDC to the robot logic circuits. When power is supplied to this connector, the robot will boot up and control functions such as programming and configuration are possible.

A mating connector is supplied with the robot. Control power is user-supplied.

**Precautions for Correct Use**

Robot motion is not possible until High Power is supplied and has been enabled.

**High Power Connector**

The High Power connector is used to supply 48 VDC to the internal servo amplifiers.

When power is supplied to this connector and High Power has been enabled, the robot is ready to move.

A mating connector is supplied with the robot. High Power is user-supplied.



#### Precautions for Correct Use

- Robot motion is not possible until High Power is supplied and has been enabled.
- Control Power must be present before High Power can be enabled.

## XSYSTEM Connector

The XSYSTEM connector provides connections to external equipment such as a Front Panel, Teach Pendant, and user-supplied safety devices.

The robot is supplied with an XSYSTEM cable and jumper plugs. This cable provides connections for a Front Panel, Teach Pendant, and other user-supplied safety devices.

## XBELTIO Connector

The XBELTIO connector provides access to the following signals.

- Belt encoder inputs 1 and 2
- Expansion I/O
- RS-232

## XIO Connector

The XIO connector provides access to built-in I/O of the robot (12 inputs, 8 outputs).

## Ethernet Ports

The Ethernet ports provide communication interfaces for externally connected devices as described in the table below.

If the ports are configured for PROFINET or Ethernet, they are internally connected with an internal network switch that does not support cut-through switching (forwarding).



#### Precautions for Correct Use

Depending on your application, some latency may occur between devices that communicate through the IN/1, OUT/2, and Ethernet ports. Special consideration should be made when connecting devices to these ports that require time-critical operations.

Port Name	Communication Type	Details
IN/1	Ethernet, EtherCAT, PROFINET	Supports standard Ethernet communications, or (when enabled) EtherCAT or PROFINET communications.

Port Name	Communication Type	Details
OUT/2	Ethernet, EtherCAT	Supports standard Ethernet communications, or (when enabled) EtherCAT communications in a line, ring, or branching topology.
Ethernet	Ethernet	Supports standard Ethernet communications typically used for connecting a development PC and Application Controller.



#### Additional Information

- All Ethernet Ports have a common IP address.
- The default IP address of the robot is 192.168.250.100.
- Refer to *Automation Control Environment (ACE) Version 4 User's Manual (Cat. No. I633)* for more information about enabling EtherCAT or PROFINET communications.
- Refer to *Industrial Robot Fieldbus Configuration User's Guide (Cat. No. M130)* for more information about configuring the fieldbus.

## Pneumatic Pass-through Ports

The pneumatic pass-through ports provide pass-through air lines from the Primary Interface Panel to the Secondary Interface Panel.

Pneumatic pass-through ports are typically used for end-of-arm tooling control.

## TIO Connector

The TIO connector provides 5 digital inputs and 4 digital outputs for use with end-of-arm tooling.

These signals are fully programmable for integration with robot motion, part sensing, and other robot functions.

# 1-3 Information Labels

The information labels contain relevant information about the robot and the controller. The following examples will be different from your product label.

## 1-3-1 Robot Label

The robot label is described below.

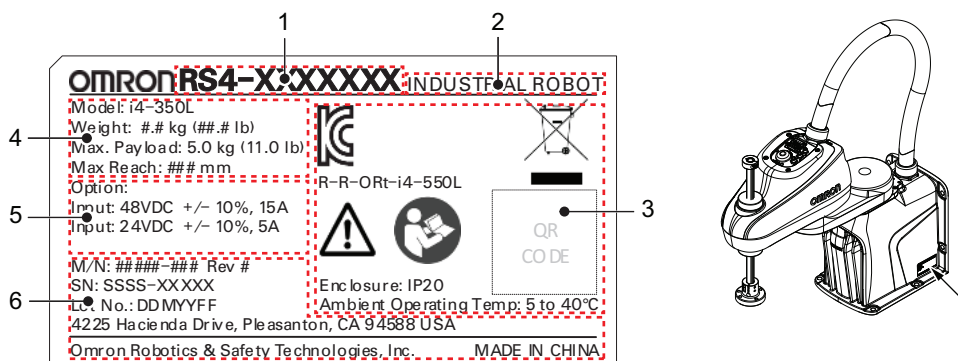

Item	Name	Description
1	Part number *1	The robot part number is displayed.
2	Product type	The product type is displayed.
3	Alerts and compliance	General alerts and compliance information is displayed.
4	Robot information	The robot model, weight, maximum payload, and maximum reach is displayed.
5	Electrical information	General electrical power supply information about the robot is displayed.
6	Production information	The following information is provided. <ul style="list-style-type: none"> <li>• M/N indicates the model number and revision level.</li> <li>• SN indicates the serial number.</li> <li>• Lot. No. indicates the lot number in the format of DDMYYFF. Month number 1 to 9 for January to September, X for October, Y for November, and Z for December. FF is reserved for internal use.</li> <li>• Product origin information is displayed.</li> </ul>

\*1. Refer to *1-5 Model Numbers* on page 1-15 for model information.

## 1-3-2 Controller Label

The controller label is described below.

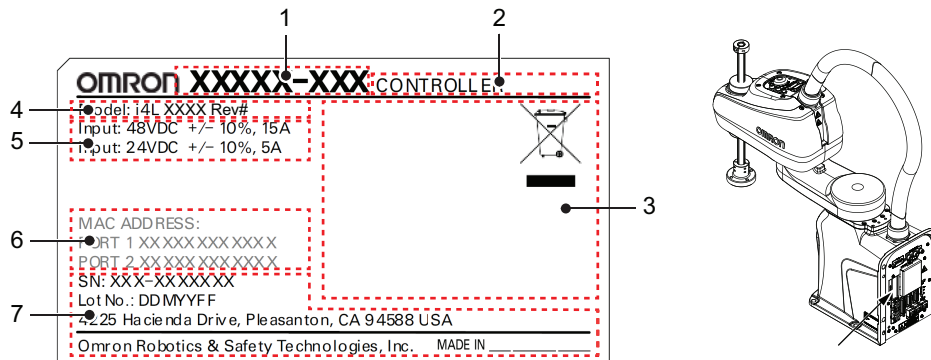

Item	Name	Description
1	Part number *1	Controller part number.
2	Product type	Product type.
3	Alerts and compliance	General alerts and compliance information.
4	Controller information	Controller model and version.
5	Electrical information.	Controller electrical requirements.
6	MAC Address	MAC address for the robot controller.
7	Production information	The following information is provided. <ul style="list-style-type: none"> <li>• SN indicates the serial number.</li> <li>• Lot. No. indicates the lot number in the format of DDMYYFF. Month number 1 to 9 for January to September, X for October, Y for November, and Z for December. FF is reserved for internal use.</li> <li>• Product origin information.</li> </ul>

\*1. Refer to 1-5 Model Numbers on page 1-15 for model information.

## 1-4 Robot Configurations

The i4L robot is offered in a variety of configurations with different work envelopes and z-axis stroke lengths.

### 1-4-1 i4-350L

The i4-350L configuration has a reach of 350 mm and a z-axis stroke of 180 mm.

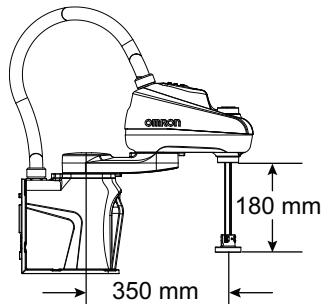

### 1-4-2 i4-450L

The i4-450L configuration has a reach of 450 mm and a z-axis stroke of 180 mm.

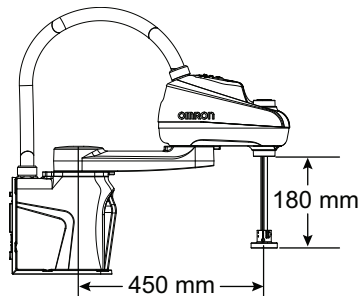

### 1-4-3 i4-550L

The i4-550L configuration has a reach of 550 mm and a z-axis stroke of 180 mm.

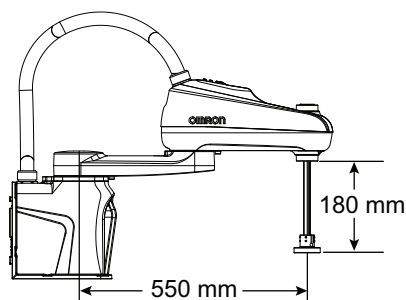

### 1-4-4 i4-550L (350 mm Z)

The i4-550L (350 mm Z) configuration has a reach of 550 mm and a z-axis stroke of 350 mm.

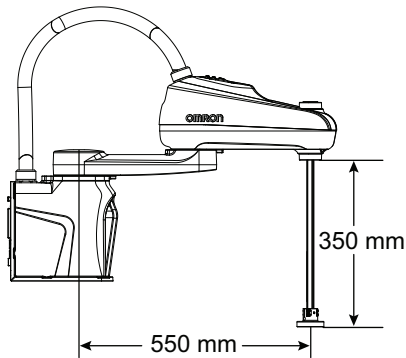

### 1-4-5 Mounting and Cabling Options

The robot has a table mount flange and a wall mount flange integrated into the base. This allows the robot to be table-mounted or wall-mounted without the need for additional brackets or adapters. The rear / bottom Primary Interface Panel orientation options allow cables to exit through the mounting surface or parallel to the mounting surface as shown below.

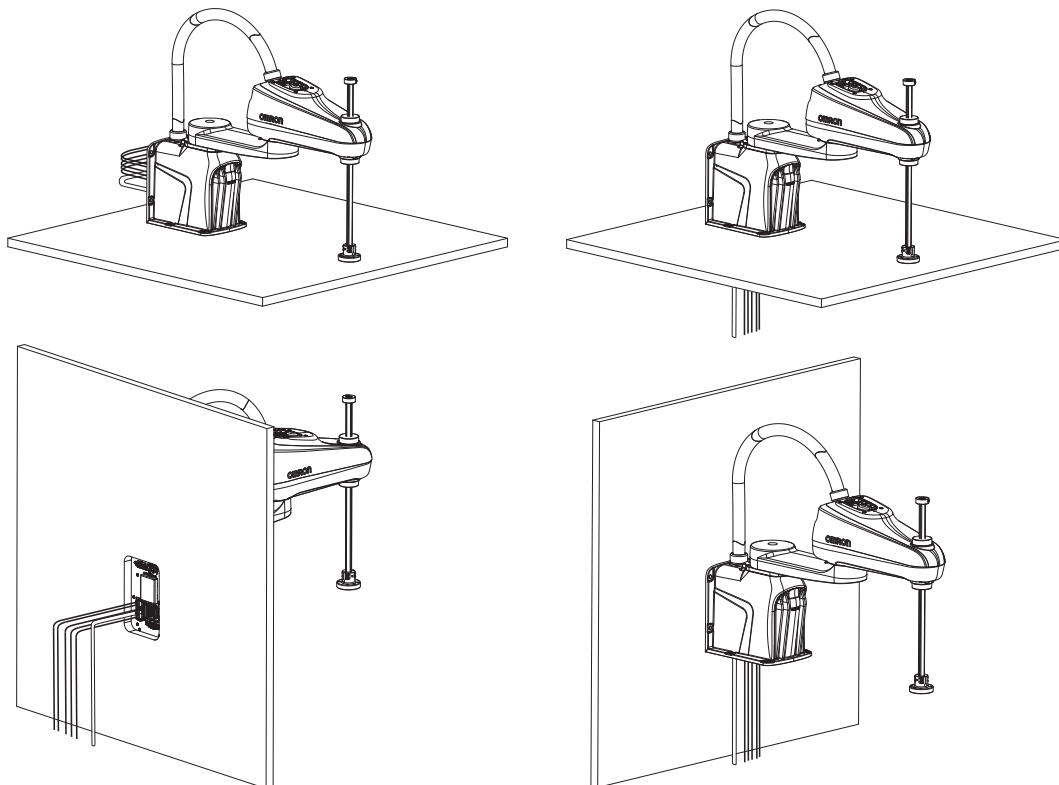

## 1-5 Model Numbers

Models numbers and descriptions associated with the robot are provided below.

### 1-5-1 Robot Model Numbers

The table below provides all robot model numbers and descriptions.

Model Number	Reach	Z-axis Stroke	Primary Interface Panel Orientation
RS4-2053002	350 mm	180 mm	Rear
RS4-2054002	450 mm		
RS4-2055002	550 mm		
RS4-2055004	550 mm	350 mm	
RS4-2053102	350 mm	180 mm	Bottom
RS4-2054102	450 mm		
RS4-2055102	550 mm		
RS4-2055104	550 mm	350 mm	

### 1-5-2 Controller Model Numbers

The table below provides all robot controller model numbers and descriptions.

Model Number	Description
i4L-iCS	Internal controller for the robot.

## 1-6 Optional Hardware

The following optional hardware is available for the robot.

### 1-6-1 IO Blox

IO Blox units are available to expand the I/O capacity of the robot. Each unit offers 8 inputs and 8 outputs. Up to 4 IO Blox units can be added to the robot.

- The part number for an IO Blox unit connected to the robot is 90356-30200.
- The part number for IO Blox units connected to another IO Blox unit is 90356-30100.



#### Additional Information

Refer to the following areas for more information.

- 3-7-3 *IO Blox Connections* on page 3-35
- *Omron Adept IO Blox User's Guide (04638-000)*

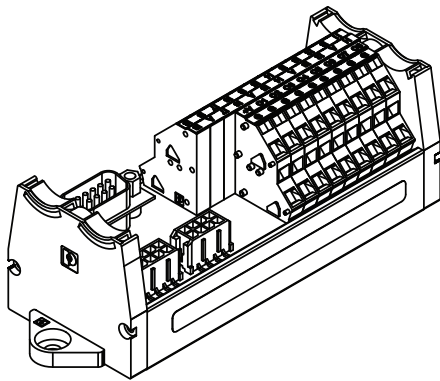

### 1-6-2 T20 Pendant

The T20 pendant is an optional handheld device that allows you to manually jog the robot, teach locations, and view V+ programs without a PC.

- The part number for the pendant kit is 10046-010. This kit includes the T20 pendant, an adapter cable (3 m), and a jumper plug.
- The adapter cable includes a round, 17-pin connector that can be panel-mounted. It can be mounted to a surface with up to 6.5 mm of thickness and requires an M23 hole.



#### Precautions for Correct Use

The T20 pendant can only control the robot it is directly connected to.



#### Additional Information

Refer to the *T20 Pendant User's Manual (Cat. No. I601)* for more information.

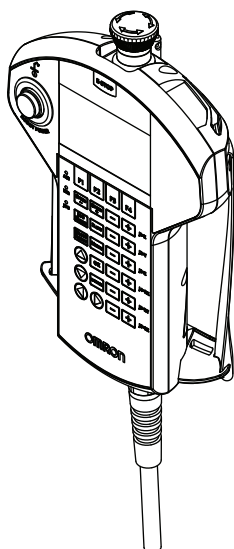

### 1-6-3 IPC Application Controller

The IPC Application Controller can be added to your system to execute PackManager and Robot Vision Manager applications.

The Pack Manager application controls automated pick-and-place systems with cameras, conveyors, and robots based on the data that you set up in the ACE Software. It is executed on the IPC Application Controller to control the process data and recipe data.

The Robot Vision Manager application processes images captured by cameras based on the data that you set up in the ACE Software. It is executed on the IPC Application Controller.



#### Additional Information

Refer to the following areas for more information.

- *Automated Control Environment (ACE) Version 4 User's Manual (Cat. No. I633)*
- *IPC Application Controller User's Manual (Cat. No. I632)*

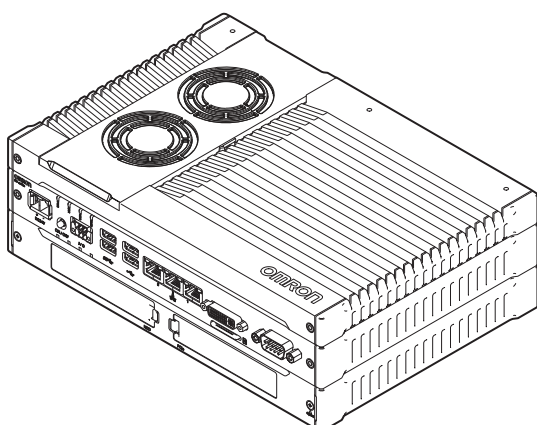

### 1-6-4 XIO Termination Block

The XIO Termination Block is used to connect digital I/O devices to the robot. This unit provides terminal block connection points for 12 inputs and 8 outputs. LED indicators are provided to indicate

ON/OFF status. Each input has a switch to simulate input signals for troubleshooting or testing purposes.

Use the XIO cable to connect the XIO Termination block to the robot.

The part number for the XIO Termination Block is 90356-40100 (2 m cable included).



### **Additional Information**

---

Refer to the *Adept XIO Termination Block Installation Guide (00340-000)* for more information.

---

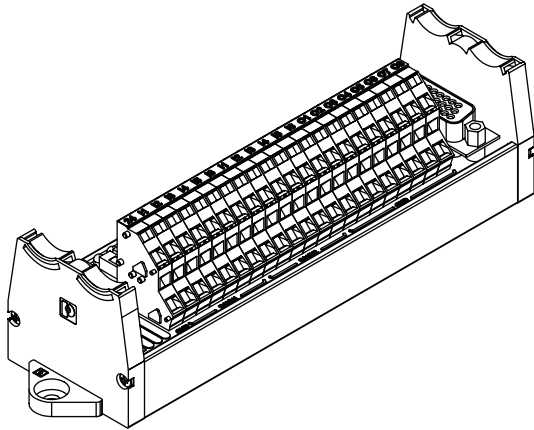

## 1-6-5 Optional Cables

This section provides information about optional cables that are available.

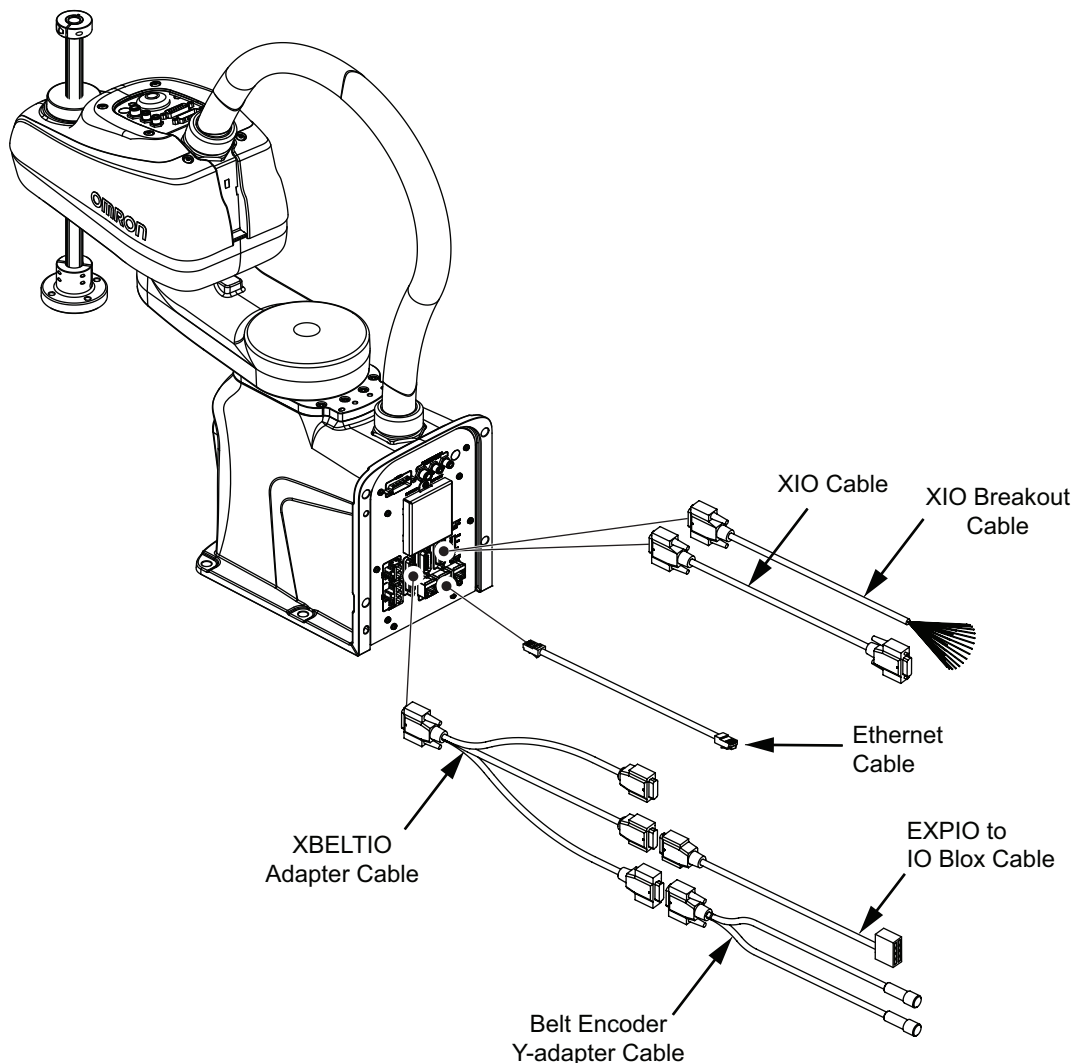

### XBELTIO Adapter Cable

The optional XBELTIO adapter cable connects to the XBELTIO connector on the Primary Interface Panel. It provides connections for belt encoder, RS-232, and IO Blox signals.

- The part number for this cable is 13463-000.
- The length of this cable is 600 mm.

### Belt Encoder Y-adapter Cable

The optional belt encoder Y-adapter cable connects to the XBELTIO adapter cable's BELT ENCODER connector. This cable provides individual connections for two belt encoder input signals.

- The part number for this cable is 09443-000.
- The length of this cable is 3 m.

## XIO Breakout Cable

The optional XIO breakout cable connects to the XIO connector on the Primary Interface Panel and provides a method to connect I/O devices directly to the robot without using an XIO Termination Block unit.

- This cable is not compatible with the XIO Termination Block.
- This cable cannot be used together with an XIO cable.
- The part number for this cable is 04465-000.
- The length of this cable is 5 m.

## XIO Cable

The optional XIO cable connects to the XIO connector on the Primary Interface Panel. It is used to connect an XIO Termination Block to the system.

- This cable cannot be used together with the XIO Breakout cable.
- The part number for this cable is 03695-000.
- The length of this cable is 2 m.

## EXPIO to IO Blox Cable

The optional EXPIO to IO Blox cable connects to the XBELTIO adapter cable's FORCE/EXPIO connector. It allows a direct connection between this connector and optional IO Blox units.

- The part number for this cable is 04677-030.
- The length of this cable is 3 m.



### Additional Information

Refer to the *Omron Adept IO Blox User's Guide (04638-000)* for more information.

## 1-6-6 Camera Mounting Kit

A camera mounting bracket can be used to attach a Basler or Sentech camera to the robot outer link. This is fastened to the bottom of the outer link, near the z-axis quill exit.

The part number of the camera mounting bracket kit is 22871-000. This kit includes all hardware and fasteners to attach a Basler or Sentech camera to the robot outer link as shown below.

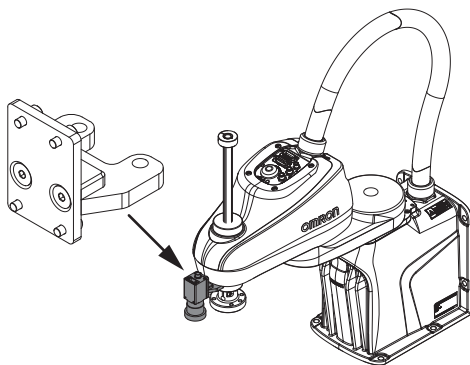

Apply Loctite 222 or equivalent thread locking compound to all screws. Apply the following torque values when tightening the screws.

- 51120-67010: 2.9 N-m
- 04221001184-0006: 1.3 N-m
- 51006-69012: 5.7 N-m

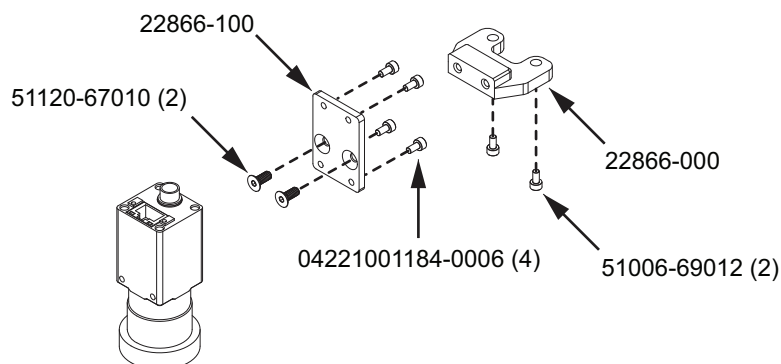

The following items are included in the camera mounting bracket kit for cable management.

- 23681-000 (2)
- 27300-00024 (4)

Item 23681-000 can be installed for cable management. Remove the outer link cover, drill 0.25 inch holes in the locations shown below, and then insert the cable tie mounts. Refer to *3-4-4 Pneumatic Valve Kit Installation Procedure* on page 3-16 for more information about outer link cover removal and replacement.

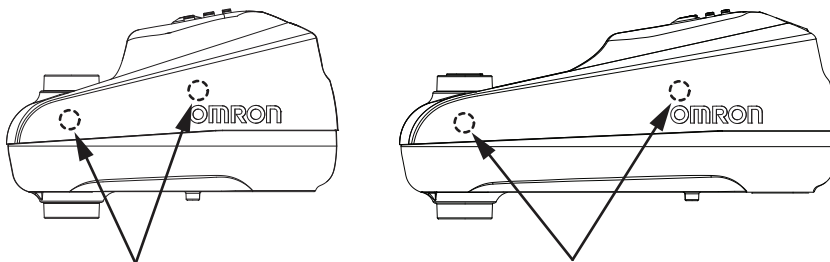

## 1-6-7 Bellows Kit

Bellows are an optional item that can be placed on upper and lower exposed portions of the Joint 3 quill for additional environmental protection. Bellows prevent debris or liquid from entering the internal compartment of the outer link, protect the Joint 3 quill, and prevent contamination of items external to the robot.

A hole is present at the top of the bellows assembly that can be used for a user-supplied seal fitting if cabling or tubing needs to pass through the Joint 3 quill.

The part number for bellows kits are provided below. All components are supplied for installation.

- Bellows Kit (180 mm quill): 22839-000
- Bellows Kit (350 mm quill): 22868-000

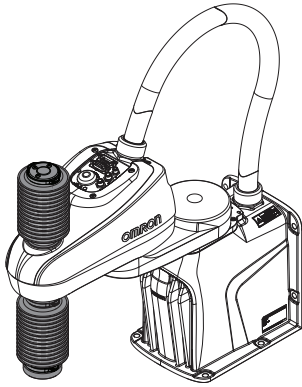

### Precautions for Correct Use

The z-axis stroke is reduced when bellows are present. Bellows reduce the travel by 27 mm (180 mm quill length) / 53 mm (350 mm quill length) in the z-axis retracted position and 27 mm (180 mm quill length) / 53 mm (350 mm quill length) in the z-axis extended position. Always adjust joint motion limits with software settings in the robot configuration area when bellows are installed to restrict range of motion. Refer to the *Automation Control Environment (ACE) Version 4 User's Manual (Cat. No. I633)* for more information.

## 1-6-8 Pneumatic Valve Kit

Three pneumatic valves can be mounted to the outside of the outer link to control devices such as grippers or end-effectors. The valves are connected to the TIO connector on the Secondary Interface Panel and controlled with V+ signals.

The part number of the pneumatic valve kit is 22872-000.

The pneumatic valve kit includes all necessary hardware to mount and electrically connect the valves to the robot.

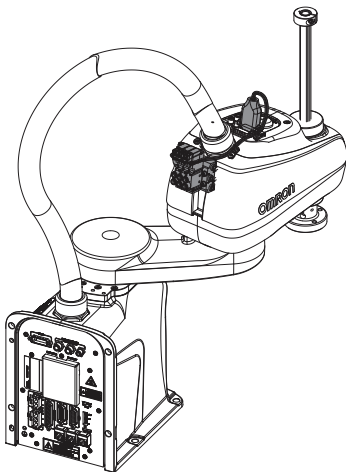

### Additional Information

- When the pneumatic valve kit is installed, TIO signals are allocated for valve solenoid control. Refer to *Pneumatic Valve Kit Signals* on page 3-35 for more information.
- Valve types are SMC type VQZ1121-5MO1-C4-Q.

## 1-6-9 Power Supply Kits

Optional power supply kits are available to provide Control Power and High Power to the robot.

### Control Power Kit

The Control Power Kit provides 24 VDC power to the robot. This kit consists of a power supply and the required DC connector and cable. The connector is pre-installed on the cable.

- The Control Power Kit part number is 23912-000.
- The power supply part number is S8VK-G24024.
- The length of the cable from the power supply to the robot is 5 m.



#### Additional Information

Refer to the *S8VK-G Series Switch Mode Power Supply Datasheet (Cat. No. T056)* for more information.

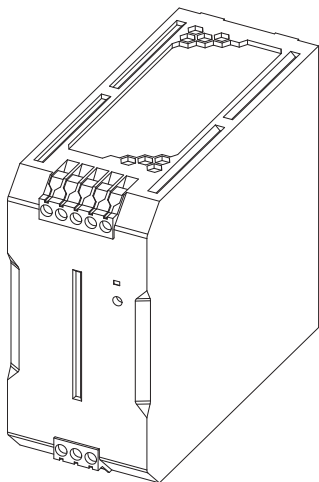

### High Power Kit

The High Power Kit provides 48 VDC power to the robot. This kit contains two 48 VDC power supplies, a redundancy unit, and all required DC cables and connectors. All connectors are pre-installed on the cables.

- The High Power Kit part number is 23913-000.
- The power supply part number is S8VK-G48048.
- The redundancy unit part number is S8VK-R20.
- The length of the cable from the power supply to the robot is 5 m.



#### Additional Information

Refer to the following documents for more information.

- *S8VK-G Series Switch Mode Power Supply Datasheet (Cat. No. T056)*
- *S8VK-R Series Redundancy Unit (Cat. No. T059)*

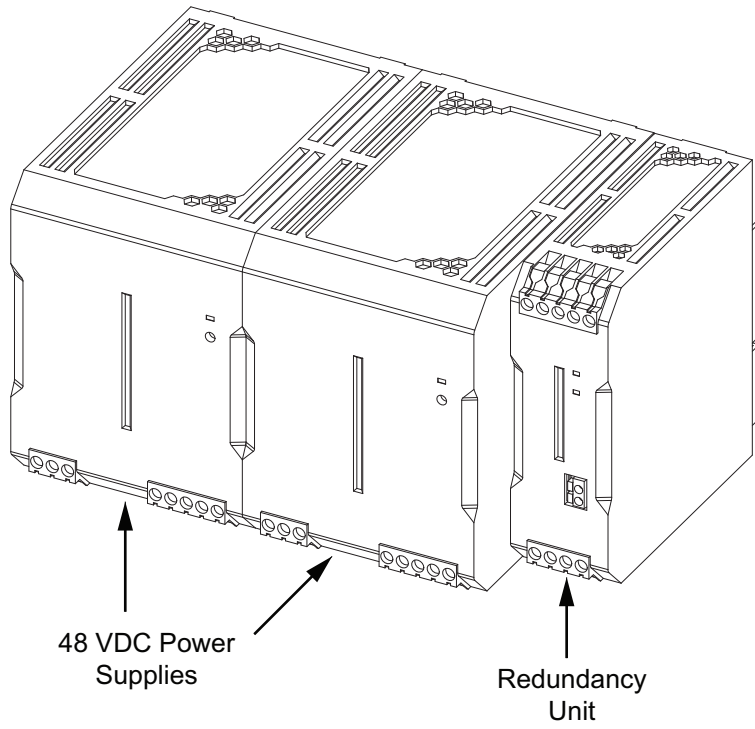

# 2

## Specifications

This section provides specifications for the robot's hardware, performance, electrical connections, installation environment, and other technical aspects of the system.

---

<b>2-1</b>	<b>Physical Specifications .....</b>	<b>2-2</b>
2-1-1	Robot Overall Dimensions.....	2-2
2-1-2	Mounting Flange Dimensions.....	2-4
2-1-3	Tool Flange Dimensions .....	2-5
2-1-4	Front Panel Dimensions .....	2-5
2-1-5	Camera Mounting Bracket Dimensions.....	2-6
2-1-6	Robot Work Envelope Dimensions.....	2-6
2-1-7	Robot Weights .....	2-8
<b>2-2</b>	<b>Performance Specifications .....</b>	<b>2-9</b>
2-2-1	General Performance Information .....	2-9
2-2-2	Stopping Distances and Times.....	2-10
2-2-3	Lateral Push Force .....	2-13
2-2-4	Joint 4 Inertia vs. Acceleration .....	2-13
<b>2-3</b>	<b>Electrical Specifications .....</b>	<b>2-15</b>
2-3-1	Power Supply Specifications .....	2-15
2-3-2	XIO and TIO Connector I/O Specifications.....	2-15
2-3-3	Belt Encoder Specifications.....	2-16
<b>2-4</b>	<b>Environmental Specifications .....</b>	<b>2-17</b>
<b>2-5</b>	<b>Other Specifications .....</b>	<b>2-18</b>
2-5-1	Maximum Kinetic Energy.....	2-18
2-5-2	Ethernet Communication Specifications.....	2-18
2-5-3	EtherCAT Communication Specifications.....	2-18
2-5-4	PROFINET Specifications .....	2-19
2-5-5	Connector and Port Specifications .....	2-19
2-5-6	Mounting Hardware and Torques .....	2-20

## 2-1 Physical Specifications

This section provides physical specifications for the i4L robot.

### 2-1-1 Robot Overall Dimensions

Use the diagrams below to understand the robot's overall physical dimensions.

#### i4-350L Dimensions

Overall dimensions for the i4-350L are provided below.

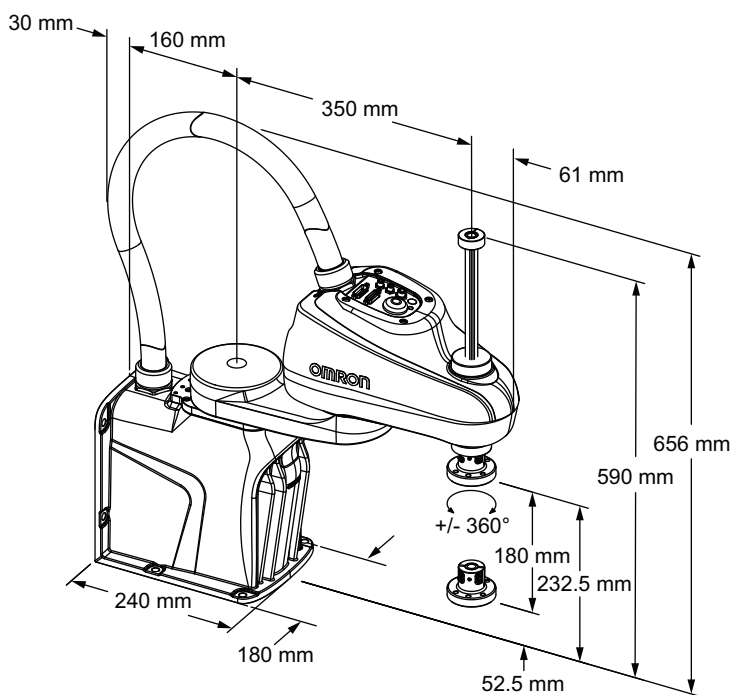

## i4-450L Dimensions

Overall dimensions for the i4-450L are provided below.

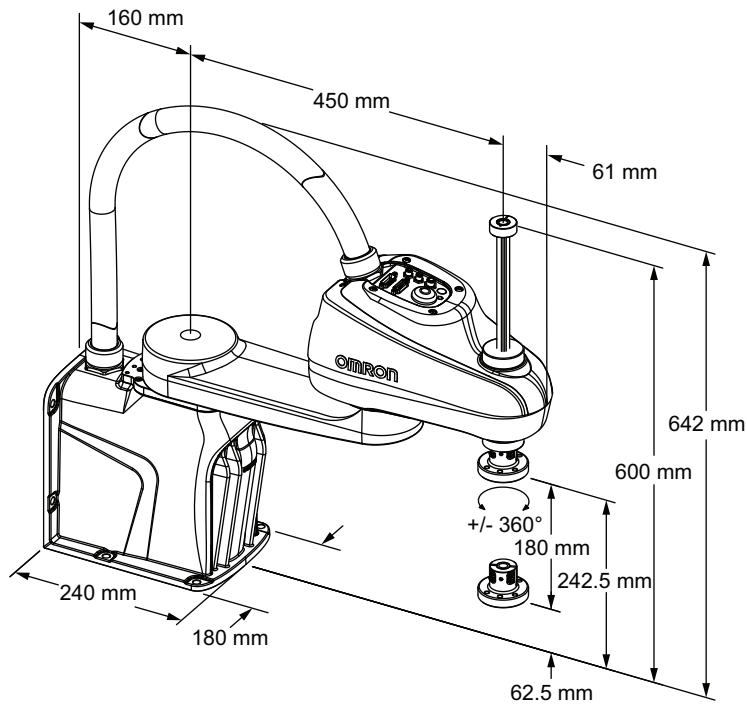

## i4-550L Dimensions

Overall dimensions for the i4-550L are provided below.

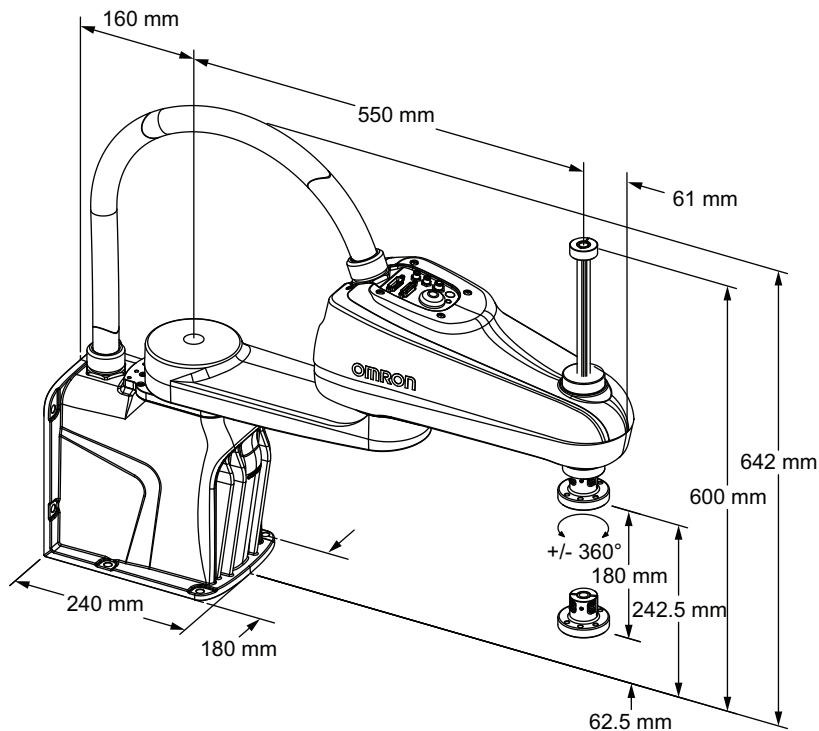

## i4-550L (350 mm Z) Dimensions

Overall dimensions for the i4-550L (350 mm Z) are provided below.

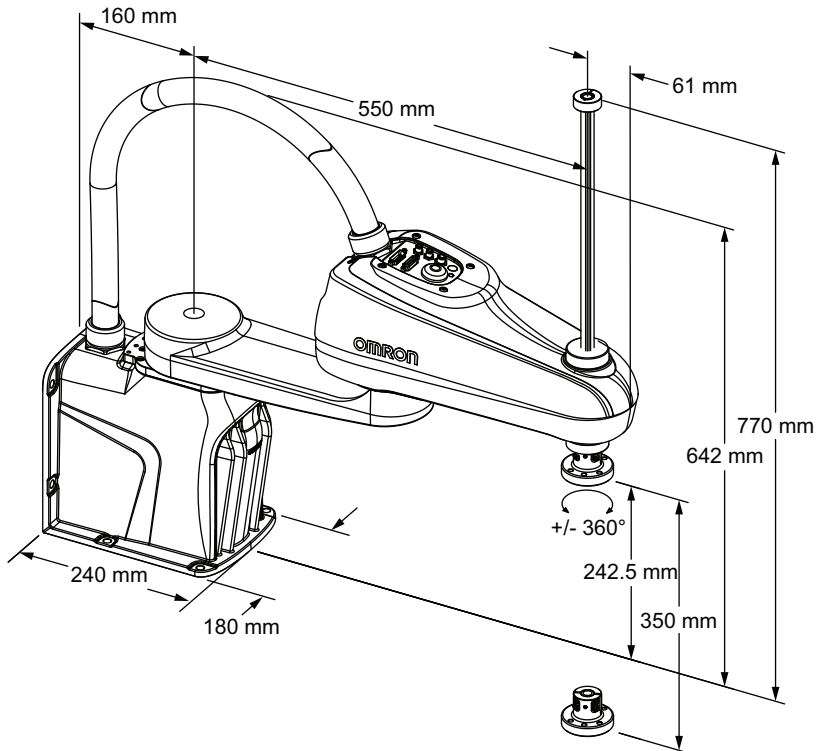

## Cable Clearances

There must be at least 183 mm of clearance from the Primary Interface Panel connectors to provide adequate space for cables. These clearances apply to all robot models.

### 2-1-2 Mounting Flange Dimensions

The robot's mounting flange dimensions are provided below.

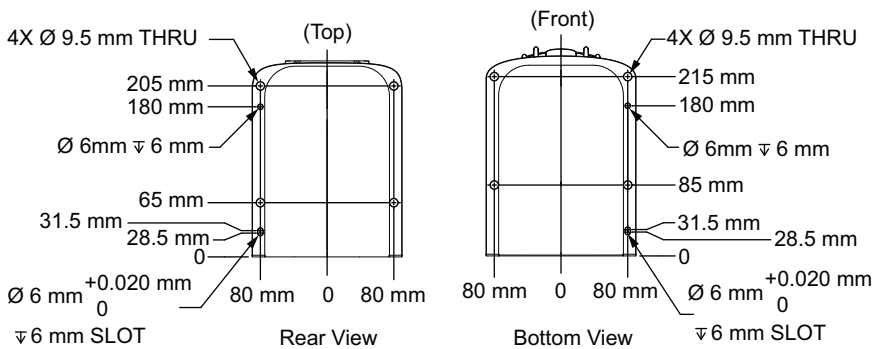

## Cable Exit Cutout Dimensions

Use the cutout dimensions provided below when cables exit the mounting surface.

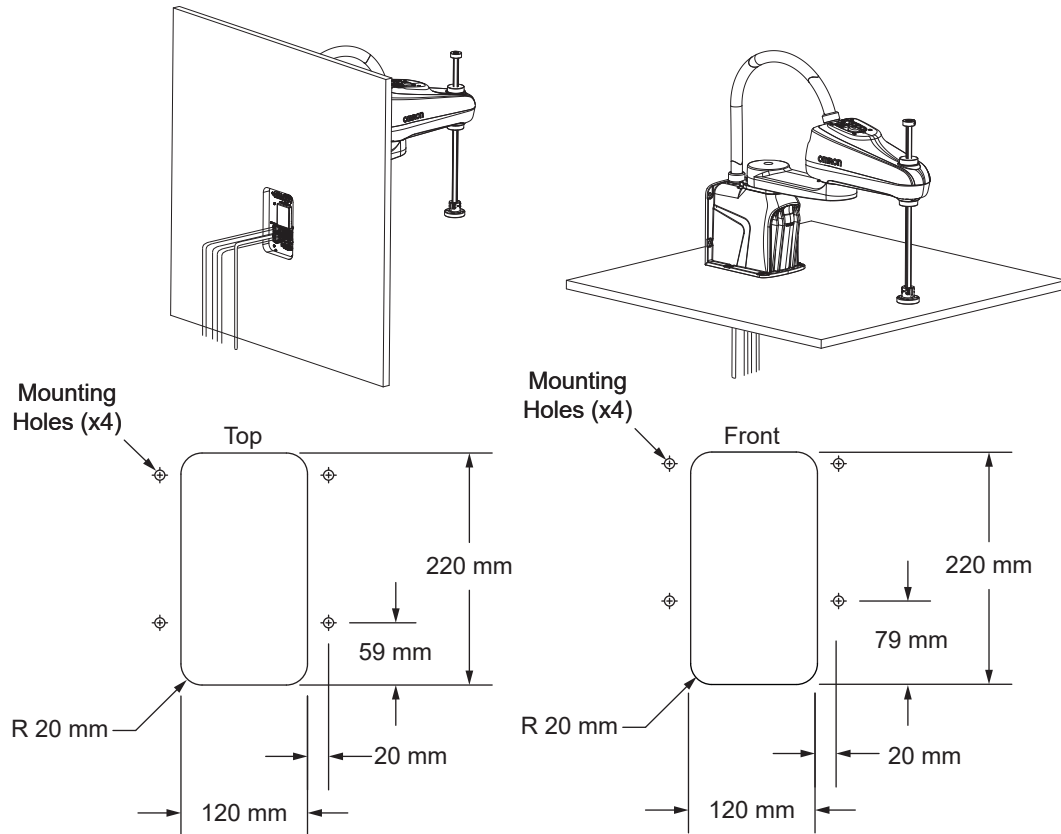

### 2-1-3 Tool Flange Dimensions

The robot's tool flange dimensions are provided below. Geometry and tolerances meet ISO-9409-1-50-4-M6 (2004) requirements for manipulating industrial robots.

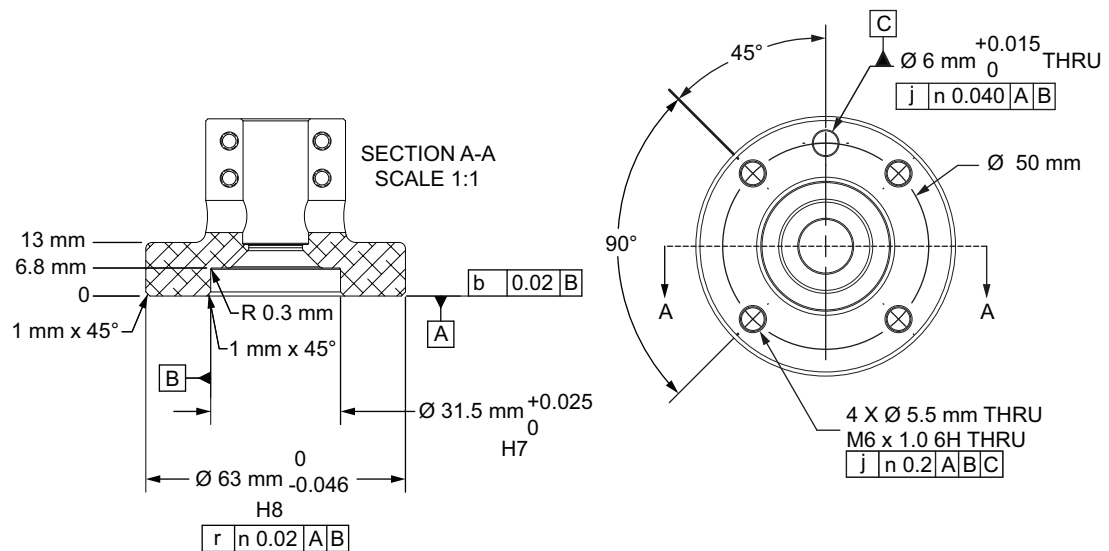

### 2-1-4 Front Panel Dimensions

The Front Panel dimensions are provided below.

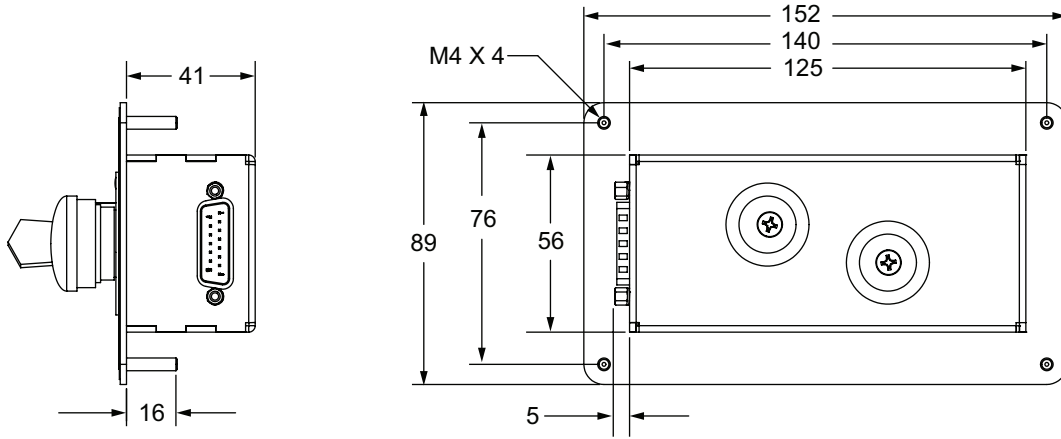

### 2-1-5 Camera Mounting Bracket Dimensions

The camera mounting bracket dimensions are provided below.

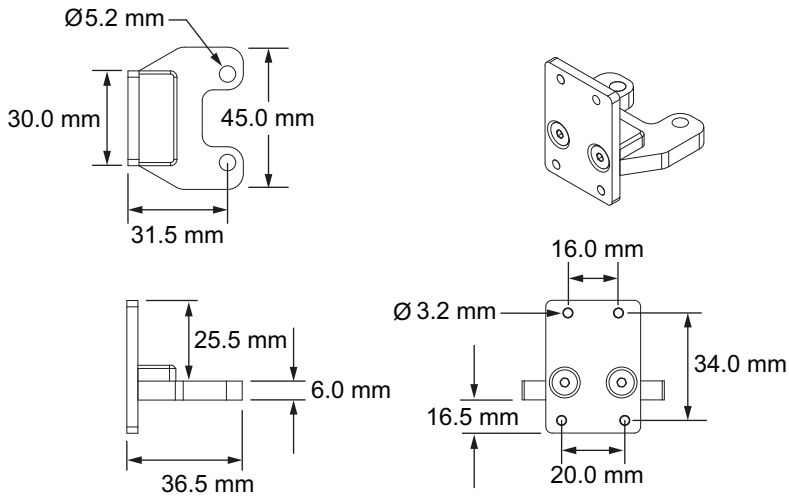

### 2-1-6 Robot Work Envelope Dimensions

Use the diagrams below to understand the robot's working envelope dimensions.

#### i4-350L Work Envelope

Work envelope dimensions are provided below.

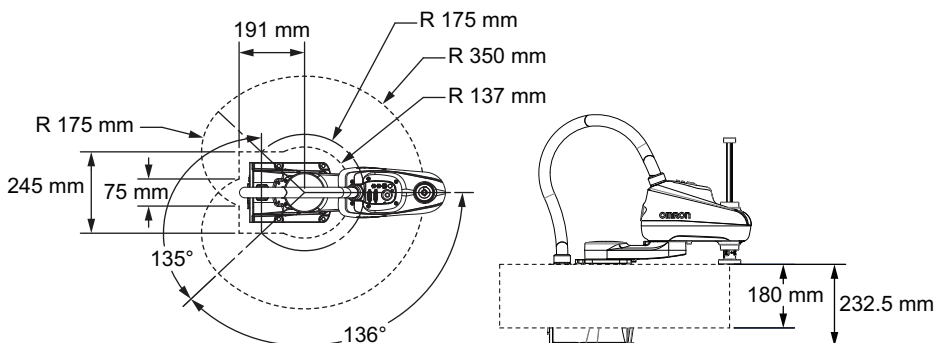

### i4-450L Work Envelope

Work envelope dimensions are provided below.

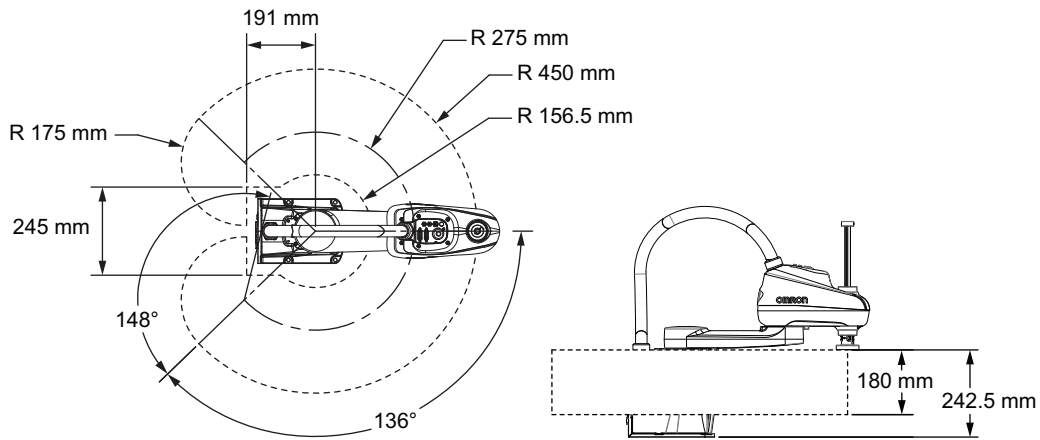

### i4-550L Work Envelope

Work envelope dimensions are provided below.

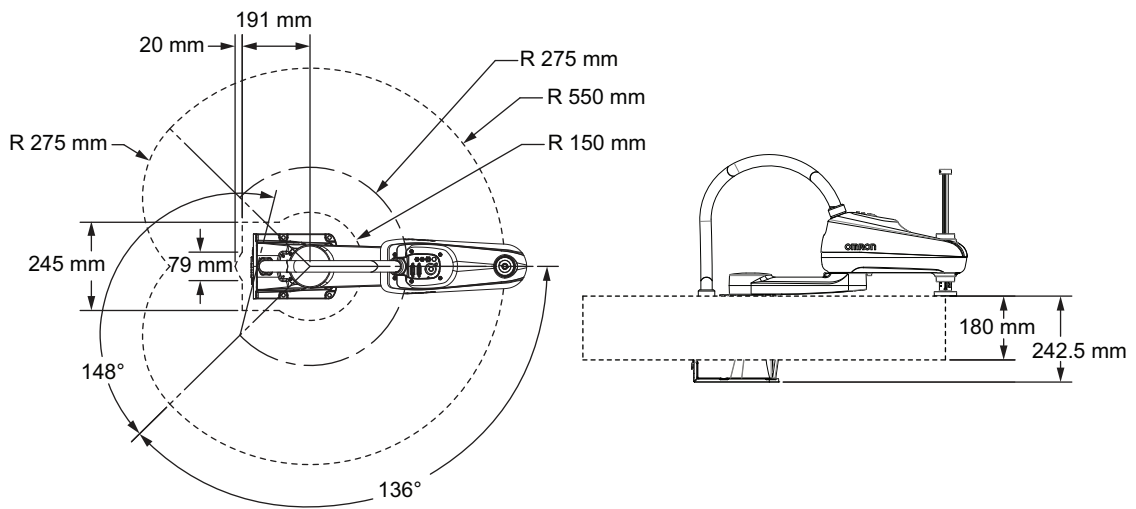

### i4-550L (350 mm Z) Work Envelope

Work envelope dimensions are provided below.

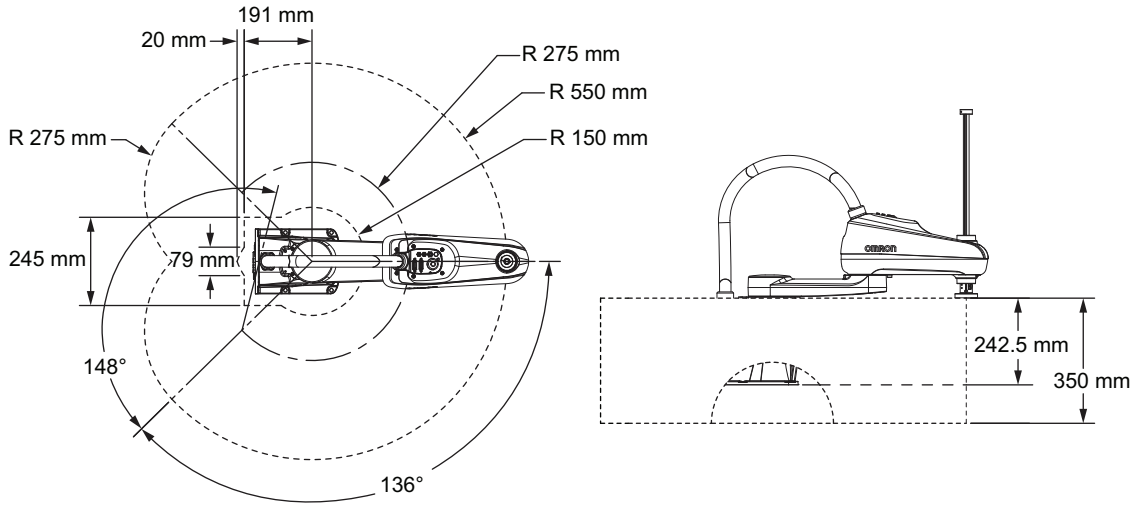

### 2-1-7 Robot Weights

Weights for the different robot models are provided in the following table.



#### Additional Information

Weights provided do not include optional accessories.

Robot Model	Weight
i4-350L	15.1 kg
i4-450L	15.9 kg
i4-550L	16.4 kg
i4-550L (350 mm Z)	16.5 kg

## 2-2 Performance Specifications

The following sections provide robot performance specifications.

### 2-2-1 General Performance Information

The following table provides general performance information for the robot.

Item		i4-350L	i4-450L	i4-550L	i4-550L (350 mm Z)
Payload* <sup>1</sup>		2 kg rated 5 kg maximum			
Reach		350 mm	450 mm	550 mm	
Joint Range	Joint 1	±136°			
	Joint 2	±136°	±148°		
	Joint 3	180 mm			350 mm
	Joint 4	±300,000 rotations			
Joint 4 Moment of Inertia		0.05 kg-m <sup>2</sup> maximum			
Joint 4 Torque Limits* <sup>2*3</sup>		1.1 N-m continuous 5.1 N-m peak* <sup>4</sup>			
Cycle Time* <sup>5</sup>		0.57 s		0.54 s	
Downward Push Force burst with no load* <sup>6</sup>		150 N			
Repeatability at 100% speed		X, Y: 0.01 mm Joint 3: 0.01 mm Joint 4: 0.01°			
Joint speeds (maximum)	Joint 1	456 degrees/s			
	Joint 2	456 degrees/s			
	Joint 3	800 mm/s			
	Joint 4	6000 degrees/s			

- \*1. Payload is considered as any object(s) attached to a robot link or tool flange including items such as end effectors, tooling, valves, grippers, and objects being handled by the robot.
- \*2. Values can be achieved in a 20° C ambient operating environment. Values may decrease in higher ambient temperatures.
- \*3. Refer to 2-2-4 *Joint 4 Inertia vs. Acceleration* on page 2-13 for more detailed information on Joint 4 torque limits.
- \*4. The peak torque can be applied for up to 200 ms with a duty cycle of 10%.
- \*5. Cycle time is defined as a continuous path with straight-line motion cycle in which the robot tool moves up 25 mm, over 305 mm, down 25 mm, and then back along the same path (not achievable over all paths in the robot working envelope). Values listed are for sustained motion, no joint 4 rotation, with a 2 kg payload, at 20° C ambient temperature.
- \*6. The maximum push force can be applied for up to 1 second with a duty cycle of 25%.

### Z-axis Quill Bending Moments

When the robot is operating at high payloads with high acceleration / deceleration, the z-axis quill may be subject to excessive bending moments. Careful considerations must be made under these conditions. Refer to 4-2 *Payload and Acceleration Considerations* on page 4-4 for more information.

## 2-2-2 Stopping Distances and Times

The following graphs present information required by Clause 7.2 n of ISO 10218-1. This information should be used to calculate the safe distance needed when designing and installing safeguarding devices.



WARNING

The stopping time and distance, or angle, of a robot joint from initiation of a stop signal is not negligible and must be taken into account when designing and applying safeguarding devices.

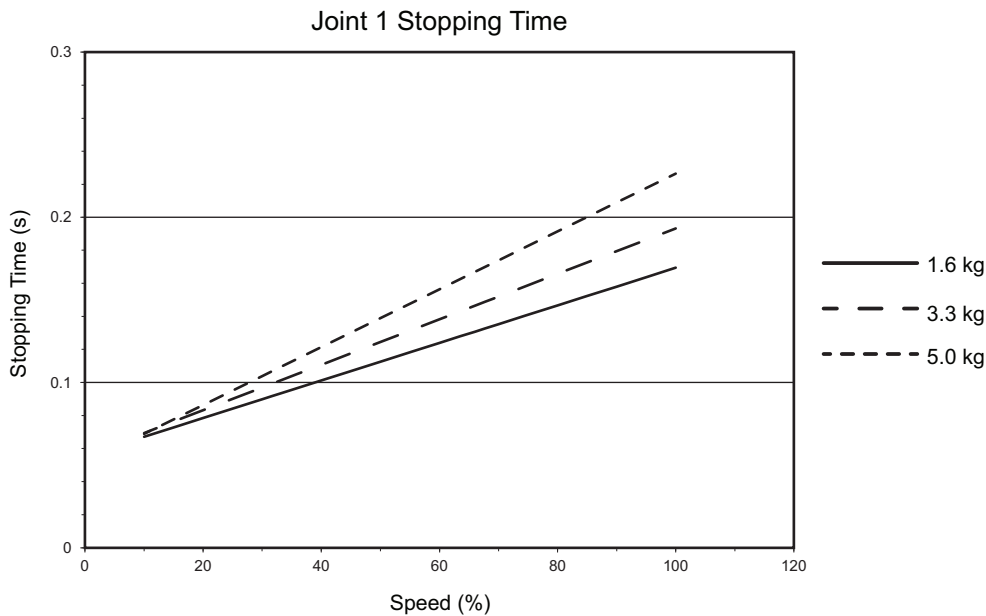

The graphs show the time elapsed and distances traveled between the initiation of a stop signal and the cessation of all robot motion.

For stop category 1, the stopping time and distance values depend on the speed, load, and extension of the robot, stated for 33%, 66% and 100% of the maximum payload (5 kg). Data provided is for the three joints of greatest displacement (J1, J2, and J3).



Joint 1 Stopping Distance

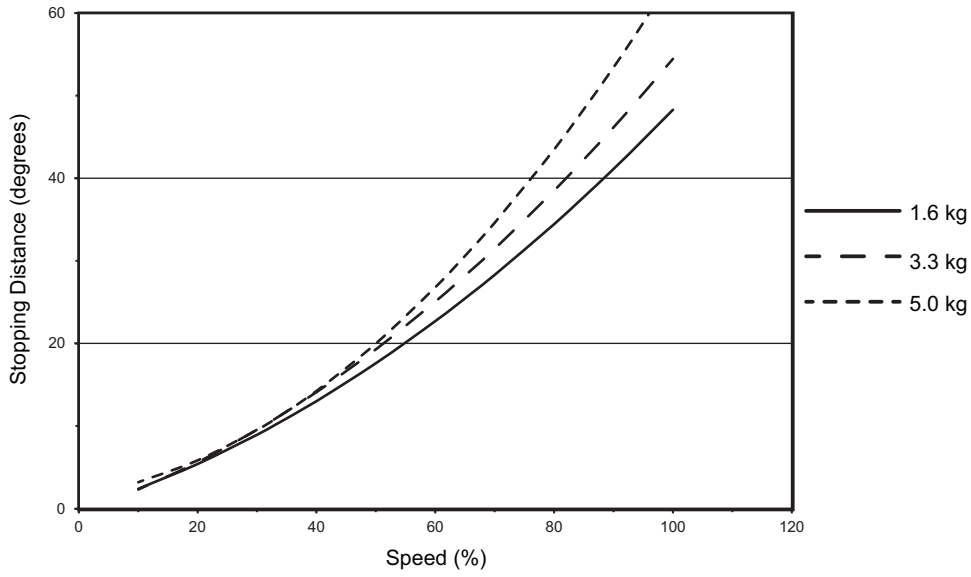

Joint 2 Stopping Time (all payloads)

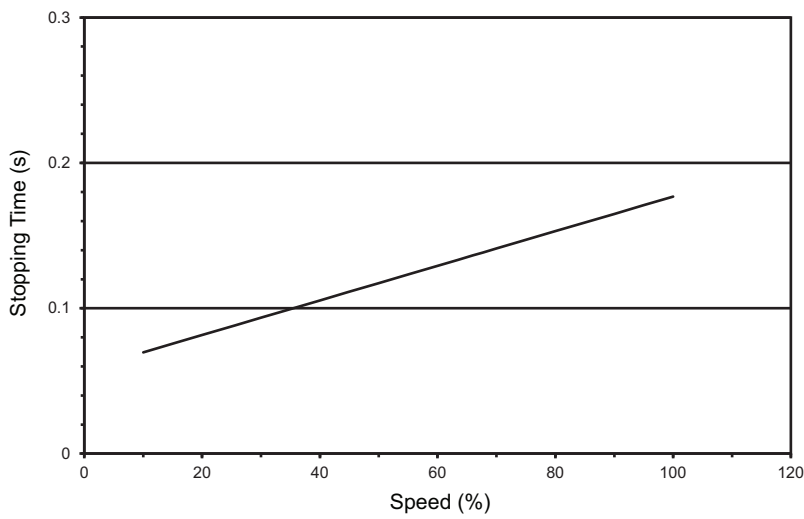

Joint 2 Stopping Distance (all payloads)

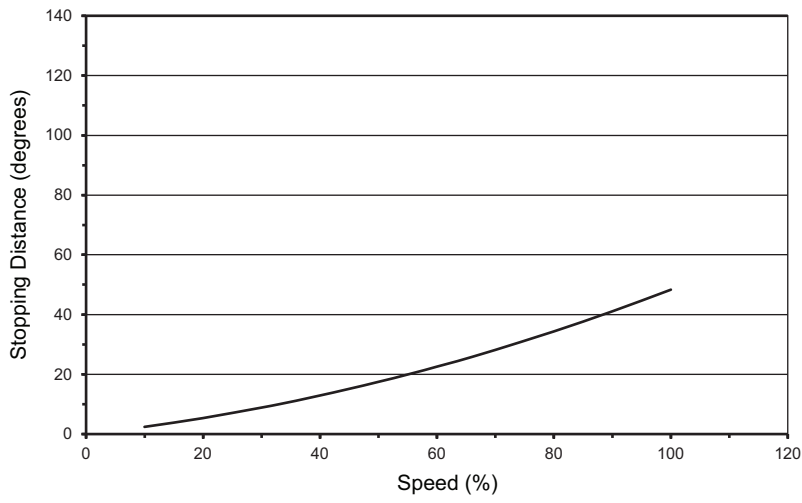

Joint 3 Stopping Time (all payloads)

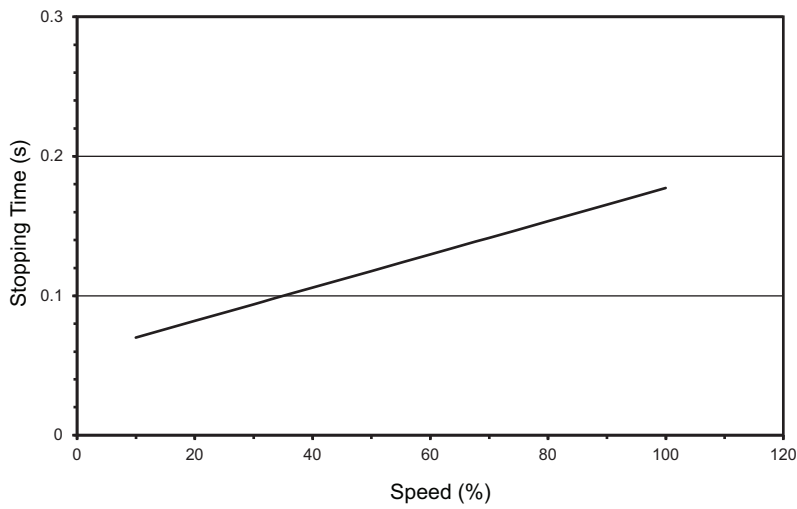

Joint 3 Stopping Distance (all payloads)

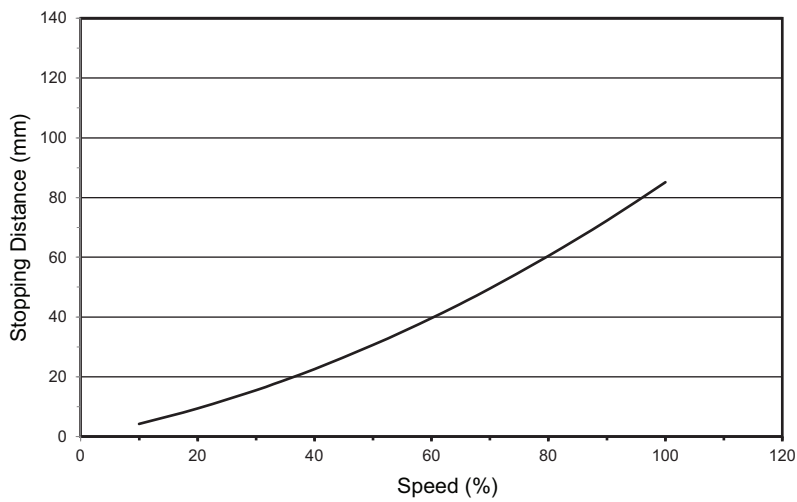

### 2-2-3 Lateral Push Force

The maximum allowable lateral push force at the end-effector is provided below.

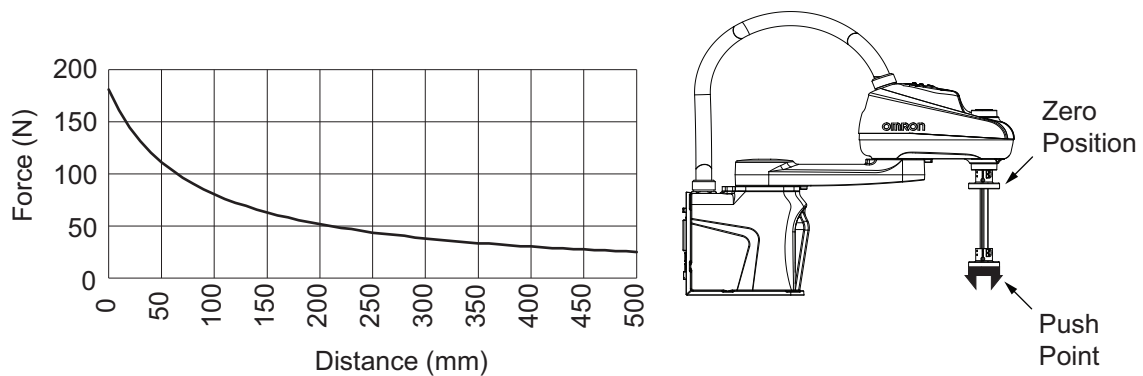

### 2-2-4 Joint 4 Inertia vs. Acceleration

Use the following diagram to understand the limitations to joint 4 acceleration and payload moment of inertia. This diagram provides a general guideline based on typical high-performance use. The practical inertia for any application will vary depending on the performance requirements.

Careful considerations must be made when using high payloads, high accelerations, or a combination of both.

To avoid excessive vibrations, the acceleration limit below is recommended.

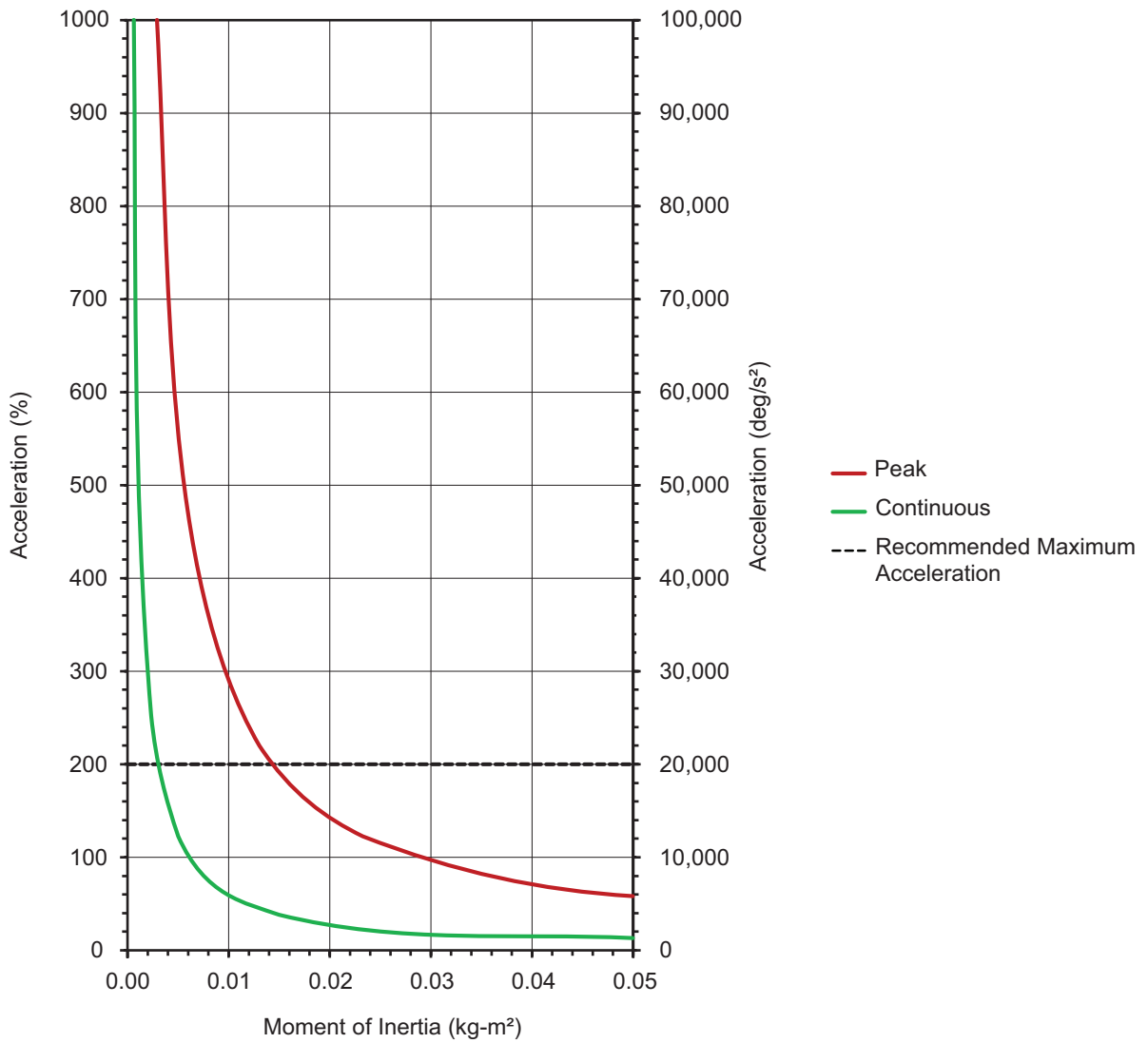

**Additional Information**

- The peak motion profile can be applied for up to 200 ms with a duty cycle of 10%.
- The continuous motion profile can be applied indefinitely with a duty cycle of 100%.

## 2-3 Electrical Specifications

Electrical specifications are provided in the sections below.

### 2-3-1 Power Supply Specifications

Specifications for user-supplied 24 VDC and 48 VDC power supplies are provided below.



#### Additional Information

Refer to the following documents for Control Power Kit and High Power Kit equipment specifications.

- *S8VK-G Series Switch Mode Power Supply Datasheet (Cat. No. T056)*
- *S8VK-R Series Redundancy Unit (Cat. No. T059)*

### User-supplied Control Power Specifications

Item	Specification
Supply voltage range	24 VDC $\pm$ 10%
Current / power requirements	5 A / 120 W maximum
Circuit protection	User-supplied 5 A in-line fuse
Wire size	0.75 mm <sup>2</sup> to 2.5 mm <sup>2</sup>
Shielding	User-supplied connection from power supply cable shield to robot ground point.

### User-supplied High Power Specifications

Item	Specification
Supply voltage range	48 VDC $\pm$ 10%
Current / power requirements	15 A / 720 W rated 20 A / 960 W maximum
Wire size	2.5 mm <sup>2</sup>
Shielding	User-supplied connection from power supply cable shield to robot ground point

### 2-3-2 XIO and TIO Connector I/O Specifications

Specifications for the XIO and TIO connector input and output circuits are provided below.

Type	Item	Specification
Input circuits	Type	Sinking (NPN) / Sourcing (PNP)
	Operational voltage range	0 to 30 VDC
	OFF state voltage range	0 to 3 VDC
	ON state voltage range	10 to 30 VDC
	Typical threshold voltage	8 VDC
	Operational current range	0 to 7.5 mA
	OFF state current range	0 to 0.5 mA
	ON state current range	2.5 to 6 mA
	Typical threshold current	2.0 mA
	Impedance ( $V_{in} / I_{in}$ )	39 k $\Omega$
	Current at 24 VDC	< 6 mA
Output circuits	Type	Sourcing (PNP)
	Output voltage range	24 VDC $\pm$ 10%
	Total current output for all XIO circuits	1.0 A maximum at 50° C ambient temperature 1.5 A maximum at 25° C ambient temperature
	Total current output for all TIO circuits	1.0 A maximum at 50° C ambient temperature 1.5 A maximum at 25° C ambient temperature
	ON state resistance at 0.5A	0.14 $\Omega$ maximum at 85° C
	Output leakage current	5 $\mu$ A maximum
	Short circuit current limit	0.7 to 2.5 A
	Output voltage at inductive load (turn OFF)	(+V - 52) $\leq V_{demag} \leq$ (+V - 41) where $I_{out} =$ 0.5 A and load $\geq$ 1 mH

### 2-3-3 Belt Encoder Specifications

Specifications for the XBELTIO connections are provided below.

Item	Specification
Pulse input method	Line driver
Input signals	A, B, and Z
Counting unit	Pulses
Counter range	-8388607 to 8388608
ON voltage/current	2 to 5 VDC
OFF voltage/current	0 to 0.8 VDC
Input current	100 $\mu$ A
5 VDC output rating	5 VDC $\pm$ 10% 1 A maximum

## 2-4 Environmental Specifications

Environmental specifications are provided below.

 **WARNING**

To reduce the risk of fire or electric shock, install the robot in a controlled environment relatively free of contaminants. 

 **WARNING**

- Do not use the robot in hazardous environments (explosive gas, and oil mist).
- The robot shall be operated within its specified temperature range to ensure proper operation.



Item	Specification
Ambient operating temperature*1	5 to 40°C
Storage temperature	-25 to 55°C
Humidity	5 to 90%, non-condensing
Altitude	2000 m maximum
Pollution degree	2
Protection class	IP20 / NEMA Type 1

\*1. A warm-up is required at low temperatures.

## 2-5 Other Specifications

Other specifications for associated equipment are provided below.

### 2-5-1 Maximum Kinetic Energy

The maximum kinetic energy that the robot can develop is provided below. The values provided apply to all robot type variations.

Robot Type	Maximum Kinetic Energy
i4-350L	73 Joules
i4-450L	99 Joules
i4-550L	161 Joules
i4-550L (350 mm Z)	164 Joules

### 2-5-2 Ethernet Communication Specifications

Ethernet communication specifications are provided below.

Item	Specification
Physical Layer	10BASE-T/100BASE-TX
Media access method	CSMA/CD
Modulation	Baseband
Topology	Star
Baud rate	100 Mbps (100Base-TX)
Transmission media	STP (shielded, twisted-pair) cable of Ethernet category 5, 5e, or higher
Maximum transmission distance between Ethernet switch and node	100 m
Default IP Address	192.168.250.100

### 2-5-3 EtherCAT Communication Specifications

EtherCAT communication specifications are provided below.

Item	Specification
Synchronization	FreeRun and DC (Distributed Clock) with Sync0
Physical layer	100BASE-TX
Modulation	Baseband
Baud rate	100 Mbits/s
Duplex mode	Auto
Topology	Line, ring, and branching
Transmission media	Twisted-pair cable of category 5 or higher Recommended cable: straight, double-shielded cable with aluminum tape and braiding
Maximum transmission distance between nodes	100 m

Item	Specification
Communications cycle	1 ms, 2 ms, 4 ms when SubDevice (robot) configured in DC mode. Any cycle time allowed in the MainDevice when Sub-Device configured in Free-Run mode. For both modes, real-time data about robot status is updated every 4 ms.
Maximum PDO data payload	512 bytes for input and 512 bytes for output.
Node address range	<ul style="list-style-type: none"> <li>• Software setting: 1 to 65534</li> <li>• Switch setting: 1 to 511</li> </ul>
Robot firmware	6.102C or higher.
Robot Controller	Revision B and above.
ACE Software	Version 4.8.3 or higher.
Vendor ID	0x0083 (OMRON Corporation)
Product code	0xA13B4000

## 2-5-4 PROFINET Specifications

PROFINET communication specifications are provided below.

Item	Specification
Protocol	PROFINET v2.4
Class	B
Device profile	Vendor specific I/O
IO connection cycle time*1	4, 8, 16, 32, 64, 128, 512 ms
Maximum data payload	512 bytes for Input and 512 bytes for Output
Sub-slot limit	Slot 1 with V+ variable exchange can contain only 32 sub-slots.
Robot Firmware	Version 6.0C6 and above
Robot Controller	Revision B and above
ACE Software	Version 4.7.3 and above

\*1. IO Connection Cycle Time controls communication interval independent of the robot controller data refresh rate.

## 2-5-5 Connector and Port Specifications

Robot connector specifications are provided below.



### Additional Information

Refer to *Section 3 Installation* on page 3-1 for more information about connector wiring and pin diagrams.

Connector	Specification
Pneumatic pass-through ports	Push-connect type fittings with a maximum air pressure of 0.55 MPa <ul style="list-style-type: none"> <li>• Port A and B fittings: 6 mm</li> <li>• Port C fitting: 4 mm</li> </ul>
USER connectors	15 pin, D-sub, male Rated current: 3 A

Connector	Specification
Control Power connector	Molex 2-wire receptacle Part number: 02708-000F
High Power connector	Molex 3-wire receptacle Part number: 22009-000F
XSYSTEM connector	44 pin, D-sub HD, female
XBELTIO connector	26 pin, D-sub HD, male
XIO connector	26 pin, D-sub HD, female
Ethernet	RJ-45
TIO connector	15 pin, D-sub, female

## 2-5-6 Mounting Hardware and Torques

The following bolt types, washers, and torque is required for mounting the robot.

Type	Quantity	Size	Class	Torque
Socket Head Cap Screw	4	<ul style="list-style-type: none"> <li>M8 x 1.25 mm</li> <li>DIN 912 or ISO 4782</li> </ul>	10.9 or 12.9	30-32 N-m
Flat Washer	4	<ul style="list-style-type: none"> <li>M8</li> <li>DIN 125 or ISO 7089</li> </ul>	8.8	—

### **WARNING**

The robot's center of mass can cause the robot to fall over if the robot is not properly secured with the mounting bolts.



# 3

## Installation

This section provides information about installing the robot and other necessary equipment.





---

<b>3-1</b>	<b>Robot Installation Procedure .....</b>	<b>3-3</b>
<b>3-2</b>	<b>Mounting the Robot .....</b>	<b>3-5</b>
3-2-1	Robot Mounting Surface.....	3-5
3-2-2	Mounting Procedure .....	3-5
<b>3-3</b>	<b>Installing End-of-Arm Tooling .....</b>	<b>3-7</b>
<b>3-4</b>	<b>Installing Optional Equipment .....</b>	<b>3-8</b>
3-4-1	Mounting External Equipment to the Robot.....	3-8
3-4-2	USER Connector Wiring.....	3-9
3-4-3	Bellows Kit Installation Procedure .....	3-9
3-4-4	Pneumatic Valve Kit Installation Procedure.....	3-16
3-4-5	Control Power Kit Connections .....	3-20
3-4-6	High Power Kit Connections.....	3-20
<b>3-5</b>	<b>Adjustable Hardstops .....</b>	<b>3-21</b>
3-5-1	Joint 1 Adjustable Hardstops.....	3-22
3-5-2	Joint 2 Adjustable Hardstops.....	3-22
3-5-3	Joint 3 Adjustable Hardstop .....	3-22
<b>3-6</b>	<b>System Cable Installation .....</b>	<b>3-24</b>
3-6-1	System Cable Overview .....	3-24
3-6-2	System Cable Installation Procedure .....	3-28
<b>3-7</b>	<b>Connecting Digital I/O.....</b>	<b>3-29</b>
3-7-1	XIO Connector Signals and Wiring.....	3-29
3-7-2	TIO Connector Signals and Wiring.....	3-33
3-7-3	IO Blox Connections.....	3-35
<b>3-8</b>	<b>Installing Safety Equipment .....</b>	<b>3-37</b>
3-8-1	Installing the Front Panel.....	3-37
3-8-2	Safety Circuits .....	3-38
<b>3-9</b>	<b>Setting the EtherCAT Node ID.....</b>	<b>3-45</b>
3-9-1	EtherCAT Node ID Setting Example .....	3-45
<b>3-10</b>	<b>Supplying Power and Ground.....</b>	<b>3-47</b>
3-10-1	Grounding the System.....	3-47
3-10-2	Power Connections .....	3-47
<b>3-11</b>	<b>Verifying Installation .....</b>	<b>3-50</b>
3-11-1	Mechanical Checks .....	3-50

3-11-2	System Cable Checks .....	3-50
3-11-3	Safety Equipment Checks .....	3-50
3-11-4	Switch Position Checks .....	3-52

## 3-1 Robot Installation Procedure

The basic installation steps are provided below.

 <b>DANGER</b>	
<ul style="list-style-type: none"> <li>• After installing the robot, you must test it before you use it for the first time. Failure to do this could cause death, serious injury, or equipment damage.</li> <li>• Any change to the robot can lead to loss in safety or functionality. It is the user's responsibility to perform a risk assessment for the whole (modified) robot after any such changes and to confirm that all safety features of the robot are operational.</li> </ul>	
 <b>WARNING</b>	
<ul style="list-style-type: none"> <li>• Ensure that installation and post-installation checks of the product are performed by personnel in charge who possess a thorough understanding of the machinery to be installed.</li> <li>• The robot must be installed to avoid interference with buildings, structures, utilities, other machines and equipment that may create trapping or pinch points. It must be installed in accordance with Standard for Robots and Robotic Devices – Safety Requirements for Industrial Robots – Part 2: Robot Systems and Integration, ISO 10218-2.</li> </ul>	



### Additional Information

Refer to *A-1 Unpacking and Inspecting the Robot* on page A-2 for more information.

- 1** Mount the robot.  
Refer to *3-2 Mounting the Robot* on page 3-5 for more information.
- 2** Install the end-of-arm tooling.  
Refer to *3-3 Installing End-of-Arm Tooling* on page 3-7 for more information.
- 3** Install any equipment such as cameras, solenoid valves, a Front Panel, or bellows.  
Refer to *3-4 Installing Optional Equipment* on page 3-8 for more information.
- 4** Connect any necessary pneumatic air lines using the pass-through ports.  
Refer to *2-5-5 Connector and Port Specifications* on page 2-19 for more information.
- 5** Make any necessary adjustments to hardstops.  
Refer to *3-5 Adjustable Hardstops* on page 3-21 for more information.
- 6** Connect all required system cables.  
Refer to *3-6 System Cable Installation* on page 3-24 and *3-7 Connecting Digital I/O* on page 3-29 for more information.
- 7** Connect all required safety equipment.  
Refer to *3-8 Installing Safety Equipment* on page 3-37 for more information.
- 8** Make power and ground connections.

Refer to *3-10 Supplying Power and Ground* on page 3-47 for more information.

- 9** Verify the robot installation to complete the procedure.  
Refer to *3-11 Verifying Installation* on page 3-50 for more information.

## 3-2 Mounting the Robot

Use the information in the following sections to mount the robot.

### 3-2-1 Robot Mounting Surface

The following considerations must be made when preparing a robot mounting surface.

- It must be smooth and flat.
- It must be rigid enough to prevent vibration and flexing that is caused by reactionary forces during fast robot motion.
- It must be designed to support the weight of the robot with payload.
- Table-mounted robots must be placed on a level, horizontal surface.
- Wall-mounted robots must be fastened to a 90° vertical surface.
- When the robot is mounted to a vertical surface, considerations for preventing a collision with the mounting surface should be made.

#### **WARNING**

If a robot is mounted to a surface with inadequate stiffness, damage to the z-axis quill or other mechanical components can result from excessive oscillation during operation.



#### **Precautions for Correct Use**

- It is recommended to use a properly secured, 18 mm (minimum) thick steel plate with a maximum surface roughness of 25 µm as a robot mounting surface.
- Keep a minimum of 300 mm clearance from the Primary Interface Panel to allow for switch and cable connection access.

### 3-2-2 Mounting Procedure

Use the following procedure to mount the robot.

#### **WARNING**

- Always use proper lifting technique when lifting the robot. Failure to comply could result in the robot falling and causing either personnel injury or equipment damage.
- The robot's center of mass can cause the robot to fall over if the robot is not properly secured with the mounting bolts.



#### **Precautions for Safe Use**

The robot can be lifted by hand. Only use the base and inner link when lifting the robot. Never maneuver the robot using the quill or flyover assemblies.



#### **Precautions for Correct Use**

The mounting surface should be clean and prepared according to the information provided in *3-2-1 Robot Mounting Surface* on page 3-5 before attempting to mount the robot.



### Additional Information

---

After mounting the robot, check the mounting bolt torque after 72 hours of initial operation and then recheck every 3 months thereafter. Refer to *6-1 Periodic Maintenance* on page 6-2 for more information.

---

Before beginning the mounting procedure, have the following tools and resources available. Prepare the mounting holes before beginning the mounting procedure.

- Prepare the mounting holes.
- A torque wrench for proper tightening of the mounting bolts.
- Assistance to lift and maneuver the robot into the mounting position.
- Four socket-head cap screws with flat washers. Refer to *2-5-6 Mounting Hardware and Torques* on page 2-20 for more information.

- 1** Using the dimensions provided in *2-1-2 Mounting Flange Dimensions* on page 2-4, prepare four holes in the mounting surface to accommodate the user-supplied machine screws (specified above). A slot and hole are provided in the mounting flange for dowel pins.
- 2** Maneuver the robot into position on the mounting surface.
- 3** Align the holes in the mounting flange with the prepared mounting holes in the mounting surface.
- 4** Insert all four screws with washers to secure the robot to the mounting surface.
- 5** Tighten the four screws to 31 N-m of torque.  
After all four screws have been tightened to the specified torque, the mounting procedure is complete.

## 3-3 Installing End-of-Arm Tooling

You must provide, install, and ground (if necessary) end-of-arm tooling to the tool flange.

Use the following details when designing and installing end-of-arm tooling.

- Hole diameters and placement on the tool flange comply with ISO-9409-1-50-4-M6 (2004) standards.
- End-of-arm tooling is attached to the tool flange using M6 x 1.0 (Class 10.9 or higher) screws with a minimum of 10 mm thread engagement into the tool flange.
- Apply Loctite 243 thread lock (or equivalent) to secure the screws.
- Apply a torque of 7.5 N-m when tightening tooling screws.



### Additional Information

Refer to *2-1-3 Tool Flange Dimensions* on page 2-5 for more information.

If the end-of-arm tooling requires pneumatic or electrical connections, use the pass-through connections from the Primary Interface Panel to the Secondary Interface Panel. Refer to *1-2-4 Connectors and Ports* on page 1-8 for more information.



### Precautions for Safe Use

The Joint 3 quill and the tool flange are not grounded to protective earth. If hazardous voltages are present at any user-supplied robot-mounted equipment or tooling, you must install a ground connection from that equipment or tooling to the ground point on the robot base.

Refer to *3-10-1 Grounding the System* on page 3-47 for more information about grounding the tool flange.

## DANGER

Failure to ground robot-mounted equipment or tooling that uses hazardous voltages could lead to injury or fatality of a person touching the end-effector during an electrical fault.



## 3-4 Installing Optional Equipment

This section provides information about installing the following optional equipment.

### 3-4-1 Mounting External Equipment to the Robot

The robot body has accommodations to mount external equipment such as a camera or solenoid valves. Use the information below to understand how to mount external equipment to the robot.

4 mounting holes are provided on the bottom of the outer link between joint 2 and joint 4.

2 mounting holes are provided on the bottom and near the end of the outer link.

The following considerations should be made when mounting external equipment to the robot.

- Do not mount equipment that will interfere with robot motion or other objects in the work cell.
- Do not mount equipment in a way that can induce excessive inertia to the outer link.
- Mounting holes are thru-type and the robot body is 6.5 mm thick. Do not use fasteners that can extend into the body of the robot. This can interfere with internal components.



#### Precautions for Correct Use

Any externally mounted equipment is considered robot payload. Consideration to the payload attached to the Tool Flange should be made when mounting external equipment to the robot.

Apply a torque of 2.5 N-m to the user-supplied fasteners when mounting equipment to the 4 mounting holes between joint 2 and joint 4. Apply Loctite thread lock type 222 or equivalent.

Apply a torque of 4.5 N-m to the user-supplied fasteners when mounting equipment to the 2 mounting holes at the end of the outer link. Apply Loctite thread lock type 243 or equivalent.

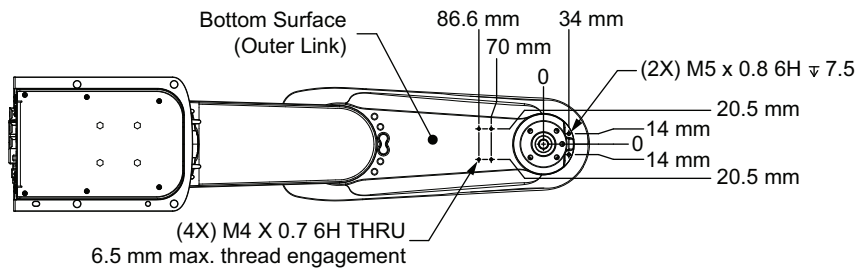

The z-axis quill has a hollow shaft design and can be utilized for routing cables and pneumatic lines to an end-effector. The inner diameter of this hollow shaft is 11 mm.

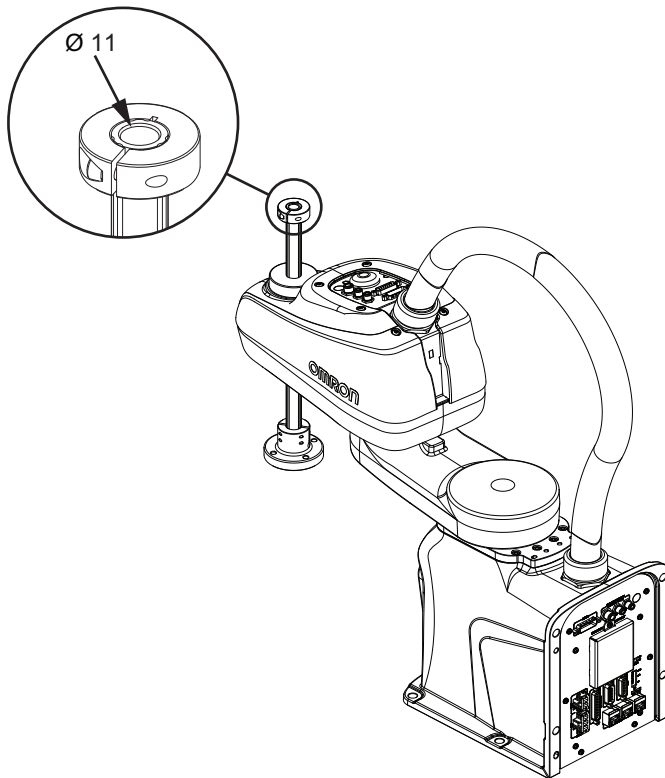

### 3-4-2 USER Connector Wiring

Use the information below to make connections to the USER connectors on the Primary Interface Panel and the Secondary Interface Panel.

There are no twisted-pair conductors between the USER connectors on the Primary Interface Panel and the Secondary Interface Panel. Data communication is not recommended for these connectors.



#### Additional Information

Refer to *2-5-5 Connector and Port Specifications* on page 2-19 for more information about the USER connector type.

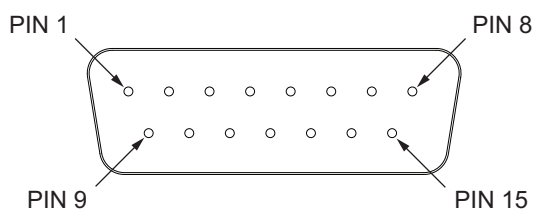

### 3-4-3 Bellows Kit Installation Procedure

Use the following procedure to install bellows.



### Precautions for Correct Use

- Never loosen or remove the quill clamp collar while the z-axis brake is released.
- The z-axis stroke is reduced when bellows are present. Bellows reduce the travel by 27 mm (180 mm quill length) / 53 mm (350 mm quill length) in the z-axis retracted position and 27 mm (180 mm quill length) / 53 mm (350 mm quill length) in the z-axis extended position. Always adjust joint motion limits with software settings in the robot configuration area when bellows are installed to restrict range of motion. Refer to the *Automation Control Environment (ACE) Version 4 User's Manual (Cat. No. I633)* for more information.

The following items are required for this procedure.

- Bellows kit. Refer to *1-6-7 Bellows Kit* on page 1-21 for more information.
- Torque wrench.
- 2.5 mm, 3 mm, 4 mm hex bits.
- T8 torx bit.

Make the following considerations before installing the bellows.

- If cables or tubing are routed through the center of the quill, they must be removed before beginning this procedure.
- The tool flange must be removed. Make all necessary preparations and considerations before removing the tool flange.
- The outer link cover must be removed. Make all necessary preparations and considerations before removing the outer link cover.
- This procedure installs the upper bellows first and then the lower bellows next.
- To simplify installation, the Joint 3 quill should be positioned in approximately the middle position before beginning this procedure.
- The upper and lower bellows are identical and interchangeable.

The bellows kit includes the following main components.

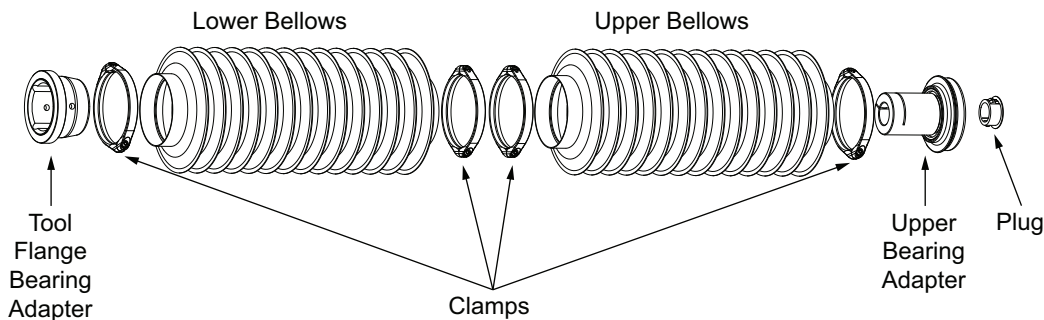

- 1 Begin the upper bellows installation by removing the quill clamp collar at the top of the Joint 3 quill and the tool flange using 3 and 4 mm hex bits. The quill clamp collar will be replaced by the upper bearing adapter provided in the bellows installation kit.

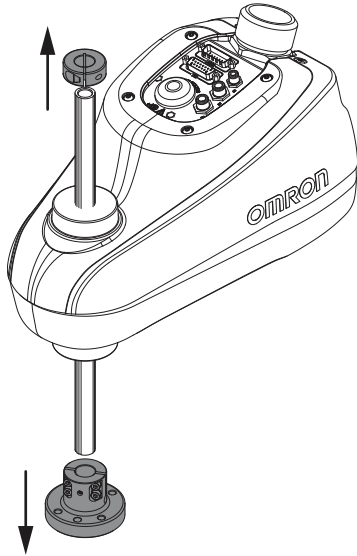

- 2** Slide the bellows (22861-000) down the quill and then wrap it around the exterior of the robot housing. Orientation of the bellows must be correct. Ensure the taller bellows collar is mated with the robot housing. Take care to ensure the bellows is wrapped evenly and completely around the robot housing.

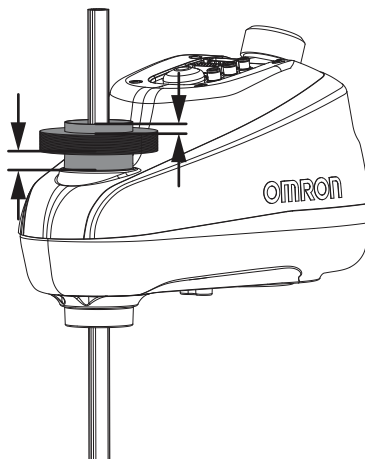

- 3** Place the two halves of the clamp (22852-000) around the robot housing. Orient the clamp so that the clamp fasteners (22919-000) can be inserted as shown in the image below.

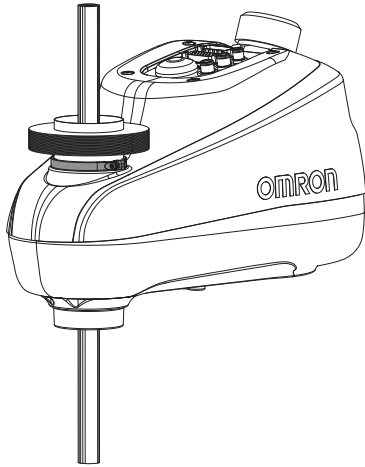

- 4** Apply thread lock (87002-00680) to the clamp fasteners, insert, and tighten using an T8 torx bit while ensuring that the bellows are completely seated and positioned between the small clamp and the robot housing. Tighten to a torque of 2.4 N-m.
- 5** Place the upper bearing adapter on the top of the quill. Ensure the upper bearing adapter is completely seated on top of the quill.

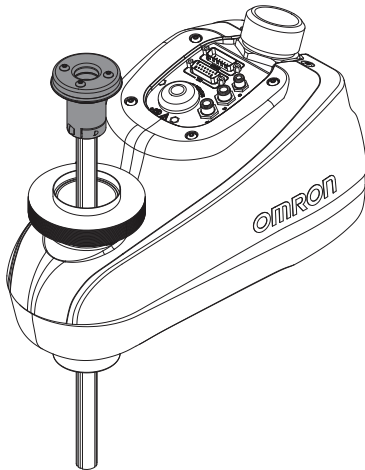

- 6** Apply thread lock to the upper bearing adapter clamp screw (51000-67016), insert, and tighten using a 3 mm hex bit to a torque of 1.3 N-m.
- 7** Lift the bellows upward and wrap it over the outer circumference of the upper bearing adapter. This may require stretching the bellows slightly so it can be positioned over the upper bearing adapter lip.

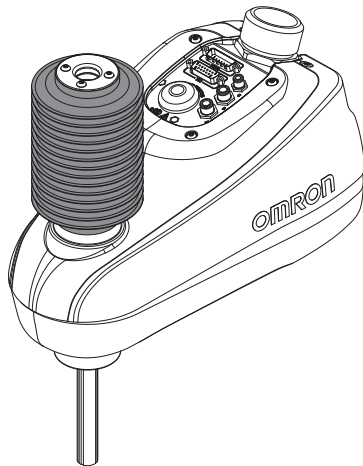

- 8** Place the two halves of the clamp on the upper bearing adapter. The bellows should be evenly positioned between the upper bearing adapter and the clamp.

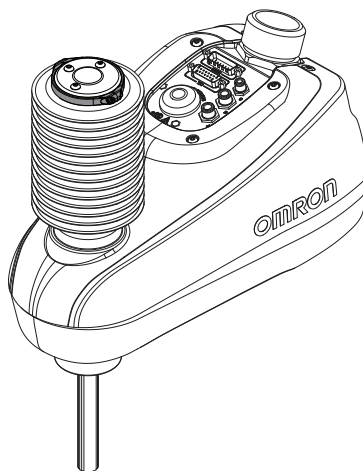

- 9** Apply thread lock to the clamp fasteners, insert, and tighten using an T8 torx bit while ensuring that the bellows are completely seated and positioned between the clamp and the upper bearing adapter. Tighten to a torque of 2.4 N-m.
- 10** If routing cables or lines through the center of the quill is not required, insert the plug (22921-000) into the upper bearing adapter to complete the installation of the upper bellows.
- 11** Begin the lower bellows installation by sliding the bellows up the quill and then wrap it around the exterior of the robot housing. Orientation of the bellows must be correct. Ensure the taller bellows collar is mated with the robot housing (refer to step 2 above). Take care to ensure the bellows is wrapped evenly and completely around the robot housing.

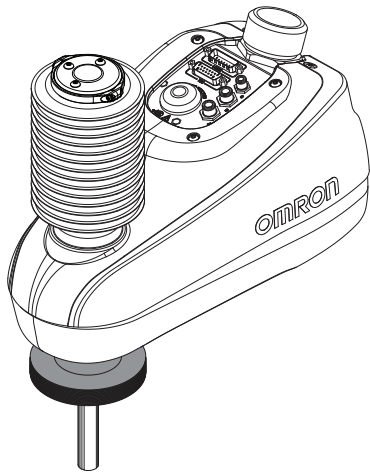

**12** Place the two halves of the clamp around the robot housing.

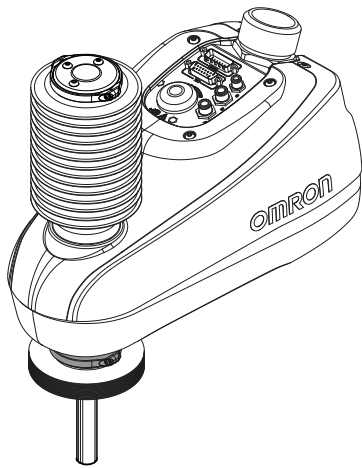

**13** Apply thread lock to the clamp fasteners, insert, and tighten using an T8 torx bit while ensuring that the bellows are completely seated and positioned between the clamp and the robot housing. Tighten to a torque of 2.4 N-m.

**14** Slide the tool flange bearing adapter (1) up the quill and then move the tool flange into its original position (2).

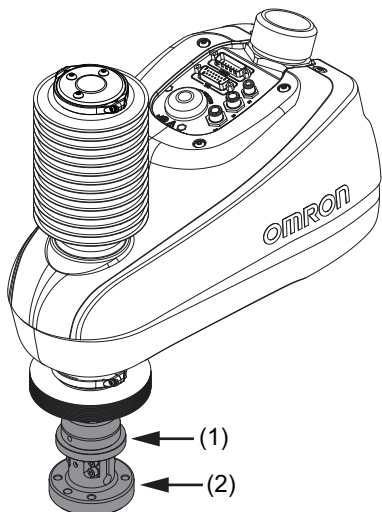

- 15** Apply thread lock to the tool flange setscrew and then tighten to a torque of 1.1 N-m using a 2.5 mm hex bit.

Do not over-tighten the tool flange setscrew. This will cause off-center alignment of the tool flange on the quill.

- 16** Apply thread lock to the tool flange socket-head screws and then use a torque wrench with a 4 mm hex bit to tighten one of the socket-head screws to 1 N-m. Then, apply the same torque to the other socket-head screws. Finally, tighten each socket-head screw to 2.5 N-m torque.

- 17** Position the tool flange bearing adapter on the tool flange.  
Ensure the bearing adapter is completely mated to the tool flange.

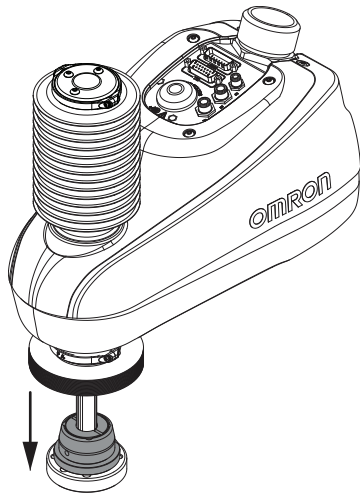

- 18** Rotate the tool flange bearing adapter to ensure that the setscrews will make contact with a flush surface of the tool flange.

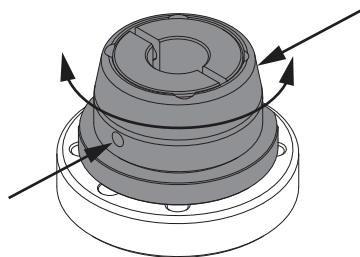

- 19** Apply thread lock to the tool flange bearing adapter setscrews (51410-000), insert them, and then tighten using a 2.5 mm hex bit to a torque of 1.1 N-m.  
Ensure the tool flange bearing adapter is completely mated to the tool flange before tightening the setscrews.

- 20** Wrap the bellows over the outer circumference of the tool flange bearing adapter.  
This may require stretching the bellows slightly so it can be positioned over the tool flange bearing adapter lip.

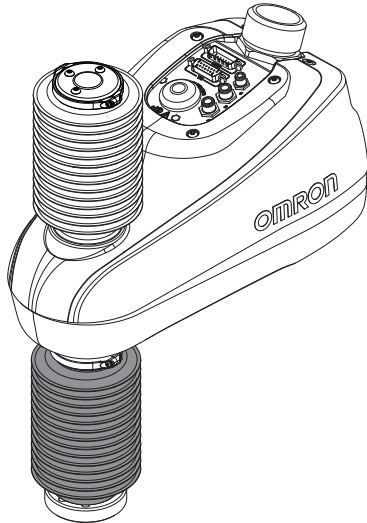

**21** Place the clamp on the tool flange bearing adapter.

The bellows should be evenly positioned between the tool flange bearing adapter and the clamp.

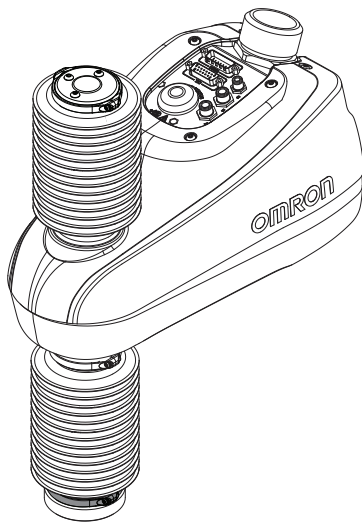

**22** Apply thread lock to the clamp fasteners, insert, and tighten using an T8 torx bit while ensuring that the bellows are completely seated and positioned between the clamp and the tool flange bearing adapter. Tighten to a torque of 2.4 N-m.

**23** Reduce joint motion limits with software settings in the robot configuration area when bellows are installed to restrict range of motion. Refer to the *Automation Control Environment (ACE) Version 4 User's Manual (Cat. No. I633)* for more information.

After the joint limits are reduced, the bellows installation procedure is complete.

### 3-4-4 Pneumatic Valve Kit Installation Procedure

Use the following procedure to install the pneumatic valve kit.

The following items are required for this procedure.

- 2.5 mm, 3 mm hex bit.
- 6 mm socket.

- Slotted screw driver.
- Cutters.

Make the following considerations before installing the pneumatic valve kit.

- The outer link cover must be removed. If bellows are installed, the upper assembly must be removed before beginning this procedure. Refer to *3-4-3 Bellows Kit Installation Procedure* on page 3-9 and reverse installation steps to remove and replace the upper bellows assembly.

The pneumatic valve kit includes the following main components.

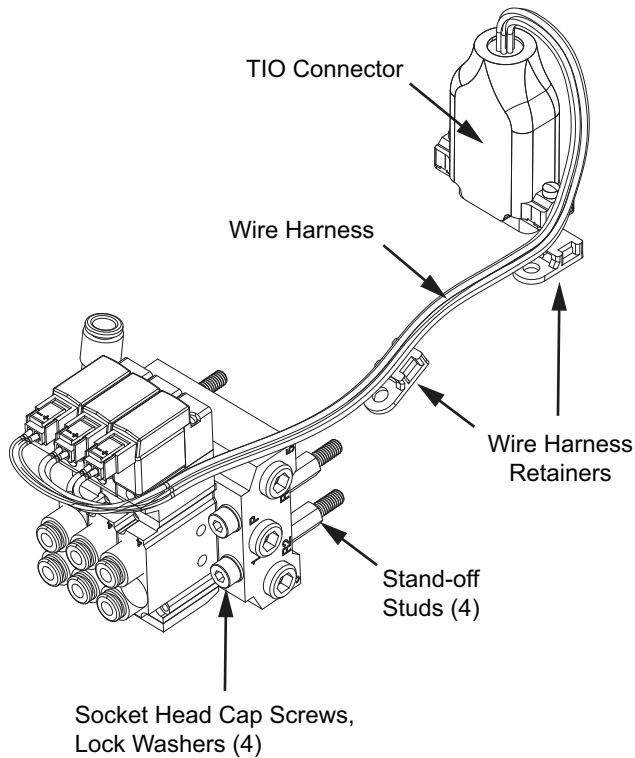

- 1 Remove six outer link cover fastening screws using a 2.5 mm hex bit and then remove the outer link cover.

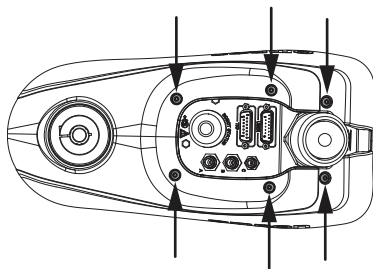

- 2 Drill four 8 mm diameter holes in the back of the outer link. Drill from the inside of the cover. Use the indentations shown below for the hole locations.

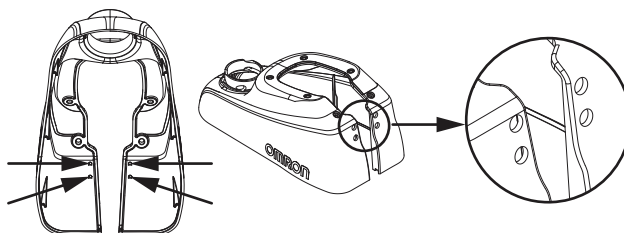

- 3** Place the outer link cover on the robot in its original position.
- 4** Replace four of the outer link cover fastening screws as indicated below.  
Apply thread lock to the screws and tighten using a 2.5 mm hex bit to a torque of 2.9 N-m.

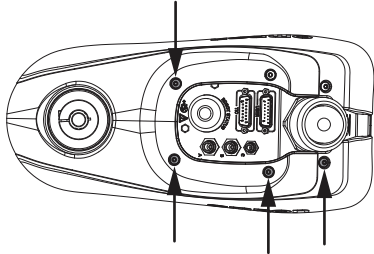

- 5** Fasten two wire harness retaining clips (23477-000) to the outer link using two screws that were previously removed in the locations shown below.  
Apply thread lock to the screws and tighten using a 2.5 mm hex bit to a torque of 2.9 N-m.

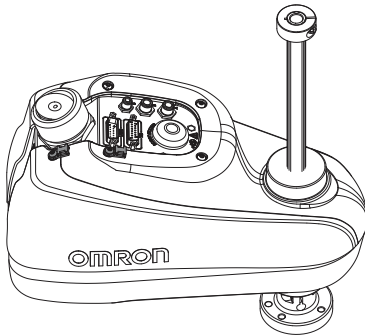

- 6** Screw the stand-off studs (22873-000) into the inner bracket.  
Apply thread lock to the stand-off studs and tighten using a 6 mm socket to a torque of 2.9 N-m.

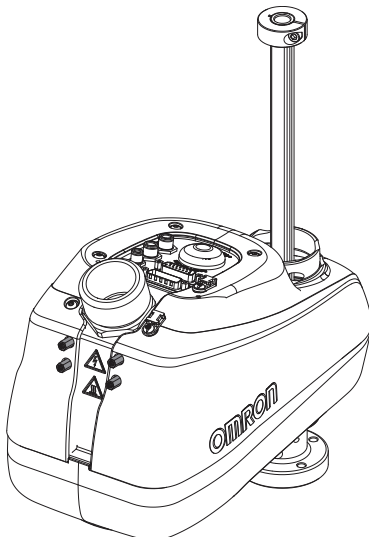

- 7** Place the pneumatic valve assembly near the stand-off studs and then insert four socket head cap screws (51006-67025) with lock washers (18913-000) into the valve manifold to secure it to the robot in the orientation shown below.  
Apply thread lock to the socket head cap screws and tighten using a 3 mm hex bit to a torque of 2.9 N-m.

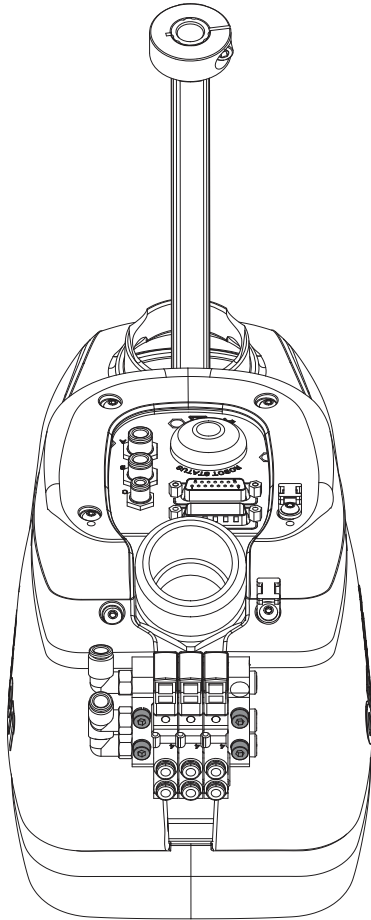

- 8** Connect the wire harness as shown below.

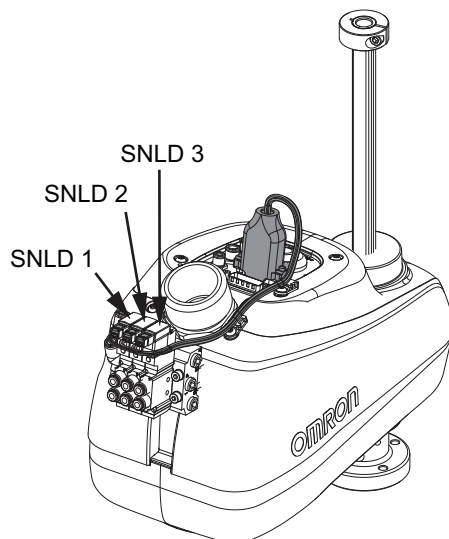

- 9** Tighten the wire harness TIO connector retaining screws using a slotted screwdriver.
- 10** Secure the wire harness to the robot by inserting two cable ties (27300-00024) through the wire harness retaining clips and then around the wire harness.  
Trim excess cable tie material placement using cutters to complete this procedure.

### 3-4-5 Control Power Kit Connections

Use the following diagram to connect the Control Power Kit to the robot.

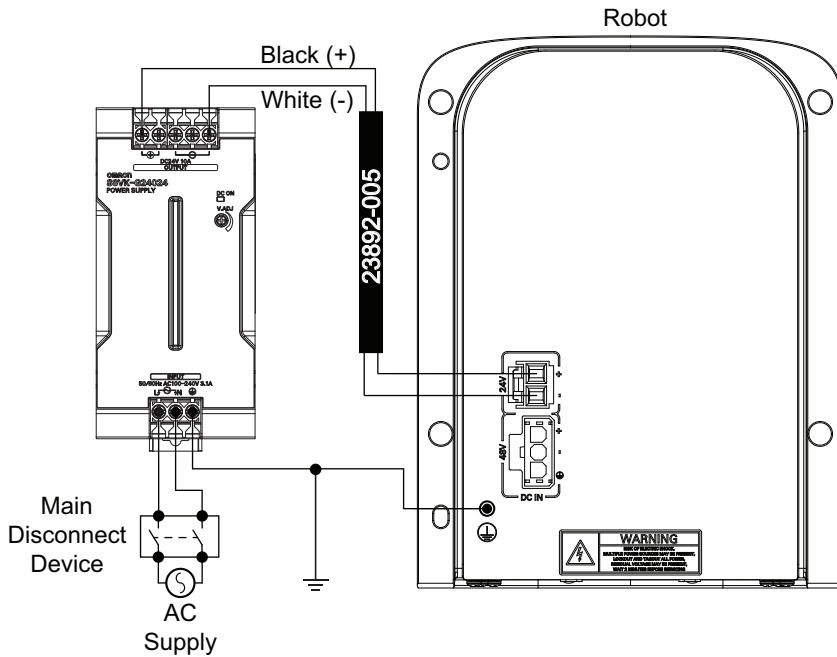

### 3-4-6 High Power Kit Connections

Use the following diagram to connect the High Power Kit to the robot.

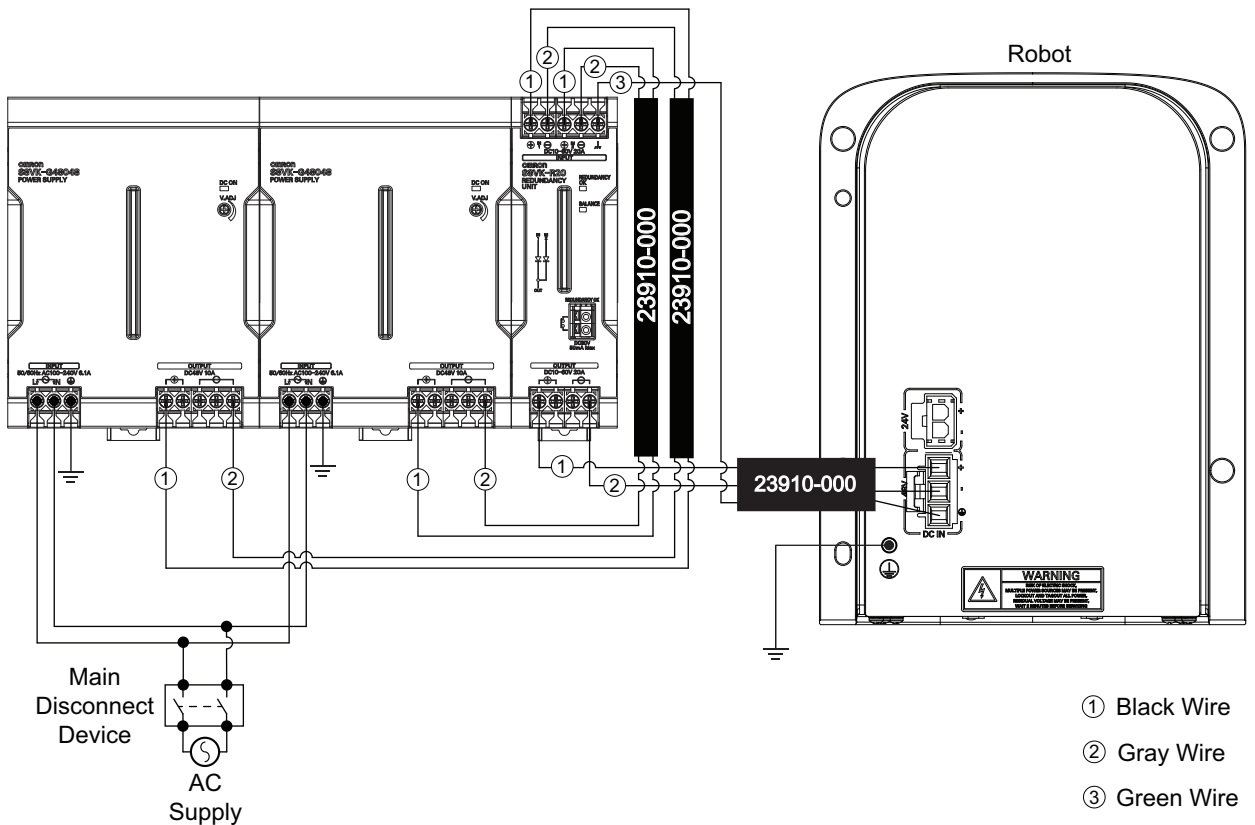

## 3-5 Adjustable Hardstops

The robot is equipped with several mechanical hardstop adjustment points for joints 1, 2, and 3 as described in the following sections. Adjust these mechanical hardstops to restrict the robot's range of motion in order to prevent collisions within the workspace if necessary.

### WARNING

The robot's physical hardstop devices are not intended to withstand repeated use and if this occurs, the hardstop may become damaged. Implement proper programming and configuration of joint range limits to prevent hardstop impacts.



#### Precautions for Correct Use

Always reduce joint motion limits with software settings in the robot configuration area when hardstops are used to restrict range of motion. Refer to the *Automation Control Environment (ACE) Version 4 User's Manual (Cat. No. I633)* for more information.



#### Additional Information

- Obstacles may be defined with software configuration to restrict the robot tool-tip from entering specified volumes of the work envelope. Refer to the *Automation Control Environment (ACE) Version 4 User's Manual (Cat. No. I633)* for more information.
- Refer to 2-1-6 *Robot Work Envelope Dimensions* on page 2-6 for full range of motion values.

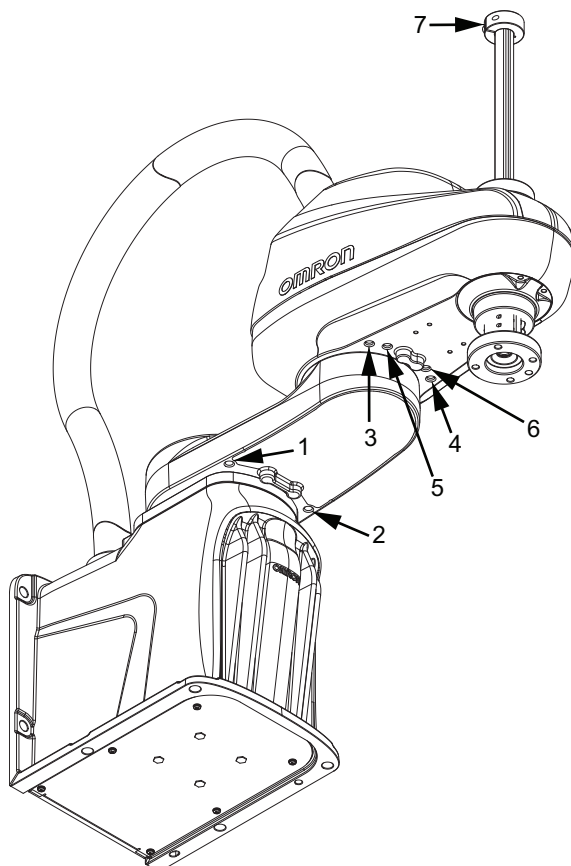

Joint Hardstop Position	Joint Limitation	Range of Motion Software Limit Setting		
		i4-350L	i4-450L	i4-550L / i4-550L (350 mm Z)
1	Joint 1	-109.5°		
2		+109.5°		
3	Joint 2	-124°	-118°	
4		+124°	+118°	
5		See note*1	-133°	
6			+133°	
7	Joint 3	5 mm from end of travel.		

\*1. The i4-350L model includes pre-installed hardstop screws in positions 5 and 6 to prevent base interference with the quill. Do not remove these pre-installed hardstop screws.

### 3-5-1 Joint 1 Adjustable Hardstops

Use the following information when making joint 1 hardstop adjustments.

- Four M8 X 10 socket head cap screws, class 12.9 are supplied with the robot for use as Joint 1 and Joint 2 adjustable hardstops.
- Apply Loctite thread lock type 243 or equivalent.
- Apply a torque of 17 N-m when tightening the hardstop screws.

### 3-5-2 Joint 2 Adjustable Hardstops

Use the following information when making joint 2 hardstop adjustments.

- Four M8 X 10 socket head cap screws, class 12.9 are supplied with the robot for use as Joint 1 and Joint 2 adjustable hardstops.
- Apply Loctite thread lock type 243 or equivalent.
- Apply a torque of 17 N-m when tightening the hardstop screws.

### 3-5-3 Joint 3 Adjustable Hardstop

The joint 3 down stroke can be limited by sliding the clamp collar down the z-axis quill to a lower position.

The following tools are required when adjusting the joint 3 hardstop.

- 4 mm hex bit
- Torque wrench
- Loctite thread lock type 243 or equivalent



#### Precautions for Correct Use

Never loosen or remove the quill clamp collar while the z-axis brake is released.

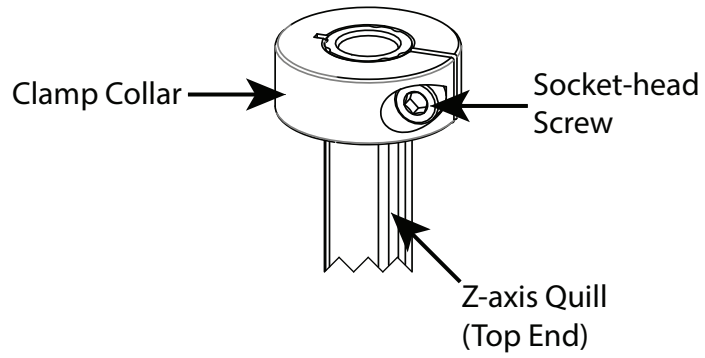

Loosen the clamp collar socket-head screw and slide the clamp to the appropriate location to limit the down stroke of the z-axis quill. When the clamp is in the desired location, apply thread lock and tighten the socket-head screw to a torque of 4.5 N-m.

## 3-6 System Cable Installation

This section provides information about installing the robot system cables.

### **WARNING**

- Never connect or disconnect system cables while power is applied to the robot. Failure to comply may cause unexpected behavior and can result in personnel injury and equipment damage.
- Provide appropriately-sized Branch Circuit Protection and Lockout / Tagout Capability in accordance with the National Electrical Code and any local codes.
- Ensure that interconnecting cables or pneumatic lines are routed away from the robot workspace.
- Ensure compliance with all local and national safety and electrical codes for the installation and operation of the robot system.



### 3-6-1 System Cable Overview

Standard and optional cable connections are provided below.

#### Standard Connections

The following figure shows standard connections with the XSYSTEM cable. This cable is supplied with the robot.



### Additional Information

Refer to 3-8 *Installing Safety Equipment* on page 3-37 for more information about XFP, XUSR, and XMCP connections.

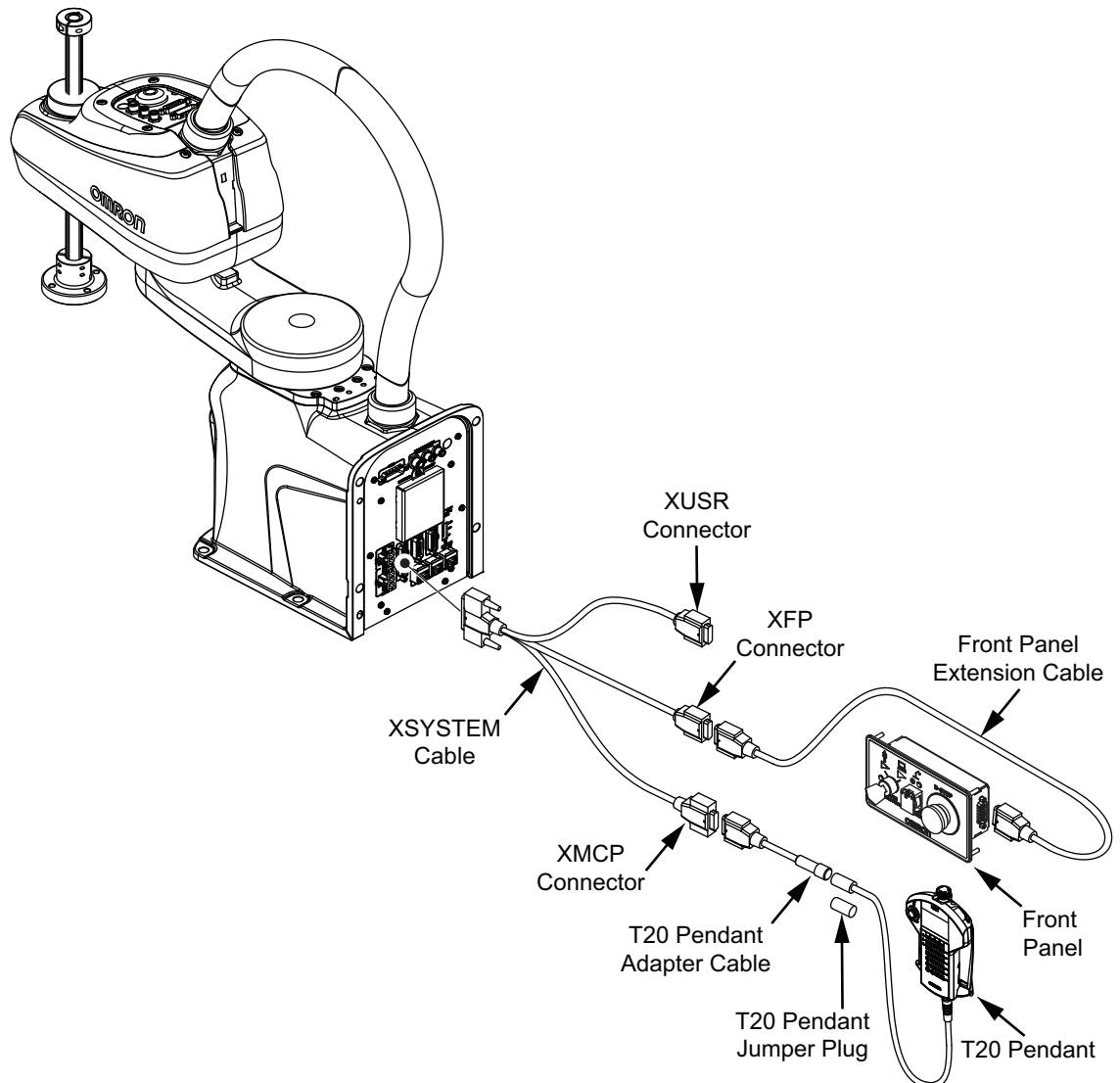

## EtherCAT Connections

The following figure shows typical connections with an EtherCAT MainDevice. A line topology connection method is shown. Other topologies such as ring are possible. Refer to the EtherCAT MainDevice documentation for more information.

### ⚠ CAUTION

Always physically disconnect the robot from the EtherCAT network before disabling its EtherCAT communication.





### Precautions for Safe Use

Fieldbus communications are not secure. Additional measures must be taken if compliance with security standards is required.



### Additional Information

EtherCAT SubDevice functionality is not enabled by default. Enabling the EtherCAT fieldbus automatically configures and activates the robot's network ports for that specific fieldbus communication. By default, all ports are set for Ethernet communication when no fieldbus is active. Refer to *Automation Control Environment (ACE) Version 4 User's Manual (Cat. No. I633)* and *Industrial Robot Fieldbus Configuration User's Guide (Cat. No. M130)* for more information about enabling EtherCAT communications.

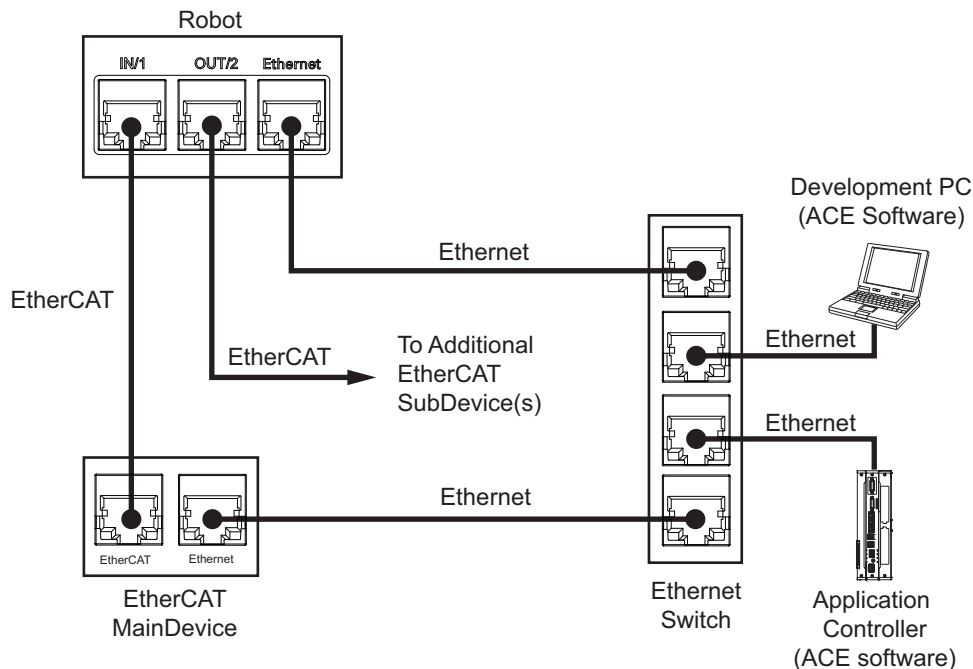

## Optional Connections

The following figure shows optional connections to the robot.



### Additional Information

Refer to *3-7 Connecting Digital I/O* on page 3-29 for more information about connecting I/O with IO Blox Units or with the XIO connector.

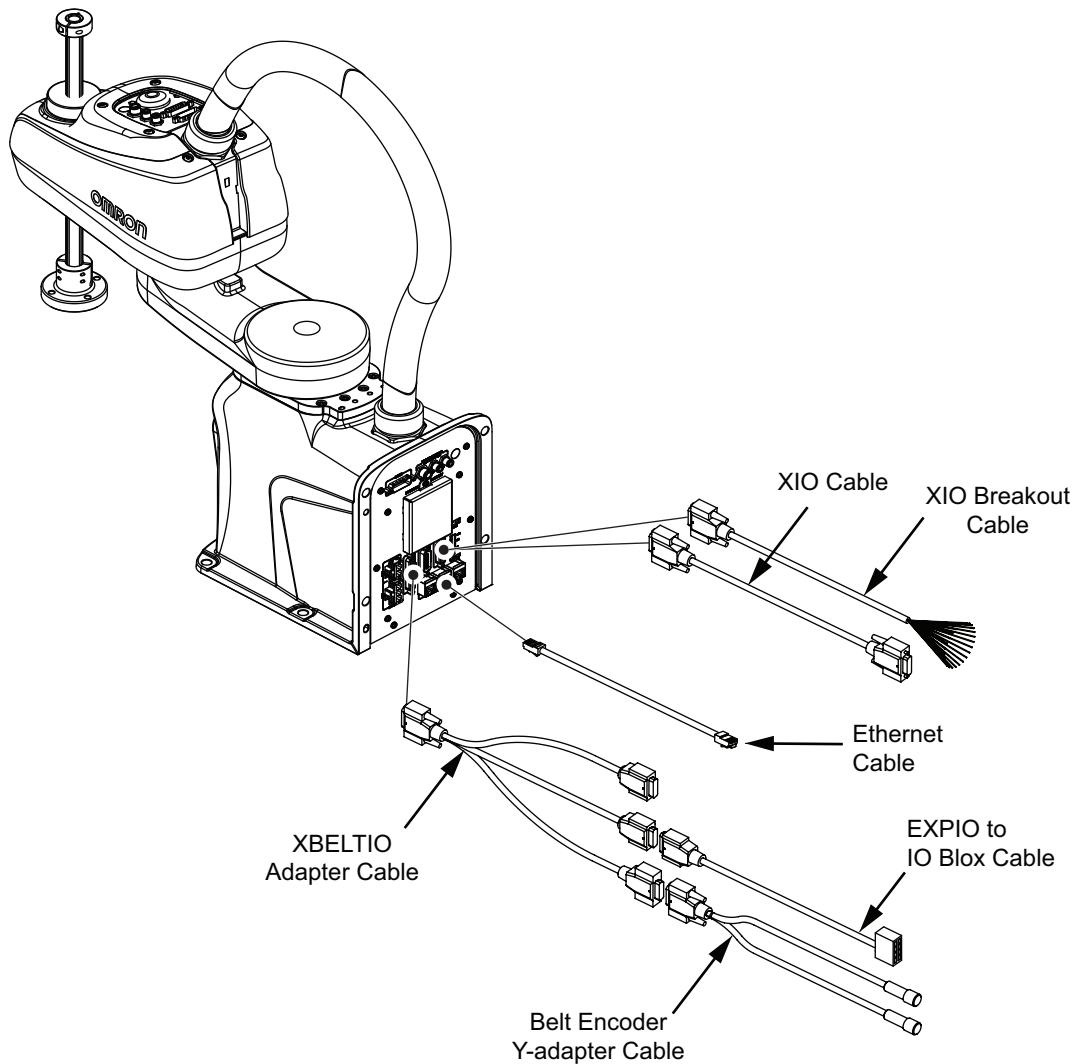

## PROFINET Connections

The following figure shows typical connections with a PROFINET controller. This is a typical connection method, but due to the presence of an internal switch, other configurations are possible.



### Precautions for Safe Use

Fieldbus communications are not secure. Additional measures must be taken if compliance with security standards is required.



### Additional Information

- A star configuration is the only topology supported for connecting multiple robots to a PROFINET network.
- PROFINET functionality is not enabled by default. Enabling the PROFINET fieldbus automatically configures and activates the robot's network ports for that specific fieldbus communication. By default, all ports are set for Ethernet communication when no fieldbus is active. Refer to *Automation Control Environment (ACE) Version 4 User's Manual (Cat. No. I633)* and *Industrial Robot Fieldbus Configuration User's Guide (Cat. No. M130)* for more information about enabling PROFINET communications.

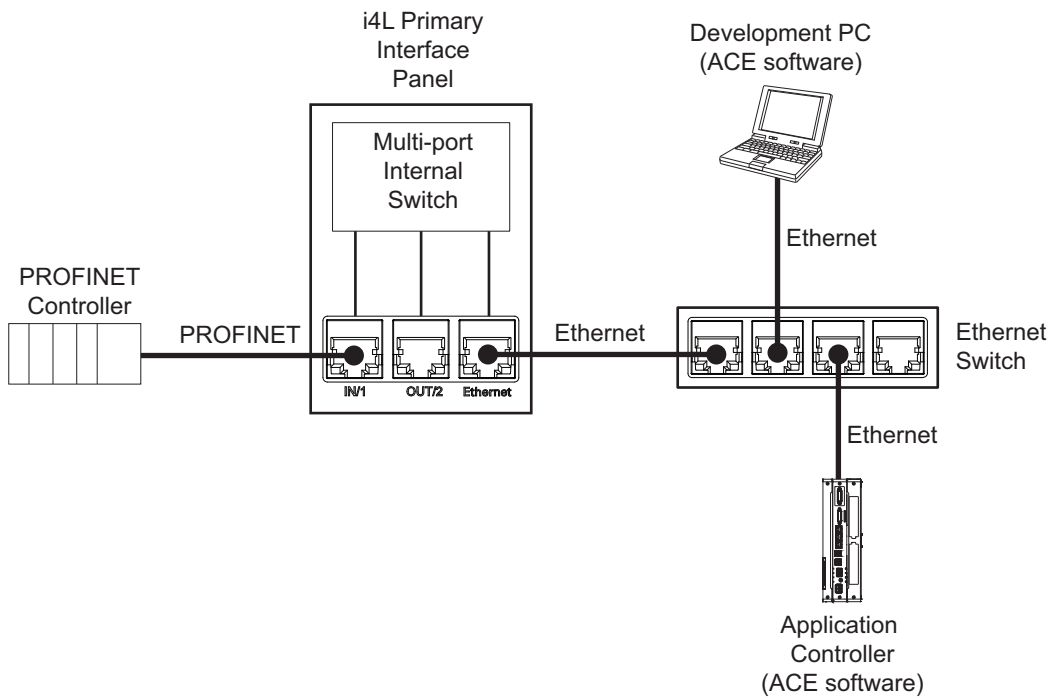

### 3-6-2 System Cable Installation Procedure

The following procedure provides details about system cable installation.

The robot must be mounted before following the steps below. Refer to *3-2 Mounting the Robot* on page 3-5 for more information.

- 1** Connect the XSYSTEM cable to the Primary Interface Panel XSYSTEM connector and route the XFP, XUSR, and XMCP connectors to their appropriate locations.
- 2** Connect any digital I/O to the XIO and TIO connectors.  
Refer to *3-7 Connecting Digital I/O* on page 3-29 for more information.
- 3** Connect external equipment such as the Front Panel and Teach Pendant to the XSYSTEM cable XFP and XMCP connectors.  
Refer to *3-6-1 System Cable Overview* on page 3-24 for more information.
- 4** Connect all user-supplied safety equipment to the XUSR connector on the XSYSTEM cable.  
Refer to *3-8 Installing Safety Equipment* on page 3-37 for more information.
- 5** If applicable, connect devices to the XBELTIO connector and the USER connectors.  
Refer to *Optional Connections* on page 3-26 for more information.

## 3-7 Connecting Digital I/O

The following sections describe the various methods to connect digital I/O to the robot.

### 3-7-1 XIO Connector Signals and Wiring

The XIO connector on the Primary Interface Panel provides access to 12 built-in digital inputs and 8 built-in digital outputs.

The XIO connector pin assignments are provided in the table below.



#### Additional Information

Refer to the following sections for more information.

- Refer to *2-3-2 XIO and TIO Connector I/O Specifications* on page 2-15 for electrical specifications.
- Refer to *2-5-5 Connector and Port Specifications* on page 2-19 for connector specifications.
- Refer to *A-5 I/O Signal Numbering* on page A-10 for all V+ signal number assignments.

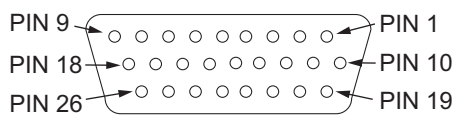

Pin Number	Designation	Signal Bank <sup>*1</sup>
1	Ground	---
2	24 VDC	---
3	Common 1	1
4	Input 1.1	
5	Input 2.1	
6	Input 3.1	
7	Input 4.1	
8	Input 5.1	
9	Input 6.1	
10	Ground	---
11	24 VDC	---
12	Common 2	2
13	Input 1.2	
14	Input 2.2	
15	Input 3.2	
16	Input 4.2	
17	Input 5.2	
18	Input 6.2	

Pin Number	Designation	Signal Bank*1
19	Output 1	--
20	Output 2	
21	Output 3	
22	Output 4	
23	Output 5	
24	Output 6	
25	Output 7	
26	Output 8	

\*1. Only applies when using an XIO Termination Block.

## XIO Internal Circuits

Use the following information to understand the XIO internal circuits.

### ● XIO Input Signals

The twelve inputs are arranged in two banks of six. Each bank is electrically isolated from the other bank. Each input is optically isolated. The six inputs within each bank share a common source / sink line.

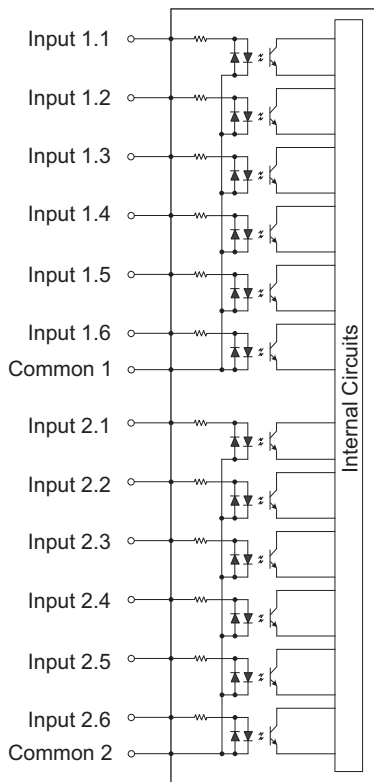

### ● XIO Output Signals

The eight outputs share a common, sourcing driver integrated circuit. The driver is designed to supply a load with one side connected to ground. Each channel is capable of switching up to 0.7 A of current. This driver has over-temperature protection, shorted load protection, and is current limiting. The driver draws power from the 24 VDC Control Power supplied to the robot through a self-resetting polyfuse.



**Precautions for Safe Use**

Output 8 can be assigned to indicate the robot's High Power state. When High Power is enabled, this output will turn ON. When High Power is not enabled, this output will be OFF. This is not a safety-rated means of indicating a High Power state and should only be used for monitoring the robot status. Use the ACE Software to make this configuration if needed.



**Precautions for Correct Use**

Use surge suppression when switching inductive loads such as relays to prevent damage to the output circuits.



**Additional Information**

If there is an output short or other over-current condition, the affected output of the driver integrated circuit turns OFF until the condition is removed.

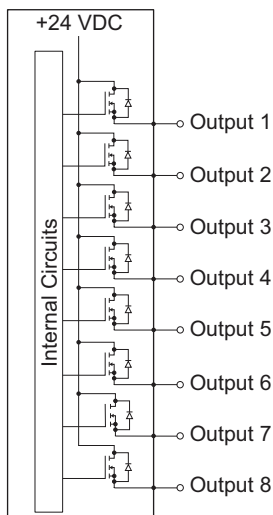

**XIO Breakout Cable Pinouts**

Use the following diagrams for XIO Breakout cable pinout information.

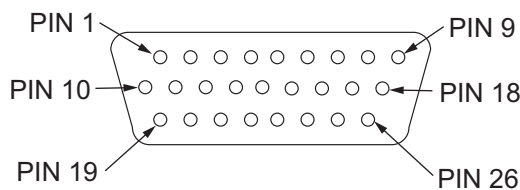

Pin Number	Signal	Wire Color
1	GND	White
2	24 VDC	White / Black
3	Common 1	Red
4	Input 1.1	Red / Black
5	Input 2.1	Yellow

Pin Number	Signal	Wire Color
6	Input 3.1	Yellow / Black
7	Input 4.1	Green
8	Input 5.1	Green / Black
9	Input 6.1	Blue
10	GND	Blue / White
11	24 VDC	Brown
12	Common 2	Brown / White
13	Input 1.2	Orange
14	Input 2.2	Orange / Black
15	Input 3.2	Gray
16	Input 4.2	Gray / Black
17	Input 5.2	Violet
18	Input 6.2	Violet / White
19	Output 1	Pink
20	Output 2	Pink / Black
21	Output 3	Light blue
22	Output 4	Light blue / Black
23	Output 5	Light green
24	Output 6	Light green / Black
25	Output 7	White / Red
26	Output 8	White / Blue
Shell	Shield	

## XIO Termination Block

An XIO termination block can be connected directly to the XIO connector to provide simple wiring and access to the built-in I/O.



### Additional Information

Refer to the *Adept XIO Termination Block Installation Guide (00340-000)* for more information.

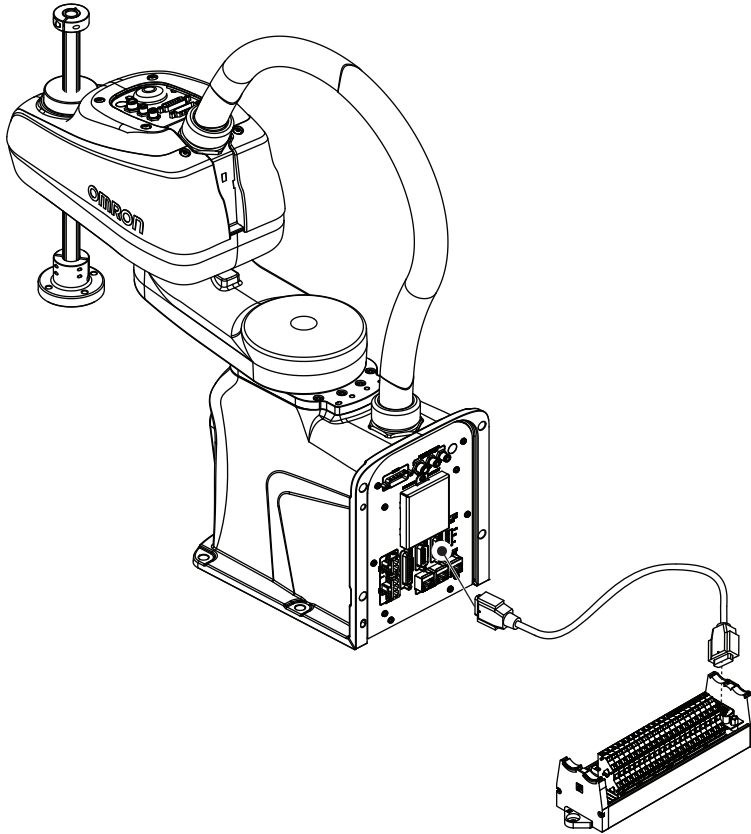

### 3-7-2 TIO Connector Signals and Wiring

The TIO connector on the Secondary Interface Panel provides access to built-in digital I/O (5 inputs and 4 outputs).

The TIO connector pin assignments and signal numbers are provided below.



#### Additional Information

- Refer to 2-3-2 *XIO and TIO Connector I/O Specifications* on page 2-15 for electrical specifications.
- Refer to 2-5-5 *Connector and Port Specifications* on page 2-19 for connector specifications.

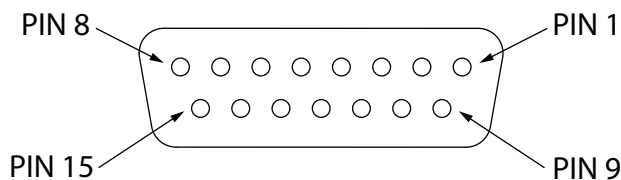

Pin Number	Designation	V+ Signal Number <sup>*1</sup>
1	Common	—
2	Input 5	1021
3	Input 2	1018
4	Input 4	1020
5	24 VDC	—
6	Output 3	19
7	Output 4	20

Pin Number	Designation	V+ Signal Number*1
8	Ground	--
9	Input 1	1017
10	Input 3	1019
11	Ground	--
12	Output 1	17
13	Output 2	18
14	Ground	--
15		

\*1. Systems using firmware version 2.6 use the following V+ signal numbers.

- Inputs: 1033 to 1037
- Outputs: 33 to 36

## TIO Internal Circuits

Use the following diagram to understand the TIO internal circuits.

### ● TIO Input Signals

The 5 input channels are optically isolated and share a common source / sink line.

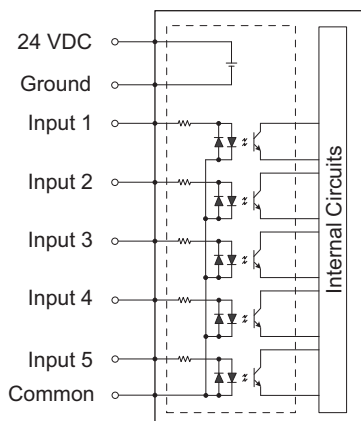

### ● TIO Output Signals

The 4 outputs share a common, sourcing driver integrated circuit. The driver is designed to supply a load with one side connected to ground. Each channel is capable of switching up to 0.7 A of current. This driver has over-temperature protection, shorted load protection, and is current limiting. The driver draws power from the primary 24 VDC input to the robot through a self-resetting poly-fuse.



#### Precautions for Correct Use

Use surge suppression when switching inductive loads such as relays to prevent damage to the output circuits.



#### Additional Information

If there is an output short or other over-current condition, the affected output of the driver integrated circuit turns OFF until the condition is removed.

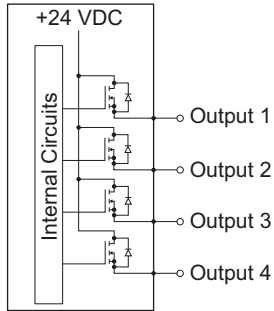

## Pneumatic Valve Kit Signals

Use the following signal designations to control solenoids on the pneumatic valve kit.

- Output 1: SNLD 1
- Output 2: SNLD 2
- Output 3: SNLD 3



### Additional Information

Valve types are SMC type VQZ1121-5MO1-C4-Q.

## 3-7-3 IO Blox Connections

IO Blox units can be connected to the XBELTIO connector using the XBELTIO adapter cable. Up to 4 IO Blox units can be connected as shown below.



### Additional Information





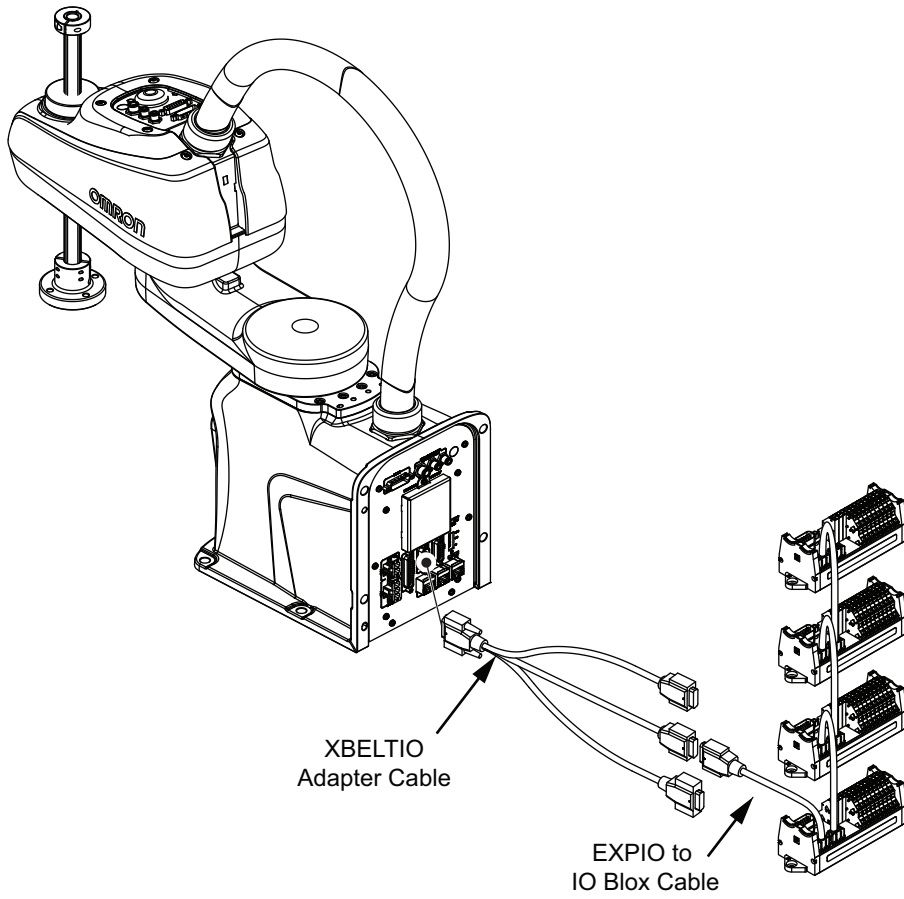

Refer to the following areas for more information.

- *A-5 I/O Signal Numbering* on page A-10
- *Omron Adept IO Blox User's Guide (04638-000)*



## 3-8 Installing Safety Equipment

The user-supplied safety equipment connects to the system through the XMCP, XUSR and XFP connectors on the XSYSTEM cable. Refer to the following sections for safety equipment connection details.

 <b>DANGER</b>	
<ul style="list-style-type: none"> <li>• The robot system must be installed with user-supplied interlock barriers. The interlocked barriers must open the E-Stop circuit in the event of personnel attempting to enter the work cell when High Power is enabled. Failure to install suitable guarding or interlocks could result in injury or death. We strictly prohibit installation, commissioning, or operation of any robot without adequate safeguards. These must be compliant with applicable local and national standards.</li> <li>• The placement of safety controls shall avoid requiring a person to enter a hazardous area to actuate them.</li> <li>• Controls shall be located outside of the safeguarded space, except for certain controls such as emergency stops or a teach pendant, where based on a risk assessment they may be located within the safeguarded space.</li> </ul>	
 <b>WARNING</b>	
<p>Before starting the operation of equipment, always confirm that the safety equipment of the robot works properly. If a malfunction of the safety equipment is detected, follow the troubleshooting procedure.</p>	
 <b>CAUTION</b>	
<p>The design and installation of the complete system must comply with the safety standards and regulations in the country of use. The integrators of the robot should understand the safety laws and regulations in their countries and prevent major hazards from occurring in the complete system.</p>	



### Additional Information

Refer to the *Robot Safety Guide (Cat. No. I590)* for more information.

### 3-8-1 Installing the Front Panel

Use the dimensions below to install the Front Panel in a suitable location outside of the robot's workspace where it can be easily accessed for emergency stops.

The length of the XSYSTEM cable (1.8 m) and the length of the Front Panel extension cable (3 m) should also be considered when choosing an installation location.

 <b>DANGER</b>	
<p>Any High Power push-buttons must be installed outside of the robot's workspace.</p>	

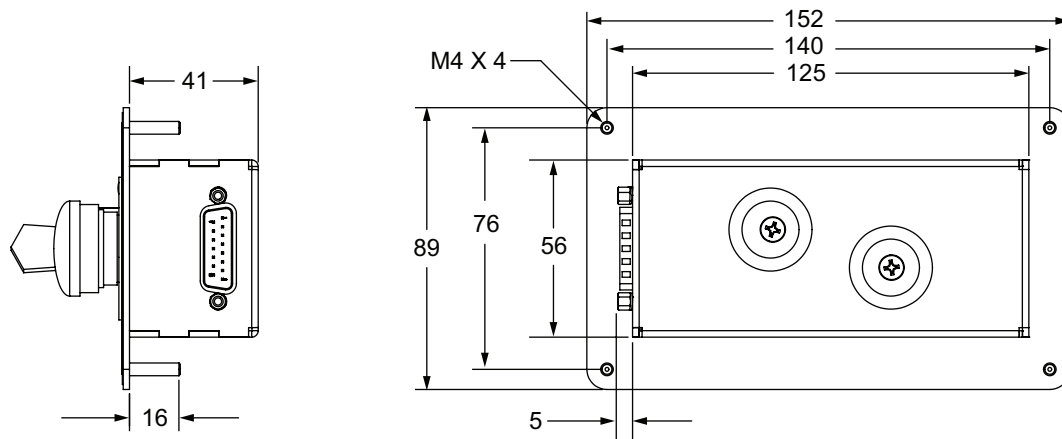

## Front Panel Connections

The Front Panel is connected directly to the XFP connector on the XSYSTEM cable with the 3 m extension cable supplied with the Front Panel.



### Precautions for Safe Use

Do not connect user-supplied Manual / Automatic contacts or other control signals in parallel with the Front Panel switch contact. This would violate the Single Point of Control principle and might allow Automatic mode to be selected while an operator is in the cell.

- The part number of the extension cable is 10356-10500.
- The length of the extension cable is 3 m.



### Additional Information

Refer to *XFP Connections* on page 3-40 for more information.

## 3-8-2 Safety Circuits

The XSYSTEM cable provides connections for all emergency stop circuits. All emergency stop circuits are dual-channel and voltage-free. These voltage-free contacts are provided by a redundant, cyclically-checked, positive-drive, safety relay circuit for Category 3 PL-e per ISO 13849 operation.

The XUSR connector provides access to the following safety circuits.

- Dual channel emergency stop inputs.
- Dual channel emergency stop status outputs.
- Dual channel Automatic mode emergency stop inputs.
- Dual channel Automatic / Manual mode status outputs.

The XFP connector provides access to the following safety circuits that are typically used with the Front Panel.

- Dual channel emergency stop inputs.
- Dual channel Automatic / Manual mode selection inputs.
- High power indicator output.
- High power enable input.
- Control power indicator output.

The XMCP connector provides access to the following safety circuits that are used with a connected Teach Pendant.

- Dual channel E-stop button inputs.
- Dual channel pendant enable switch inputs.

Use the diagram below to understand safety circuits.

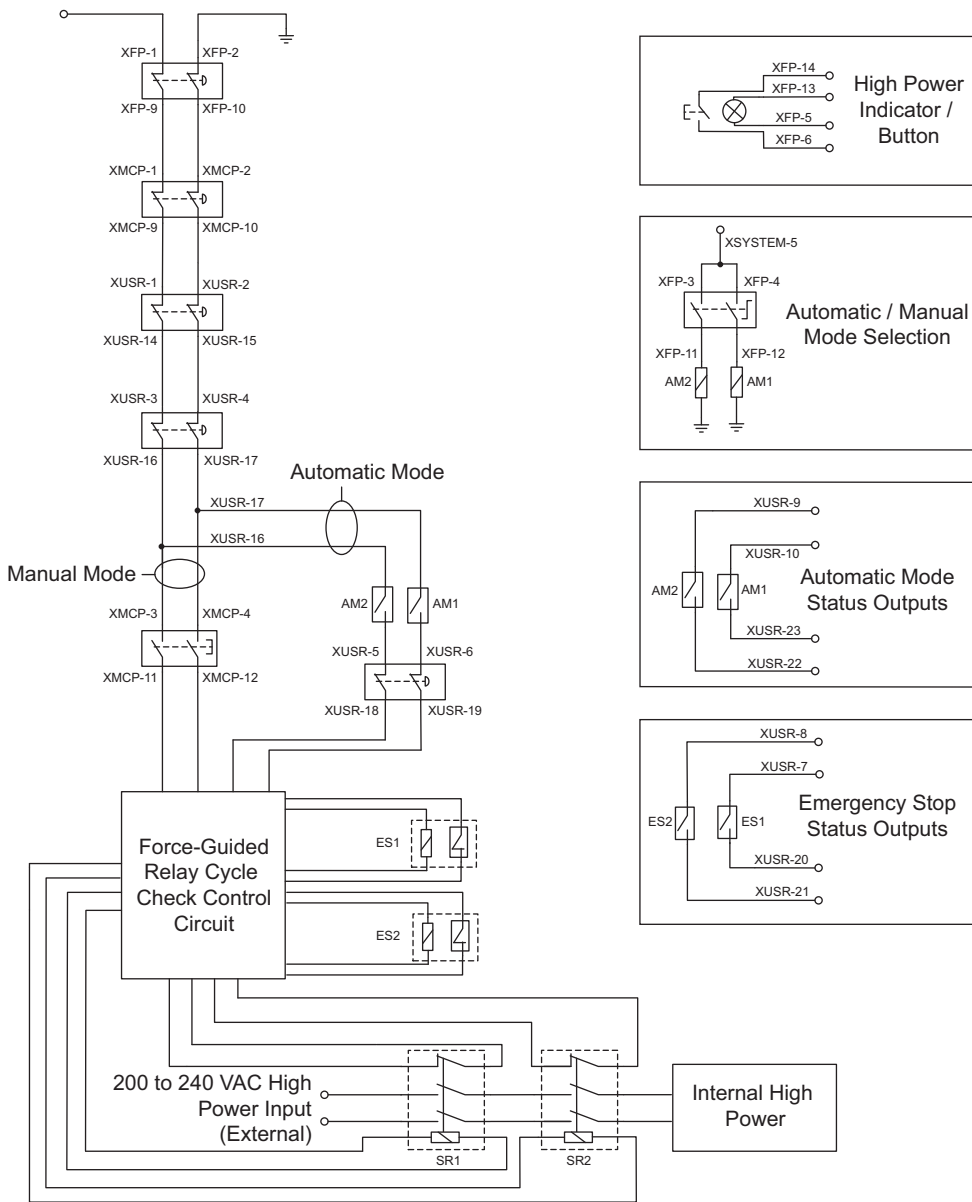

## XUSR Connections

Use the information in the following table to understand the signals provided on the XUSR connector.

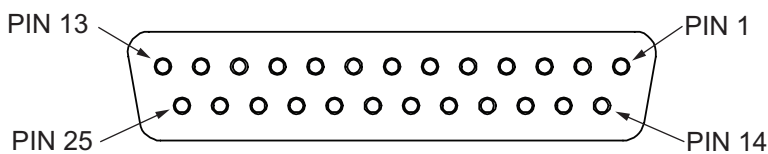

Pins	Description	Additional Information
1, 14	Emergency stop status input channel 1	Typically connected to normally closed contacts on user-supplied safety devices such as E-stop buttons, safety switches, or safety relays.
2, 15	Emergency stop status input channel 2	
3, 16 4, 17	Line emergency stop inputs	Normally closed contacts on user-supplied safety devices typically used for other robot or line emergency stop interconnection. This does not affect emergency stop status output channels 1 and 2 on pins 7, 20 and pins 8, 21.
5, 18	Automatic mode emergency stop status input channel 1	Typically connected to normally closed contacts on user-supplied safety devices such as E-stop buttons, safety switches, or safety relays.
6, 19	Automatic mode emergency stop status input channel 2	
7, 20	Emergency stop status output channel 1	Internal contacts are closed when Front Panel, Teach Pendant, and emergency stop status inputs channels 1 and 2 are not enabled / activated.
8, 21	Emergency stop status output channel 2	
9, 22	Automatic mode status channel 1	Internal contacts are closed when the robot is in automatic mode.
10, 23	Automatic mode status channel 2	
11, 12, 13, 24, 25	Reserved for future use.	

#### ● XUSR Jumper Plug

The XUSR jumper plug is provided for safety equipment troubleshooting only.

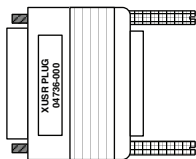

## ! WARNING

Never run a robot system with all jumpers installed. This would leave the system with no E-Stops.



#### Additional Information

The XUSR jumper plug is supplied with the robot.  
The part number for the XUSR jumper plug is 04736-000.

## XFP Connections

Use the information in the following table to understand the signals provided on the XFP connector.

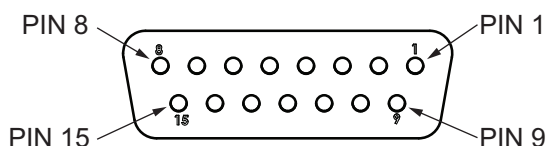



### Additional Information

Refer to *Front Panel Connections* on page 3-38 for more information.

Pins	Description	Additional Information
1, 9	Front panel E-stop button channel 1 input	Typically connected to normally closed contacts on the E-stop button used with the Front Panel.
2, 10	Front panel E-stop button channel 2 input	
3, 11	Automatic / Manual mode selection channel 1 input	Typically connected to the selector switch used with the front panel. An open circuit selects Manual mode. A closed circuit selects Automatic mode.
4, 12	Automatic / Manual mode selection channel 2 input	
5, 13	System-supplied 5 VDC output (pin 5) and common (pin 13) for High Power indicator lamp.	If lamp is user-supplied, it must draw between 10 mA to 500 mA to satisfy the internal High Power lamp monitoring function.* <sup>1</sup>
6, 14	High Power ON / OFF	Typically connected to a momentary push-button that enables High Power when all safety circuits are satisfied.
7, 15	System-supplied 5 VDC output (pin 7) and common (pin 15) for Control Power indicator.	If indicator is user-supplied, the recommended load is between 20 to 500 mA.
8	Reserved for future use	

- \*1. Lamps that illuminate with a low current (10 mA to 25 mA) may appear dim when the High Power is OFF due to leakage current. If this occurs, add additional resistance to ensure the lamp is OFF when High Power is not enabled.

### ● XFP Wiring Diagram

Use the following diagram to understand XFP electrical connections.



## WARNING

If you supply your own Front Panel E-Stop, its design must comply with the requirements of IEC 60204-1 and ISO 13849. The E-Stop's push button must comply with ISO 13850 (Clause 5.5.2).





### Precautions for Correct Use

Do not disable or bypass the High Power button. This will violate IEC 60204-1.

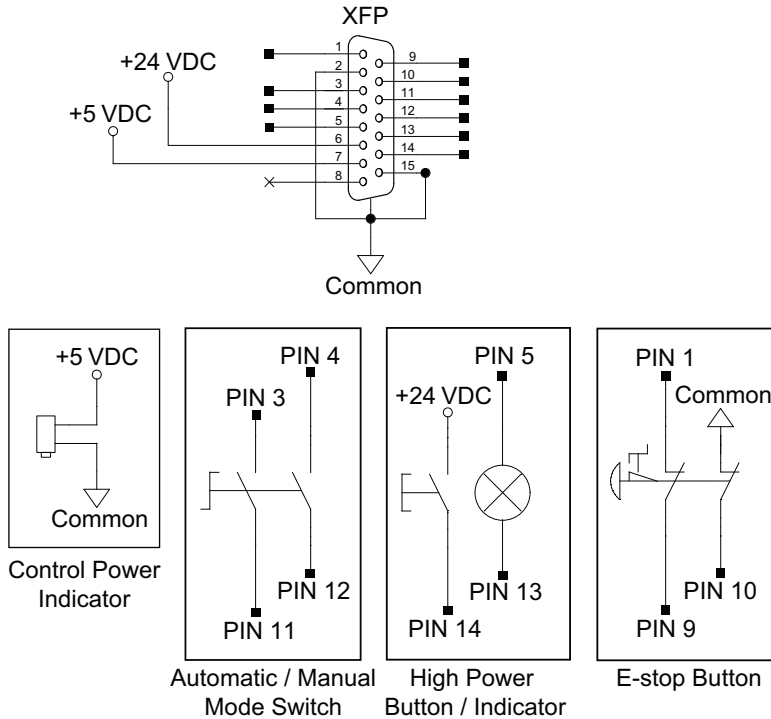

● **XFP Jumper Plug**

The XFP jumper plug is provided for safety equipment troubleshooting.

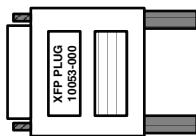

## ⚠ WARNING

Never run a robot system with all jumpers installed. This would leave the system with no E-Stops.



**Additional Information**

- The XFP jumper plug is supplied with the robot.
- The part number for the XFP jumper plug is 10053-000.

## XMCP Connections

Use the information in the following table to understand the signals provided on the XMCP connector.

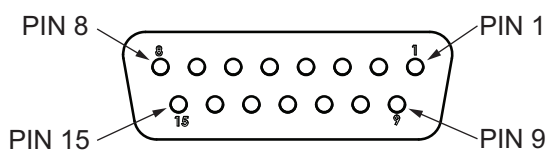



### Additional Information

Refer to the *T20 Pendant User's Manual (Cat. No. I601)* for additional information.



### Precautions for Correct Use

If Teach Pendant cabling is installed, the jumper plug or the Teach Pendant must be connected to satisfy safety circuits and allow High Power to be enabled.

Pins	Description	Additional Information
1, 9	Pendant E-stop button channel 1	Connected to the pendant's integrated E-stop button.
2, 10	Pendant E-stop button channel 2	
3, 11	Pendant enable switch channel 1	Connected to the pendant's integrated enable switch.
4, 12	Pendant enable switch channel 2	
6	24 VDC pendant supply	
7	Serial communications TXD	Pendant serial communications transmit signal.
8	Serial communications RXD	Pendant serial communications receive signal.
13	Serial communications GND	Pendant serial communications ground signal.
Shield	Ground shield	
5, 14, 15	Reserved for future use.	

### ● XMCP Jumper Plug

The XMCP jumper plug is used when there is no T20 pendant adapter cable connected.

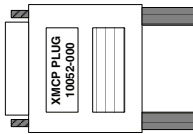

## ! WARNING

Never run a robot system with all jumpers installed. This would leave the system with no E-Stops.



### Additional Information

- The XMCP jumper plug is supplied with the robot.
- The part number for the XMCP jumper plug is 10052-000.

### ● Teach Pendant Jumper Plug

The Teach Pendant jumper plug is provided to allow the system to operate when Teach Pendant cabling is installed, but the Teach Pendant is not connected. This plugs into the Teach Pendant adapter cable when the pendant is not in use.

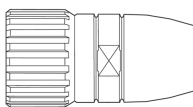



### **Additional Information**

---

- The jumper plug is supplied with the Teach Pendant kit.
  - The part number for the Teach Pendant jumper plug is 10048-000.
-

## 3-9 Setting the EtherCAT Node ID

The EtherCAT node ID / address can be set with two methods as described below.

- Use Hardware Switches on the Robot.

Use the hardware switches on the robot interface panel to set an explicit EtherCAT node ID for the robot. Refer to *3-9-1 EtherCAT Node ID Setting Example* on page 3-45 for more information.

Switch positions are only evaluated during the power-up procedure after 24 VDC Control Power is applied. Changing switch positions while the robot Control Power is ON will have no effect until the power is cycled.

Use Sysmac Studio Automation software (for OMRON EtherCAT MainDevices) or the software application for your MainDevice to verify the EtherCAT node ID setting after adjusting the switches.

- Use Sysmac Studio Automation software (for OMRON EtherCAT MainDevices) or the software application for your MainDevice.

When using Sysmac Studio or other MainDevice software applications to set the EtherCAT node ID, ensure the switches are set to the default 0 positions. If the switches are set to a non-zero value, the switch positions will dictate the EtherCAT node ID and software adjustment of this value is not possible. Switches should be in the following positions when using software to set the EtherCAT node ID.

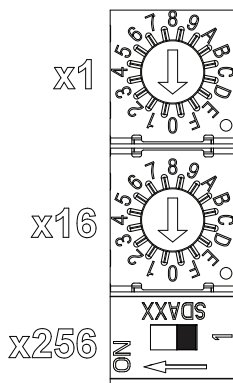

When the EtherCAT node ID is set with Sysmac Studio or other MainDevice software applications, it is retained in non-volatile memory and will persist after subsequent power cycles.



### Additional Information

Refer to *Sysmac Studio Version 1 Operation Manual (Cat. No. W504)* for more information about setting the EtherCAT node ID with software.

### 3-9-1 EtherCAT Node ID Setting Example

In the following example, an EtherCAT node ID of 196 is used to demonstrate how to make the switch settings.

- 1** Begin by converting the desired node ID into a hexadecimal format. In this example, 196 is converted to 0x0C4.
- 2** Set the x256 dip switch to the OFF position.
- 3** Set the x16 rotary switch to position C.

- 4** Set the x1 rotary switch to position 4.
- 5** Confirm that the switches are in the following positions.

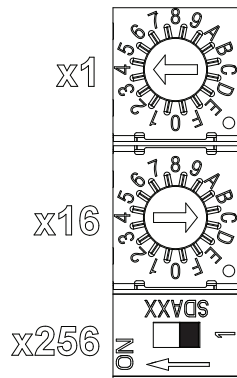

- 6** Apply or cycle Control Power to implement the new node ID setting.
- 7** Confirm the correct EtherCAT node ID of 196 with Sysmac Studio Automation software (for OMRON EtherCAT MainDevices) or the software application for your MainDevice.

## 3-10 Supplying Power and Ground

The robot requires separate 24 VDC and 48 VDC power supplies. The 24 VDC supply provides Control Power and the 48 VDC supply provides power to the internal servo amplifiers.

A lockout tagout main disconnect device must be installed on the AC supply to the 24 VDC and 48 VDC power supplies. These devices are user-supplied. Disconnect devices shall be accessible and conveniently located to facilitate application of lockout devices during service and maintenance.

Use the information below to make all power supply connections to the robot.



### Additional Information

Refer to *2-3-1 Power Supply Specifications* on page 2-15 for information about power supply requirements and other wiring details.

### 3-10-1 Grounding the System

The system should be grounded properly to avoid transient voltages or other electrical noise. There are two primary ground points on the system as described below.

- Earth ground
- Chassis ground



### Precautions for Safe Use

The Joint 3 quill and the tool flange are not grounded to protective earth. If hazardous voltages are present at any user-supplied robot-mounted equipment or tooling, you must install a ground connection from that equipment or tooling to the ground point on the robot base.

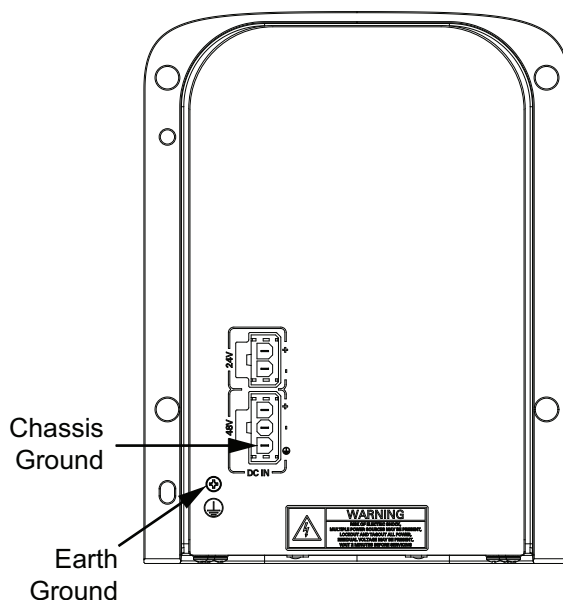

### 3-10-2 Power Connections

Use the following information to understand the recommended power connections.

Circuit protection is not shown in the diagram below, but must be included.



### Additional Information

Dashed lines in the figure below denote optional chassis ground connections that are recommended if available on the power supply.

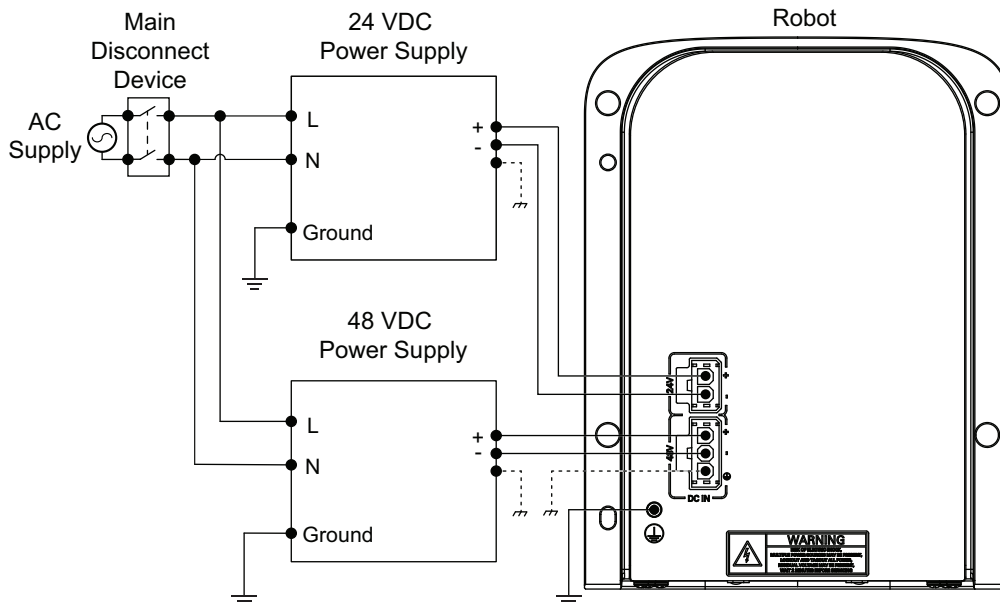

## 24 VDC Connections

The 24 VDC Control Power connector is located on the Primary Interface Panel. A 24 VDC power supply mating connector is provided with the robot.



### Additional Information

- Refer to *3-4-5 Control Power Kit Connections* on page 3-20 for more information.

Use the illustration below to understand the polarity of the mating connector.

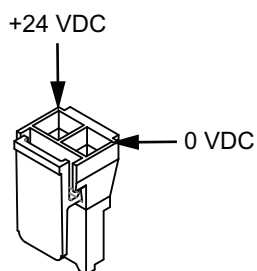

## 48 VDC Connections

The 48 VDC High Power connector is located on the Primary Interface Panel. A 48 VDC power supply mating connector is provided with the robot.



### Additional Information

- Refer to *3-4-6 High Power Kit Connections* on page 3-20 for more information.

Use the illustration below to understand the polarity and ground terminals of the mating connector.

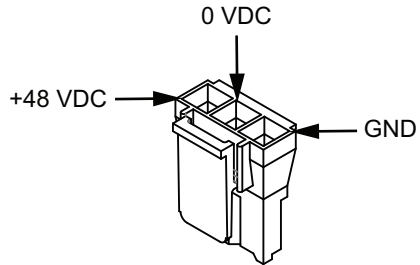

## 3-11 Verifying Installation

If any modifications have been made to the robot during installation or other actions, make the following checks before operation.

### 3-11-1 Mechanical Checks

Make the following mechanical checks after any hardware adjustments have been made to the system.

- Check that the robot mounting surface is secure and adequate.
- Check all mounting bolts and other fasteners for proper torque.
- Check the tool flange and end-of-arm tooling for correct installation and grounding (when necessary).
- Check any equipment that is mounted to the robot to make sure it is securely fastened.

### 3-11-2 System Cable Checks

Make the following system cable checks after any adjustments have been made to cable connections.

- Check all cables and connectors to ensure that they are securely fastened and free of damage.
- Check the system ground and power supply connections to make sure that they are connected properly.
- Check that all cables are adequately supported and not strained near the connectors.

### 3-11-3 Safety Equipment Checks

Make the following checks to all user-supplied safety equipment to ensure emergency stops are properly installed and other safety systems are functioning correctly.

When checking safety equipment, the following prerequisites are necessary.

- ACE software must be installed and available.
- The Front Panel operating mode switch must be in the Automatic position.
- All emergency stop devices must be able to be activated and deactivated easily.

Use the following utilities in the ACE software to confirm safety operations controlled by robot software.

Safety Setting Function	Description
Configure Teach Restrict	<p>The objective of the Teach Restrict feature is to comply with safety regulations which require that the speed be limited while the robot is in Manual mode.</p> <p>This is hardware-based safety functionality to prevent rapid robot motion in Manual mode even in the unexpected event of software error attempting to move a robot faster than allowed. While jogging the robot in Manual mode, if any joint exceeds its configured speed limit, the system will disable High Power.</p> <p>Configuration will set predetermined speed limits for each robot motor.</p> <p>Verification will verify that Teach Restrict operations are functioning properly in Automatic and Manual modes.</p>
Verify Teach Restrict Auto	
Verify Teach Restrict Manual	

Safety Setting Function	Description
Configure E-stop Hardware Delay	The objective of the ESTOP hardware delay feature is to comply with safety regulations which require the robot to have the capability of disabling High Power without software intervention in an emergency stop situation. Configuration will set the delay for the emergency stop timer circuit. Verification will verify that High Power is disabled without software intervention in an emergency stop situation.
Verify E-stop Hardware Delay	



#### Additional Information

Refer to the *Automation Control Environment (ACE) Version 4 User's Manual (Cat. No. I633)* for more information about using the Safety Setting functions.

## Emergency Stop Check Procedure

Use the following procedure to check for correct emergency stop operation.

- 1** If a pendant is present in the system, connect it to the XSYSTEM cable.
- 2** Prepare all emergency stop devices for enabling the robot High Power.
- 3** Enable the robot High Power with one of the methods described in *4-4-1 Robot High Power Operations* on page 4-7.
- 4** Confirm that robot High Power is enabled using the High Power indicator. If robot High Power is not enabled, refer to *Section 5 Troubleshooting* on page 5-1 for more information.
- 5** Activate each and every emergency stop device connected to the system to check that High Power is disabled for all safety equipment. This includes pendant safety devices, Front Panel safety devices, and any other safety equipment wired to the XUSR connector. After one safety device check is made, deactivate it, enable High Power again, and make a check for the next safety device. Repeat 2 to 5 until all safety device functionality is confirmed to be working properly.

## High Power Indicator Check

When High Power is enabled, an amber indicator lamp must turn ON to alert personnel that the robot is capable of motion to satisfy safety requirements.

### ● High Power Indicator Check Procedure

Use the following procedure to verify that the High Power indicator is working correctly.

- 1** Apply Control Power to the robot and disable High Power.
- 2** Make a High Power request using one of the methods described in *High Power Control Methods* on page 4-8.

- 3** Check that the High Power indicator flashes. After the High Power request is made and the indicator is checked, the procedure is complete.

### 3-11-4 Switch Position Checks

Switch positions on the Primary Interface Panel are reserved for future use and do not impact functionality of the robot.

# 4

## Operation

This section provides information necessary to operate the robot.

---

<b>4-1</b>	<b>Connecting to the Robot</b> .....	<b>4-2</b>
4-1-1	Initial Connection Procedure .....	4-2
<b>4-2</b>	<b>Payload and Acceleration Considerations</b> .....	<b>4-4</b>
<b>4-3</b>	<b>Robot Control Modes</b> .....	<b>4-5</b>
4-3-1	Manual Mode.....	4-5
4-3-2	Automatic Mode .....	4-5
<b>4-4</b>	<b>Enabling and Disabling the Robot</b> .....	<b>4-7</b>
4-4-1	Robot High Power Operations.....	4-7
<b>4-5</b>	<b>LED Indicators</b> .....	<b>4-9</b>
4-5-1	Visual Status LED Indicator.....	4-9
4-5-2	PROFINET Device Identification LED Indicators .....	4-9
4-5-3	Front Panel LED Indicators .....	4-10
<b>4-6</b>	<b>Brake Operation</b> .....	<b>4-11</b>
4-6-1	Built-in Brake Release Button .....	4-11
4-6-2	Remote Brake Release .....	4-12
<b>4-7</b>	<b>Manually Jogging the Robot</b> .....	<b>4-13</b>
<b>4-8</b>	<b>Robot Positioning</b> .....	<b>4-14</b>
4-8-1	Joint Zero Position.....	4-14
4-8-2	Ready Position .....	4-14
4-8-3	Right-Left Arm Configurations .....	4-15
4-8-4	Collision Avoidance .....	4-15

## 4-1 Connecting to the Robot

Use the information in this section to establish a connection to the robot with the ACE software. Refer to the *Automated Control Environment (ACE) Version 4 User's Manual (Cat. No. I633)* for more information.

The following conditions must be present before attempting to connect to the robot.

- ACE software must be installed on the PC.
- The robot must be completely installed with all safety equipment connected and verified.
- 24 VDC Control Power must be supplied to the robot.
- An Ethernet network must be available and connected to the robot and the PC.

### 4-1-1 Initial Connection Procedure

Use the procedure below to detect and connect to a robot controller.

#### DANGER

An i4L robot can cause serious injury or death, or damage to itself and other equipment, if the following safety precautions are not observed:

- All personnel who install, operate, teach, program, or maintain the system must read this guide, read the *Robot Safety Guide (Cat. No. I590)*, and complete a training course for their responsibilities in regard to the robot.
- All personnel who design the robot system must read this guide, read the *Robot Safety Guide (Cat. No. I590)*, and must comply with all local and national safety regulations for the location in which the robot is installed.
- The robot system must not be used for purposes other than described in *1-1 Intended Use* on page 1-2. Contact your local OMRON support if you are not sure of the suitability for your application.
- The user is responsible for providing safety barriers around the robot to prevent anyone from accidentally coming into contact with the robot when it is in motion.
- Power to the robot and its power supply must be locked out and tagged out before any maintenance is performed.
- When the robot or robotic equipment is not investigated in conjunction with a system work cell, the instructions shall call attention to the following: the interlocked portion of barrier shall be installed, applied, and maintained so that it has the capability of being easily unlocked from the inside of the safeguarded space, with or without power available, when the possibility of full body access exists.



#### WARNING

The instructions for operation, installation, and maintenance given in this document must be strictly observed.



- 1 After starting the ACE software, click the **Connect to Device** item. If the robot controller appears in the Detected Controller IP Address area, select it and click the **Connect** Button. This will initiate the online connection process. If no controller appears in this area, proceed to the next step.

- 2** To find a robot controller on the Ethernet network, click the **Detect and Configure Robotic Controller** Button. This will open the Controller IP Address Detection and Configuration Dialog Box.

In this area, a detected controller's properties can be modified to establish an online connection.

If a controller is detected but resides on a different LAN and does not have a gateway configured, an online connection is not possible until one of the following actions are taken.

- The detected controller's IP address and / or subnet is changed for compatibility with the PC's LAN connection. Select the detected controller and change the Desired Properties Address, Subnet, and Name accordingly.
- The PC's IP address and LAN connection are changed to be compatible with the controller's network settings. Adjust the PC's network adapter properties accordingly.



#### **Precautions for Correct Use**

---

If no controller(s) is detected, check the Ethernet network and cables and ensure that a network connection is available between the robot controller and the PC.

---

- 3** After the desired robot controller appears with the proper network settings, click the **Connect** Button to establish a connection and complete this procedure.

## 4-2 Payload and Acceleration Considerations

Careful considerations must be made when using high payloads, high accelerations, or a combination of both.

The PAYLOAD keyword can be used to specify the payload mass, inertia, and payload center of mass. Use this keyword to reduce settling time and motion path deviations for a specific payload. Refer to the *V+ Keyword Reference Manual (Cat. No. I672)* for more information.

Use the following chart to understand the limitations to acceleration and payload when making linear moves. Some linear moves are not achievable over all paths in the working envelope.



### Precautions for Correct Use

Operating the robot outside of the payload and speed constraints described in this document can damage or reduce the service life of the z-axis quill.

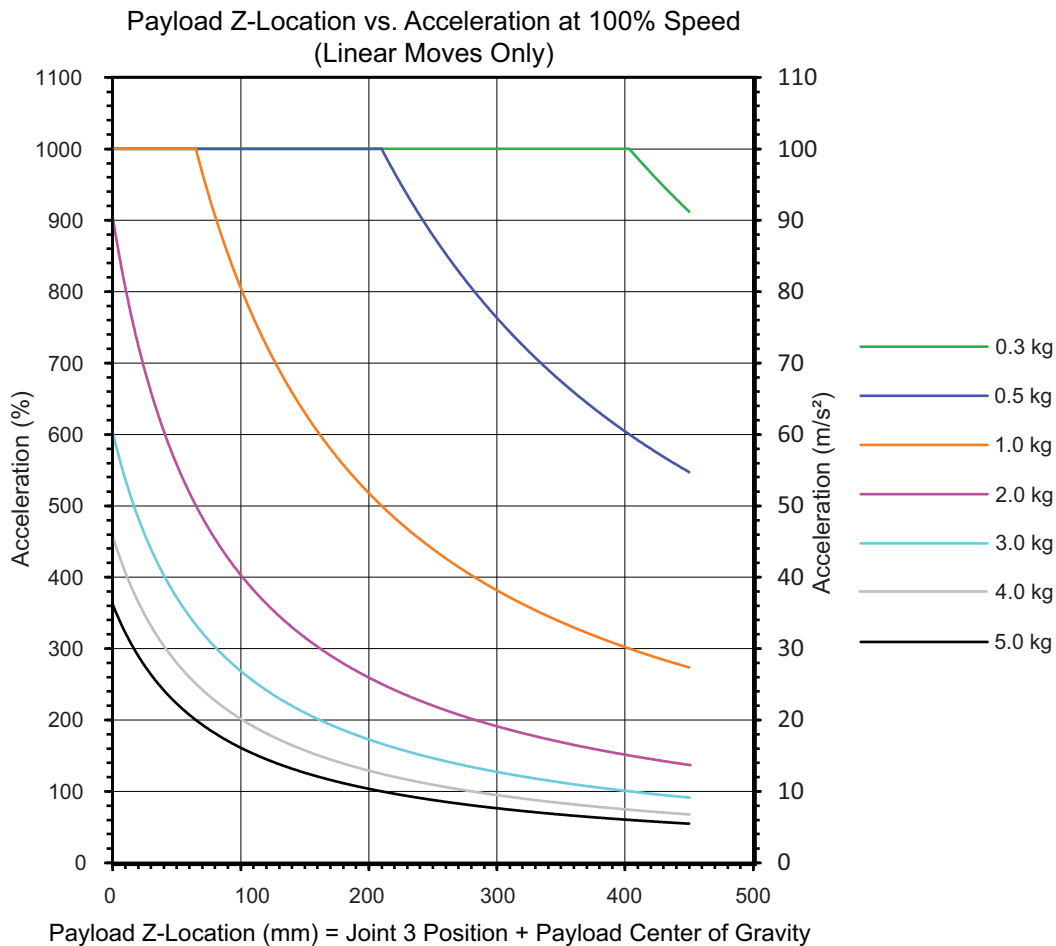

## 4-3 Robot Control Modes

The robot can operate in Automatic or Manual control modes. These modes are described in the following sections.

### 4-3-1 Manual Mode

Manual mode is typically used during functions of commissioning, position teaching, and other setup operations. In this mode, the robot will respond to the control signals issued by the connected pendant.

When the robot is placed in Manual mode, robot motion speed is limited to 250 mm/sec and servo torque is limited so an operator can safely work inside the cell. Programs can execute from the pendant in STEP mode.



#### Precautions for Safe Use

- After an operator places the robot in Manual mode using the Front Panel key switch, they should remove the key for safety purposes.
- During manual operation, ensure all persons are a safe distance away from the robot work envelope.



#### Additional Information

Refer to the *T20 Pendant User's Manual (Cat. No. I601)* for more information.

To place the robot in Manual mode, use the Front Panel key switch and rotate it to the left position as indicated below. Changing the robot control mode will automatically disable High Power.

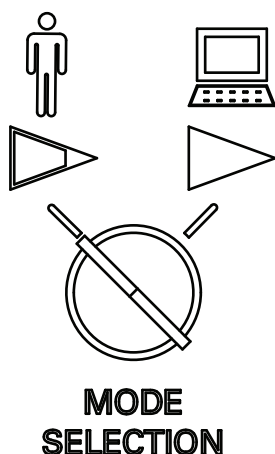

### 4-3-2 Automatic Mode

Automatic mode is used when the robot is operating under normal conditions.

When the robot is placed in Automatic mode, program execution will control the robot up to the maximum speed.

**Precautions for Safe Use**

Prior to placing the robot in Automatic Mode, all safeguards must be returned to their safe state.

To place the robot in Automatic mode, use the Front Panel key switch and rotate it to the right position as indicated below. Changing the robot control mode will automatically disable High Power.

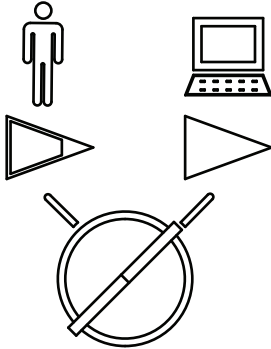
**MODE  
SELECTION****! WARNING**

In Automatic mode, the robot can move unexpectedly. Ensure all personnel remain clear of the cell when Automatic mode is enabled.



## 4-4 Enabling and Disabling the Robot

Enabling the robot energizes all robot servo motors with the 48 VDC power supply. This is also referred to as enabling High Power. When the robot is enabled, it is capable of moving.

Program execution and I/O control functions are still operational when High Power is disabled. However, ATTACH or other motion commands may return errors or delay program execution if High Power is disabled. Refer to the *V+ Keyword Reference Manual (Cat. No. I672)* for more information.

Disabling the robot de-energizes all robot servo motors.



### Additional Information

When High Power is enabled, the brake is automatically released. When High Power is disabled, the brake is automatically activated to prevent downward motion of the quill due to gravity.



### Precautions for Safe Use

- The LED indicator does not reflect the robot's High Power status. To see the robot's High Power status, use the Front Panel indicator or a user-supplied indicator connected to the XFP connector.
- High Power cannot be enabled unless all safety circuits are satisfied.

### 4-4-1 Robot High Power Operations

Robot High Power operations are described below.

#### High Power Safety Timeout

If the safety timeout function is enabled in the robot configuration, the High Power indicator on the Front Panel will flash for a specified amount of time after a High Power request is made. If the High Power button is not pressed within the specified amount of time, a safety timeout occurs and High Power is not applied.

The safety timeout function is enabled by default and has a duration set for 10 seconds. The safety timeout function configuration settings are accessed with the ACE Software. Refer to the *Automated Control Environment (ACE) Version 4 User's Manual (Cat. No. I633)* for more information.



### Precautions for Correct Use

If a Front Panel is not present, the High Power indicator and High Power button signals can be accessed with the XFP system cable connector. Refer to *XFP Connections* on page 3-40 for more information.

#### High Power and Faults

If a fault is present, the robot will not enter the High Power state.

The AUTO.POWER.OFF system switch controls if the robot prevents or disables High Power for specific errors. Refer to the *V+ Keyword Reference Manual (Cat. No. I672)* for more information.

## High Power Control Methods

---

There are several methods to control robot High Power as described below.

### ● Front Panel

When a Front Panel is present in the system, the High Power button can be used to request High Power to the robot.

If High Power is enabled, pressing the button will disable High Power.



### Additional Information

---

Refer to *Front Panel Connections* on page 3-38 for more information about connecting external devices to the High Power enable signal on the XFP connector.

---

### ● Connected PC

High Power can be controlled with the ACE software. Refer to the *Automation Control Environment (ACE) Version 4 User's Manual (Cat. No. I633)* for more information.

### ● User Program

High Power can be controlled with a user program through the use of the POWER system switch keyword. Refer to the *V+ Keyword Reference Manual (Cat. No. I672)* for more information.

### ● Pendant

If a pendant is connected to the robot, it can be used to control High Power. Refer to the *T20 Pendant User's Manual (Cat. No. I601)* for more information.

### ● Faults and Emergency Stops

Robot faults and E-stop open circuit detection will disable High Power.

## 4-5 LED Indicators

Use the information below to understand the functionality of LED indicators on the robot.

### 4-5-1 Visual Status LED Indicator

The LED indicator on the top of the outer link provides a visual status of the robot. The LED indications and associated robot states are described below. Refer to *Section 5 Troubleshooting* on page 5-1 for more information on recovering from errors.



#### Precautions for Safe Use

The LED indicator does not reflect the robot's High Power status. To see the robot's High Power status, use the Front Panel indicator or a user-supplied indicator connected to the XFP connector.

LED Indication	Robot State
OFF	Control Power is not present.
Solid White	The robot is initializing.
Solid Blue	The robot is booting.
Bright / Dim Blue	The robot is in an idle state with no errors present.
Bright / Dim Green (1 Hz)	The robot is in a normal operating state while in Automatic mode.
Bright / Dim Green (0.25 Hz)	The robot is in a normal operating state while in Manual mode.
Bright / Dim Red	The robot is in an emergency stop state.
ON / OFF Red	The robot has a system error.

### 4-5-2 PROFINET Device Identification LED Indicators

The ERR (red) and RUN (Green) LED indicators will flash when a DCP signal request is made from a PROFINET configuration tool. These flashing LEDs can be used to identify a particular robot device on the network during configuration or troubleshooting. They can also be used to determine what PROFINET controller is communicating with a particular robot.

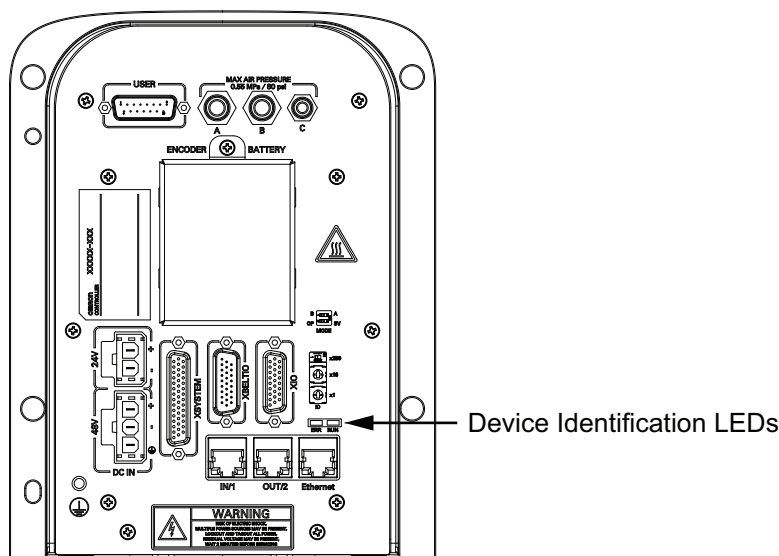

### 4-5-3 Front Panel LED Indicators

Front Panel LED indicator functionality details are provided below.



#### Precautions for Correct Use

If the Front Panel High Power ON / OFF indicator fails, you might incorrectly assume that High Power is OFF, and the robot is safe. To prevent this, a failed indicator causes an error (-924) \*Front panel HIGH POWER lamp failure\* and locks out the High Power enabling until you replace the indicator. Refer to the *V+ User's Manual (Cat. No. I671)* for more information about error handling. Refer to *High Power Indicator Check Procedure* on page 3-51 for information about High Power indicator operation verification.

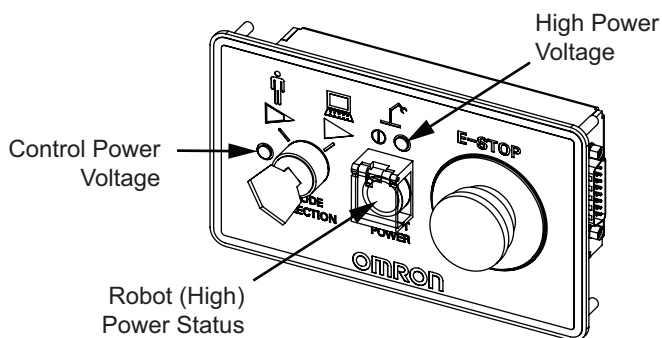

Item	Description
Control Power Voltage	Provides an indication that the robot is receiving 24 VDC Control Power with a green LED.
High Power Voltage	Provides an indication of the robot's High Power state with an amber LED. Refer to <i>4-4 Enabling and Disabling the Robot</i> on page 4-7 for more information.
Robot (High) Power Status	<ul style="list-style-type: none"> <li>• OFF when Robot (High) Power is disabled.</li> <li>• ON when Robot (High) Power is enabled.</li> <li>• Flashing when a High Power enable request is made. Refer to <i>4-4 Enabling and Disabling the Robot</i> on page 4-7 for more information.</li> </ul>

## 4-6 Brake Operation

The robot has a mechanical brake on joints 3 and 4. Releasing the brake is typically done when you need to manually position joint 3 or 4. The brake is controlled with the methods described below. The mechanical brake is capable of preventing the z-axis quill from lowering more than 5 mm when up to 100 N of downward force is applied.

### WARNING

Releasing a brake may cause the quill, tool flange, end-effector, and payload to drop. To prevent possible injury to personnel or damage to the equipment, make sure that the equipment is supported when releasing the brake and verify that the end-effector and payload are clear of all obstructions.



#### Precautions for Safe Use

- The braking mechanism operates passively. If 24 VDC Control Power is removed from the system, the brake mechanism will automatically activate. 24 VDC Control Power must be supplied to release the brake. To prevent possible damage to the equipment, remove any payload from the end-of-arm tooling, make sure that Joint 3 is supported while releasing the brake, and verify that the end-of-arm tooling or other installed equipment is clear of all obstructions.
- In case of entrapment of a person by the robot or any other emergency or abnormal situation, you can manually move the inner and outer links to a safe position while 48 VDC High Power is disabled. A brake device prevents Joints 3 and 4 from moving when High Power is disabled and can only be released while 24 VDC Control Power is present.



#### Precautions for Correct Use

- Attempting to release the brake while High Power is ON will automatically disable High Power. If the robot is moving, this will cause it to stop abruptly.
- Robot joints 1 and 2 have no brake mechanism and can be manually moved when power is not present.
- Avoid rotating the quill / Joint 4 when the brake is released. This could result in an out-of-range condition and may prevent program execution.

### 4-6-1 Built-in Brake Release Button

The brake release button is built-in and integrated into the LED indicator light on the top of the outer link. Pressing this button while the 24 VDC Control Power is ON and High Power is disabled will release the brake. The brake will remain released while the button is pressed. Releasing the button will re-enable the brake.

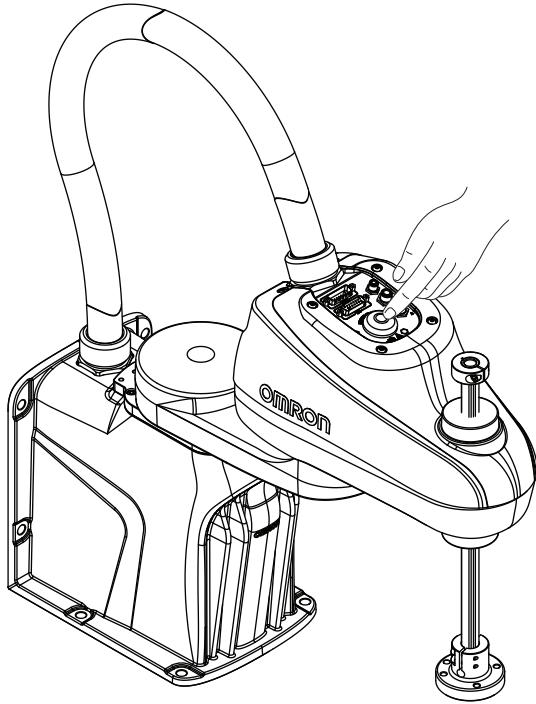

## 4-6-2 Remote Brake Release

The brake can be released with a signal connected to the XIO connector. This is typically used for remote control of the brake.

Use the ACE Software to configure the robot by selecting Enable Brake Release Input. This setting will change the XIO input 6.2 (pin 18) for use as a brake release signal from another device such as a remote pushbutton or an output from another control device. This setting does not affect the normal functionality of the brake release button.



### Additional Information

Refer to the *Automated Control Environment (ACE) Version 4 User's Manual (Cat. No. I633)* for more information about the Enable Brake Release Input robot configuration item.



### Precautions for Safe Use

To comply with ISO 10218-1 when using a remote brake release button, ensure the brake release button displays a warning label to indicate that the z-axis of the robot may fall due to gravity if the brake is released.

## 4-7 Manually Jogging the Robot

---

Manually jogging the robot is typically performed during setup or when teaching locations.



### Precautions for Safe Use

---

During manual operation, ensure all persons are a safe distance away from the robot work envelope.

---

The following considerations should be made when jogging the robot.

- The jog speed and accelerations of the robot are reduced from normal operating speeds and accelerations.
- The jog speed of the robot can be adjusted.
- Robot motion can be incremented by specified amounts when extra precision is needed.
- Jogging can be executed in world, tool, or joint modes.
- The robot can be manually jogged with software or a pendant. Refer to the *Automation Control Environment (ACE) Version 4 User's Manual (Cat. No. I633)* or the *T20 Pendant User's Manual (Cat. No. I601)* for more information.
- The robot can be jogged with the pendant while in Automatic mode or in Manual mode.
- The robot can be jogged with the software while in Automatic mode. If the pendant is connected, it must be set to COMP to allow the software to jog the robot.

## 4-8 Robot Positioning

The information in this section describes important robot positions for typical operation.

### 4-8-1 Joint Zero Position

The robot is at the zero position under the following conditions. When the robot is properly calibrated and positioned at a precision point that consists of all zeros, the robot will have the following orientation.

- The inner link and outer link are fully extended.
- The quill is retracted in the up position.
- The 6 mm through hole on the tool flange is at the position shown below.

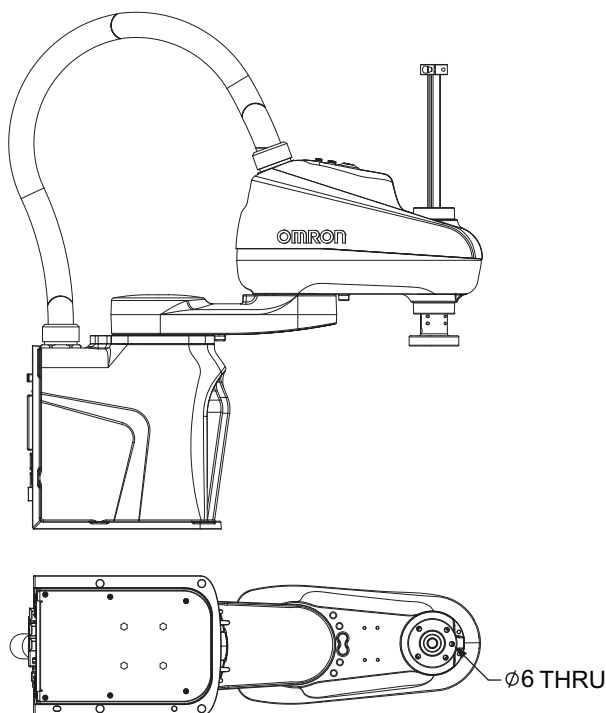

### 4-8-2 Ready Position

Use the READY keyword to place the robot in the ready position. Refer to the *V+ Keyword Reference Manual (Cat. No. I672)* for more information.

Ready positions provide below may vary slightly due to nulling tolerances.

Model	Joint 1 Position	Joint 2 Position	Joint 3 Position	Joint 4 Position
i4-350L	-44.42°	88.83°	10.00 mm	44.42°
i4-450L	-35.10°	99.72°	10.00	64.50°
i4-550Li4-550L (350 mm Z)	-50.48°	100.96°	10.00 mm	50.48°

### 4-8-3 Right-Left Arm Configurations

The robot can operate in a left-arm or right-arm configurations. Select an appropriate configuration for the work area based on your application requirements.

Use the **RIGHTY/LEFTY** keywords to set an arm configuration. Consider specifying the arm configuration before moving the robot to transformation locations. Moves to precision points are not affected by arm configurations because these points are unique joint positions. Refer to the *V+ Keyword Reference Manual (Cat. No. I672)* for more information.

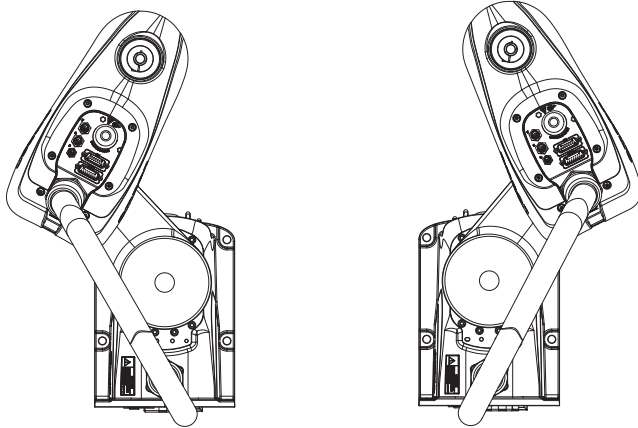

Left Arm  
Configuration

Right Arm  
Configuration

### 4-8-4 Collision Avoidance

Add and adjust obstacles to avoid collision with the robot base, flyover assembly, cables, connectors, wall, or other objects within the work envelope.

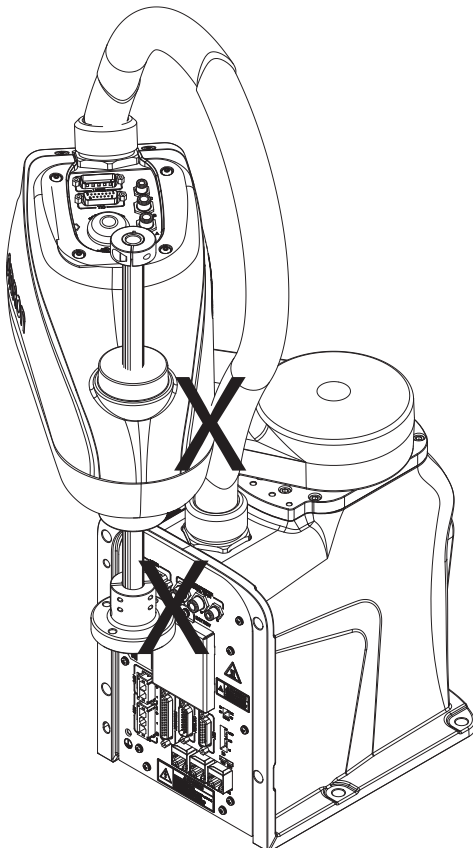



# 5

## Troubleshooting

This section provides robot troubleshooting information.

---

<b>5-1</b>	<b>Fault Detection .....</b>	<b>5-2</b>
<b>5-2</b>	<b>Failure to Power ON .....</b>	<b>5-3</b>
<b>5-3</b>	<b>Emergency Stop Troubleshooting .....</b>	<b>5-4</b>
<b>5-4</b>	<b>Error Messages .....</b>	<b>5-5</b>

## 5-1 Fault Detection

---

Robot faults can be detected with the following methods.

- Create a V+ program to change the state of an output signal when a fault is present. Refer to the *V+ User's Manual (Cat. No. I671)* for more information.
- Use the LED indicator to visually see when a fault is present. Refer to *4-5 LED Indicators* on page 4-9 for more information.
- Connect a PC running the ACE software.

## 5-2 Failure to Power ON

---

Robot failure to power ON is indicated by no LED indicators illuminating or faults displaying. If this occurs make the following checks. Refer to *4-5 LED Indicators* on page 4-9 for robot status while attempting to power ON.

- Check all control power wiring for proper polarity and voltage.
- Check that the 24 VDC Control Power connector is properly fastened to the robot on the Primary Interface Panel.
- Check all ground connections.

If all checks have been verified and the robot fails to power ON, an internal component may be damaged. Contact your local OMRON representative for more information.

## 5-3 Emergency Stop Troubleshooting

If the emergency stop circuit is not operating as expected, the following supplied jumper plugs can be used to troubleshoot the problem. These jumpers can be placed on the XSYSTEM cable to bypass and isolate safety devices. Refer to *3-6-1 System Cable Overview* on page 3-24 for jumper installation locations.

- XFP jumper plug (part number 10052-000)
- XUSR jumper plug (part number 04736-000)
- XMCP jumper plug (10052-000)

### **WARNING**

Never run a robot system with all jumpers installed. This would leave the system with no E-Stops.



## 5-4 Error Messages

The following table lists robot error messages. Use the ACE software to access robot status codes.



### Additional Information

Other system messages may be present. Use the ACE software to check for these messages.

Error Code	V+ Error Message	Explanation	Corrective Action
-606	*Robot overheated*	The temperature sensor on the embedded processor board is at its temperature limit.	Try slowing the motion or insert pauses. Also, check for excessive ambient temperature, inadequate ventilation, and proper function of any cooling fans.
-643	*E-STOP detected by robot*	An E-STOP condition has been detected by the robot.	Remove the source of the E-STOP and re-enable High Power.
-648	*Safety System Not Commissioned*	The E-Stop Delay has not been commissioned and verified. The Teach Restrict has not been commissioned and verified.	In the ACE software, use the Safety Settings under the Configure menu to Configure and Verify ESTOP Hardware Delay. If the error persists, an internal robot component may be damaged. Contact your local OMRON representative for more information.
-651	*RSC communications failure*	There is a failure to communicate with the Robot Signature Card.	Contact your local OMRON support.
-670	*RSC power failure*	The 24 VDC input voltage is out of bounds (too high or low). The high-voltage DC bus for the amplifiers is out of bounds (too high or low). A loss of High Power was detected.	Check connections and voltage level from the user-supplied 24 VDC power supply. Check High Power connections for shorts or opens. Turn High Power back ON and restart the program. If the error persists, contact your local OMRON support.
-1007	*Motor stalled* Mtr #	A motor stall occurs when the maximum allowed torque was applied on a given motor for longer than the timeout period. Typically occurs when an obstacle is encountered.	Check for obstacles and free movement of all joints. Turn High Power back on and repeat the motion that failed.

Error Code	V+ Error Message	Explanation	Corrective Action
-1009	*Safety System Fault* Code 0	Robot hardware did not detect pressing the Front Panel High Power button before the servo system attempted to enable power.	Contact your local OMRON support.
	*Safety System Fault* Code 1	Contact your local OMRON support.	
	*Safety System Fault* Code 2	The safety system failed on channel 1 during the cyclic check of dual-channel power system. This may indicate a welded relay contact or other hardware failure.	Contact your local OMRON support.
	*Safety System Fault* Code 3	The safety system failed channel 2 during the cyclic check of dual-channel power system. May indicate hardware failure.	
	*Safety System Fault* Code 4	The internal E-STOP delay timer timed out and turned power off. Normally, software sequences the shutdown before the time-out.	
	*Safety System Fault* Code 5	The power system was improperly unlocked by software during a power sequence in manual mode.	
	*Safety System Fault* Code 6	CAT-3 hardware safety system detected an encoder OVERSPEED and turned power off. This circuit is active in Manual mode only on select robots which have the CAT-3 teach mode option.	Intentionally triggered during specific commissioning tests for the CAT-3 system. If during normal operation, contact your local OMRON support.
	*Safety System Fault* Code 9	Error reported by the watchdog circuit that cross-checks the clocks for the dual-channel safety system.	Contact your local OMRON support.
	*Safety System Fault* Code 10	An error was detected during a software self test of a secondary safety and monitoring circuit (SRV_DIRECT / SRV_STAT).	
	-1016	*Motor overheating* Mtr #	The motor encoder temperature sensor indicates an over temperature.
-1018	*Motor Amplifier Fault*	A power amplifier fault is indicated on axis #.	Check user motor power connections for shorts or opens. Turn High Power back ON and restart the program. If the error persists, contact your local OMRON support.

Error Code	V+ Error Message	Explanation	Corrective Action
-1021	*Duty-cycle exceeded* Mtr #	The indicated motor (#) has high power use for too long a period of time. The servo system has disabled power to protect the robot hardware.	<ul style="list-style-type: none"> <li>• Turn High Power back ON and reduce the speed or acceleration for the motion that was in progress or for motions that preceded the message.</li> <li>• If the robot is operating at low temperatures when this error occurs, perform a warm-up operation at low speeds and acceleration and then resume normal operation.</li> <li>• If the robot is operating at high temperatures when this error occurs, reduce speed, acceleration, or provide additional cooling and then resume operation.</li> </ul>
-1025	*Encoder Fault*	The servo system has detected an electrical or physical condition that resulted in an encoder fault.	Refer to the V+ User's Manual (Cat. No. I671) for more information.
-1027	*Hard envelope error* Mtr #	The indicated motor was not tracking the commanded position with sufficient accuracy as set by the configuration.	Turn on high power and try to perform the motion at a slower speed. Make sure that nothing is obstructing the robot's motion. If the error continues, contact your local OMRON support.
-1115	*Power system failure* Code 0	The dual-channel brake circuit has reported a cyclic check error.	Contact your local OMRON support.
	*Power system failure* Code 1	The power system has unexpectedly turned off power.	
	*Power system failure* Code 2	Overvoltage in the high voltage DC bus to the regenerative energy dump circuit.	
	*Power system failure* Code 3	The regenerative energy dump circuit has exceeded its max short term dump rating.	
	*Power system failure* Code 4	Contact your local OMRON support.	
	*Power system failure* Code 5	An inrush error was detected by the power sequencer. This means the high-voltage DC bus failed to rise at the expected rate when power was enabled.	
-1200	*Fieldbus invalid configuration*	Fieldbus configuration is wrong or does not align with the controller.	Check the configuration of the device and controller to ensure they match. Use the FB.ERROR Keyword to return additional error information.
-1201	*Fieldbus connection loss*	The fieldbus connection was lost.	Check controller state and fieldbus connection. Use the FB.ERROR Keyword to return additional error information.

Error Code	V+ Error Message	Explanation	Corrective Action
-1202	*Fieldbus system initialization fault*	Fieldbus general fault.	Contact your local OMRON representative.
-1203	*Fieldbus data is invalid*	The fieldbus data was invalid.	<ul style="list-style-type: none"><li>• Make sure the controller has not stopped.</li><li>• Make sure the data from the controller is not corrupted.</li><li>• Make sure the submodule is valid.</li><li>• Use the FB.ERROR Keyword to return additional error information.</li></ul>

# 6

## Maintenance

This section provides information for maintaining the robot.

---

<b>6-1</b>	<b>Periodic Maintenance .....</b>	<b>6-2</b>
6-1-1	Periodic Maintenance Overview .....	6-2
6-1-2	Checking Safety Functions.....	6-2
6-1-3	Checking Fastener Torques .....	6-3
6-1-4	Checking Safety and Warning Labels .....	6-4
6-1-5	Checking for Lubricant Leaks .....	6-4
6-1-6	Lubricating Joint 3 .....	6-5
6-1-7	Replacing Encoder Backup Batteries .....	6-6
6-1-8	Cleaning the Robot.....	6-7
6-1-9	Bellows Inspection.....	6-8
<b>6-2</b>	<b>Non-periodic Maintenance .....</b>	<b>6-9</b>
6-2-1	Replacing the Tool Flange.....	6-9

## 6-1 Periodic Maintenance

This section lists when to perform periodic maintenance on the robots and the steps for checking each item to inspect.

### WARNING

- Never connect or disconnect system cables while power is applied to the robot. Failure to comply may cause unexpected behavior and can result in personnel injury and equipment damage.
- You must perform the Lockout and Tagout procedure prior to servicing the robot.
- The procedures and replacement of the parts mentioned in this manual must be performed only by the skilled or instructed persons.
- The access covers on the robot are not interlocked. You must turn OFF and disconnect the power before the covers of the robot are removed.



### 6-1-1 Periodic Maintenance Overview

The following table gives a summary of the periodic maintenance procedures and guidelines on frequency.

Item	Period	Reference
Check E-Stop, enable and key switches, and barrier interlocks	6 months	Refer to 6-1-2 <i>Checking Safety Functions</i> on page 6-2 for more information.
Check fastener torques	3 months	Refer to 6-1-3 <i>Checking Fastener Torques</i> on page 6-3 for more information.
Check safety labels	1 week	Refer to 6-1-4 <i>Checking Safety and Warning Labels</i> on page 6-4 for more information.
Check the High Power indicator operation	1 week	Refer to <i>High Power Indicator Check Procedure</i> on page 3-51 for more information.
Check for signs of oil around robot joints	3 months	Refer to 6-1-5 <i>Checking for Lubricant Leaks</i> on page 6-4 for more information.
Lubricate the joint 3 quill	3 months or 150 km of travel	Refer to 6-1-6 <i>Lubricating Joint 3</i> on page 6-5 for more information.
Replace the encoder backup batteries	2 to 4 years	Refer to 6-1-7 <i>Replacing Encoder Backup Batteries</i> on page 6-6 for more information.
Clean the exterior of the robot	As needed	Refer to 6-1-8 <i>Cleaning the Robot</i> on page 6-7 for more information.
Bellows inspection	1 week	Refer to 3-4-3 <i>Bellows Kit Installation Procedure</i> on page 3-9 for more information.

### 6-1-2 Checking Safety Functions

All safety devices in the system should be checked regularly for proper functionality. Operating any of the following safety devices should disable robot High Power.

- E-stop button(s) on the Front Panel or connected to the XSYSTEM cable.
- E-stop button and enabling switch on the pendant (if connected).
- All other safety devices connected to the XSYSTEM cable.



### Precautions for Safe Use

The High Power indicator must be operational to satisfy safety requirements.



### Additional Information

Refer to 3-11-3 *Safety Equipment Checks* on page 3-50 for more information.

## High Power Indicator Check

The robot monitors current used by the High Power indicator. This is to ensure that a High Power indicator device is connected and functioning properly to satisfy safety requirements.

If the robot does not detect a current between 10 mA to 500 mA when High Power is requested, an error condition (-924) \*Front panel HIGH POWER lamp failure\* will be present and High Power will not be enabled.

The High Power indicator needs to be periodically checked for correct functionality.

The following considerations should be made before beginning the High Power indicator check procedure.

- Control power and High Power supplies need to be available.
- All connected safety devices must be capable of providing signals for a safe state.
- The robot High Power needs to be disabled and robot motions will not execute during this procedure.
- High Power safety timeout must be enabled to allow the indicator to flash after a High Power request is made. The default setting is 10 seconds. Refer to *Automated Control Environment (ACE) Version 4 User's Manual (Cat. No. I633)* for more information.

### ● High Power Indicator Check Procedure

Use the following procedure to verify that the High Power indicator is working correctly.

- 1** Apply Control Power to the robot and disable High Power.
- 2** Make a High Power request using one of the methods described in *High Power Control Methods* on page 4-8.
- 3** Check that the High Power indicator flashes. After the High Power request is made and the indicator is checked, the procedure is complete.

## 6-1-3 Checking Fastener Torques

The following fasteners must be periodically checked for proper torque.

- Mounting screws: 30 to 32 N-m
- External equipment mounting fasteners (if present): 2.5 N-m (M4 screws), 4.5 N-m (M5 screws)
- Hardstops:
  - Joint 1 hardstops: 17 N-m
  - Joint 2 hardstops: 17 N-m
  - Joint 3 hardstop (clamp collar socket-head screw): 4.5 N-m
- Cable D-sub connectors: finger tight

- Tool flange setscrew: 1.1 N-m
- Tool flange socket-head screws: 2.5 N-m
- Tool flange end-of-arm tooling mounting fasteners: 7.5 N-m

### 6-1-4 Checking Safety and Warning Labels

This section lists the various safety and warning labels and their placement on the robot. Use this information to perform periodic checks.

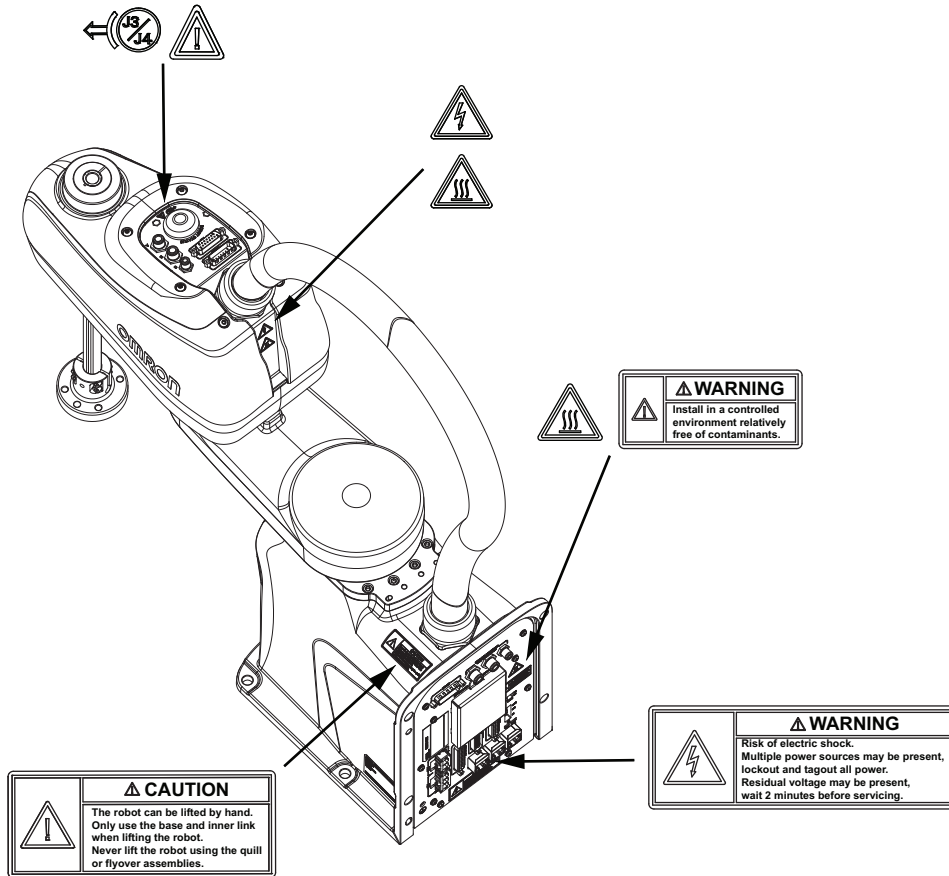

#### Additional Information

The  label indicates the operation of the joint 3 and joint 4 brake.

### 6-1-5 Checking for Lubricant Leaks

The robot has internal lubrication for the joints. Periodically inspect the locations below for signs of leaks.

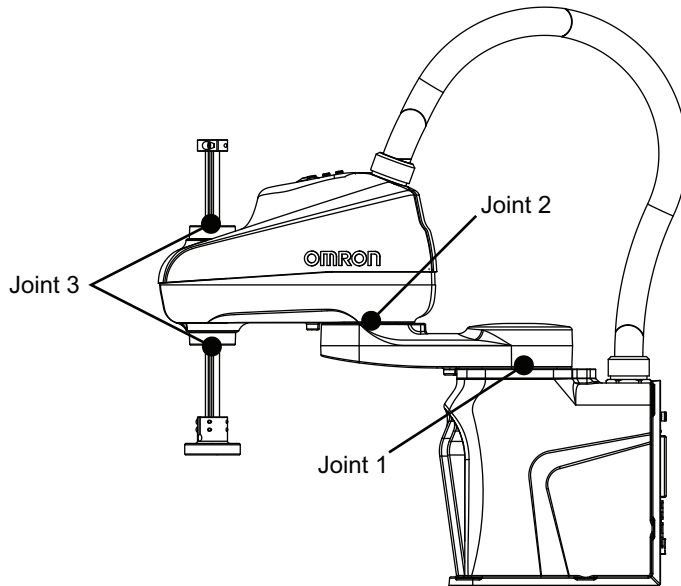

If any leak is detected, do not operate the robot.

Gather the following information and then contact your local OMRON representative.

- Robot model number and serial number. Refer to *1-3 Information Labels* on page 1-11 for more information.
- Description of the exact location of the leak.
- Pictures of the leak.
- Obtain the Diagnostic Summary information using the ACE software. Refer to *Automated Control Environment (ACE) Version 4 User's Manual (Cat. No. I633)* for more information.
- Obtain the LOG.XML file using the ACE software. Refer to *Automated Control Environment (ACE) Version 4 User's Manual (Cat. No. I633)* for more information.

## 6-1-6 Lubricating Joint 3

The joint 3 quill needs to be lubricated on a periodic basis of 3 months or 150 km of linear travel, whichever comes first. 150 km of linear travel is approximately 2 weeks if a robot is operating 24 hours per day for 7 days per week.



### Precautions for Correct Use

Only use the recommended grease on the joint 3 quill. Use THK AFF Grease (part number 20950-000). Refer to the provided Safety Data Sheet for proper handling.

## Joint 3 Lubrication Procedure

Use the following procedure to lubricate joint 3.



### Precautions for Safe Use

The braking mechanism operates passively. If 24 VDC Control Power is removed from the system, the brake mechanism will automatically activate. 24 VDC Control Power must be supplied to release the brake. To prevent possible damage to the equipment, remove any payload from the end-of-arm tooling, make sure that Joint 3 is supported while releasing the brake, and verify that the end-of-arm tooling or other installed equipment is clear of all obstructions.

**Precautions for Correct Use**

Avoid rotating the quill / Joint 4 when the brake is released. This could result in an out-of-range condition and may prevent program execution.

**Additional Information**

- If bellows are present on the robot, they must be removed before this procedure to access the Joint 3 and then reinstalled after this procedure is complete. Refer to *3-4-3 Bellows Kit Installation Procedure* on page 3-9 for more information.
- Ensure there are no z-axis motion restrictions. The full operating stroke is required during this lubrication procedure.

- 1** Press the brake release button while moving the z-axis to the top of its stroke to expose the upper section of the quill.
- 2** Remove any existing grease or debris from the exposed quill with a clean, lint-free cloth.
- 3** Apply grease to all grooves on the quill.  
Dispense a grease amount equivalent to a 6 mm diameter ball (approximately) into each groove.
- 4** Press the brake release button while moving the z-axis to the bottom of its stroke to expose the lower section of the quill.
- 5** Remove any existing grease or debris from the newly exposed section of the quill with a clean, lint-free cloth.
- 6** Move the z-axis up and down to distribute the new grease. This can be accomplished manually with the brake release button or by jogging the z-axis.
- 7** Wipe off any excess grease and remove any visible accumulation to complete this procedure.

**6-1-7 Replacing Encoder Backup Batteries**

Backup batteries maintain joint position data stored by internal encoders. This data is protected by 3 lithium backup batteries located in the Primary Interface Panel.

Encoder backup batteries need to be replaced on a periodic basis of 2 to 4 years or when a low battery alarm is present.

Before beginning the replacement procedure, have the following items available.

- Cross-head screwdriver, point size #1
- Replacement batteries (single battery part number 20269-000F). Three batteries are required for the replacement procedure.

**Encoder Backup Battery Replacement Procedure**

Use the following procedure to replace encoder backup batteries.

Voltage must be maintained during the encoder backup battery replacement procedure to preserve joint position data. If 24 VDC Control Power is available, apply it to the robot during the battery

replacement procedure. If 24 VDC Control Power is not available during the battery replacement procedure, replace one battery at a time and do not allow all three batteries to be absent from the compartment.



### Precautions for Safe Use

- Batteries may leak, rupture, heat, or ignite. Never short-circuit, charge, disassemble, heat, or incinerate a battery or subject it to strong shock.
- Dispose of any battery that has been dropped or otherwise subjected to excessive shock. Batteries that have been subjected to shock may leak if they are used.
- Customers can contribute to resource conservation and protecting the environment by the proper disposal of WEEE (Waste Electronics and Electrical Equipment). All electrical and electronic products should be disposed of separately from the municipal waste system via designated collection facilities. For information about disposal of your old equipment, contact your local OMRON representative.



### Precautions for Correct Use

Only replace items on the robot system with the parts supplied by OMRON.

- 1 Remove the encoder battery compartment cover fastener screw and then remove the cover.  
Encoder Battery Compartment  
Cover Fastener Screw

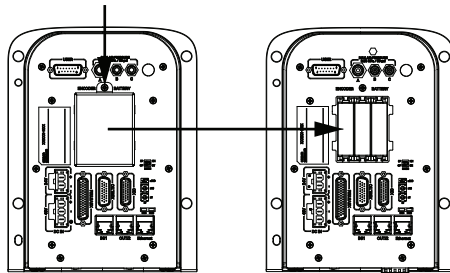

- 2 Remove and replace the batteries while observing orientation for correct polarity indicated in the battery compartment (upwards is positive).
  - If 24 VDC Control Power is present, remove and replace all three batteries.
  - If 24 VDC Control Power is not present, remove and replace only one battery at a time.
- 3 After all batteries have been replaced, fasten the battery compartment cover to the Primary Interface Panel to complete this procedure.

## 6-1-8 Cleaning the Robot

Clean the exterior of the robot as needed using a lint free cloth and moderate cleaning agents, if needed. Inspect the external surface of the robot frequently when used in a dirty environment.

Remove any dirt and debris from the exterior of the robot. Debris can accumulate around robot joints. Take extra effort to clean around these areas.

 **WARNING**

Do not use organic solvents to clean any part of the robot. Organic solvents might damage electronics resulting in an unsafe operating state that could cause injury or damage to equipment.



**6-1-9 Bellows Inspection**

Check the bellows each week for cracks, wear, or damage and replace if necessary. Refer to the *3-4-3 Bellows Kit Installation Procedure* on page 3-9 for replacement and installation steps.

## 6-2 Non-periodic Maintenance

This section provides information about performing maintenance that does not occur at regular intervals.

### WARNING

- Never connect or disconnect system cables while power is applied to the robot. Failure to comply may cause unexpected behavior and can result in personnel injury and equipment damage.
- You must perform the Lockout and Tagout procedure prior to servicing the robot.
- The procedures and replacement of the parts mentioned in this manual must be performed only by the skilled or instructed persons.
- The access covers on the robot are not interlocked. You must turn OFF and disconnect the power before the covers of the robot are removed.



### 6-2-1 Replacing the Tool Flange

Replace the tool flange if it gets damaged.

Before beginning the procedure, have the following tools available.

- 2.5 mm hex bit
- 3 mm hex bit
- Torque wrench
- Loctite thread lock type 243 or equivalent
- Loctite thread lock type 222MS or equivalent

### DANGER

Failure to ground robot-mounted equipment or tooling that uses hazardous voltages could lead to injury or fatality of a person touching the end-effector during an electrical fault.



### WARNING

If air pressure is present, disconnect it from the robot when servicing end-of-arm tooling or other pneumatic components to prevent unsecured pneumatic air lines from accidentally injuring personnel.



#### Precautions for Safe Use

The Joint 3 quill and the tool flange are not grounded to protective earth. If hazardous voltages are present at any user-supplied robot-mounted equipment or tooling, you must install a ground connection from that equipment or tooling to the ground point on the robot base. Refer to *3-10-1 Grounding the System* on page 3-47 for more information about grounding the Tool Flange.



#### Precautions for Correct Use

When removing and replacing the tool flange, you must reinstall it in the same position to avoid losing the calibration for the robot.

## Tool Flange Replacement Procedure

Use the following procedure to replace the tool flange on the z-axis quill if necessary.

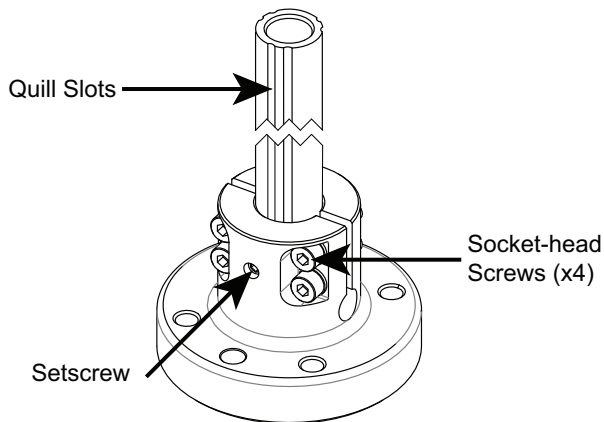

- 1** Take note of the old tool flange position and orientation on the quill.
- 2** Loosen the setscrew and socket-head screws while holding the old tool flange in place. This prevents it from falling off the z-axis quill.
- 3** Slide the tool flange off the z-axis quill.
- 4** Align the setscrew with the proper groove in the z-axis quill.
- 5** When the orientation is correct, slide the new tool flange up on the z-axis quill until it stops.
- 6** Apply thread lock (Loctite 243 or equivalent) to the setscrew and tighten to a torque of 1.1 N-m.



### Precautions for Correct Use

Do not over-tighten the tool flange setscrew. This will cause off-center alignment of the tool flange on the quill.

- 7** Apply thread lock (Loctite 222MS or equivalent) to the socket-head screws and then use a torque wrench to tighten one of the socket-head screws to 1 N-m. Then, apply the same torque to the other socket-head screws. Finally, tighten each socket-head screw to the full 2.5 N-m torque.
- 8** When all socket-head screws are tight and the new tool flange is verified to be in the correct orientation, the replacement procedure is complete.



# Appendices

---

---

<b>A-1</b>	<b>Unpacking and Inspecting the Robot.....</b>	<b>A-2</b>
A-1-1	Before Unpacking the Robot.....	A-2
A-1-2	Unpacking the Robot.....	A-2
<b>A-2</b>	<b>Repacking the Robot for Transport.....</b>	<b>A-4</b>
<b>A-3</b>	<b>Transportation and Storage Considerations .....</b>	<b>A-5</b>
<b>A-4</b>	<b>Cable Pinouts .....</b>	<b>A-6</b>
A-4-1	XSYSTEM Cable Pinouts.....	A-6
A-4-2	XBELTIO Adapter Cable Pinouts .....	A-7
A-4-3	Belt Encoder Y-adapter Cable Pinouts .....	A-8
<b>A-5</b>	<b>I/O Signal Numbering.....</b>	<b>A-10</b>
A-5-1	Input Signal Numbering.....	A-10
A-5-2	Output Signal Numbering .....	A-10
<b>A-6</b>	<b>Parts List.....</b>	<b>A-11</b>

# A-1 Unpacking and Inspecting the Robot

This section provides information about unpacking and inspecting the robot.

## A-1-1 Before Unpacking the Robot

Before unpacking the robot, carefully inspect all shipping containers for evidence of damage during transit. Pay special attention to any tilt and shock indication labels on the exteriors of the containers.



### Precautions for Correct Use

If any damage is detected before unpacking the robot, request that the carrier's agent be present when you unpack the container.

## A-1-2 Unpacking the Robot

The robot ships fastened to a pallet with the following items included inside the container.

- Accessories box
- Documents
- Software

Use the following procedure to unpack the robot from its shipping container. The following tools are required:

- 6 mm hex key
- Cutting tools for securing straps and stretch wrap.



### Additional Information

Retain all containers and packaging materials. These items may be necessary if there is any apparent damage or relocation becomes necessary at a later date.

Prepare the mounting surface and have all mounting items available before beginning this procedure so the robot can be mounted immediately after unpacking. Refer to *3-2-2 Mounting Procedure* on page 3-5 for more information.



### Precautions for Safe Use

The robot can be lifted by hand. Only use the base and inner link when lifting the robot. Never maneuver the robot using the quill or flyover assemblies.



### Precautions for Correct Use

If the robot has a bottom Primary Interface Panel orientation, do not temporarily set the robot upright on a flat surface because this can damage the Primary Interface Panel connectors.

- 1** Begin by placing the shipping container on a flat and level surface.
- 2** Remove the straps that secure the outer shell to the pallet.
- 3** Lift the outer shell up and off the pallet and set it aside.

- 4** Remove the straps that secure the accessory box to the pallet and set it aside.
- 5** Inspect the entire robot for damage before proceeding. If any damage is evident, take pictures, do not proceed further, and contact your local OMRON representative for support.
- 6** Remove the 4 M8 X 50 screws that fasten the robot to the pallet.



## WARNING

The robot's center of mass can cause the robot to fall over if the robot is not properly secured with the mounting bolts.



Do not reuse the screws to mount the robot. They are not sufficient grade.

- 7** Lift the robot and relocate it to the mounting surface.
- 8** Fasten the robot to the mounting surface using the *3-2-2 Mounting Procedure* on page 3-5. When the robot is fastened to the mounting surface, the unpacking procedure is complete. After the robot is fastened to the mounting surface, the stretch wrap and quill foam padding can be removed.

## A-2 Repacking the Robot for Transport

---

The robot must be carefully packed if it needs to be transported. Reuse all original packing containers and materials and follow all safety guidelines detailed in the installation section of this manual. Reverse the installation instructions and unpacking instructions provided in this manual to repack the robot.

# A-3 Transportation and Storage Considerations

---

This section provides details about transporting and storing your robot.



## Precautions for Safe Use

---

- This equipment must be shipped and stored in a temperature-controlled environment, within the range  $-25$  to  $+55^{\circ}\text{C}$ . The recommended humidity range is 5 to 90%, non-condensing. It should be shipped and stored in the supplied packaging, which is designed to prevent damage from normal shock and vibration.
  - Do not expose the shipping container to excessive shock and vibration. This could damage the robot.
- 

Always keep the ISO double-arrows on the sides of the shipping container oriented up.

## A-4 Cable Pinouts

Cable pinout information is provided below.

### A-4-1 XSYSTEM Cable Pinouts

Use the following diagrams for XSYSTEM cable pinout information.



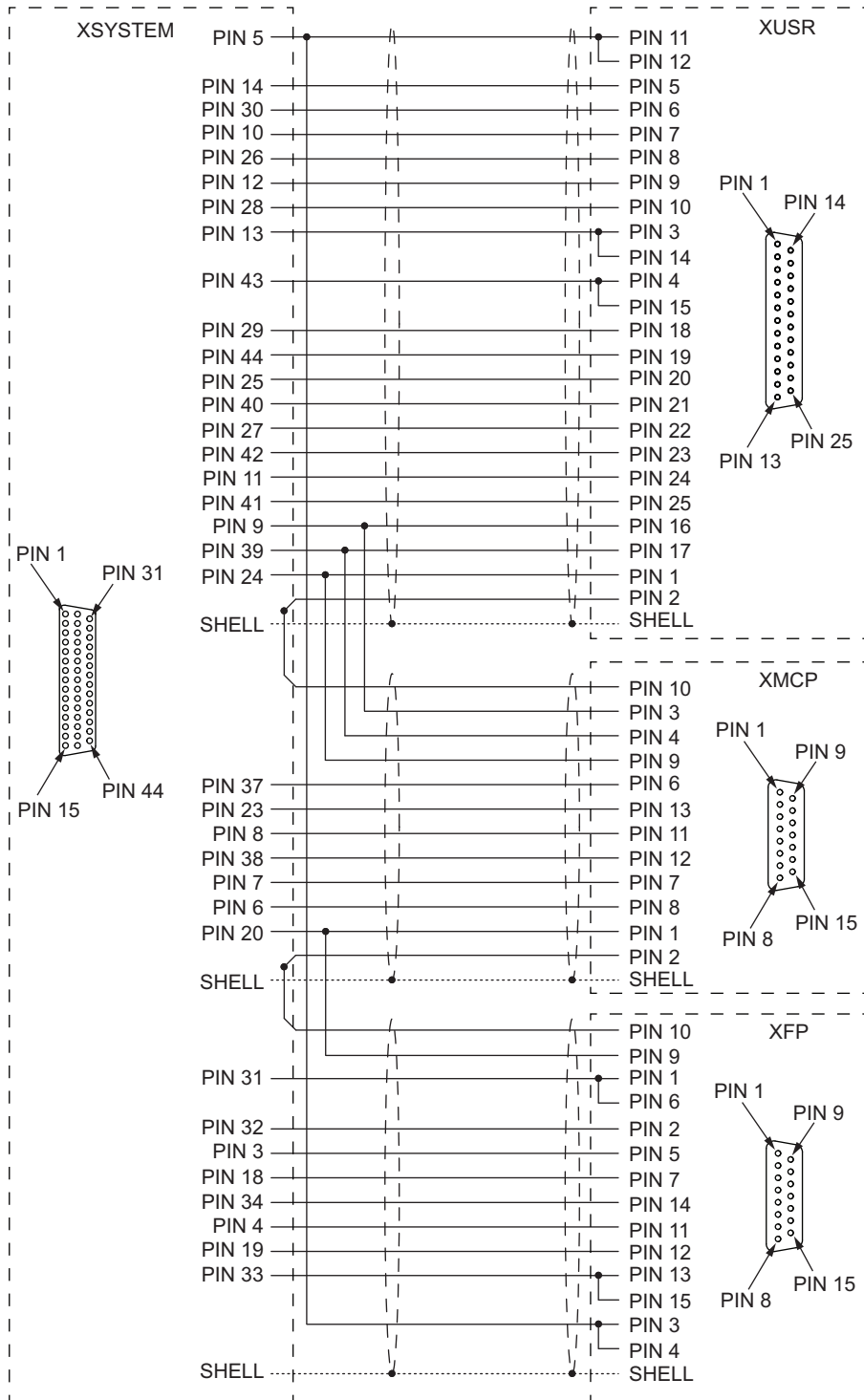

A-4 Cable Pinouts

**A**

A-4-2 XBELTIO Adapter Cable Pinouts

**A-4-2 XBELTIO Adapter Cable Pinouts**

Use the following diagrams for XBELTIO adapter cable pinout information.

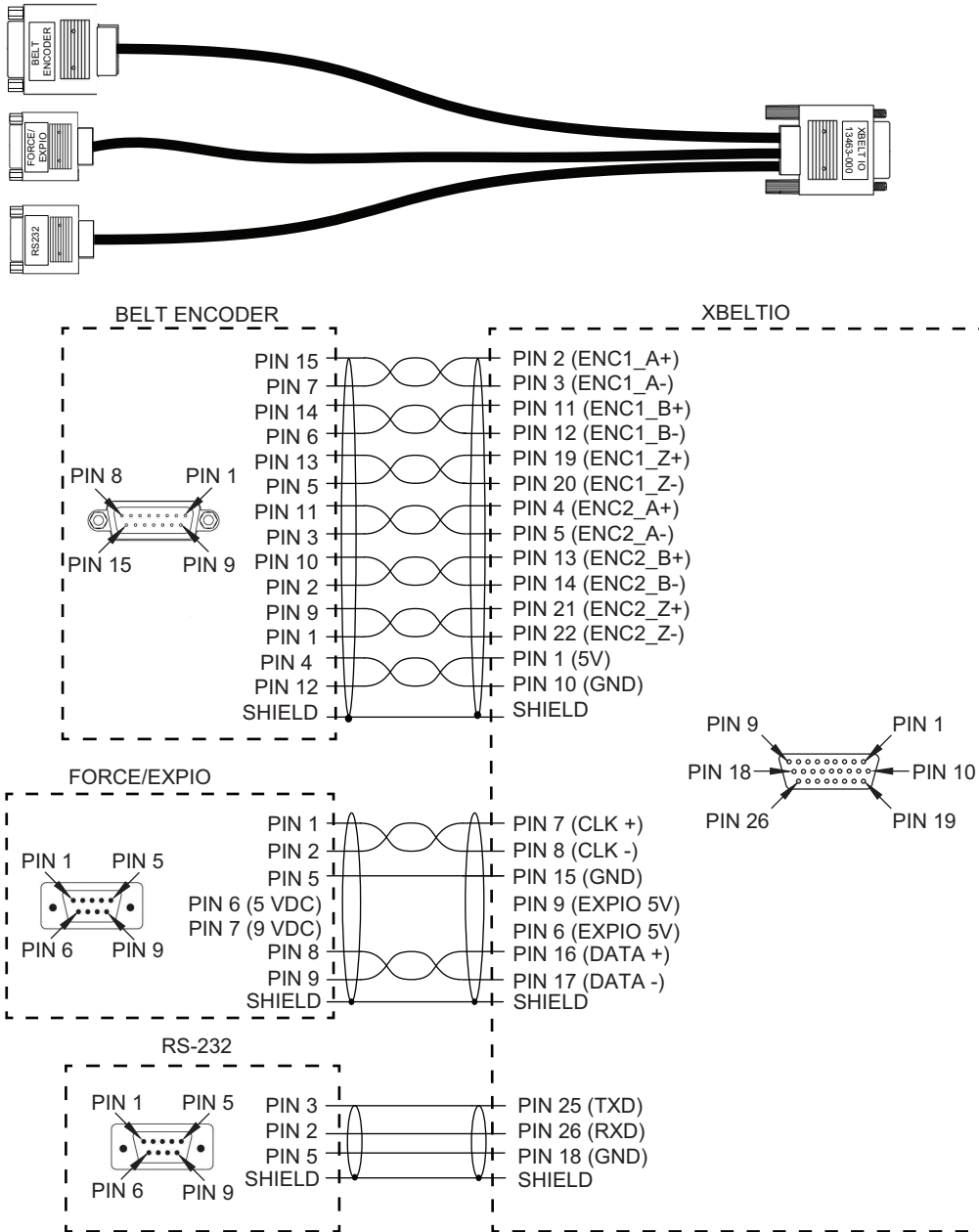

### A-4-3 Belt Encoder Y-adapter Cable Pinouts

Use the following diagrams for Belt Encoder Y-adapter cable pinout information.

Encoder 1  
(M12, Female, 8 PIN)



Encoder 2  
(M12, Female, 8 PIN)



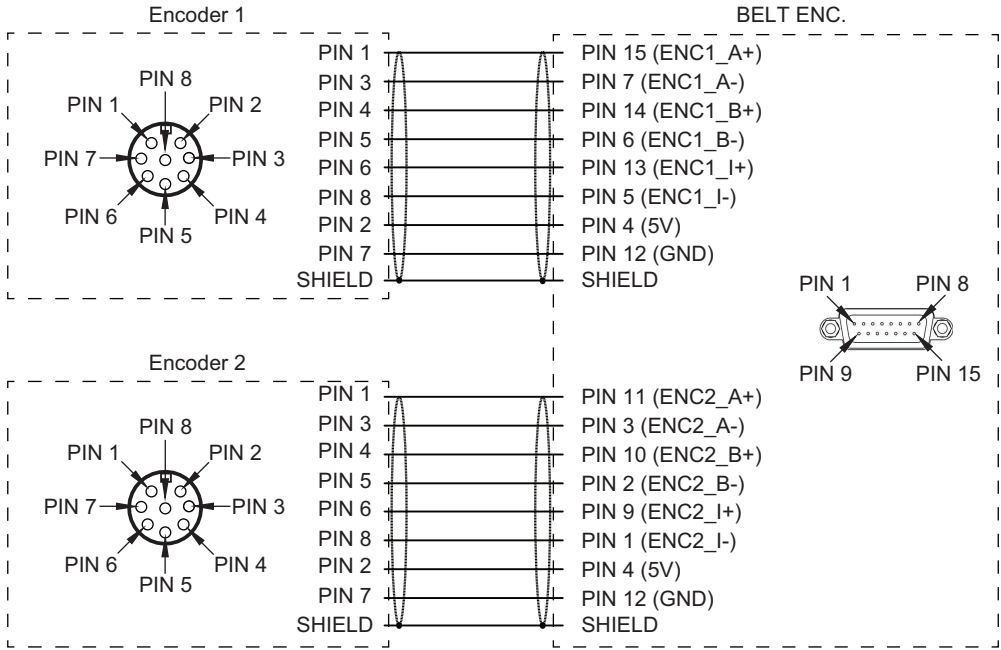

**A**

## A-5 I/O Signal Numbering

Digital I/O for the V+ programming language uses numeric signal numbers in the ranges provided below based on the I/O configuration of the system.

### A-5-1 Input Signal Numbering

Use the table below to understand the digital input signal numbers.

Input Type	Switch Position	Input Signal Numbers
XIO	--	1001 to 1012
TIO		1017 to 1021 <sup>*1</sup>
IO Blox 1	OFF, OFF	1065 to 1072
IO Blox 2	ON, OFF	1073 to 1080
IO Blox 3	OFF, ON	1081 to 1088
IO Blox 4	ON, ON	1089 to 1096

\*1. Systems using firmware version 2.6 use V+ signal numbers in the range of 1033 to 1037 for TIO inputs.

### A-5-2 Output Signal Numbering

Use the table below to understand the digital output signal numbers.

Output Type	Switch Position	Output Signal Numbers
XIO	--	1 to 8
TIO		17 to 20 <sup>*1</sup>
IO Blox 1	OFF, OFF	65 to 72
IO Blox 2	ON, OFF	73 to 80
IO Blox 3	OFF, ON	81 to 88
IO Blox 4	ON, ON	89 to 96

\*1. Systems using firmware version 2.6 use V+ signal numbers in the range of 33 to 36 for TIO outputs.

## A-6 Parts List

Standard robot parts and accessories are provided in the following table.

	Item	Ordering Code	Details
Cables	XSYSTEM cable	13323-000	Provides connections and jumpers for a Front Panel, Teach Pendant, and other user-supplied devices.
	XBELTIO Cable	13463-000	Provides connections to Belt Encoder, EXPIO, and RS-232 signals.
	XIO Breakout Cable	04465-000	Provides a flying leads connection to digital I/O at the XIO connector on the robot.
	IO Blox Extension Cable (to robot)	04677-030	Extends the connection between the IO Blox and the robot up to 3 m.
	IO Blox Extension Cable (to robot)	04677-003	Extends the connection between the IO Blox and the robot up to 300 mm.
	IO Blox Extension Cable (between units)	04679-030	Extends the connection between IO Blox units up to 3 m.
	IO Blox Extension Cable (between units)	04679-003	Extends the connection between IO Blox units up to 300 mm.
	Encoder Extension Cable	09446-050	Replaces or extends encoder cable up to 5 m.
	Belt Encoder Y-adapter Cable	09443-000	Provides two M12 connectors for the Belt Encoder signals/connector on the XSYSTEM cable.
Connectors / Jumpers	High Power Connector	22009-000F	3 position High Power connector, 4 pins, and a grounding screw.
	Control Power Connector	02708-000F	2 position Control Power and 3 connector pins.
	XFP Jumper Plug	10053-000	
	XUSR Jumper Plug	04736-000	
	XMCP Jumper Plug	10052-000	
	T20 Pendant Jumper Plug	10048-000	

	Item	Ordering Code	Details
Other Items	Encoder Backup Battery	20269-000F	A single battery is provided. Three are required for replacement purposes.
	Front Panel Kit	92546-10358	Kit includes front panel and 3 m cable.
	Tool Flange	19360-016F	
	Conveyor Tracking Add-on	09742-001	Provides the components required to connect a second encoder to a SmartController. Used for a system running ACE PackXpert.
	XIO Termination Block and Cable	90356-40100	Provides terminal block digital I/O connections at the XIO connector on the robot. Includes a terminal block with a 2 m cable.
	T20 Pendant Kit	10046-010	Kit includes the pendant, 3 m adapter cable, and a jumper plug.
	T20 Pendant Wall Bracket	10079-000	
	IPC Application Controller	AC1-152000	Includes ACE software pre-installed.
	IO Blox Kit (robot connection)	90356-30200	Includes IO Blox unit and 300 mm cable to connect directly to the robot.
	IO Blox Kit (IO Blox connection)	90356-30100	Includes IO Blox unit and 300 mm cable to connect to another IO Blox unit.
	IO Blox Unit	30410-220	Standalone IO Blox unit.
	Joint 3 Quill Grease	20950-000F	THK AFF type grease.
	Encoder Kit	09742-001	Includes encoder, mounting bracket, and 5 m cable.
	Camera Mounting Kit	22871-000	Used to mount a camera to the outer link. Includes all hardware to mount a Basler or Sentech Camera
	Bellows Kit (180 mm quill)	22839-000	Includes all hardware to install bellows.
	Bellows Kit (350 mm quill)	22868-000	
	Replacement Bellows, 180 mm quill	22861-000F	
	Replacement Bellows, 350 mm quill	22862-000F	
	Pneumatic Valve Kit	22872-000	Includes valves, components, and hardware for installation.
	Control Power Kit	23912-000	Includes a power supply and DC cabling.
High Power Kit	23913-000	Includes power supplies, redundancy unit, and DC cabling.	



# Index



# Index

- A**
- Altitude..... 2-17
- B**
- Base..... 1-5
- Bellows..... 1-21, 3-9
- Bellows Inspection..... 6-8
- Belt Encoder..... 2-16
- Brake
- Force..... 4-11
- Release Button..... 4-11
- Remote Release..... 4-12
- Brake Release..... 1-7
- C**
- Cable Clearances..... 2-4
- Cables
- Belt Encoder Y-adapter..... 1-19, 3-26
- EXPIO to IO Blox..... 3-26
- XBELTIO Adapter..... 1-19, 3-26
- XIO Breakout..... 3-26
- XIO..... 3-26
- XSYSTEM..... 1-9, 3-24
- Camera Mount..... 1-20
- Connectors
- 24 VDC..... 3-48
- 48 VDC..... 3-48
- Control Power..... 1-6, 1-8, 2-19
- High Power..... 1-6, 1-8, 2-19
- TIO..... 1-7, 1-10, 2-19
- USER..... 1-6 – 1-8, 2-19
- XBELTIO..... 1-6, 1-9, 2-19
- XFP..... 3-24
- XIO..... 1-6, 1-9, 2-19
- XMCP..... 3-24
- XSYSTEM..... 1-6, 1-9, 2-19
- XUSR..... 3-24
- Control Power..... 1-23, 2-15, 3-20
- Control Power LED Indicator..... 1-7
- Controller Label..... 1-12
- Cycle Time..... 2-9
- D**
- Dimensions
- Cable Exit Cutout..... 2-4
- i4-350L Overall..... 2-2
- i4-350L Work Envelope..... 2-6
- i4-450L Overall..... 2-3
- i4-450L Work Envelope..... 2-7
- i4-550L (350 mm Z) Overall..... 2-4
- i4-550L (350 mm Z) Work Envelope..... 2-7
- i4-550L Overall..... 2-3
- i4-550L Work Envelope..... 2-7
- Mounting Flange..... 2-4
- Tool Flange..... 2-5
- Front Panel..... 2-5
- E**
- Emergency Stop..... 1-7, 5-4
- Encoder Backup Batteries..... 1-6, 6-6
- End-of-Arm Tooling..... 3-7
- Error Messages..... 5-5
- EtherCAT..... 1-4, 2-18, 3-25
- EtherCAT Node Switches..... 3-45
- EtherCAT Port..... 3-45
- Ethernet Interface Port..... 1-6, 1-9, 2-19
- External Equipment Mounting..... 3-8
- F**
- Faults..... 5-2
- Flyover..... 1-5
- Front Panel..... 1-7
- G**
- Grounding..... 3-47
- H**
- Hardstops..... 3-21
- Joint 2..... 3-22
- Joint 3..... 3-22
- Joint 1..... 3-22
- High Power
- Enabling..... 4-7
- Request Methods..... 4-8
- Safety Timeout..... 4-7
- Humidity..... 2-17
- I**
- I/O Signal Numbers..... A-10
- Inner Link..... 1-5
- IO Blox..... 1-16, 3-35
- IPC Application Controller..... 1-17
- J**
- Jogging..... 4-13
- Joint 1..... 1-5
- Joint 2..... 1-5
- Joint 3..... 1-5
- Joint 4..... 1-5
- Joint Ranges..... 2-9
- Joint Speeds..... 2-9

Joint Zero Position.....	4-14	T20 Pendant.....	1-16
Jumper Plugs		Table Mount Flange.....	1-5
Teach Pendant.....	3-43	Tool Flange.....	1-5
XFP.....	3-42		
XUSR.....	3-40	<b>W</b>	
XMCP.....	3-43		
<b>L</b>		Wall Mount Flange.....	1-5
		Warning Labels.....	6-4
LED Indicator.....	1-7, 4-9	Wiring	
Left Arm.....	4-15	Belt Encoder Y-adapter Cable.....	A-8
<b>M</b>		TIO Connector.....	3-33
		XBELTIO Adapter Cable.....	A-7
Mode Selection Switch.....	1-7	XFP Connector.....	3-40
Mode Switches.....	3-45	XIO Connector.....	3-30
Model Numbers		XMCP Connector.....	3-42
Controller Model Number.....	1-15	XUSR Connector.....	3-39
Robot Model Numbers.....	1-15	XSYSTEM Cable.....	A-6
Modes		<b>X</b>	
Automatic.....	4-5		
Manual.....	4-5	XIO Termination Block.....	1-17
Moment of Inertia.....	2-9	<b>Z</b>	
Mounting			
Surface.....	3-5	Z-axis.....	1-5
Procedure.....	3-5		
<b>O</b>			
Operating Temperature.....	2-17		
Outer Link.....	1-5		
<b>P</b>			
Payload.....	2-9, 4-4		
Pneumatic Pass-through Ports.....	1-6, 1-7, 1-10, 2-19		
Pneumatic Valves.....	1-22, 3-16		
Pollution Degree.....	2-17		
Power Supply.....	1-23, 2-15		
Primary Interface Panel.....	1-6		
Primary Interface_Panel.....	1-6		
PROFINET.....	1-4, 2-19, 3-27		
Protection Class.....	2-17		
<b>R</b>			
Ready Position.....	4-14		
Repeatability.....	2-9		
Right Arm.....	4-15		
Robot Label.....	1-11		
<b>S</b>			
Safety Circuits.....	3-38		
Secondary Interface Panel.....	1-6, 1-7		
Storage Temperature.....	2-17		
Switch Settings.....	3-52		
<b>T</b>			





THIS DOCUMENT CONTAINS IMPORTANT SAFETY INSTRUCTIONS. SAVE THIS DOCUMENT.

## OMRON Corporation Industrial Automation Company

Kyoto, JAPAN

Contact : [www.ia.omron.com](http://www.ia.omron.com)

### Regional Headquarters

#### OMRON EUROPE B.V.

Wegalaan 67-69, 2132 JD Hoofddorp  
The Netherlands  
Tel: (31) 2356-81-300 Fax: (31) 2356-81-388

#### OMRON ASIA PACIFIC PTE. LTD.

438B Alexandra Road, #08-01/02 Alexandra  
Technopark, Singapore 119968  
Tel: (65) 6835-3011 Fax: (65) 6835-3011

#### OMRON ELECTRONICS LLC

2895 Greenspoint Parkway, Suite 200  
Hoffman Estates, IL 60169 U.S.A.  
Tel: (1) 847-843-7900 Fax: (1) 847-843-7787

#### OMRON ROBOTICS AND SAFETY TECHNOLOGIES, INC.

4225 Hacienda Drive, Pleasanton, CA 94588 U.S.A.  
Tel: (1) 925-245-3400 Fax: (1) 925-960-0590

#### OMRON (CHINA) CO., LTD.

Room 2211, Bank of China Tower, 200 Yin Cheng Zhong Road,  
PuDong New Area, Shanghai, 200120, China  
Tel: (86) 21-6023-0333 Fax: (86) 21-5037-2388

Authorized Distributor:

©OMRON Corporation 2022-2025 All Rights Reserved.  
In the interest of product improvement,  
specifications are subject to change without notice.

Cat. No. I658-E-09 0825 (1122)

22607-000 J