

KM50-C

Smart Power Monitor

EN INSTRUCTION MANUAL

Thank you for purchasing this product. This manual describes the functions, performance, and application methods needed for optimum use of the product. Please observe the following items when using the product.

- This product is designed for use by qualified personnel with a knowledge of electrical systems.
- Before using the product, thoroughly read and understand this manual to ensure correct use.
- Keep this manual in a safe location so that it is available for reference whenever required.

OMRON SOCIAL SOLUTIONS CO.,LTD.
© OMRON Corporation 9525589-7 C

PRECAUTIONS ON SAFETY

● Meanings of Signal Words

CAUTION

Indicates a potentially hazardous situation which, if not avoided, will result in minor or moderate injury, or there may be property damage.

CAUTION

Property damage may occur due to fire. Tighten the terminal screws to the specified torques. Recommended terminal screw tightening torque: 0.69 to 0.88 N·m. After tightening the screw, check that the screw is not tilted.

Minor or moderate injury or property damage may occur due to explosion. Do not use the product in locations where explosive or flammable gasses may be present.

Breakdown or explosion may occasionally occur. Use a power supply of the specified voltage.

Breakdown or explosion may occasionally occur. Isolation isn't obtained between the voltage input circuit and the CT secondary circuit. When grounding the dedicated CT, wrong wiring may cause short circuit between the voltage input circuit and the CT secondary circuit. To avoid failure, be sure not to ground CT. Since this product uses the dedicated CT, even if CT isn't grounded, the normal measurement is available.

Electric shock may occasionally occur. Always make sure that the power is turned OFF before connecting the Current Transformer (CT).

Electric shock may occasionally occur. Do not touch the terminals while energized.

Electric shock may occasionally occur. Isolation isn't obtained between the voltage input circuit and the CT secondary circuit. Do not touch the dedicated CT secondary side.

Doing so may occasionally result in electric shock, minor injury, fire, or malfunction of products. Do not try to disassemble, repair, or modify the product.

PRECAUTIONS FOR SAFE USE

- Do not store, install or use the product in the following environment.
 - Locations subject to vibration or strong shocks.
 - Locations where the Unit is unstable.
 - Locations subject to outdoor, direct sunlight, or weather.
 - Locations subject to temperature or humidity beyond the specifications.
 - Locations subject to extreme change in temperature and humidity, resulting in icing or condensation.
 - Locations subject to static electricity or noise.
 - Locations subject to corrosive gases (in particular, sulfide gas and ammonia gas).
 - Locations subject to dust (including iron dust).
 - Locations subject to submergence in water or oil.
 - Locations subject to a electric field or a magnetic field.
 - Locations subject to exposure to saltwater.
- Use the product by mounting it on a control panel with a thickness of 1 to 5 mm. Improper panel thickness or mounting method may result in the product coming off.
- Do not draw out the inside of product. Doing so may increase the contact resistance of the internal terminals, resulting in loss of precision.
- Before operating or performing maintenance of the product, read this Instruction Manual thoroughly to acquire sufficient knowledge of the product. Otherwise electric shock, injury, accident, or malfunction may occur.
- Be sure to check the wiring before turning ON the power of the product, or electric shock, injury, accident, failure, or malfunction due to incorrect wiring may result.
- Use the specified power supply and wires for the supply of control power or inputs. Product failure, burns, or electric shock may occur.
- Do not install the product close to heat-producing devices, a coil for instance.

- Make sure to wire properly after confirming the terminal number.
- Do not connect anything with terminals that are not used.
- Wire the product using crimp terminals for M3.5 screws.
- When installing the product, allow as much space as possible from the equipments that generate powerful high frequency noises, such as high-frequency welders, high-frequency sewing machines or motors, or devices that generate surges.
- Separate the product wiring from high-voltage or high-current power lines to prevent inductive noise, and do not place the product wiring parallel to or in the same ducts or conduits as power lines. Use separate ducts, separate conduits, or shielded cables.
- Do not touch the product or current-carrying parts of the Current Transformer (CT) terminals while power is being supplied.
- This Product cannot be used to measure the inverter's secondary side.
- Allow for proper ventilation. Do not block the area around the product, or the ventilation holes on the product.
- Be sure to touch grounded metal as a measure against electrostatic prior to touching of the product.
- Do not remove the terminal block of the product. It may be a cause for failure or malfunction.
- Do not use the product when the front sheet is torn or broken. Water may enter into the product.
- Install and clearly mark a switch or circuit breaker conforming to requirement in IEC60947-1 and IEC60947-3, to enable immediate power OFF by the operator.
- Always use varistors to between the line of power supply and the line of voltage input when this product installed under overvoltage category III.
- Use our dedicated CTs and dedicated CT cable.
 - Dedicated CT : KM20-CTF-5A KM20-CTF-50A KM20-CTF-100A KM20-CTF-200A KM20-CTF-400A KM20-CTF-600A
 - Dedicated CT cable : KM20-CTF-CB3 (3m)
- This is a class A product. In residential areas it may cause radio interference, in which case the user may be required to take adequate measures to reduce interference.

Precautions for Correct Use

- Set the parameters of the product so that they are suitable for the system being measured.
- As this product is not certified as a specified measuring instrument by measurement law, it cannot be used for proof of electric energy levels.
- Do not use thinner or similar solvent for cleaning. Use commercial alcohol.
- Apply a power supply voltage immediately so that the rated voltage is attained within two seconds. Product may not operate properly.
- Dispose of this product in accordance with local and national disposal regulations.
- When a waterproof structure is required, mount the waterproof packing. Periodic replacement is recommended under an environment where deterioration, shrinkage or hardening may occur. Waterproof packing : Y92S-29
- Before use, remove the front protection film.
- Wire the middle row (11 to 15) at the end.
- When used near a radio, TV set or walkie-talkie, reception interference may occur.

Ratings

Rate power supply voltage	100 to 240 VAC, 50/60 Hz Common terminals of a power supply and a measurement voltage input (terminal number 6 and 7).
Allowable power supply voltage range	85% to 110% of rated supply voltage
Frequency fluctuation range	45 to 65 Hz
Power consumption	7 VA max.
Applicable circuit type	1-phase 2-wire, 1-phase 3-wire, 3-phase 3-wire
Rated input	Rated input voltage 100 to 240 VAC [1-phase 2-wire]: Line voltage 100/200 VAC [1-phase 3-wire]: Phase voltage /line voltage 100 to 240 VAC [3-phase 3-wire]: Line voltage
	Rated input current Dedicated Current Transformer (5, 50, 100, 200, 400, or 600 A)
Rated frequency	50/60 Hz
Rated input power	2 kW at 5 ACT 20 kW at 50 ACT 40 kW at 100 ACT 80 kW at 200 ACT 160 kW at 400 ACT 240 kW at 600 ACT
Allowable input voltage	110% of rated input voltage (Continuous)
Allowable input current	120% of rated input current (Continuous)
Rated input load	Voltage input: 0.5 VA max. (except power supply) Current input: 0.5 VA max. (each input)
Date/Time	2010 to 2099 with leap year adjustment Accuracy: ±1.5 minutes/month (at 23°C)
Backup retention period	3 days (during power OFF) (at 23°C)
Ambient operating temperature	-10 to 55°C (with no icing or condensation)
Conservation temperature	-25 to 65°C (with no icing or condensation)
Ambient operating humidity	Relative humidity 25% to 85%
Conservation humidity	Relative humidity 25% to 85%
Altitude	2,000 m max.
Installation environment	Overvoltage category, Measurement category: II, Degree of contamination: 2

Performance

Accuracy (*1)	Voltage	±1.0% of FS ±1 digit (ambient temperature of 23°C, rated input, rated frequency) However, voltage between Vtr of 3-phase 3-wire and voltage between Vrs of 1-phase 3-wire are ±2.0% of FS ±1 digit under the same condition.
	Current	±1.0% of FS ±1 digit (ambient temperature of 23°C, rated input, rated frequency) However, Is current of 3-phase 3-wire and In current of 1-phase 3-wire are ±2.0% of FS ±1 digit under the same condition.
	Active power	±2.0% of FS ±1 digit (ambient temperature of 23°C, rated input, rated frequency, power factor 1)
	Reactive power	Reactive power calculation formula: Reactive power = v × i × sinθ * "v" and "i" show each instantaneous value. θ is the phase difference between voltage and current.
	Frequency	±0.3 Hz ±1 digit (ambient temperature of 23°C, rated input, rated frequency)
	Power factor	±5.0% of FS ±1 digit (ambient temperature of 23°C, rated input, rated frequency, cosθ = 0.5 to 1.0 to 0.5) Power factor formula: Power factor = active power/apparent power * Apparent power = √(active power) ² + (reactive power) ²
Temperature	±5°C two hours or later after the power turns ON (However, only after correction according to the surrounding environment)	
Low-cut current setting value	0.1% to 19.9% of rated input with 0.1% increments	
Sampling period	100 ms (at 50 Hz), 83.3 ms (at 60 Hz)	
Temperature effect (*1)	±1.0% of FS ±1 digit (power ratio at an ambient temperature of 23°C, rated input, rated frequency, power factor of 1 within the range of operating temperature)	
Frequency effect (*1)	±1.0% of FS ±1 digit (power ratio at an ambient temperature of 23°C, rated input, power factor of 1 within ±5 Hz of the rated frequency)	
Harmonic wave effect (*1)	±0.5% of FS ±1 digit (an error when superimposing harmonic wave of 2nd, 3rd, 5th, 7th, 9th, 11th and 13th orders with the content rate of 30% in current and 5% in voltage on fundamental wave at ambient temperature of 23°C)	
Insulation resistance	1) Between current & voltage input and RS-485 & OUT1 & event input & I/O common: 20 MΩ min (at 500 VDC) 2) Between electric circuit and front case: 20MΩ min (at 500 VDC)	
Dielectric strength voltage	1) Between current & voltage input and RS-485 & OUT1 & event input & I/O common: 2,800 VAC for 1 min. 2) Between electric circuit and front case: 2,800 VAC for 1 min.	
Vibration resistance	Single amplitude: 0.35 mm Acceleration: 50 m/s ² Frequency: 10 to 150 Hz 8 min × 10 times for X, Y and Z directions	
Shock resistance	150 m/s ² for 3 times each in X, Y, and Z directions.	
Weight	Approx. 150 g (main unit only)	
Degree of protection	Front face: IP66, Rear case: IP20, Terminal: IP00	
Memory protection	EEPROM (non-volatile memory) Number of rewrites: 1,000,000 times	
Applicable standards	EN61010-1 (IEC61010-1), EN61326-1 (IEC61326-1)	
EMC (Industrial road)	EMI EN61326-1	Radiation disturbance magnetic field intensity: CISPR11 classA Noise terminal voltage: CISPR11 classA
	EMS EN61326-1	Electrostatic discharge immunity: EN61000-4-2 Magnetic field intensity immunity: EN61000-4-3 Fast transients/burst noise immunity: EN61000-4-4 Surge immunity: EN61000-4-5 Conducted disturbance immunity: EN61000-4-6 Power-frequency magnetic field immunity: EN61000-4-8 Voltage dips and short interruptions immunity: EN61000-4-11

*1 Error of the dedicated CT is not included.

Function and performance

Event input	Number of input	Event input (EV1 and EV2) Common terminal with OUT1
	Voltage input	H level: 4.75 to 30 VDC, L level: 0 to 2 VDC, Input impedance: Approx. 2 kΩ
	None voltage input	ON impedance: 1 kΩ max. OFF impedance: 100 kΩ min. Residual voltage at ON: 8 V max. ON current at 0 Ω: 10 mA max.
	Minimum input time	5 ms
Transistor output	Number of output	Open collector × 1 Integral power consumption pulse output or alarm output × 1, Common terminal with event input
	Output capacity	30 VDC, 30 mA Residual voltage at ON: 1.2 V max. Leakage current at OFF: 100 μA max.
Communication	Communication method	RS-485 (2-wire half-duplex)
	Synchro system	Asynchronous communication
	Unit No. setting	CompoWay/F: 0 to 99, Modbus: 1 to 99
	Baud rate	1.2, 2.4, 4.8, 9.6, 19.2, or 38.4 kbps
	Transmission code	CompoWay/F: ASCII, Modbus: Binary
	Data bit length	7 or 8 bit
	Stop bit length	1 or 2 bit
	Vertical parity	Even, odd and none
Maximum transmission distance	500m	
Maximum connecting units	CompoWay/F: 31, Modbus: 99	

Dimensions (unit: mm)

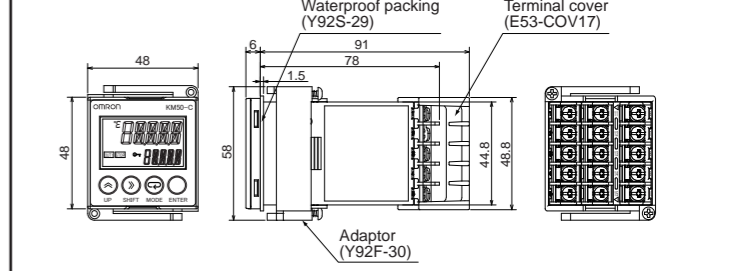

Mount the Product such that the display can be seen properly from the front. To fix the Product to the panel, use the attached adapter. Push the adapter from the terminal side until it hits the panel, and then tighten the panel temporarily. Tighten the fixation screw of the adapter with specified torque. Fixation screw tightening torque : 0.29~0.39N·m

Panel dimensions (unit: mm)



When installing the Products adjoining each other, secure enough space between the products. Reference interval: 60mm (top/bottom/left/right directions) For any product, it is the interval from the center.

Wiring diagram

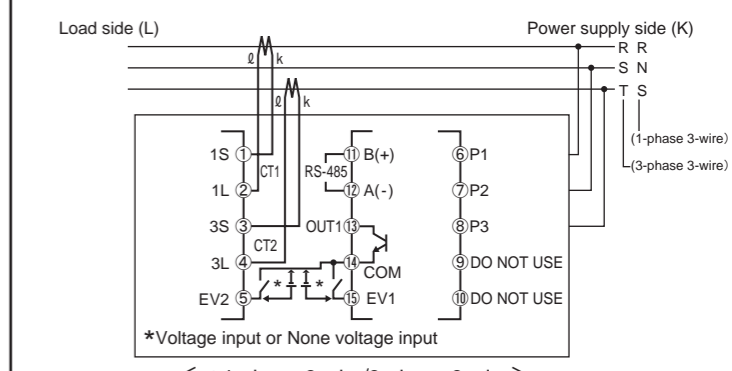
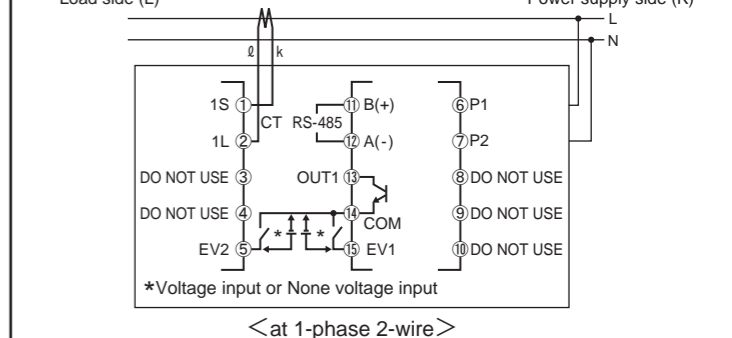

Note: 1. Do not ground the dedicated CT. Otherwise, a trouble may occur.
Note: 2. Do not use the general-purpose CT. Otherwise, a trouble may occur.

Terminal diagram

Terminal number	Terminal name	Terminal number	Terminal name	Terminal number	Terminal name
①	CT1S	⑪	RS-485 B(+)	⑥	P1 voltage
②	CT1L	⑫	RS-485 A(-)	⑦	P2 voltage
③	CT3S	⑬	OUT1	⑧	P3 voltage
④	CT3L	⑭	Input/output common	⑨	DO NOT USE
⑤	Event input2	⑮	Event input1	⑩	DO NOT USE

Main functions

1) Integral power consumption pulse output

When using the integral power consumption pulse output, connect it between terminal Nos. 13 and 14 (terminals set in the output terminal function setting).

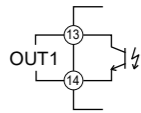

The output pulse cycle can be calculated by the following formula:

$$\text{Output pulse cycle [s]} = 3600 [\text{s}]/\text{Power [W]}/\text{Pulse output unit [Wh]}$$

Ex.:

With the 3-phase 3-wire system, 200k [W] input power and 10k [Wh] pulse output unit, the output pulse cycle is $3600 [\text{s}]/200\text{k [W]}/10\text{k [Wh]} = 180 [\text{s}]$. When 10k [W] input power continues for an hour, the accumulated power energy becomes 10k [Wh] after an hour (3600 sec). With 200k [W] input power, when the pulse output unit is set to 10k [Wh], the output pulse is $200\text{k [W]}/10\text{k [Wh]} = 20$ pulses, and the cycle is $3600 [\text{s}]/20 \text{ pulses} = 180 [\text{s}]$. As shown in the following chart, the pulse is output (ON) every 180 [s].

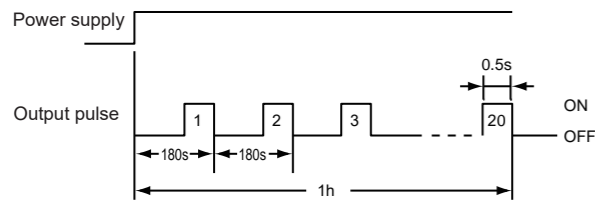

When the cycle is shorter than the pulse width, or the output turns ON just after OFF, it has a 100 ms OFF time.

When the OFF time is shorter, count error may occur due to the relationship with PLC scan time. Set the pulse output unit to an appropriate value.

2) Alarm output

When using the alarm output, connect it between terminal Nos. 13 and 14 (terminals set in the output terminal function setting).

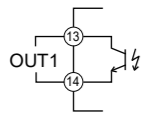

This function turns the alarm ON when the measured value exceeds the upper threshold of alarm output or falls below the lower threshold.

When the alarm output is ON, the alarm output maintains ON unless the measured value is lower/higher than the hysteresis range.

User can set the OFF-delay function, which enables the unit to keep the output ON for the predetermined time when the alarm judgment shifts from ON to OFF, or the ON-delay function, which enables the unit to keep the output OFF for the predetermined time when the alarm judgment shifts from OFF to ON.

While the alarm is going off, the operation indicator OUT 1 lights up and shows the character of alarm output and the present measured value alternately. However, when any of E-S1 - 4 errors occurs, the error display has a priority.

Note: 1. Threshold and hysteresis judges alarm ON/OFF. Alarm goes off based on the alarm judgment taking into account OFF-delay and ON-delay.

Note: 2. When setting the upper threshold of each alarm to maximum, the upper limit alarm function will turn OFF, while setting the lower threshold to minimum, the lower limit alarm will turn OFF.

3) Event input

When using the event input, connect it between terminal Nos. 14 and 15 and terminal Nos. 5 and 14.

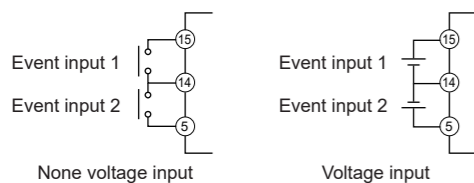

There are two ON/OFF judgment methods: total number of counts of two input values, OR judgment of two input values.

Number of input counts: Power consumption rate management function

OR judgment: Pulse input ON time measurement function

User can set the normal open/close for each input.

In addition, user can set the measurement start time/end time.

Using the event input function, the following parameters can be measured:

Power consumption rate calculation function

Power consumption rate calculation function counts the frequency of event input ON and calculate the power consumption for each count. The total number of ON times of Event input 1 and Event input 2 is defined as input.

Pulse input ON time measurement function

The pulse input ON time measurement function accumulates the event input ON time for a day and displays it.

The OR judgment of Event input 1 and Event input 2 determines the ON time.

User can set the input mode to either of the following two types:

Normal open

It is a logical structure that when there is an event input, the judgment is ON, and when there isn't an event input, the judgment is OFF.

Normal close

It is a logical structure that when there is not an event input, the judgment is ON, and when there is an event input, the judgment is OFF.

The time chart of normal open is as follows:

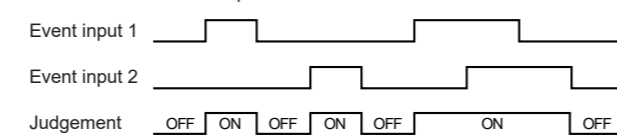

The time chart of normal close is as follows:

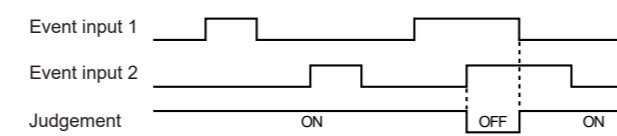

4) Measurement history

Histories can be checked. (See *1 to *4 in the separate sheet.)

Integral power consumption (past 13 months/8 days/25 hours), active power, current, voltage, power factor (max/min: past 8 days), reactive power (max/min of the present day), pulse input count, electric power consumption rate, pulse input ON time (past 8 days)

5) Low-cut function

When a current value becomes lower than the setting of the low-cut value (0.1% to 19.9% of the rated value), the current measurement value forcibly becomes 0. Current (electric power) that is measured due to inductive noise in no-load state can be cut. Judgment is made in a phase where CT is connected.

* Related setting parameter: $04.LUL$

6) Simple measurement

KM50-C can roughly keep track of electric power consumption by setting arbitrary voltage, arbitrary power factor, even if impossible to input a voltage due to a situation in a workplace.

* Accuracy cannot be compensated because value is fixed.

* Frequency cannot be measured. 50 Hz fixed.

* Related setting parameter: $08.5MP$

7) CO₂ conversion

The measured power consumption can be converted to CO₂ value and displayed.

* Conversion factor differs according to areas.

Refer to information sources such as web sites of electric power companies.

* Related setting parameter: $10.LC2$

8) Power rate conversion

The measured power consumption can be converted to the price and displayed.

* Set the conversion factor appropriate to user's currency.

* Related setting parameter: $11.LHG$

9) Pulse conversion

The pulse input count measured can be converted and displayed as a pulse equivalent.

* Set the conversion factor in accordance with what should be converted to pulse.

* For the second display, any unit set can be displayed.

* Related setting parameter: $12.LV1, 13.LV2$

10) Controlling electric power consumption rate

Tact electric power of the production line can be measured (kWh/P). Inputting production quantity to the Product as an event input (pulse) displays the tact electric energy according to integral power consumption during the setting period (one day maximum).

* Related setting parameter: $30.EC5, 31.PN1, 32.PN2, 33.CN1, 34.CN2, 35.SL1, 36.SL2$

11) Accumulate regenerated power and reactive power

Regenerated power, leading reactive power, lagging reactive power and total reactive power can be accumulated.

* Total reactive power: Sum of absolute values of leading and lagging reactive powers

* For the item to store the log every 5 min, user can select one from four options.

* Related setting parameter: $60.L5L$

12) Automatic rotation

This function automatically changes the parameter of measurement mode.

* User can set the automatic transition interval.

* Related setting parameter: $61.PLT$

13) Measurement parameter display selection

For measurement parameters, display OFF/ON can be set to each item.

* Related setting parameter: $62.d5L$

14) Energy saving mode

This function turns off the light when key operation is not implemented.

* User can set the time interval to turn off the light.

* Related setting parameter: $63.d5P$

15) Incorrect voltage wiring detection

This function detects incorrect wiring of voltage input.

When the incorrect wiring is detected, "E-54" is displayed.

* Related setting parameter: $64.V-E$

16) Simple temperature measurement

Simple temperature measurement is available.

* User can select Celsius or Fahrenheit.

* Related setting parameter: $65.d-U$

Communication connection diagram

* Communication standard is RS-485.

* Protocol can be chose between CompoWay/F and Modbus. Number of KM50 connectable (excluding the host equipment) is 31 in CompoWay/F or 99 in Modbus.

* The maximum transmission distance is 500 m.

* Use shielded twist pair cable of AWG 24 or larger.

* Mount a terminating resistor to the devices including a host device connected to both ends of the transmission line.

* For the Product connected to a terminating resistor, connect a terminating resistor of 120 Ω (1/2 W) between terminal number 11 and 12.

* Do not ground RS-485 signal wire. Otherwise, a trouble may occur.

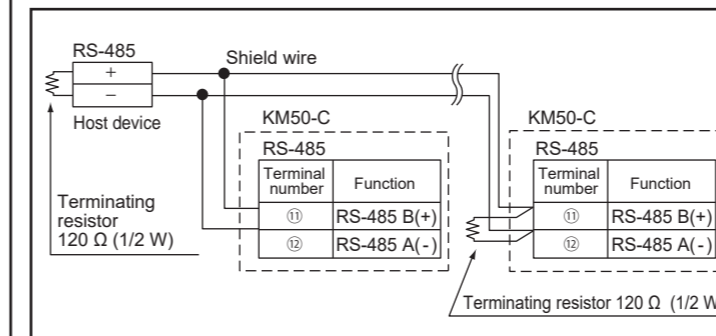

Dedicated CT Connection Diagram

* One dedicated Current Transformer (CT) is required for 1-phase 2-wire measurement,

two dedicated CTs are required for 1-phase 3-wire or 3-phase 3-wire measurement.

* Must use the same rating dedicated CTs for each KM50-C.

* Ratings of dedicated CT and the dedicated CT setting of KM50-C should be the same.

* Be sure to check the directions of power supply side (K) and load side (L) before connecting the dedicated CT.

The wrong connecting direction will result in incorrect measurement.

* Open dividing/fixing hook and clamp to each phase.

After clamping, make sure a clicking sound is heard to ensure engagement.

* Close the CT secondary side terminal cover.

* Do not ground the dedicated CT.

Otherwise, a trouble may occur.

* Dedicated CT is polarized.

Be sure to make a correct connection between k of dedicated CT and 1S or 3S of KM50-C, and between l of dedicated CT and 1L or 3L of KM50-C.

* Electric shock may occasionally occur.

Use coated wires with over 600V basic insulation for the primary side cable.

* Do not use CT with a Bus bar.

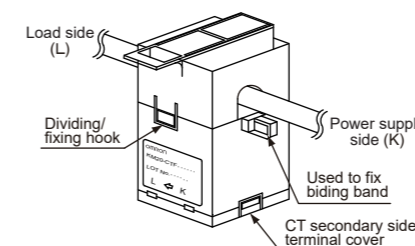

Dedicated Current Transformer specification

Item	Model	KM20-CTF-5A	KM20-CTF-50A	KM20-CTF-100A	KM20-CTF-200A	KM20-CTF-400A	KM20-CTF-600A
Primary side rated current		5A	50A	100A	200A	400A	600A
Secondary windings		3,000 turns			6,000 turns	9,000 turns	
Applicable frequency		10Hz to 5kHz					
Insulation resistance		Between output terminal and outer case: 50 MΩ min (at 500 VDC)					
Dielectric strength voltage		Between output terminal and outer case: 2,000 VAC 1 minute					
Open protective element		7.5 V					
Capable CT		100 times					
Inside diameter		φ7.9mm max	φ9.5mm max	φ14.5mm max	φ24mm max	φ35.5mm max	
Operation temperature		-20 to 60°C 85% max (with no icing or condensation)					
Storage temperature		-30 to 65°C 85% max (with no icing or condensation)					

Precautions for wiring

* To avoid noise interference, separate signal wiring and power wiring.

* For cables, use twist pair AWG24 (φ 0.205 mm²) – AWG14 (φ 2.081 mm²) (Stripping length: 5 – 6 mm).

* For dedicated CT connecting, use the dedicated CT cable (KM20-CTF-CB3: 3 m).

Be sure to connect the shrinkable tube side to dedicated CT.

* Do not ground the dedicated CT and RS-485 signal wire.

Otherwise, a trouble may occur.

* Use crimp-type terminals for wiring.

* Use wiring materials and crimp tools appropriate to crimp-type terminals.

* When connecting multiple wires to the same terminal, screws may not be fully tightened.

Therefore, we recommend crimping all wires together to one crimp-type terminal.

* For terminal screws, set the tightening torque to 0.69 – 0.88 N·m.

* For crimp-type terminals, use M3.5 shaped like the following:

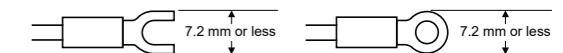

* Do not remove the terminal block because it may cause failure or malfunction.

Suitability for Use

Omron Companies shall not be responsible for conformity with any standards, codes or regulations which apply to the combination of the Product in the Buyer's application or use of the Product. At Buyer's request, Omron will provide applicable third party certification documents identifying ratings and limitations of use which apply to the Product. This information by itself is not sufficient for a complete determination of the suitability of the Product in combination with the end product, machine, system, or other application or use. Buyer shall be solely responsible for determining appropriateness of the particular Product with respect to Buyer's application, product or system. Buyer shall take application responsibility in all cases. NEVER USE THE PRODUCT FOR AN APPLICATION INVOLVING SERIOUS RISK TO LIFE OR PROPERTY OR IN LARGE QUANTITIES WITHOUT ENSURING THAT THE SYSTEM AS A WHOLE HAS BEEN DESIGNED TO ADDRESS THE RISKS, AND THAT THE OMRON PRODUCT(S) IS PROPERLY RATED AND INSTALLED FOR THE INTENDED USE WITHIN THE OVERALL EQUIPMENT OR SYSTEM.

Contact Information

OMRON ELECTRONICS LLC.

One Commerce Drive Schaumburg, IL 60173-5302 U.S.A

Phone: 1-847-843-7900 Fax: 1-847-843-7787

OMRON EUROPE B.V.

Wegalaan 67-69, 2132 JD Hoofddorp The Netherlands

Phone: 31-23-56-81-300 Fax: 31-23-56-81-388

OMRON ASIA-PACIFIC PTE. LTD.

No.438A Alexandra Road #05-05/08(Lobby 2), Alexandra

Technopark, Singapore 119967

Phone: 65-6835-3011 Fax: 65-6835-2711

OMRON CORPORATION

3-4-10 Toranomon Minato-ku, Tokyo, 105-0001 Japan

Phone: 81-3-3436-7260 Fax: 81-3-3436-7261