

# Machine Automation Controller

## NX-series

# EtherCAT® Coupler Unit

## User's Manual

NX-ECC201  
NX-ECC202  
NX-ECC203

EtherCAT Coupler Unit



## NOTE

All rights reserved. No part of this publication may be reproduced, stored in a retrieval system, or transmitted, in any form, or by any means, mechanical, electronic, photocopying, recording, or otherwise, without the prior written permission of OMRON.

No patent liability is assumed with respect to the use of the information contained herein. Moreover, because OMRON is constantly striving to improve its high-quality products, the information contained in this manual is subject to change without notice. Every precaution has been taken in the preparation of this manual. Nevertheless, OMRON assumes no responsibility for errors or omissions. Neither is any liability assumed for damages resulting from the use of the information contained in this publication.

## Trademarks

- Sysmac and SYSMAC are trademarks or registered trademarks of OMRON Corporation in Japan and other countries for OMRON factory automation products.
- Microsoft, Windows, Excel, Visual Basic, and Microsoft Edge are either registered trademarks or trademarks of Microsoft Corporation in the United States and other countries.
- EtherCAT® is registered trademark and patented technology, licensed by Beckhoff Automation GmbH, Germany.
- Safety over EtherCAT® is registered trademark and patented technology, licensed by Beckhoff Automation GmbH, Germany.
- ODVA, CIP, CompoNet, DeviceNet, and EtherNet/IP are trademarks of ODVA.
- The SD and SDHC logos are trademarks of SD-3C, LLC.  

Other company names and product names in this document are the trademarks or registered trademarks of their respective companies.

## Copyrights

Microsoft product screen shots used with permission from Microsoft.

# Introduction

---

Thank you for purchasing an NX-series EtherCAT Coupler Unit.

This manual contains information that is necessary to use the NX-series EtherCAT Coupler Unit.

Please read this manual and make sure you understand the functionality and performance of the NX-series EtherCAT Coupler Unit before you attempt to use it in a control system.

Keep this manual in a safe place where it will be available for reference during operation.

## Intended Audience

This manual is intended for the following personnel, who must also have knowledge of electrical systems (an electrical engineer or the equivalent).

- Personnel in charge of introducing FA systems.
- Personnel in charge of designing FA systems.
- Personnel in charge of installing and maintaining FA systems.
- Personnel in charge of managing FA systems and facilities.

For programming, this manual is intended for personnel who understand the programming language specifications in international standard IEC 61131-3 or Japanese standard JIS B 3503.

## Applicable Products

This manual covers the following product.

- NX-series EtherCAT Coupler Unit
  - NX-ECC201
  - NX-ECC202
  - NX-ECC203

# Relevant Manuals

To use the EtherCAT Coupler Unit, you must refer to the manuals for all related products.

Read all of the manuals that are relevant to your system configuration and application before you use the NX-series EtherCAT Coupler Unit.

Some manuals are referred to by simplified names. Refer to *Precaution on Terminology* on page 6 to identify their original manual names.

Description	System configuration*1								All Units	
	(A)EtherCAT Slave Terminal				(B)EtherCAT master					(C)S up- port Software
	Communica- tions Coupler Unit/End Cov- er	NX Units			CPU Unit / Industrial PC Hardware User's Manual	CPU Unit / Industrial PC Software User's Manual	CPU Unit / Industrial PC Built-in EtherCAT Port User's Manual	CPU Unit / Industrial PC Instructions Reference Manual		
		NX-series EtherCAT Coupler Unit User's Manual	NX-series System Unit User's Manual	NX-series Safety Control Unit User's Manual						User's manuals for other NX Units
										NX-series Data Reference Manual
										Sysmac Studio Version 1 Operation Manual
Learning about Slave Terminals										
System Configuration	<input type="radio"/>									
Support Software connection procedures	<input type="radio"/>									
Specifications	<input type="radio"/>									
Application procedures	<input type="radio"/>									
NX Units that can be connected		<input type="radio"/>	<input type="radio"/>	<input type="radio"/>						<input type="radio"/>
Power supply system	<input type="radio"/>	<input type="radio"/>								
Installation procedures	<input type="radio"/>									
Wiring	<input type="radio"/>									
Settings and setting procedures	<input type="radio"/>									
I/O data exchange with EtherCAT masters or NX Units	<input type="radio"/>									
Calculations of communications perform- ance	<input type="radio"/>									
Procedures for using safety control sys- tems			<input type="radio"/>							
Calculations of safety control system per- formance			<input type="radio"/>							
Learning about Units on Slave Terminals										
Specifications	<input type="radio"/>	<input type="radio"/>	<input type="radio"/>	<input type="radio"/>						

Description	System configuration*1								All Units	
	(A)EtherCAT Slave Terminal				(B)EtherCAT master					(C)S up- port Soft- ware
	Communica- tions Coupler Unit/End Cov- er	NX Units			CPU Unit / Industrial PC Hardware User's Manual	CPU Unit / Industrial PC Software User's Manual	CPU Unit / Industrial PC Built-in EtherCAT Port User's Manual	CPU Unit / Industrial PC Instructions Reference Manual		
		NX-series EtherCAT Coupler Unit User's Manual	NX-series System Unit User's Manual	NX-series Safety Control Unit User's Manual						User's manuals for other NX Units
Functionality	<input type="radio"/>	<input type="radio"/>	<input type="radio"/>	<input type="radio"/>						
Application procedures	<input type="radio"/>	<input type="radio"/>	<input type="radio"/>	<input type="radio"/>						
Wiring I/O power supply terminals and power supply terminals	<input type="radio"/>	<input type="radio"/>	<input type="radio"/>	<input type="radio"/>						
Learning about values of NX Units for performance calculations									<input type="radio"/>	
Learning about NX Units with restrictions on communications cycles									<input type="radio"/>	
Learning about restrictions that each NX Unit has on Communications Coupler Unit functions									<input type="radio"/>	
Referencing data lists for NX Unit <i>power consumptions, weights</i> etc.									<input type="radio"/>	
Making settings for functions of Units on Slave Terminals	<input type="radio"/>	<input type="radio"/>	<input type="radio"/>	<input type="radio"/>						
Making other settings than the above								<input type="radio"/>		
Using Slave Terminals with NJ/NX/NY-series Controllers										
Using a Slave Terminal connected to the built-in EtherCAT port					<input type="radio"/>	<input type="radio"/>	<input type="radio"/>			
Specifications of periodic tasks and communications cycles for I/O data exchange with Slave Terminals						<input type="radio"/>				
Specifications of special instructions for Slave Terminals							<input type="radio"/>			
Troubleshooting Slave Terminals										
Troubleshooting Slave Terminals or Communications Coupler Units	<input type="radio"/>									
Troubleshooting NX Units		<input type="radio"/>	<input type="radio"/>	<input type="radio"/>						

Description	System configuration*1									All Units
	(A)EtherCAT Slave Terminal				(B)EtherCAT master				(C)S up-port Soft-ware	
	Communica-tions Coupler Unit/End Cov-er	NX Units			CPU Unit / Industrial PC Hardware User's Manual	CPU Unit / Industrial PC Software User's Manual	CPU Unit / Industrial PC Built-in EtherCAT Port User's Manual	CPU Unit / Industrial PC Instructions Reference Manual		
		NX-series EtherCAT Coupler Unit User's Manual	NX-series System Unit User's Manual	NX-series Safety Control Unit User's Manual					User's manuals for other NX Units	
Performing maintenance for Units on Slave Terminals	○	○	○	○						NX-series Data Reference Manual
										Sysmac Studio Version 1 Operation Manual

\*1. The system configuration is shown below.

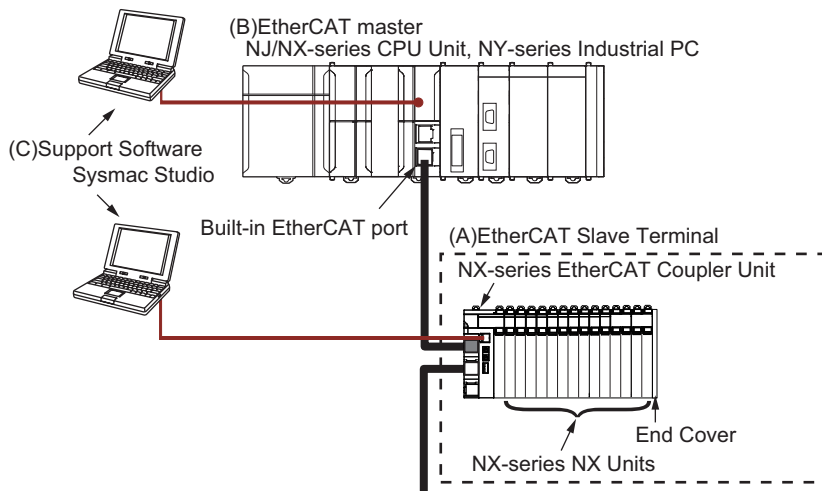

# Manual Structure

## Page Structure

The following page structure is used in this manual.

The diagram illustrates the structure of a manual page, showing various elements and their corresponding annotations:

- Level 1 heading:** 4 Installation and Wiring
- Level 2 heading:** 4-3 Mounting Units
- Level 3 heading:** 4-3-1 Connecting Controller Components
- Gives the current headings:** This label points to the Level 2 and Level 3 headings.
- A step in a procedure:** 1 Join the Units so that the connectors fit exactly.
- Indicates a procedure:** This label points to the numbered step.
- Special information:** Precautions for Correct Use. Icons indicate precautions, additional information, or reference information.
- Page tab:** 4
- Gives the number of the main section:** This label points to the page tab.
- Manual name:** NJ-series CPU Unit Hardware User's Manual (W500)

This illustration is provided only as a sample. It may not literally appear in this manual.

## Special Information

Special information in this manual is classified as follows:



### Precautions for Safe Use

Precautions on what to do and what not to do to ensure safe usage of the product.



### Precautions for Correct Use

Precautions on what to do and what not to do to ensure proper operation and performance.



### Additional Information

Additional information to read as required.

This information is provided to increase understanding or make operation easier.



### Version Information

Information on differences in specifications and functionality for Controller with different unit versions and for different versions of the Sysmac Studio is given.

## Precaution on Terminology

- In this manual, *download* refers to transferring data from the Sysmac Studio to the physical Controller and *upload* refers to transferring data from the physical Controller to the Sysmac Studio. For the Sysmac Studio *synchronization* is used to both *upload* and *download* data. Here *synchronize* means to automatically compare the data for the Sysmac Studio on the computer with the data in the physical Controller and transfer the data in the direction that is specified by the user.
- In this manual, the directions in relation to the Units are given in the following figure, which shows upright installation.

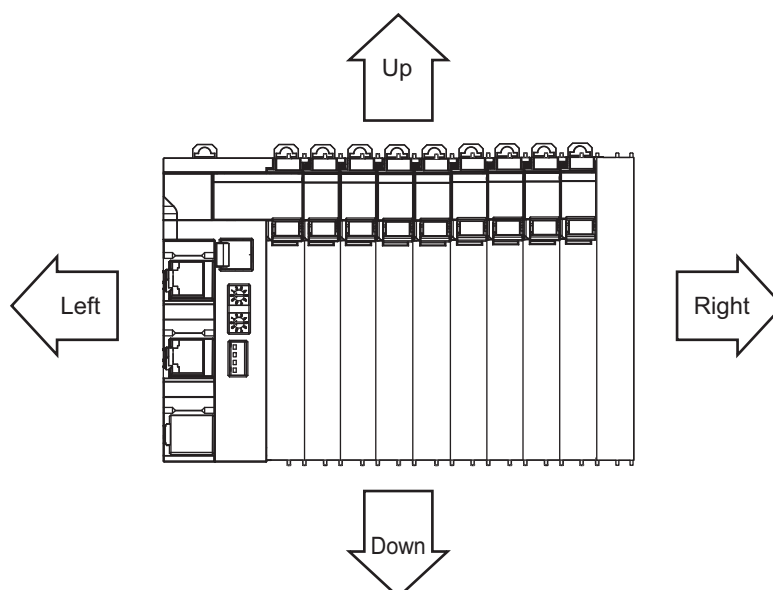

- This user's manual refers to *NY-series IPC Machine Controller Industrial Panel PCs and Industrial Box PCs* as simply *Industrial PCs* or as *NY-series Industrial PCs*.
- This user's manual refers to the *built-in EtherCAT port on an NJ/NX-series Controller or NY-series Industrial PC* as simply a *built-in EtherCAT port*.
- This user's manual may omit manual names and manual numbers in places that refer to the user's manuals for CPU Units and Industrial PCs. The following table gives some examples. When necessary, refer to *Related Manuals* on page 38 to determine the appropriate manual based on the common text for the omitted contents.

Examples:

Manual name	Omitted contents	Common text
NJ/NX-series CPU Unit Software User's Manual	Software user's manual for the connected CPU Unit or Industrial PC	Software User's Manual
NY-series IPC Machine Controller Industrial Panel PC / Industrial Box PC Software User's Manual		
NJ/NX-series CPU Unit Built-in EtherCAT® Port User's Manual	User's manual for built-in EtherCAT port on the connected CPU Unit or Industrial PC	Built-in EtherCAT port
NY-series IPC Machine Controller Industrial Panel PC / Industrial Box PC Built-in EtherCAT® Port User's Manual		



# Sections in this Manual

<b>1</b>	EtherCAT Networks	<b>10</b>	I/O Refreshing	<b>1</b>	<b>10</b>
<b>2</b>	Features and System Configuration	<b>11</b>	EtherCAT Coupler Unit Functions	<b>2</b>	<b>11</b>
<b>3</b>	Specifications and Application Procedures	<b>12</b>	Communications Performance	<b>3</b>	<b>12</b>
<b>4</b>	Part Names and Functions	<b>13</b>	Troubleshooting	<b>4</b>	<b>13</b>
<b>5</b>	Designing the Power Supply System	<b>14</b>	Maintenance and Inspection	<b>5</b>	<b>14</b>
<b>6</b>	Installation	<b>A</b>	Appendices	<b>6</b>	<b>A</b>
<b>7</b>	Wiring	<b>I</b>	Index	<b>7</b>	<b>I</b>
<b>8</b>	EtherCAT Communications			<b>8</b>	
<b>9</b>	Setting Up Slave Terminals			<b>9</b>	

# CONTENTS

---

<b>Introduction .....</b>	<b>1</b>
Intended Audience .....	1
Applicable Products .....	1
<b>Relevant Manuals .....</b>	<b>2</b>
<b>Manual Structure .....</b>	<b>5</b>
Page Structure .....	5
Special Information .....	6
Precaution on Terminology .....	6
<b>Sections in this Manual .....</b>	<b>9</b>
<b>Terms and Conditions Agreement .....</b>	<b>17</b>
Warranty, Limitations of Liability .....	17
Application Considerations .....	18
Disclaimers .....	18
Statement of security responsibilities for assumed use cases and against threats .....	19
<b>Safety Precautions .....</b>	<b>20</b>
Definition of Precautionary Information .....	20
Symbols .....	20
Warnings .....	21
Cautions .....	24
<b>Precautions for Safe Use .....</b>	<b>25</b>
<b>Precautions for Correct Use .....</b>	<b>30</b>
<b>Regulations and Standards .....</b>	<b>32</b>
Conformance to EU Directives .....	32
Conformance to UL and CSA Standards .....	33
Conformance to Shipbuilding Standards .....	33
Conformance to KC Certification .....	33
Software Licenses and Copyrights .....	34
<b>Unit Versions .....</b>	<b>35</b>
Unit Versions .....	35
<b>Related Manuals .....</b>	<b>38</b>
<b>Terminology .....</b>	<b>43</b>
<b>Revision History .....</b>	<b>46</b>

## Section 1 EtherCAT Networks

---

<b>1-1 Introduction to EtherCAT .....</b>	<b>1-2</b>
1-1-1 How EtherCAT Works .....	1-2
1-1-2 Types of EtherCAT Communications .....	1-4
<b>1-2 EtherCAT Network Configuration Elements .....</b>	<b>1-5</b>
1-2-1 System Configuration Example of an EtherCAT Network .....	1-5
1-2-2 Introduction to Configuration Devices .....	1-6

## Section 2 Features and System Configuration

<b>2-1</b>	<b>Features of EtherCAT Slave Terminals</b> .....	<b>2-2</b>
<b>2-2</b>	<b>System Configurations of EtherCAT Slave Terminals</b> .....	<b>2-6</b>
2-2-1	System Configuration .....	2-6
2-2-2	Types of NX Units .....	2-8
2-2-3	Safety Control System .....	2-9
<b>2-3</b>	<b>Support Software</b> .....	<b>2-10</b>
2-3-1	Applicable Support Software .....	2-10
2-3-2	Connection Method and Procedures .....	2-10
2-3-3	Scope of Access When Connected to the USB Port on the EtherCAT Coupler Unit .....	2-12

## Section 3 Specifications and Application Procedures

<b>3-1</b>	<b>Specifications</b> .....	<b>3-2</b>
3-1-1	General Specifications of EtherCAT Slave Terminals .....	3-2
3-1-2	EtherCAT Coupler Unit Specifications.....	3-2
3-1-3	End Cover Specifications .....	3-6
<b>3-2</b>	<b>Procedures</b> .....	<b>3-7</b>
3-2-1	EtherCAT Slave Terminal Application Procedures .....	3-7
3-2-2	Details .....	3-9

## Section 4 Part Names and Functions

<b>4-1</b>	<b>Parts and Names</b> .....	<b>4-2</b>
4-1-1	EtherCAT Coupler Units .....	4-2
4-1-2	NX Units .....	4-4
4-1-3	End Cover .....	4-5
<b>4-2</b>	<b>Indicators</b> .....	<b>4-6</b>
<b>4-3</b>	<b>Hardware Switch Settings</b> .....	<b>4-11</b>
4-3-1	Rotary Switches .....	4-11
4-3-2	DIP Switch.....	4-12
4-3-3	Setting the Node Address .....	4-13
<b>4-4</b>	<b>Communications Connector and Peripheral USB Port</b> .....	<b>4-14</b>
<b>4-5</b>	<b>Terminal Blocks</b> .....	<b>4-15</b>
<b>4-6</b>	<b>DIN Track Contact Plate</b> .....	<b>4-17</b>

## Section 5 Designing the Power Supply System

<b>5-1</b>	<b>Power Supply System and Design Concepts</b> .....	<b>5-2</b>
5-1-1	Power Supply System and Types of Power Supplies .....	5-2
5-1-2	NX-series Power Supply-related Units.....	5-3
5-1-3	Design Concepts for Power Supply to the EtherCAT Slave Terminal .....	5-5
<b>5-2</b>	<b>Designing the NX Unit Power Supply System</b> .....	<b>5-6</b>
5-2-1	Procedure for Designing the NX Unit Power Supply System .....	5-6
5-2-2	Calculation Example for the NX Unit Power Supply.....	5-7
<b>5-3</b>	<b>Designing the I/O Power Supply System</b> .....	<b>5-9</b>
5-3-1	I/O Power Supply Method .....	5-9
5-3-2	Designing the I/O Power Supply from the NX Bus.....	5-10
5-3-3	Designing the I/O Power Supply from External Sources.....	5-14
5-3-4	Restrictions on Inrush Current for ON/OFF Operation .....	5-14
<b>5-4</b>	<b>Selecting External Power Supplies and Protective Devices</b> .....	<b>5-16</b>

5-4-1	Selecting the Unit Power Supply .....	5-16
5-4-2	Selecting the I/O Power Supplies .....	5-18
5-4-3	Selecting Protective Devices .....	5-20

## Section 6 Installation

<b>6-1</b>	<b>Installing Units .....</b>	<b>6-2</b>
6-1-1	Installation Precautions .....	6-2
6-1-2	Preparations for Installation .....	6-6
6-1-3	Installation Orientation .....	6-8
6-1-4	Installing the EtherCAT Coupler Unit.....	6-9
6-1-5	Installing and Connecting NX Units.....	6-11
6-1-6	Mounting the End Cover .....	6-14
6-1-7	Mounting the End Plates .....	6-16
6-1-8	Attaching Markers .....	6-18
6-1-9	Removing Units .....	6-19
6-1-10	Assembled Appearance and Dimensions .....	6-20
<b>6-2</b>	<b>Control Panel Installation.....</b>	<b>6-24</b>
6-2-1	Temperature .....	6-24
6-2-2	Humidity .....	6-25
6-2-3	Vibration and Shock .....	6-26
6-2-4	Atmosphere .....	6-26
6-2-5	Electrical Environment .....	6-26
6-2-6	Grounding .....	6-31

## Section 7 Wiring

<b>7-1</b>	<b>EtherCAT Network Wiring .....</b>	<b>7-2</b>
7-1-1	Installation Precautions .....	7-2
7-1-2	Preparations for Installation .....	7-2
7-1-3	Pin Arrangement of Communications Connectors on the EtherCAT Coupler Unit.....	7-4
7-1-4	Connecting Communications Cables and Connectors.....	7-5
7-1-5	Connecting Communications Cables .....	7-5
<b>7-2</b>	<b>Connecting the Power Supply and Ground Wires .....</b>	<b>7-7</b>
7-2-1	Wiring the EtherCAT Coupler Unit.....	7-7
7-2-2	Wiring the Power Supply to the EtherCAT Slave Terminal.....	7-8
7-2-3	Grounding the EtherCAT Slave Terminal .....	7-8
7-2-4	Precautions for Wiring the EtherCAT Slave Terminal Together with Computers and Other Peripheral Devices .....	7-12
7-2-5	Wiring to the Screwless Clamping Terminal Block .....	7-13
<b>7-3</b>	<b>Connecting USB Cable.....</b>	<b>7-27</b>
<b>7-4</b>	<b>Wiring External Signal Lines .....</b>	<b>7-29</b>

## Section 8 EtherCAT Communications

<b>8-1</b>	<b>Structure of CAN Application Protocol over EtherCAT (CoE) .....</b>	<b>8-2</b>
<b>8-2</b>	<b>EtherCAT Slave Information Files (ESI Files).....</b>	<b>8-3</b>
<b>8-3</b>	<b>Transitions of Communications States .....</b>	<b>8-4</b>
<b>8-4</b>	<b>Process Data Objects (PDOs).....</b>	<b>8-5</b>
8-4-1	Introduction .....	8-5
8-4-2	PDO Mappings .....	8-6
8-4-3	Assigning PDOs .....	8-8
<b>8-5</b>	<b>Service Data Objects (SDOs) .....</b>	<b>8-9</b>
8-5-1	Introduction .....	8-9
8-5-2	Abort Codes .....	8-9

<b>8-6</b>	<b>Communications between an EtherCAT Master and Slaves</b> .....	<b>8-10</b>
8-6-1	Communications Modes for Communications between an EtherCAT Master and Slaves .....	8-10
8-6-2	Communications Modes for EtherCAT Slave Terminals .....	8-10
8-6-3	Communications Cycle .....	8-10

## Section 9 Setting Up Slave Terminals

<b>9-1</b>	<b>Settings and Setting Procedures</b> .....	<b>9-2</b>
9-1-1	Items to Set .....	9-2
9-1-2	Slave Terminal Parameters .....	9-2
9-1-3	Variable Assignment Settings .....	9-3
9-1-4	Setting Procedures .....	9-3
<b>9-2</b>	<b>Setting Slave Terminal Parameters</b> .....	<b>9-5</b>
9-2-1	Items to Set .....	9-5
9-2-2	Settings as an EtherCAT Slave .....	9-7
9-2-3	Setting the Unit Configuration Information .....	9-10
9-2-4	I/O Allocation Information .....	9-15
9-2-5	Unit Operation Settings .....	9-26
9-2-6	Unit Application Data .....	9-28
9-2-7	Sysmac Studio Functions Used as Required .....	9-28
<b>9-3</b>	<b>Assigning Variables</b> .....	<b>9-37</b>
9-3-1	Methods to Assign Variables .....	9-37
9-3-2	Assigning Device Variables to I/O Ports .....	9-38
9-3-3	I/O Ports for Status That Accept Device Variable Assignments .....	9-39
9-3-4	Assigning Axis Variables .....	9-40
<b>9-4</b>	<b>Transferring and Comparing Settings</b> .....	<b>9-42</b>
9-4-1	Transferring Settings .....	9-42
9-4-2	Comparing Settings .....	9-45
<b>9-5</b>	<b>Backing Up Settings</b> .....	<b>9-47</b>
9-5-1	Backup Functions .....	9-47
9-5-2	SD Memory Card Backup Function .....	9-47
9-5-3	Sysmac Studio Controller Backup Function .....	9-48
9-5-4	Data That Is Backed Up .....	9-48
9-5-5	Backing Up the Slave Terminal Settings by Transferring Data .....	9-48
<b>9-6</b>	<b>Precautions in Changing the Unit Configuration</b> .....	<b>9-51</b>
9-6-1	I/O Data That Require Specification of NX Unit Numbers .....	9-51
9-6-2	NX Bus Refresh Cycle in DC Mode .....	9-52
9-6-3	Using Settings from NX Units on Other Slave Terminals .....	9-53
9-6-4	Transferring Slave Terminal Setting Information to the Controller .....	9-53

## Section 10 I/O Refreshing

<b>10-1</b>	<b>Introduction to I/O Refreshing for EtherCAT Slave Terminals</b> .....	<b>10-2</b>
<b>10-2</b>	<b>I/O Refreshing for EtherCAT Slaves</b> .....	<b>10-6</b>
10-2-1	I/O Refreshing Modes .....	10-6
10-2-2	I/O Refreshing Mode Operation .....	10-6
<b>10-3</b>	<b>I/O Refreshing for EtherCAT Slave Terminals</b> .....	<b>10-8</b>
10-3-1	I/O Refreshing Methods .....	10-8
10-3-2	Setting the I/O Refreshing Methods .....	10-9
10-3-3	Selecting NX Units .....	10-10
10-3-4	I/O Refreshing Method Operation .....	10-10
10-3-5	Setting the Task Periods of Periodic Tasks .....	10-18
10-3-6	Task Allocations .....	10-22

## Section 11 EtherCAT Coupler Unit Functions

<b>11-1</b>	<b>Functions</b> .....	<b>11-3</b>
<b>11-2</b>	<b>NX Unit Mounting Settings</b> .....	<b>11-6</b>
11-2-1	Introduction .....	11-6
11-2-2	Applications.....	11-7
11-2-3	Operating Specifications for NX Units That Are Set as Unmounted Units .....	11-8
11-2-4	Setting NX Units as Unmounted Units .....	11-9
<b>11-3</b>	<b>Symac Device Functionality Unique to EtherCAT Slaves</b> .....	<b>11-11</b>
<b>11-4</b>	<b>Security</b> .....	<b>11-13</b>
11-4-1	Supported Security Functions .....	11-13
11-4-2	Specifications of Verification of Operation Authority for the EtherCAT Slave Terminal .....	11-13
<b>11-5</b>	<b>Event Logs</b> .....	<b>11-15</b>
11-5-1	Introduction .....	11-15
11-5-2	Detailed Information on Event Logs .....	11-16
11-5-3	Reading Event Logs .....	11-19
11-5-4	Clearing Event Logs .....	11-20
11-5-5	Exporting the Event Log .....	11-22
<b>11-6</b>	<b>Clearing All Memory</b> .....	<b>11-23</b>
11-6-1	Introduction .....	11-23
11-6-2	Details on Clearing All Memory .....	11-23
11-6-3	Procedure for Clearing All Memory .....	11-24
<b>11-7</b>	<b>Restarting</b> .....	<b>11-26</b>
11-7-1	Introduction .....	11-26
11-7-2	Details on Restarting .....	11-26
11-7-3	Procedure for Restarting .....	11-27
<b>11-8</b>	<b>Changing Event Levels</b> .....	<b>11-29</b>
11-8-1	Introduction .....	11-29
11-8-2	Details on Changing Event Levels .....	11-29
11-8-3	Procedure to Change an Event Level .....	11-29
<b>11-9</b>	<b>Resetting Errors</b> .....	<b>11-31</b>
11-9-1	Introduction .....	11-31
11-9-2	Details on Resetting Errors .....	11-31
11-9-3	Procedure to Reset Errors .....	11-32
<b>11-10</b>	<b>I/O Checking</b> .....	<b>11-35</b>
11-10-1	Overview .....	11-35
11-10-2	Details on I/O Checking .....	11-35
11-10-3	Procedure Required before I/O Checking .....	11-37
11-10-4	I/O Checking Operating Procedure .....	11-39
<b>11-11</b>	<b>Fail-soft Operation</b> .....	<b>11-41</b>
11-11-1	Overview .....	11-41
11-11-2	Application.....	11-42
11-11-3	Details on Fail-soft Operation.....	11-42
<b>11-12</b>	<b>Prohibiting USB Connections</b> .....	<b>11-45</b>
11-12-1	Overview .....	11-45
11-12-2	Details on Prohibiting USB Connections.....	11-45
<b>11-13</b>	<b>Monitoring Total Power-ON Time</b> .....	<b>11-47</b>
11-13-1	Overview .....	11-47
11-13-2	Details on Monitoring Total Power-ON Times .....	11-47
11-13-3	Checking Total Power-ON Times .....	11-47

## Section 12 Communications Performance

<b>12-1</b>	<b>Performance of Process Data Communications</b> .....	<b>12-2</b>
12-1-1	I/O Response Times for Synchronous I/O Refreshing .....	12-2

12-1-2	I/O Response Times for Task Period Prioritized Refreshing .....	12-16
12-1-3	I/O Response Times for Time Stamp Refreshing .....	12-23
12-1-4	I/O Response Times for Free-Run Refreshing .....	12-27
<b>12-2</b>	<b>Message Response Time .....</b>	<b>12-36</b>
12-2-1	Special Instructions .....	12-36
12-2-2	Minimum Message Response Time .....	12-36

## Section 13 Troubleshooting

<b>13-1</b>	<b>How to Check for Errors.....</b>	<b>13-2</b>
<b>13-2</b>	<b>Checking for Errors and Troubleshooting with the Indicators.....</b>	<b>13-3</b>
13-2-1	Checking for Errors and Troubleshooting with the Indicators on the EtherCAT Coupler Unit ...	13-3
13-2-2	Checking for Errors and Troubleshooting with the Indicators on the NX Units .....	13-11
<b>13-3</b>	<b>Checking for Errors and Troubleshooting on the Sysmac Studio.....</b>	<b>13-12</b>
13-3-1	Checking for Errors from the Sysmac Studio .....	13-12
13-3-2	Event Codes for Errors and Troubleshooting Procedures.....	13-14
<b>13-4</b>	<b>Resetting Errors.....</b>	<b>13-53</b>
<b>13-5</b>	<b>Error Notification Methods.....</b>	<b>13-54</b>
<b>13-6</b>	<b>Error Notifications Based on the Sysmac Error Status .....</b>	<b>13-55</b>
<b>13-7</b>	<b>Emergency Messages .....</b>	<b>13-56</b>
13-7-1	Enabling/Disabling Emergency Message Notification .....	13-56
13-7-2	Error Logs .....	13-56
13-7-3	Emergency Error Codes.....	13-57
<b>13-8</b>	<b>Error Notifications Based on the AL Status .....</b>	<b>13-60</b>
13-8-1	Procedure for Checking AL Status Codes .....	13-60
13-8-2	AL Status Codes .....	13-60
<b>13-9</b>	<b>Troubleshooting Other Errors .....</b>	<b>13-64</b>
<b>13-10</b>	<b>Troubleshooting Flow When Errors Occur.....</b>	<b>13-65</b>
13-10-1	When the Sysmac Studio Is Connected to a CPU Unit or an Industrial PC .....	13-65
13-10-2	When the Sysmac Studio Is Connected to the EtherCAT Coupler Unit.....	13-66
<b>13-11</b>	<b>Troubleshooting When the Sysmac Studio Cannot Go Online .....</b>	<b>13-68</b>
13-11-1	Causes and Corrective Actions When the Sysmac Studio Cannot Go Online.....	13-68
13-11-2	Troubleshooting by Cause .....	13-69

## Section 14 Maintenance and Inspection

<b>14-1</b>	<b>Cleaning and Maintenance.....</b>	<b>14-2</b>
14-1-1	Cleaning .....	14-2
14-1-2	Periodic Inspections .....	14-2
<b>14-2</b>	<b>Maintenance Procedures .....</b>	<b>14-5</b>
14-2-1	Backing Up Data .....	14-5
14-2-2	Replacement Procedure for the EtherCAT Coupler Unit.....	14-5
14-2-3	Basic Replacement Procedure for NX Units .....	14-7

## Appendices

<b>A-1</b>	<b>Dimensions.....</b>	<b>A-3</b>
A-1-1	EtherCAT Coupler Unit.....	A-3
A-1-2	End Cover .....	A-4
<b>A-2</b>	<b>Supplementary Information on Sysmac Studio Functions.....</b>	<b>A-5</b>
A-2-1	Functional Differences on the Sysmac Studio Based on the Connected Port .....	A-5
A-2-2	Transferring the Unit Operation Settings.....	A-6

A-2-3	Transferring Slave Terminal Setting Information through the USB Port on the EtherCAT Coupler Unit .....	A-8
<b>A-3</b>	<b>Special Instructions.....</b>	<b>A-10</b>
A-3-1	Instructions.....	A-10
A-3-2	Specifying the Targets for Instructions .....	A-11
<b>A-4</b>	<b>Connecting to Masters from Other Manufacturers.....</b>	<b>A-12</b>
A-4-1	Basic Connection Procedures .....	A-12
A-4-2	Supplementary Information for Connections with a Master from Another Manufacturer .....	A-13
<b>A-5</b>	<b>Troubleshooting with a Master from Another Manufacturer .....</b>	<b>A-18</b>
A-5-1	CoE Objects Used for Troubleshooting.....	A-18
A-5-2	Getting Information on Current Errors in EtherCAT Coupler Units and NX Units.....	A-18
A-5-3	Clearing Current Errors in EtherCAT Coupler Units and NX Units.....	A-19
A-5-4	Getting Event Logs from EtherCAT Coupler Units and NX Units.....	A-19
A-5-5	Clearing Event Logs from EtherCAT Coupler Units and NX Units .....	A-20
A-5-6	Troubleshooting Procedure .....	A-20
<b>A-6</b>	<b>Setting NX Unit Operation Settings with a Master from Another Manufacturer .....</b>	<b>A-22</b>
A-6-1	Difference between Using CoE Objects for Saving Parameters and Those for Initializing Parameters.....	A-22
A-6-2	Unit Operation Settings When Using Index 1010 Hex (Store Parameters).....	A-23
A-6-3	Unit Operation Settings When Using Index 380F Hex (Store Parameters Command).....	A-24
A-6-4	Unit Operation Settings When Using Index 1011 Hex (Restore Default Parameters).....	A-26
A-6-5	Unit Operation Settings When Using Index 3810 Hex (Restore Default Parameters Command) .....	A-28
<b>A-7</b>	<b>CoE Objects.....</b>	<b>A-31</b>
A-7-1	Object Dictionary Area .....	A-31
A-7-2	Data Type .....	A-31
A-7-3	Assigning Objects .....	A-32
A-7-4	Format of Objects.....	A-34
A-7-5	Communication Objects .....	A-35
A-7-6	PDO Mapping Objects .....	A-43
A-7-7	Sync Manager Communications Objects .....	A-52
A-7-8	Manufacturer-specific Object 1 .....	A-57
A-7-9	Manufacturer-specific Object 2 .....	A-61
A-7-10	Device Profile Area .....	A-81
A-7-11	Modular Device-specific Area .....	A-86
<b>A-8</b>	<b>NX Objects.....</b>	<b>A-89</b>
A-8-1	NX Objects .....	A-89
A-8-2	Format of Object Descriptions.....	A-89
A-8-3	Unit Information Object .....	A-90
A-8-4	Objects That Accept I/O Allocations.....	A-92
A-8-5	Other Objects .....	A-95
<b>A-9</b>	<b>Terminal Block Model Numbers .....</b>	<b>A-100</b>
A-9-1	Model Number Notation .....	A-100
A-9-2	Models.....	A-100
<b>A-10</b>	<b>Functional Restrictions by Model .....</b>	<b>A-101</b>
<b>A-11</b>	<b>Version Information .....</b>	<b>A-102</b>
A-11-1	Relationship between Unit Versions.....	A-102
A-11-2	Functions That Were Added or Changed for Each Unit Version.....	A-103

## Index

---

# Terms and Conditions Agreement

---

## Warranty, Limitations of Liability

### Warranties

---

- **Exclusive Warranty**

Omron's exclusive warranty is that the Products will be free from defects in materials and workmanship for a period of twelve months from the date of sale by Omron (or such other period expressed in writing by Omron). Omron disclaims all other warranties, express or implied.

- **Limitations**

OMRON MAKES NO WARRANTY OR REPRESENTATION, EXPRESS OR IMPLIED, ABOUT NON-INFRINGEMENT, MERCHANTABILITY OR FITNESS FOR A PARTICULAR PURPOSE OF THE PRODUCTS. BUYER ACKNOWLEDGES THAT IT ALONE HAS DETERMINED THAT THE PRODUCTS WILL SUITABLY MEET THE REQUIREMENTS OF THEIR INTENDED USE.

Omron further disclaims all warranties and responsibility of any type for claims or expenses based on infringement by the Products or otherwise of any intellectual property right.

- **Buyer Remedy**

Omron's sole obligation hereunder shall be, at Omron's election, to (i) replace (in the form originally shipped with Buyer responsible for labor charges for removal or replacement thereof) the non-complying Product, (ii) repair the non-complying Product, or (iii) repay or credit Buyer an amount equal to the purchase price of the non-complying Product; provided that in no event shall Omron be responsible for warranty, repair, indemnity or any other claims or expenses regarding the Products unless Omron's analysis confirms that the Products were properly handled, stored, installed and maintained and not subject to contamination, abuse, misuse or inappropriate modification. Return of any Products by Buyer must be approved in writing by Omron before shipment. Omron Companies shall not be liable for the suitability or unsuitability or the results from the use of Products in combination with any electrical or electronic components, circuits, system assemblies or any other materials or substances or environments. Any advice, recommendations or information given orally or in writing, are not to be construed as an amendment or addition to the above warranty.

See <https://www.omron.com/global/> or contact your Omron representative for published information.

### Limitation on Liability; Etc

---

OMRON COMPANIES SHALL NOT BE LIABLE FOR SPECIAL, INDIRECT, INCIDENTAL, OR CONSEQUENTIAL DAMAGES, LOSS OF PROFITS OR PRODUCTION OR COMMERCIAL LOSS IN ANY

WAY CONNECTED WITH THE PRODUCTS, WHETHER SUCH CLAIM IS BASED IN CONTRACT, WARRANTY, NEGLIGENCE OR STRICT LIABILITY.

Further, in no event shall liability of Omron Companies exceed the individual price of the Product on which liability is asserted.

## Application Considerations

### Suitability of Use

Omron Companies shall not be responsible for conformity with any standards, codes or regulations which apply to the combination of the Product in the Buyer's application or use of the Product. At Buyer's request, Omron will provide applicable third party certification documents identifying ratings and limitations of use which apply to the Product. This information by itself is not sufficient for a complete determination of the suitability of the Product in combination with the end product, machine, system, or other application or use. Buyer shall be solely responsible for determining appropriateness of the particular Product with respect to Buyer's application, product or system. Buyer shall take application responsibility in all cases.

NEVER USE THE PRODUCT FOR AN APPLICATION INVOLVING SERIOUS RISK TO LIFE OR PROPERTY OR IN LARGE QUANTITIES WITHOUT ENSURING THAT THE SYSTEM AS A WHOLE HAS BEEN DESIGNED TO ADDRESS THE RISKS, AND THAT THE OMRON PRODUCT(S) IS PROPERLY RATED AND INSTALLED FOR THE INTENDED USE WITHIN THE OVERALL EQUIPMENT OR SYSTEM.

### Programmable Products

Omron Companies shall not be responsible for the user's programming of a programmable Product, or any consequence thereof.

## Disclaimers

### Performance Data

Data presented in Omron Company websites, catalogs and other materials is provided as a guide for the user in determining suitability and does not constitute a warranty. It may represent the result of Omron's test conditions, and the user must correlate it to actual application requirements. Actual performance is subject to the Omron's Warranty and Limitations of Liability.

### Change in Specifications

Product specifications and accessories may be changed at any time based on improvements and other reasons. It is our practice to change part numbers when published ratings or features are changed, or when significant construction changes are made. However, some specifications of the Product may

be changed without any notice. When in doubt, special part numbers may be assigned to fix or establish key specifications for your application. Please consult with your Omron's representative at any time to confirm actual specifications of purchased Product.

## **Errors and Omissions**

---

Information presented by Omron Companies has been checked and is believed to be accurate; however, no responsibility is assumed for clerical, typographical or proofreading errors or omissions.

## **Statement of security responsibilities for assumed use cases and against threats**

OMRON SHALL NOT BE RESPONSIBLE AND/OR LIABLE FOR ANY LOSS, DAMAGE, OR EXPENSES DIRECTLY OR INDIRECTLY RESULTING FROM THE INFECTION OF OMRON PRODUCTS, ANY SOFTWARE INSTALLED THEREON OR ANY COMPUTER EQUIPMENT, COMPUTER PROGRAMS, NETWORKS, DATABASES OR OTHER PROPRIETARY MATERIAL CONNECTED THERETO BY DISTRIBUTED DENIAL OF SERVICE ATTACK, COMPUTER VIRUSES, OTHER TECHNOLOGICALLY HARMFUL MATERIAL AND/OR UNAUTHORIZED ACCESS.

It shall be the users sole responsibility to determine and use adequate measures and checkpoints to satisfy the users particular requirements for (i) antivirus protection, (ii) data input and output, (iii) maintaining a means for reconstruction of lost data, (iv) preventing Omron Products and/or software installed thereon from being infected with computer viruses and (v) protecting Omron Products from unauthorized access.



# Safety Precautions

## Definition of Precautionary Information





The following notation is used in this manual to provide precautions required to ensure safe usage of the NX-series EtherCAT Coupler Unit.

The safety precautions that are provided are extremely important to safety. Always read and heed the information provided in all safety precautions.

The following notation is used.

 <b>WARNING</b>	<p>Indicates a potentially hazardous situation which, if not avoided, could result in death or serious injury. Additionally, there may be severe property damage.</p>
 <b>Caution</b>	<p>Indicates a potentially hazardous situation which, if not avoided, may result in minor or moderate injury, or property damage.</p>

## Symbols

	<p>The circle and slash symbol indicates operations that you must not do. The specific operation is shown in the circle and explained in text. This example indicates prohibiting disassembly.</p>
	<p>The triangle symbol indicates precautions (including warnings). The specific operation is shown in the triangle and explained in text. This example indicates a precaution for electric shock.</p>
	<p>The triangle symbol indicates precautions (including warnings). The specific operation is shown in the triangle and explained in text. This example indicates a general precaution.</p>
	<p>The filled circle symbol indicates operations that you must do. The specific operation is shown in the circle and explained in text. This example shows a general precaution for something that you must do.</p>

## Warnings

### WARNING

#### During Power Supply

Do not touch the terminal section while power is ON.  
Electric shock may occur.



Do not attempt to take any Unit apart.  
In particular, high-voltage parts are present in Units that supply power while power is supplied or immediately after power is turned OFF. Touching any of these parts may result in electric shock. There are sharp parts inside the Unit that may cause injury.



#### Fail-safe Measures

Provide safety measures in external circuits to ensure safety in the system if an abnormality occurs due to malfunction of the CPU Unit, Industrial PC, other Units, or slaves or due to other external factors affecting operation.  
Not doing so may result in serious accidents due to incorrect operation.



Emergency stop circuits, interlock circuits, limit circuits, and similar safety measures must be provided in external control circuits.



The CPU Unit or Industrial PC will turn OFF all outputs from Output Units in the following cases. The remote I/O slaves will operate according to the settings in the slaves.

- If a power supply error occurs.
- If the power supply connection becomes faulty.
- If a CPU watchdog timer error or CPU reset occurs.
- If a Controller error in the major fault level occurs.
- While the CPU Unit is on standby until RUN mode is entered after the power is turned ON



External safety measures must be provided to ensure safe operation of the system in such cases.

The outputs may remain ON or OFF due to deposition or burning of the output relays or destruction of the output transistors. As a countermeasure for such problems, external safety measures must be provided to ensure safe operation of the system.



If external power supplies for slaves or other devices are overloaded or short-circuited, the voltage will drop, outputs will turn OFF, and the system may be unable to read inputs. Provide external safety measures in control with monitoring of external power supply voltage as required so that the system operates safely in such a case.



You must take fail-safe measures to ensure safety in the event of incorrect, missing, or abnormal signals caused by broken signal lines, momentary power interruptions, or other causes.



Not doing so may result in serious accidents due to incorrect operation.

## Voltage and Current Inputs

Make sure that the voltages and currents that are input to the Units and slaves are within the specified ranges.

Inputting voltages or currents that are outside of the specified ranges may cause accidents or fire.



## Transferring

Always confirm safety at the destination node before you transfer Unit configuration information, parameters, settings, or other data from tools such as the Sysmac Studio.

The devices or machines may operate unexpectedly, regardless of the operating mode of the Controller.



## Security Measures

### Anti-virus protection

Install the latest commercial-quality antivirus software on the computer connected to the control system and maintain to keep the software up-to-date.



### Security measures to prevent unauthorized access

Take the following measures to prevent unauthorized access to our products.

- Install physical controls so that only authorized personnel can access control systems and equipment.
- Reduce connections to control systems and equipment via networks to prevent access from untrusted devices.
- Install firewalls to shut down unused communications ports and limit communications hosts and isolate control systems and equipment from the IT network.
- Use a virtual private network (VPN) for remote access to control systems and equipment.
- Adopt multifactor authentication to devices with remote access to control systems and equipment.
- Set strong passwords and change them frequently.
- Scan virus to ensure safety of USB drives or other external storages before connecting them to control systems and equipment.



### Data input and output protection

Validate backups and ranges to cope with unintentional modification of input/output data to control systems and equipment.

- Checking the scope of data
- Checking validity of backups and preparing data for restore in case of falsification and abnormalities
- Safety design, such as emergency shutdown and fail-soft operation in case of data tampering and abnormalities



### Data recovery

Backup data and keep the data up-to-date periodically to prepare for data loss.



When using an intranet environment through a global address, connecting to a SCADA or an unauthorized terminal such as an HMI or to an unauthorized server may result in network security issues such as spoofing and tampering. You must take sufficient measures such as restricting access to the terminal, using a terminal equipped with a secure function, and locking the installation area by yourself.



---

When constructing an intranet, communication failure may occur due to cable disconnection or the influence of unauthorized network equipment. Take adequate measures, such as restricting physical access to network devices, by means such as locking the installation area.



---

When using a device equipped with the SD Memory Card function, there is a security risk that a third party may acquire, alter, or replace the files and data in the removable media by removing the removable media or unmounting the removable media. Please take sufficient measures, such as restricting physical access to the Controller or taking appropriate management measures for removable media, by means of locking the installation area, entrance management, etc., by yourself.

---



## Cautions

### ⚠ Caution

#### Wiring

When you connect a computer or other peripheral device to a Communications Coupler Unit that has a non-isolated DC power supply, either ground the 0-V side of the external power supply (i.e. Unit power supply) or do not ground it at all.

If the peripheral devices are grounded incorrectly, the external power supply (i.e. Unit power supply) may be short-circuited.

Never ground the 24-V side of the power supply, as shown in the following figure.

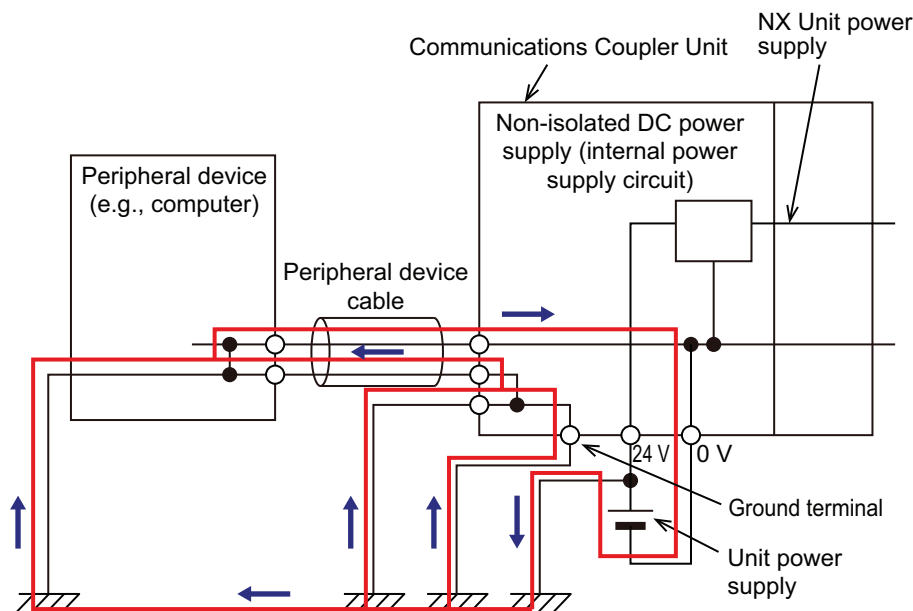

Be sure that all terminal screws and cable connector screws are tightened to the torque specified in the relevant manuals. The loose screws may result in fire or malfunction.



#### Online Editing

Execute online editing only after confirming that no adverse effects will be caused by deviations in the timing of I/O. If you perform online editing, the task execution time may exceed the task period, I/O may not be refreshed with external devices, input signals may not be read, and output timing may change.



# Precautions for Safe Use

## Transporting

- When transporting any Unit, use the special packing box for it.  
Also, do not subject the Unit to excessive vibration or shock during transportation.
- Do not drop any Unit or subject it to abnormal vibration or shock.  
Doing so may result in Unit malfunction or burning.

## Mounting

- Mount terminal blocks and connectors only after checking the mounting location carefully.
- Be sure that the terminal blocks, expansion cables, and other items with locking devices are properly locked into place.

## Installation

- Always turn OFF the power supply before installing the Unit. If the power supply is not OFF, the Unit may malfunction or may be damaged.
- Always turn OFF the Unit power supply and I/O power supply before you remove the NX Unit.
- Do not apply labels or tape to the Unit. When the Unit is installed or removed, adhesive or scraps may adhere to the pins in the NX bus connector, which may result in malfunctions.
- Do not touch the pins in the NX bus connector on the Unit. Dirt may adhere to the pins in the NX bus connector, which may result in malfunctions.

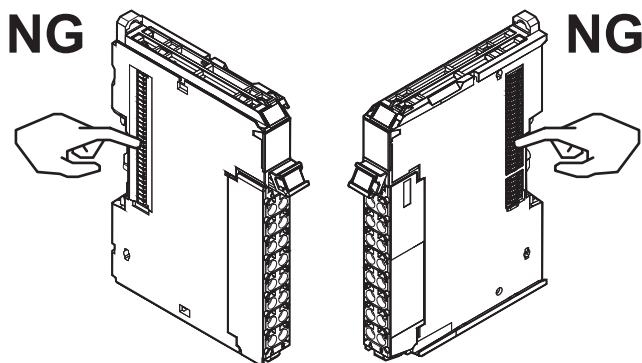

Example: NX Unit (12 mm width)

- Do not write on the Communications Coupler Unit or an NX Unit with ink within the restricted region that is shown in the following figure. Also do not get this area dirty. When the Unit is installed or removed, ink or dirt may adhere to the pins in the NX bus connector, which may result in malfunctions in the Slave Terminal.

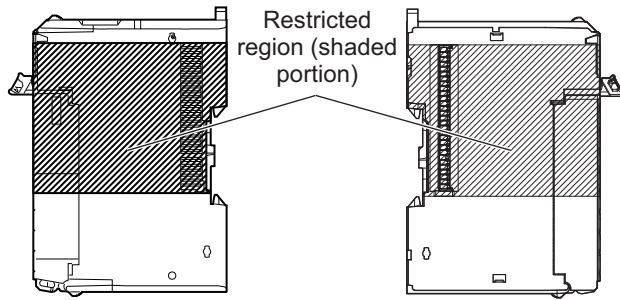

- For the installation orientations in the following figure, support the cables, e.g., with a duct, so that the End Plate on the bottom is not subjected to the weight of the cables. The weight of the cables may cause the bottom End Plate to slide downward so that the Slave Terminal is no longer secured to the DIN Track, which may result in malfunctions.

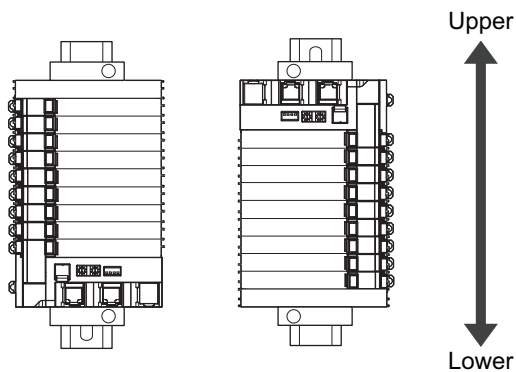

## Wiring

- Double-check all switches and other settings and double-check all wiring to make sure that they are correct before turning ON the power supply.
- Use the correct wiring parts and tools when you wire the system.
- Do not pull on the cables or bend the cables beyond their natural limit. Also, do not place heavy objects on top of the cables or other wiring lines. Doing so may break the cable.
- When wiring or installing the Units, do not allow metal fragments to enter the Units.
- Do not press the flat-blade screwdriver straight into the release holes on a screwless clamping terminal block. Doing so may damage the terminal block.

**NG**

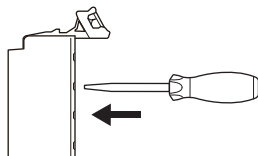

**OK**

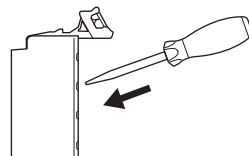

- When you insert a flat-blade screwdriver into a release hole on a screwless clamping terminal block, press it down with a force of 30N or less. Applying excessive force may damage the terminal block.
- Do not incline or twist the flat-blade screwdriver while it is in a release hole on a screwless clamping terminal block. Doing so may damage the terminal block.

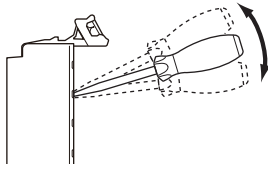
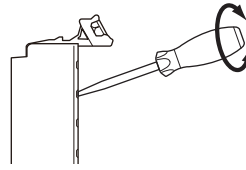
**NG****NG**

- Use crimp terminals for wiring the M3 screw terminal blocks. Do not connect bare stranded wires directly to the M3 screw terminal blocks.

## Power Supply Design

- Use all Units within the I/O power supply ranges that are given in the specifications.
- Supply sufficient power according to the contents of this manual.
- Use the power supply voltage that is specified in this manual.
- Do not apply voltages that exceed the rated value to any Input Unit.
- Do not apply voltages or connect loads to the Output Units or slaves in excess of the maximum ratings.
- Inrush current occurs when the power supply is turned ON. When selecting fuses or breakers for external circuits, consider their fusing and detection characteristics as well as the above precautions and allow sufficient margin in shut-off performance.
- Install external breakers and take other safety measures against short-circuiting and overcurrents in external wiring.

## Turning ON the Power Supply

- When you set the Operating Mode at Startup, confirm that no adverse effect will occur in the system.

## Actual Operation

- Before you start operation, always register the NX Units that are connected to the Communications Coupler Unit in the host communications master as the Unit Configuration Information.
- Check the user program, data, and parameter settings for proper execution before you use them for actual operation.
- If you change the fail-soft operation setting, the output status when the error occurs may also change. Confirm safety before you change the fail-soft operation setting.
- If you use fail-soft operation, write programming to determine whether Unit I/O data is valid. Without such programming, the user program cannot distinguish between Units for which I/O refreshing is continued and Units for which I/O refreshing is stopped.

## Turning OFF the Power Supply

- Do not disconnect the cable or turn OFF the power supply to the Controller or a Slave Terminal when downloading data or the user program from the Support Software.

- Always turn OFF the external power supply to the Units before attempting any of the following.
  - a) Mounting or removing an NX Unit, Communications Coupler Unit, CPU Unit, Industrial PC, or Communication Control Unit
  - b) Assembling Units
  - c) Setting DIP switches or rotary switches
  - d) Connecting or wiring cables
  - e) Attaching or removing terminal blocks or connectors

Units that supply power continue to supply power to the Units for up to several seconds after the power supply is turned OFF. The PWR indicator remains lit as long as power is supplied. Confirm that the PWR indicator is not lit before you perform any of the above.

## Operation

---

- Confirm that the controlled system will not be adversely affected before you perform any of the following operations.
  - a) Changing the operating mode of the CPU Unit or Industrial PC (including changing the setting of the Operating Mode at Startup)
  - b) Changing the user program or settings
  - c) Changing set values or present values
  - d) Forced refreshing
- Always sufficiently check the safety at the connected devices before you change the settings of a slave or Unit.

## General Communications

---

- Do not exceed the ranges that are given in the specifications for the communications distance and number of connected Units.

## EtherCAT Communications

---

- Make sure that the communications distance, number of nodes connected, and method of connection for EtherCAT are within specifications.

Do not connect EtherCAT Coupler Units to EtherNet/IP, a standard in-house LAN, or other networks. An overload may cause the network to fail or malfunction.
- Malfunctions or unexpected operation may occur for some combinations of EtherCAT revisions of the master and slaves. If you disable the revision check in the network settings, check the slave revision settings in the master and the actual slave revisions, and then make sure that functionality is compatible in the manuals or other references. You can check the slave versions in the settings from the Sysmac Studio and you can check the actual slave revisions from the Sysmac Studio or on slave nameplates.
- After you transfer the user program, the CPU Unit is restarted and communications with the EtherCAT slaves are cut off. During that period, the slave outputs behave according to the *slave settings*. The time that communications are cut off depends on the EtherCAT network configuration. Before you transfer the user program, confirm that the system will not be adversely affected.

- EtherCAT communications are not always established immediately after the power supply is turned ON. Use the system-defined variables in the user program to confirm that communications are established before attempting control operations.
- If frames sent to EtherCAT slaves are lost due to noise or other causes, slave I/O data is not communicated, and the intended operation is sometimes not achieved. Perform the following processing if noise countermeasures are necessary.  
Program the Input Data Invalid system-defined variable as an interlock condition in the user program.  
Set the *PDO communications consecutive timeout detection count* setting in the EtherCAT master to at least 2.  
For details, refer to the user's manual for the built-in EtherCAT port on the connected CPU Unit or Industrial PC.
- When an EtherCAT slave is *disconnected*, communications will stop and control of the outputs will be lost not only for the disconnected slave, but for all slaves connected after it. Confirm that the system will not be adversely affected before you *disconnect* a slave.
- If you disconnect the cable from an EtherCAT slave or turn OFF the power supply of an EtherCAT slave to disconnect it from the network, any current communications frames may be lost. If frames are lost, slave I/O data is not communicated, and the intended operation is sometimes not achieved. Perform the following processing for a slave that needs to be replaced.  
Program the Input Data Invalid system-defined variable as an interlock condition in the user program.  
Set the *PDO communications consecutive timeout detection count* setting in the EtherCAT master to at least 2.  
For details, refer to the user's manual for the built-in EtherCAT port on the connected CPU Unit or Industrial PC.
- When you use an NJ/NX-series CPU Unit with the cable redundancy function in DC Mode, set the Communications Error Setting set value for EtherCAT slaves in DC Mode to the following value. If the communications cable is disconnected or the power supply of the EtherCAT slaves is turned OFF with the Communications Error Setting set value set to any other value, communications may discontinue due to a Communications Synchronization Error.  
Project unit version 1.42 or later: 2 or higher  
Project unit version earlier than 1.42: 1 (default value) or higher

## Unit Replacement

---

- When you replace a Unit, start operation only after you transfer the settings and variables that are required for operation to the new Unit.

## Disposal

---

- Dispose of the product according to local ordinances as they apply.

# Precautions for Correct Use

---

## Storage, Mounting, and Wiring

---

- Follow the instructions in this manual to correctly perform installation and wiring.
- Do not operate or store the Units in the following locations. Doing so may result in malfunction, in operation stopping, or in burning.
  - Locations subject to direct sunlight
  - Locations subject to temperatures or humidity outside the range specified in the specifications
  - Locations subject to condensation as the result of severe changes in temperature
  - Locations subject to corrosive or flammable gases
  - Locations subject to dust (especially iron dust) or salts
  - Locations subject to exposure to water, oil, or chemicals
  - Locations subject to shock or vibration
- Take appropriate and sufficient countermeasures during installation in the following locations.
  - Locations subject to strong, high-frequency noise
  - Locations subject to static electricity or other forms of noise
  - Locations subject to strong electromagnetic fields
  - Locations subject to possible exposure to radioactivity
  - Locations close to power lines
- Before touching a Unit, be sure to first touch a grounded metallic object in order to discharge any static build-up.
- Use the rated power supply voltage for the Units that supply power. Take appropriate measures to ensure that the specified power with the rated voltage and frequency is supplied in places where the power supply is unstable.
- Install the Units away from sources of heat and ensure proper ventilation. Not doing so may result in malfunction, in operation stopping, or in burning.
- Do not allow foreign matter to enter the openings in the Unit. Doing so may result in Unit burning, electric shock, or failure.
- Use the EtherCAT connection methods and cables that are specified in this manual, and the user's manual for the built-in EtherCAT port on the connected CPU Unit or Industrial PC. Otherwise, communications may be faulty.

## Actual Operation

---

- If you change the event level of an error, the output status when the error occurs may also change. Confirm safety before you change an event level.

## Turning OFF the Power Supply

---

- Do not turn OFF the power supply while data is being transferred.
- Do not turn OFF the power supply while parameters are being written to the Communications Coupler Unit or NX Units.

## EtherCAT Communications

---

- Do not disconnect the EtherCAT communications cables during operation. However, for the built-in EtherCAT port on an NJ/NX-series CPU Unit or NY-series Industrial PC, you can *disconnect* the communications cable from an EtherCAT Slave Terminal that has been disconnected from communications in the software.

# Regulations and Standards

## Conformance to EU Directives

### Applicable Directives

- EMC Directives
- Low Voltage Directive

### Concepts

#### ● EMC Directives

OMRON devices that comply with EC Directives also conform to the related EMC standards so that they can be more easily built into other devices or the overall machine. The actual products have been checked for conformity to EMC standards.\*1

Whether the products conform to the standards in the system used by the customer, however, must be checked by the customer. EMC-related performance of the OMRON devices that comply with EU Directives will vary depending on the configuration, wiring, and other conditions of the equipment or control panel on which the OMRON devices are installed. The customer must, therefore, perform the final check to confirm that devices and the overall machine conform to EMC standards.

\*1. Applicable EMC (Electromagnetic Compatibility) standards are as follows: EMS (Electromagnetic Susceptibility): EN 61131-2 EMI (Electromagnetic Interference): EN 61131-2 (Radiated emission: 10-m regulations).

#### ● Low Voltage Directive

Always ensure that devices operating at voltages of 50 to 1,000 VAC and 75 to 1,500 VDC meet the required safety standards. The applicable directive is EN61010-2-201.

#### ● Conformance to EU Directives

The NX-series Units comply with EU Directives. To ensure that the machine or device in which the NX-series Units are used complies with EU Directives, the following precautions must be observed.

- The NX-series Units must be installed within a control panel.
- You must use SELV power supply for the DC power supplies that are connected as the Unit power supplies and I/O power supplies for the NX-series Units.

We recommend that you use the OMRON S8JX-series Power Supplies. EMC standard compliance was confirmed for the recommended Power Supplies.

- NX-series Units that comply with EU Directives also conform to the Common Emission Standard (EN 61131-2). Radiated emission characteristics (10-m regulations) may vary depending on the configuration of the control panel used, other devices connected to the control panel, wiring, and other conditions.

You must therefore confirm that the overall machine or equipment in which the NX-series Units are used complies with EU Directives.

- You must use power supplies with an output hold time of 10 ms or longer for the DC power supplies that are connected as the Unit power supplies and I/O power supplies for the NX-series Units.

- This is a Class A product (for industrial environments). In a residential environment, it may cause radio interference. If radio interference occurs, the user may be required to take appropriate measures.

## Conformance to UL and CSA Standards

Some NX-series products comply with UL and CSA standards.

If you use an NX-series product that complies with UL or CSA standards and the machinery or system in which you use the NX-series product must also comply with the standards, refer to the *Instruction Sheet* that is provided with the product. The *Instruction Sheet* provides the application conditions for complying with the standards.

## Conformance to Shipbuilding Standards

Some NX-series products comply with shipbuilding standards. If you use an NX-series product that complies with shipbuilding standards and the machinery or system in which you use the NX-series product must also comply with the standards, consult with your OMRON representative. Application conditions are defined according to the installation location. Application may not be possible for some installation locations.

## Usage Conditions for NK and LR Shipbuilding Standards

- An EtherCAT Coupler Unit must be installed within a control panel.
- Gaps in the door to the control panel must be completely filled or covered with gaskets or other material.
- The following noise filter must be connected to the power supply line.

Name	Manufacturer	Model
Noise filter	Cosel Co., Ltd.	TAH-06-683

## Conformance to KC Certification

Observe the following precaution if you use NX-series Units in Korea.

A급 기기 (업무용 방송통신기자재)  
이 기기는 업무용(A급) 전자파적합기기로서 판매자 또는 사용자는 이 점을 주의하시기 바라며, 가정외의 지역에서 사용하는 것을 목적으로 합니다.

Class A Device (Broadcasting Communications Device for Office Use)

This device obtained EMC registration for office use (Class A), and it is intended to be used in places other than homes.

Sellers and/or users need to take note of this.

## Software Licenses and Copyrights

This product incorporates certain third party software. The license and copyright information associated with this software is available at [http://www.fa.omron.co.jp/nj\\_info\\_e/](http://www.fa.omron.co.jp/nj_info_e/).

# Unit Versions

This section describes the notation that is used for unit versions, the confirmation method for unit versions, and the relationship between unit versions and Support Software versions.

## Unit Versions

A “unit version” has been introduced to manage the Units in the NX Series according to differences in functionality accompanying Unit upgrades.

### Notation of Unit Versions on Products

The unit version is given with the Unit specifications on the side of the Unit or in the notched area.

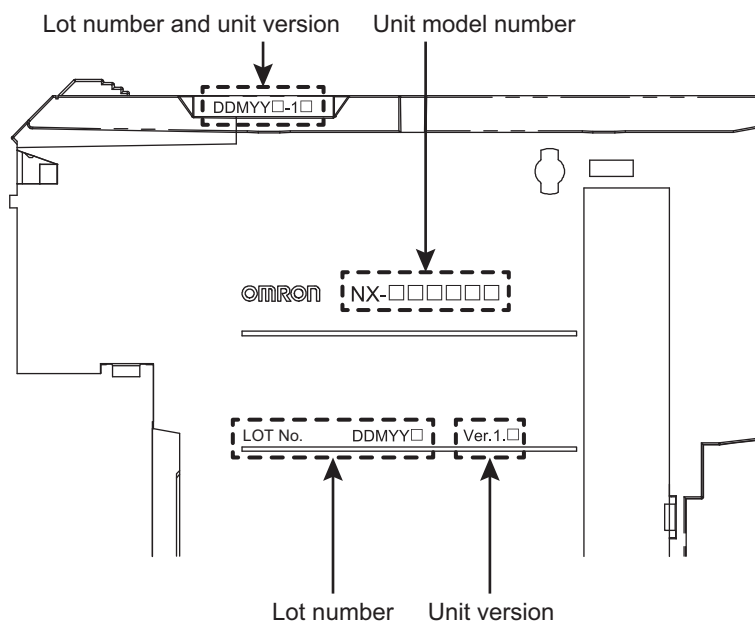
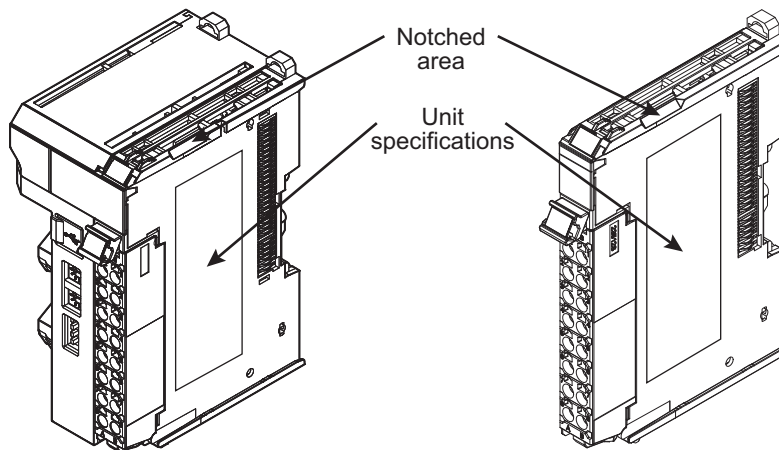

The following information is provided in the Unit specifications on the Unit.

Name	Function
Unit model number	Gives the model of the Unit.
Unit version	Gives the unit version of the Unit.
Lot number	Gives the lot number of the Unit. DDMYY□: Lot number, □: Used by OMRON. “M” gives the month (1 to 9: January to September, X: October, Y: November, Z: December)

The following information is provided in the notched area on the Unit.

Name	Function
Lot number and unit version	Gives the lot number and unit version of the Unit. <ul style="list-style-type: none"> <li>DDMYY□: Lot number, □: Used by OMRON. “M” gives the month (1 to 9: January to September, X: October, Y: November, Z: December)</li> <li>1□: Unit version The decimal portion of the unit version is omitted. (It is provided in the Unit specifications.)</li> </ul>

## Confirming Unit Versions with the Sysmac Studio

You can use the **Production Information** on the Sysmac Studio to check the unit versions of EtherCAT Coupler Unit Unit and NX Units.

- 1 Select **Configurations and Setup** in the Multiview Explorer and then select **EtherCAT**. Double-click the EtherCAT Coupler Unit under EtherCAT. Or, right-click the EtherCAT Coupler Unit and select **Edit** from the menu.

The Edit Slave Terminal Configuration Tab Page is displayed.

You can also display the Edit Slave Terminal Configuration Tab Page with any of the following operations.

Double-click **EtherCAT** under **Configurations and Setup** in the Multiview Explorer, right-click the EtherCAT Coupler Unit in the EtherCAT Configuration Edit Tab Page, and select **Edit Slave Terminal Configuration**.

Or, select the EtherCAT Coupler Unit on the EtherCAT Configuration Edit Tab Page, and then click the **Edit Slave Terminal Configuration** Button.

- 2 Go online.
- 3 Right-click the EtherCAT Coupler Unit and select **Display Production Information** from the menu.

The **Production Information** Dialog Box is displayed.

Model Information		Serial No.
Slot:000 NX-ECC201	Ver.1.0	00000001
Slot:001 NX-ID3417	Ver.1.0	00000000
Slot:002 NX-ID3417	Ver.1.0	00000000
Slot:003 NX-OD3153	Ver.1.0	00000000
Slot:004 NX-OD3153	Ver.1.0	00000000

Simple Display

Model Information		Serial No.
Slot:000 NX-ECC201	Ver.1.2	00000001
LOT No.00000		
Hardware Version	V1.00	
Software Version	V1.01.22 dev	
Total power-ON time	4 hours	
Slot:001 NX-OD3256	Ver.1.0	00000000
LOT No.38053		
Hardware Version	V1.00	
Total power-ON time	4 hours	
Slot:002 NX-OD3256	Ver.1.0	00000000
LOT No.38053		
Hardware Version	V1.00	
Total power-ON time	4 hours	
Slot:003 NX-ID3443	Ver.1.0	00000000
LOT No.38053		
Hardware Version	V1.00	
Total power-ON time	4 hours	

Detailed Display

The unit version is displayed on the right of the Unit model. The unit version is 1.0 in the example above.

The following items are displayed except the unit version.

- Slot number
- Unit model number
- Serial number
- Lot number
- Hardware version
- Software version
- Total power-ON time

The software version is displayed only for Units that contain software.



### Version Information

The total power-ON time is provided by function to monitor the total power-ON time. The function to monitor the total power-ON time was added for a version upgrade. Refer to *A-11-2 Functions That Were Added or Changed for Each Unit Version* on page A-103 for the versions that support monitoring the total power-ON time.

## Unit Versions and Sysmac Studio Versions

The functions that are supported depend on the unit version of the Unit. The version of Sysmac Studio that supports the functions that were added for an upgrade is also required to use those functions. Refer to *A-11 Version Information* on page A-102 for the functions that are supported by each unit version.

# Related Manuals

The following manuals are related. Use these manuals for reference.

Manual name	Cat. No.	Model numbers	Application	Description
NX-series EtherCAT® Coupler Unit User's Manual	W519	NX-ECC20□	Learning how to use an NX-series EtherCAT Coupler Unit and EtherCAT Slave Terminals.	The following items are described: the overall system and configuration methods of an EtherCAT Slave Terminal (which consists of an NX-series EtherCAT Coupler Unit and NX Units), and information on hardware, setup, and functions to set up, control, and monitor NX Units through EtherCAT.
Sysmac Studio Version 1 Operation Manual	W504	SYSMAC -SE2□□□	Learning about the operating procedures and functions of the Sysmac Studio.	Describes the operating procedures of the Sysmac Studio.
NJ/NX-series Troubleshooting Manual	W503	NX701-□□□□ NX502-□□□□ NX102-□□□□ NX1P2-□□□□ NJ501-□□□□ NJ301-□□□□ NJ101-□□□□	Learning about the errors that may be detected in an NJ/NX-series Controller.	Concepts on managing errors that may be detected in an NJ/NX-series Controller and information on individual errors are described.
NY-series Troubleshooting Manual	W564	NY532-□□□□ NY512-□□□□	Learning about the errors that may be detected in an NY-series Industrial PC.	Concepts on managing errors that may be detected in an NY-series Controller and information on individual errors are described.
NX-series Data Reference Manual	W525	NX-□□□□□□	Referencing lists of the data that is required to configure systems with NX-series Units.	Lists of the power consumptions, weights, and other NX Unit data that is required to configure systems with NX-series Units are provided.
NX-series Digital I/O Units User's Manual	W521	NX-ID□□□□ NX-IA□□□□ NX-OC□□□□ NX-OD□□□□ NX-MD□□□□	Learning how to use NX-series Digital I/O Units.	The hardware, setup methods, and functions of the NX-series Digital I/O Units are described.
NX-series Analog I/O Units User's Manual for Analog Input Units and Analog Output Units	W522	NX-AD□□□□ NX-DA□□□□	Learning how to use NX-series Analog Input Units and Analog Output Units.	The hardware, setup methods, and functions of the NX-series Analog Input Units and Analog Output Units are described.
NX-series System Units User's Manual	W523	NX-PD1□□□ NX-PF0□□□ NX-PC0□□□ NX-TBX01	Learning how to use NX-series System Units.	The hardware and functions of the NX-series System Units are described.

Manual name	Cat. No.	Model numbers	Application	Description
NX-series Position Interface Units User's Manual	W524	NX-EC0□□□ NX-ECS□□□ NX-PG0□□□	Learning how to use NX-series Position Interface Units.	The hardware, setup, and functions for the NX-series Incremental Encoder Input Units, SSI Input Units, and Pulse Output Unit are described.
NX-series Load Cell Input Unit User's Manual	W565	NX-RS□□□□	Learning how to use an NX-series Load Cell Input Unit.	The hardware, setup methods, and functions of the NX-series Load Cell Input Unit are described.
NX-series Analog I/O Units User's Manual for Temperature Input Units and Heater Burnout Detection Units	W566	NX-TS□□□□ NX-HB□□□□	Learning how to use NX-series Temperature Input Units and Heater Burnout Detection Units.	The hardware, setup methods, and functions of the NX-series Temperature Input Units and Heater Burnout Detection Units are described.
NX-series IO-Link Master Unit User's Manual	W567	NX-ILM400	Learning hardware information, wiring, and specifications for the NX-series IO-Link Master Unit and checking a list of NX objects.	Describes part names, functions, installation, and wiring and also provides tables of specifications and NX objects for the NX-series IO-Link Master Unit.
NX-series Communications Interface Units User's Manual	W540	NX-CIF□□□□	Learning how to use NX-series Communications Interface Units	The hardware, setup methods, and functions of the NX-series Communications Interface Units are described.
NX-series Temperature Control Units User's Manual	H228	NX-TC□□□□	Learning how to use NX-series Temperature Control Units.	The hardware, setup methods, and functions of the NX-series Temperature Control Units are described.
NX-series Safety Control Unit User's Manual	Z930	NX-SL□□□□ NX-SI□□□□ NX-SO□□□□	Learning how to use NX-series Safety Control Units.	Describes the hardware, setup methods, and functions of the NX-series Safety Control Units.
NX-series Safety Control Unit Instructions Reference Manual	Z931	NX-SL□□□□	Learning about the specifications of instructions for the Safety CPU Unit.	Describes the instructions for the Safety CPU Unit.
NX-series CPU Unit Hardware User's Manual	W535	NX701-□□□□	Learning the basic specifications of the NX701 CPU Units, including introductory information, designing, installation, and maintenance. Mainly hardware information is provided.	An introduction to the entire NX701 system is provided along with the following information on the CPU Unit. <ul style="list-style-type: none"> <li>• Features and system configuration</li> <li>• Introduction</li> <li>• Part names and functions</li> <li>• General specifications</li> <li>• Installation and wiring</li> <li>• Maintenance and inspection</li> </ul>

Manual name	Cat. No.	Model numbers	Application	Description
NX-series NX502 CPU Unit Hardware User's Manual	W629	NX502-□□□□	Learning the basic specifications of the NX502 CPU Units, including introductory information, designing, installation, and maintenance. Mainly hardware information is provided.	An introduction to the entire NX502 system is provided along with the following information on the CPU Unit. <ul style="list-style-type: none"> <li>• Features and system configuration</li> <li>• Introduction</li> <li>• Part names and functions</li> <li>• General specifications</li> <li>• Installation and wiring</li> <li>• Maintenance and inspection</li> </ul>
NX-series NX102 CPU Unit Hardware User's Manual	W593	NX102-□□□□	Learning the basic specifications of the NX102 CPU Units, including introductory information, designing, installation, and maintenance. Mainly hardware information is provided.	An introduction to the entire NX102 system is provided along with the following information on the CPU Unit. <ul style="list-style-type: none"> <li>• Features and system configuration</li> <li>• Introduction</li> <li>• Part names and functions</li> <li>• General specifications</li> <li>• Installation and wiring</li> <li>• Maintenance and inspection</li> </ul>
NX-series NX1P2 CPU Unit Hardware User's Manual	W578	NX1P2-□□□□	Learning the basic specifications of the NX1P2 CPU Units, including introductory information, designing, installation, and maintenance. Mainly hardware information is provided.	An introduction to the entire NX1P2 system is provided along with the following information on the CPU Unit. <ul style="list-style-type: none"> <li>• Features and system configuration</li> <li>• Introduction</li> <li>• Part names and functions</li> <li>• General specifications</li> <li>• Installation and wiring</li> <li>• Maintenance and inspection</li> </ul>
NJ-series CPU Unit Hardware User's Manual	W500	NJ501-□□□□ NJ301-□□□□ NJ101-□□□□	Learning the basic specifications of the NJ-series CPU Units, including introductory information, designing, installation, and maintenance. Mainly hardware information is provided.	An introduction to the entire NJ-series system is provided along with the following information on the CPU Unit. <ul style="list-style-type: none"> <li>• Features and system configuration</li> <li>• Introduction</li> <li>• Part names and functions</li> <li>• General specifications</li> <li>• Installation and wiring</li> <li>• Maintenance and inspection</li> </ul>
NJ/NX-series CPU Unit Software User's Manual	W501	NX701-□□□□ NX502-□□□□ NX102-□□□□ NX1P2-□□□□ NJ501-□□□□ NJ301-□□□□ NJ101-□□□□	Learning how to program and set up an NJ/NX-series CPU Unit. Mainly software information is provided.	The following information is provided on a Controller built with an NJ/NX-series CPU Unit. <ul style="list-style-type: none"> <li>• CPU Unit operation</li> <li>• CPU Unit features</li> <li>• Initial settings</li> <li>• Programming based on IEC 61131-3 language specifications</li> </ul>

Manual name	Cat. No.	Model numbers	Application	Description
NJ/NX-series CPU Unit Built-in EtherCAT® Port User's Manual	W505	NX701-□□□□ NX502-□□□□ NX102-□□□□ NX1P2-□□□□ NJ501-□□□□ NJ301-□□□□ NJ101-□□□□	Using the built-in EtherCAT port on an NJ/NX-series CPU Unit.	Information on the built-in EtherCAT port is provided. This manual provides an introduction and provides information on the configuration, features, and setup.
NJ/NX-series Instructions Reference Manual	W502	NX701-□□□□ NX502-□□□□ NX102-□□□□ NX1P2-□□□□ NJ501-□□□□ NJ301-□□□□ NJ101-□□□□	Learning detailed specifications on the basic instructions of an NJ/NX-series CPU Unit.	The instructions in the instruction set (IEC 61131-3 specifications) are described.
NJ/NX-series CPU Unit Motion Control User's Manual	W507	NX701-□□□□ NX502-□□□□ NX102-□□□□ NX1P2-□□□□ NJ501-□□□□ NJ301-□□□□ NJ101-□□□□	Learning about motion control settings and programming concepts.	The settings and operation of the CPU Unit and programming concepts for motion control are described.
NY-series IPC Machine Controller Industrial Panel PC Hardware User's Manual	W557	NY532-□□□□	Learning the basic specifications of the NY-series Industrial Panel PCs, including introductory information, designing, installation, and maintenance. Mainly hardware information is provided.	An introduction to the entire NY-series system is provided along with the following information on the Industrial Panel PC. <ul style="list-style-type: none"> <li>• Features and system configuration</li> <li>• Introduction</li> <li>• Part names and functions</li> <li>• General specifications</li> <li>• Installation and wiring</li> <li>• Maintenance and inspection</li> </ul>
NY-series IPC Machine Controller Industrial Box PC Hardware User's Manual	W556	NY512-□□□□	Learning the basic specifications of the NY-series Industrial Box PCs, including introductory information, designing, installation, and maintenance. Mainly hardware information is provided.	An introduction to the entire NY-series system is provided along with the following information on the Industrial Box PC. <ul style="list-style-type: none"> <li>• Features and system configuration</li> <li>• Introduction</li> <li>• Part names and functions</li> <li>• General specifications</li> <li>• Installation and wiring</li> <li>• Maintenance and inspection</li> </ul>
NY-series IPC Machine Controller Industrial Panel PC / Industrial Box PC Software User's Manual	W558	NY532-□□□□ NY512-□□□□	Learning how to program and set up the Controller functions of an NY-series Industrial PC.	The following information is provided on the NY-series Controller functions. <ul style="list-style-type: none"> <li>• Controller operation</li> <li>• Controller features</li> <li>• Controller settings</li> <li>• Programming based on IEC 61131-3 language specifications</li> </ul>

Manual name	Cat. No.	Model numbers	Application	Description
NY-series IPC Machine Controller Industrial Panel PC / Industrial Box PC Built-in EtherCAT® Port User's Manual	W562	NY532-□□□□ NY512-□□□□	Using the built-in EtherCAT port in an NY-series In- dustrial PC.	Information on the built-in EtherCAT port is provided. This manual provides an introduc- tion and provides information on the configuration, features, and setup.
NY-series Instructions Reference Manual	W560	NY532-□□□□ NY512-□□□□	Learning detailed specifications on the basic instruc- tions of an NY- series Industrial PC.	The instructions in the instruction set (IEC 61131-3 specifications) are described.
NY-series IPC Machine Controller Industrial Panel PC / In- dustrial Box PC Motion Control User's Manual	W559	NY532-□□□□ NY512-□□□□	Learning about motion control settings and pro- gramming con- cepts of an NY- series Industrial PC.	The settings and operation of the Controller and programming con- cepts for motion control are descri- bed.

# Terminology

Term	Abbreviation	Description
application layer status, AL status	---	Status for indicating information on errors that occur in an application on a slave.
CAN application protocol over EtherCAT	CoE	A CAN application protocol service implemented on EtherCAT.
CAN in Automation	CiA	CiA is the international users' and manufacturers' group that develops and supports higher-layer protocols.
DC time	---	EtherCAT slaves that support distributed clock synchronization have a clock that is shared by all slaves in the network. The time that is based on this distributed clock is called the DC time.
EtherCAT slave controller	ESC	A controller for EtherCAT slave communications.
EtherCAT slave information	ESI	An XML file that contains setting information for an EtherCAT slave.
EtherCAT state machine	ESM	An EtherCAT communications state machine.
EtherCAT Technology Group	ETG	The ETG is a global organization in which OEM, end users, and technology providers join forces to support and promote the further technology development.
I/O port	---	A logical interface that is used by the NJ/NX-series CPU Unit or NY-series Industrial PC to exchange data with an external device (slave or Unit).
I/O map settings	---	Settings that assign variables to I/O ports. Assignment information between I/O ports and variables.
I/O refreshing	---	Cyclic data exchange with external devices that is performed with predetermined memory addresses.
NX bus	---	The NX-series internal bus.
PDO communications	---	An acronym for process data communications.
SDO communications	---	One type of EtherCAT communications in which service data objects (SDOs) are used to transmit information whenever required. Refer to the user's manual for the built-in EtherCAT port on the connected CPU Unit or Industrial PC for details.
Slave Information Interface	SII	Slave information that is stored in non-volatile memory in the slave.
Sync0	---	A signal that gives the interrupt timing based on the distributed clock (DC) in EtherCAT communications. The slaves execute controls according to this interrupt timing.
index	---	Address of an object within an application process.
object	---	An abstract representation of a particular component within a device, which consists of data, parameters, and methods.
object dictionary	OD	Data structure that contains description of data type objects, communication objects and application objects.
Operational	---	A state in which I/O refresh communications and NX message communications are possible between the communications master and the Communications Coupler Unit or NX Units.
Operational	---	A state in EtherCAT communications where SDO communications and I/O are possible.

Term	Abbreviation	Description
Virtual SD Memory Card	---	<p>A shared folder for the Machine Automation Control Software to handle files.</p> <p>An SD Memory Card is used in the NJ/NX-series CPU Unit which is treated as the Controller for Sysmac. In the NY-series Controller, however, a shared folder with Windows is handled as a Virtual SD Memory Card.</p> <p>To use the same name for the same functionality supported by NJ-series, NX-series, and NY-series Controllers, <i>virtual</i> is sometimes omitted and only <i>SD Memory Card</i> is used.</p>
cable redundancy	---	A function for continuing the communications even when cable disconnection or slave power failure occurs on the EtherCAT system.
service data object	SDO	CoE asynchronous mailbox communications where all objects in the object dictionary can be read and written.
subindex	---	Sub-address of an object within the object dictionary.
receive PDO	RxPDO	A process data object received by an EtherCAT slave.
Sync Manager	SM	Collection of control elements to coordinate access to concurrently used objects.
Slave Terminal	---	A building-block remote I/O terminal, which consists of a Communication Coupler Unit connected with NX Units.
Safe-Operational	---	A state in EtherCAT communications where only SDO communications and reading input data from slaves are possible. Outputs from slaves are not performed.
project unit version	---	A unit version to be set for the project. It is set for the project in the Select Device Area of the Project Properties Dialog Box on the Sysmac Studio.
transmit PDO	TxPDO	A process data object sent from an EtherCAT slave.
task period	---	<p>The interval at which the primary periodic task or a periodic task is executed.</p> <p>Refer to the software user's manual for the connected CPU Unit or Industrial PC for details.</p>
Communications Coupler Units	---	The generic name of an interface unit for remote I/O communications on a network between NX Units and a host network master.
distributed clock	DC	Clock distribution mechanism used to synchronize EtherCAT slaves and the EtherCAT master.
device profile	---	A collection of device dependent information and functionality providing consistency between similar devices of the same device type.
device variable	---	<p>A variable that is used to access a specific device through an I/O port by an NJ/NX-series CPU Unit or NY-series Industrial PC.</p> <p>Process data on an EtherCAT slave is allocated to this variable. For NX-series CPU Units to which NX Units can be connected, I/O data for the NX Units on a CPU Unit is allocated. A user application on a CPU Unit or Industrial PC accesses a device that can be connected, by directly reading and writing this device variable.</p>
device variable	---	<p>A variable in the NJ/NX-series CPU Unit or NY-series Industrial PC to which process data on an EtherCAT slave is allocated.</p> <p>Slave process data is accessed by directly reading and writing device variables from user applications on an NJ/NX-series CPU Unit or an NY-series Industrial PC.</p>
network configuration information	---	The EtherCAT network configuration information held by the EtherCAT master.

Term	Abbreviation	Description
primary periodic task	---	The task with the highest priority. Refer to the software user's manual for the connected CPU Unit or Industrial PC for details.
Pre-Operational	---	A state in EtherCAT communications where only SDO communications are possible with the slaves, i.e., no I/O can be performed.
process data	---	Collection of application objects designated to be transferred cyclically or acyclically for the purpose of measurement and control.
process data object	PDO	A structure that describes the mappings of parameters that have one or more process data entities.
process data communications	---	One type of EtherCAT communications in which process data objects (PDOs) are used to exchange information cyclically and in realtime. This is also called PDO communications.

# Revision History

A manual revision code appears as a suffix to the catalog number on the front and back covers of the manual.

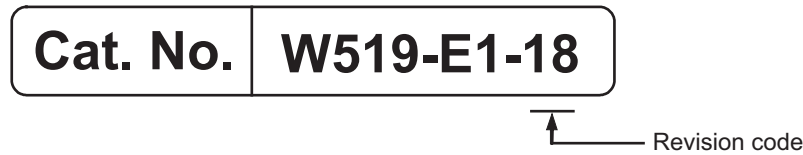

Revision code	Date	Revised content
01	April 2013	Original production
02	June 2013	<ul style="list-style-type: none"> <li>• Made changes accompanying the upgrade to unit version 1.1.</li> <li>• Corrected mistakes.</li> </ul>
03	September 2013	<ul style="list-style-type: none"> <li>• Made changes accompanying the upgrade to unit version 1.2.</li> <li>• Added NX-ECC202.</li> <li>• Corrected mistakes.</li> </ul>
04	March 2014	<ul style="list-style-type: none"> <li>• Made revisions accompanying the upgrade to Sysmac Studio version 1.09.</li> <li>• Corrected mistakes.</li> </ul>
05	April 2015	<ul style="list-style-type: none"> <li>• Added NX-ECC203.</li> <li>• Made revisions accompanying the addition of NX-series CPU Units.</li> <li>• Corrected mistakes.</li> </ul>
06	April 2016	<ul style="list-style-type: none"> <li>• Made revisions accompanying the addition of NX Unit models.</li> <li>• Corrected mistakes.</li> </ul>
07	July 2016	<ul style="list-style-type: none"> <li>• Made revisions accompanying the addition of the NX Unit models.</li> <li>• Made changes accompanying the upgrade of the NX-ECC203 unit version to version 1.4.</li> <li>• Corrected mistakes.</li> </ul>
08	October 2016	<ul style="list-style-type: none"> <li>• Made revisions accompanying addition of NX Unit models.</li> <li>• Made revisions accompanying the addition of NY-series IPC Machine Controller Industrial Panel PCs and Industrial Box PCs.</li> <li>• Made changes accompanying the addition of the NX-series NX1P2 CPU Unit.</li> <li>• Corrected mistakes.</li> </ul>
09	June 2017	<ul style="list-style-type: none"> <li>• Made changes accompanying the upgrade of the NX-ECC203 unit version to version 1.5.</li> <li>• Corrected mistakes.</li> </ul>
10	April 2018	<ul style="list-style-type: none"> <li>• Made revisions accompanying the addition of NX-series NX102 CPU Units.</li> <li>• Corrected mistakes.</li> </ul>
11	October 2018	<ul style="list-style-type: none"> <li>• Made changes accompanying the upgrade of the NX-ECC203 unit version to version 1.6.</li> <li>• Made revisions accompanying the appearance change of the indicators.</li> <li>• Corrected mistakes.</li> </ul>
12	December 2018	<ul style="list-style-type: none"> <li>• Made revisions accompanying the change in label of the rotary switches and DIP switch for the NX-ECC201 and NX-ECC202.</li> <li>• Corrected mistakes.</li> </ul>
13	July 2019	<ul style="list-style-type: none"> <li>• Made changes accompanying the upgrade of the NJ/NX-series CPU Units to unit version 1.40.</li> <li>• Corrected mistakes.</li> </ul>

Revision code	Date	Revised content
14	July 2020	<ul style="list-style-type: none"><li>• Made changes accompanying the upgrade of the NX-ECC203 unit version to version 1.7.</li><li>• Corrected mistakes.</li></ul>
15	August 2020	<ul style="list-style-type: none"><li>• Made changes accompanying the upgrade of the NJ/NX-series CPU Units to unit version 1.42.</li><li>• Corrected mistakes.</li></ul>
16	July 2022	Revisions for adding safety precautions regarding security.
17	April 2025	Corrected mistakes.
18	October 2025	Corrected mistakes.





# 1

# EtherCAT Networks

---

This section provides an introduction to EtherCAT networks.

---

<b>1-1</b>	<b>Introduction to EtherCAT</b> .....	<b>1-2</b>
1-1-1	How EtherCAT Works.....	1-2
1-1-2	Types of EtherCAT Communications .....	1-4
<b>1-2</b>	<b>EtherCAT Network Configuration Elements</b> .....	<b>1-5</b>
1-2-1	System Configuration Example of an EtherCAT Network .....	1-5
1-2-2	Introduction to Configuration Devices .....	1-6

# 1-1 Introduction to EtherCAT

EtherCAT (Ethernet Control Automation Technology) is a high-performance industrial network system that enables faster and more efficient communications based on Ethernet.

Each node achieves a short communications cycle time by transmitting Ethernet frames at high speed. Although EtherCAT is a unique communications protocol, standard Ethernet technology is used for the physical layer, which means you can use Ethernet cables for wider application.

And the effectiveness of EtherCAT can be fully utilized not only in large control systems that require high processing speeds and system integrity, but also in small and medium control systems.

## 1-1-1 How EtherCAT Works

With EtherCAT, Ethernet frames pass through all of the slave nodes.

When a frame passes through a slave node, the slave node reads and writes the data in the area that is allocated to it in the frame in a few nanoseconds.

The Ethernet frames that are transmitted by the EtherCAT master pass through all EtherCAT slaves without stopping. The last slave returns all of the frames, which again pass through all of the slaves before returning to the EtherCAT master.

This mechanism ensures high speed and realtime data transmission.

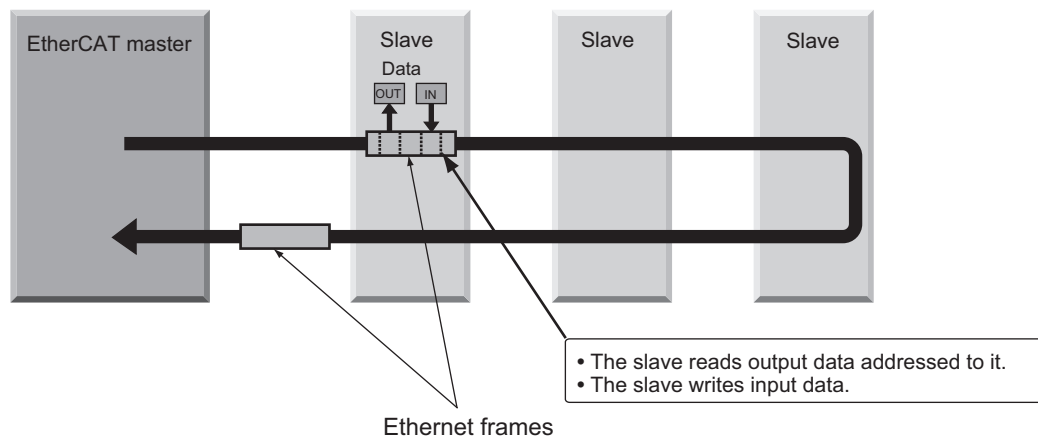

The data exchanges that are cyclically performed between the EtherCAT master and EtherCAT slaves use *EtherCAT datagrams* that are stored directly in the Ethernet frames.

Each *EtherCAT datagram* consists of a header (including the data length and one or more slave addresses), data, and a working counter (i.e., check bits).

If you think of an Ethernet frame as a *train*, the EtherCAT datagrams would be the *cars* of the train.

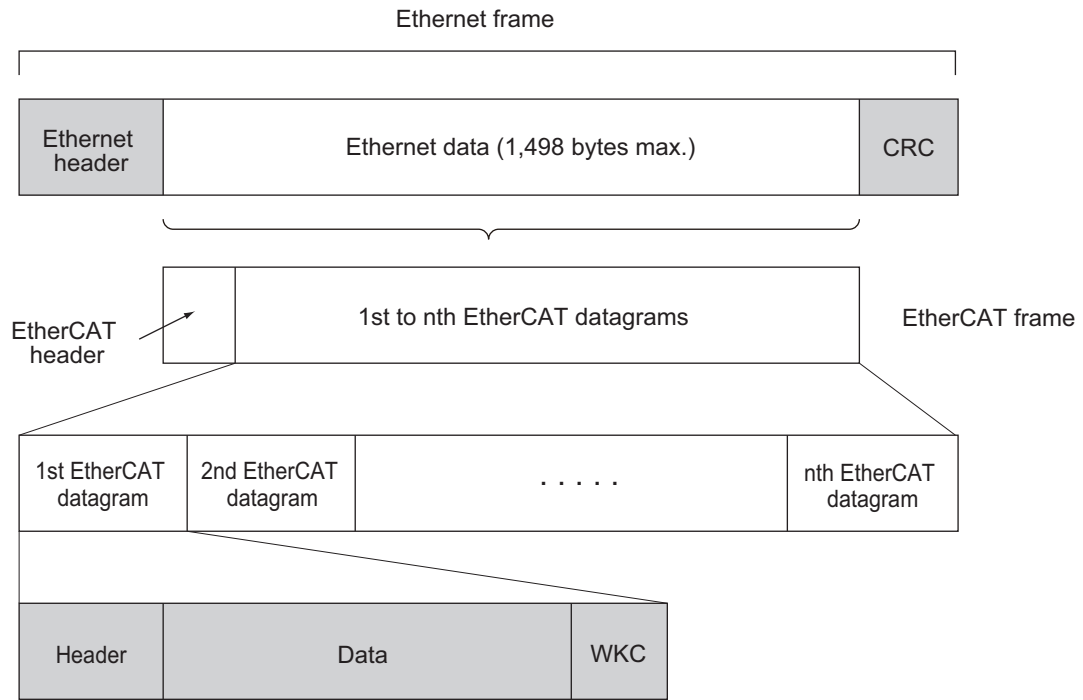

WKC: Working counter

## 1-1-2 Types of EtherCAT Communications

The following 2 types of communications are available with EtherCAT.

PDO communications are executed in each EtherCAT communications cycle to refresh data continuously. SDO communications are executed between PDO communications.

### Process Data Communications (PDO Communications)

PDO communications transfers process data cyclically and in realtime.

The EtherCAT master maps the logical process data space to the nodes to achieve cyclic communications between the EtherCAT master and slaves.

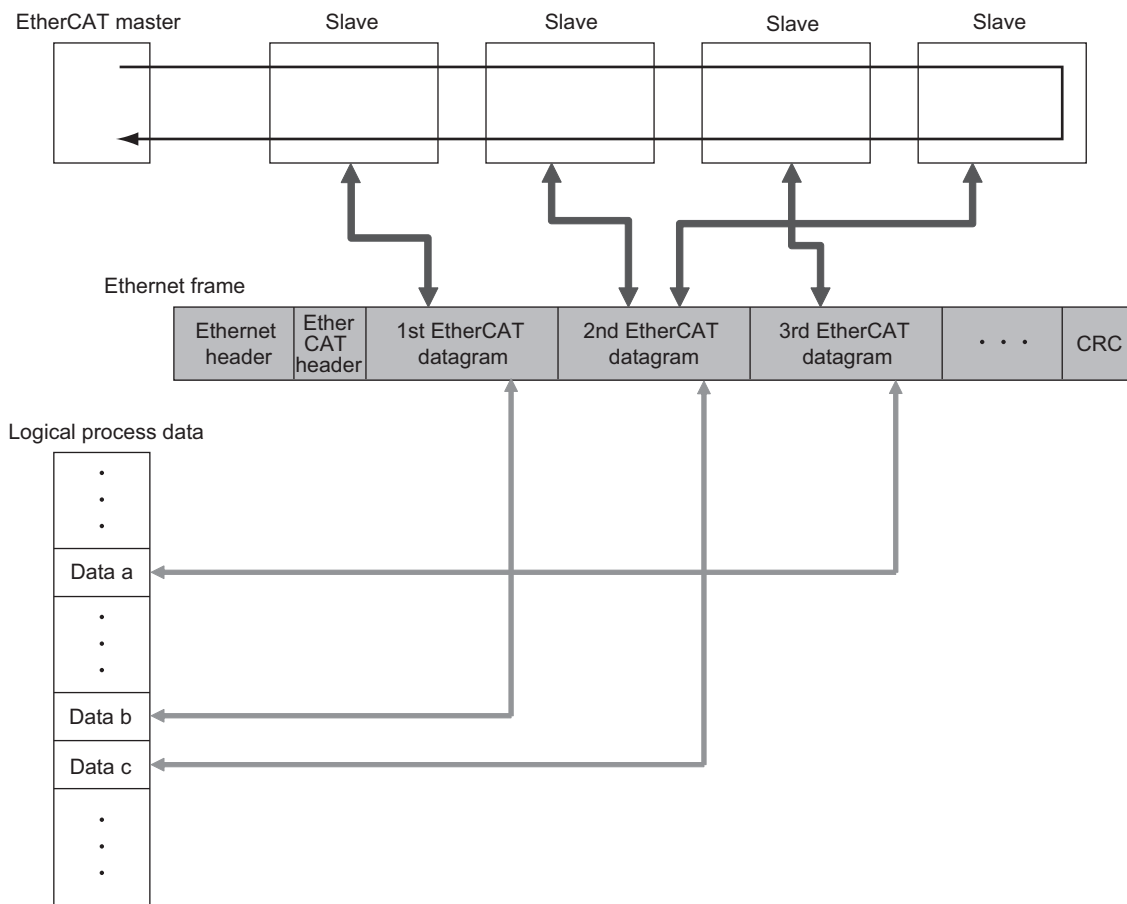

### Mailbox Communications (SDO Communications)

SDO communications is used to perform message communications.

Whenever necessary, the EtherCAT master sends a command to a slave, and then the slave returns a response to the EtherCAT master.

The following data communications can be performed.

- Reading and writing process data
- Setting slaves
- Monitoring slave status

# 1-2 EtherCAT Network Configuration Elements

This section describes the devices that configure EtherCAT networks and the usage of those devices.

## 1-2-1 System Configuration Example of an EtherCAT Network

This section provides a system configuration example of an EtherCAT network.

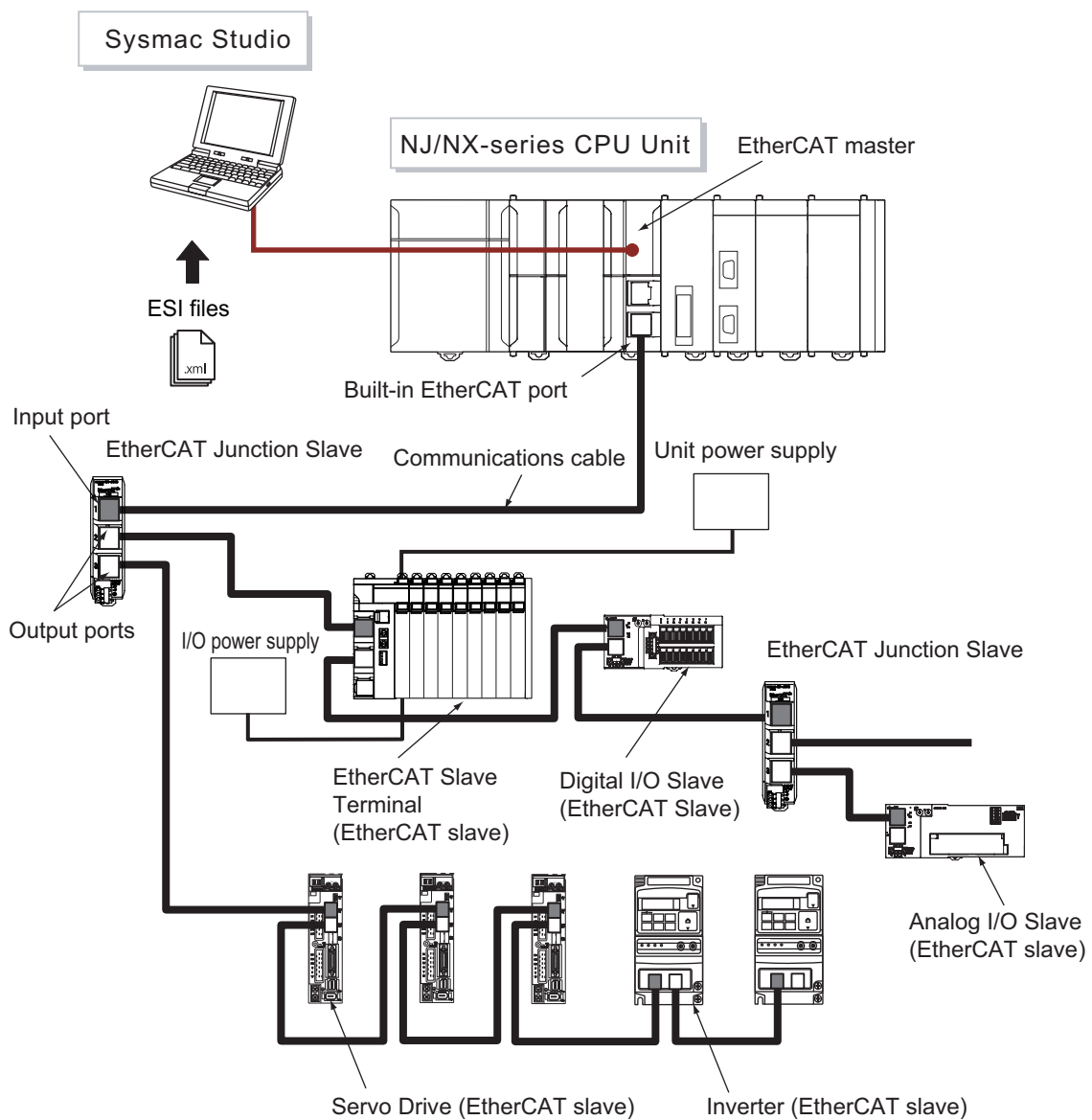

## 1-2-2 Introduction to Configuration Devices

This section introduces the configuration devices.

### EtherCAT Master

The EtherCAT master manages the network, monitors the status of the slaves, and exchanges I/O data with the slaves.

### EtherCAT Slaves

The EtherCAT slaves output the output data that is received from the EtherCAT master through the EtherCAT network. They also send input data to the EtherCAT master through the EtherCAT network.

### EtherCAT Slave Terminals

An EtherCAT Slave Terminal is a building-block slave that is created by mounting a group of NX Units to an EtherCAT Coupler Unit.

#### ● EtherCAT Coupler Units

An EtherCAT Coupler Unit is a Communications Coupler Unit that connects NX Units to an EtherCAT network.

#### ● NX Units

The NX Units perform process data communications with the EtherCAT master through the EtherCAT Coupler Unit.

Refer to *Section 2 Features and System Configuration* on page 2-1 for details on the features and system configuration of an EtherCAT Slave Terminal.

### EtherCAT Junction Slaves

A Junction Slave is used only to branch EtherCAT network wiring.

### Sysmac Studio

The Sysmac Studio runs on a personal computer and it is used to configure EtherCAT networks and slaves, and to perform programming, monitoring, and troubleshooting.

### Communications Cables

Use double-shielded cables with aluminum tape and braiding of Ethernet category 5 (100BASE-TX) or higher, and use straight wiring.

## ESI (EtherCAT Slave Information) Files

---

The ESI files contain information that is unique to the EtherCAT slaves in XML format.

You can load an ESI file into the Sysmac Studio to easily allocate slave process data and make other settings.

The ESI files for OMRON EtherCAT slaves are already installed in the Sysmac Studio. You can update the Sysmac Studio to get the ESI files for the most recent models.

## Unit Power Supplies

---

Unit power supplies provide power for communications and the internal operation of EtherCAT Slave Terminals.

## I/O Power Supplies

---

I/O power supplies provide power for the I/O operation of the external devices that are connected to EtherCAT Slave Terminals.



# 2

## Features and System Configuration

This section describes the features and system configurations of EtherCAT Slave Terminals.

---

<b>2-1</b>	<b>Features of EtherCAT Slave Terminals .....</b>	<b>2-2</b>
<b>2-2</b>	<b>System Configurations of EtherCAT Slave Terminals .....</b>	<b>2-6</b>
2-2-1	System Configuration .....	2-6
2-2-2	Types of NX Units.....	2-8
2-2-3	Safety Control System.....	2-9
<b>2-3</b>	<b>Support Software .....</b>	<b>2-10</b>
2-3-1	Applicable Support Software .....	2-10
2-3-2	Connection Method and Procedures.....	2-10
2-3-3	Scope of Access When Connected to the USB Port on the EtherCAT Coupler Unit .....	2-12

## 2-1 Features of EtherCAT Slave Terminals

---

An EtherCAT Slave Terminal is a building-block EtherCAT slave that is created by mounting a group of NX Units to an EtherCAT Coupler Unit.

The NX Units can be flexibly combined with an EtherCAT Coupler Unit to achieve the optimum EtherCAT slave for the application with less wiring, less work, and less space.

The features of the EtherCAT Slave Terminals are described below.

### Optimum Functionality and Ease of Operation Based on Unified Specifications

---

The EtherCAT Coupler Unit is designed with the same communications and user interface specifications as other Sysmac devices. This provides optimum functionality and ease of operation when used together with NJ/NX/NY-series Machine Automation Controllers, and the Sysmac Studio Automation Software.

### The Entire System Provides Extremely Accurate Synchronized Control

---

When the EtherCAT Coupler Unit is used together with NX Units that support synchronous I/O refreshing, all I/O refreshing is synchronized with the task periods of the primary periodic task and priority-5 periodic task of the NJ/NX-series CPU Unit or NY-series Industrial PC.\*<sup>1</sup> This provides an even higher level of synchronized control accuracy because it suppresses jitter in the I/O response of the overall system.

This allows you to achieve the following control performance.

- Multiple Digital Input Units that support synchronous input refreshing process their inputs simultaneously, which improves the control accuracy of the system.
- Multiple Digital Output Units that support synchronous output refreshing process their outputs simultaneously. This allows the outputs to refresh output devices in multiple locations at the same time.

\*1. The periodic tasks for which the CPU Unit or Industrial PC supports EtherCAT Slave Terminals depend on the model of the CPU Unit or Industrial PC. Refer to *Assignment and Settings Related to Tasks* in the software user's manual for the connected CPU Unit or Industrial PC for information on the periodic tasks that are supported by the CPU Unit or Industrial PC.

## Controlling Outputs at Specific Intervals after Inputs Change

When the EtherCAT Coupler Units are used together with NX Units that support input refreshing with input changed times and with other NX Units that support output refreshing with specified time stamps, you can control the outputs to be given at specific intervals after the sensor inputs change.

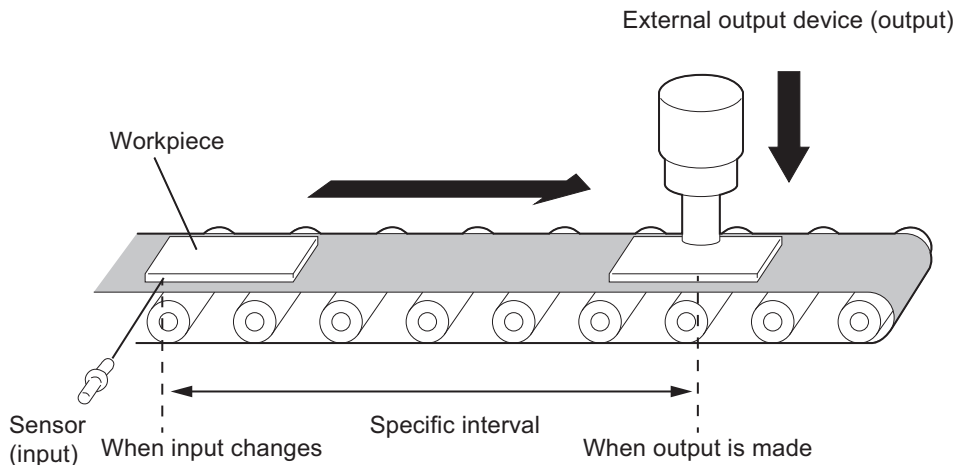

## Selecting a Refreshing Method to Give Priority to Shortening the Task Period

You can select the following refreshing method to give priority to shortening the task period.\*1

- Task Period Prioritized Refreshing

With synchronous I/O refreshing, the I/O timing of two or more NX Units are synchronized. If there is an NX Unit that is set for synchronous I/O refreshing in the configuration and it requires time for I/O processing, the refresh cycle of the NX bus is increased in comparison to a configuration that does not have such an NX Unit.

You can select task period prioritized refreshing to give priority to shortening the task period over synchronization of the I/O timing.

\*1. Of the EtherCAT Coupler Units, only the NX-ECC203 supports this refreshing method. The NX Units must also support task period prioritized refreshing. Refer to the manuals for the specific Units for the refreshing methods that are supported by individual NX Units.

## Features That Reduce Work in Designing and Commissioning Equipment

- **Registering NX Units in the Unit Configuration Information as Unmounted Units for Future Expansion (Designing and Commissioning)**

You can register any NX Units as unmounted Units in the Unit configuration information. This allows the following possibilities.

- NX Units for future expansion can be registered in advance. This eliminates the need to change the user program when the NX Units are actually added. (Designing)
- If certain NX Units are temporarily unavailable, you can still debug the system in advance with the NX Units that are available. (Commissioning)

- **Exporting/importing Slave Terminal Settings and NX Unit Settings (Designing)**

You can use the Sysmac Studio to export and import the EtherCAT Slave Terminal settings and NX Unit settings as files. This allows you to reuse settings from an EtherCAT Slave Terminal or NX Units for other EtherCAT Slave Terminals or NX Units.

- **Simplified I/O Wiring with Screwless Clamping Terminal Blocks (Commissioning)**

The EtherCAT Coupler Unit and the NX Units use screwless clamping terminal blocks. The use of ferrules makes wiring an easy matter of inserting them. The screwless design greatly reduces wiring work.

- **Support for Event Logs and Troubleshooting (Commissioning)**

The EtherCAT Coupler Units support the event logs in the NJ/NX-series CPU Units and NY-series Industrial PCs and troubleshooting on the Sysmac Studio. This gives the event codes which allow you to determine the cause of errors, and reduce the recovery work when an error occurs.

- **Back up, Restore, and Compare Data with SD Memory Cards and the Sysmac Studio (Commissioning)**

You can back up, restore, and compare EtherCAT Slave Terminal settings to data on an SD Memory Card inserted in the NJ/NX-series CPU Unit, or a specified folder on the computer.

You can use an NY-series Industrial PC to back up or compare EtherCAT Slave Terminal settings to those on the Virtual SD Memory Card in the Industrial PC. Also, you can back up, restore, and compare the settings to settings in a designated folder on your computer.

This allows you to reduce the recovery time when an error occurs in the equipment.

- **Performing Wiring Checks between NX Units and I/O Devices from the Sysmac Studio Connected to the Peripheral USB Port on the EtherCAT Coupler Unit (Commissioning)**

You can use the I/O checking function to check the wiring between NX Units and I/O devices from the Sysmac Studio connected to the peripheral USB port on the EtherCAT Coupler Unit.

This allows you to check wiring in the following cases.

- You can check the wiring between NX Units and I/O devices in advance during system commissioning when the CPU Unit or Industrial PC is temporarily not available.
- You can check the wiring between NX Units and I/O devices in advance during system commissioning when EtherCAT network wiring is not completed.
- You can check the wiring between NX Units and I/O devices from close to the EtherCAT Slave Terminal.
- More than one person can simultaneously check wiring between NX Units and I/O devices when there is more than one EtherCAT Slave Terminal.

## Fail-soft Operation

Fail-soft operation is provided so that the EtherCAT Coupler Unit can start or continue I/O refreshing only with the NX Units that can operate normally when an error occurs for the EtherCAT Slave Terminal.

You can use fail-soft operation in the following cases.

- When it is dangerous to stop the entire EtherCAT Slave Terminal all at once
- To continue the operation of the EtherCAT Slave Terminal until the system can be stopped safely through the user program or user operation
- To not stop all devices, i.e., to continue operation for only some devices

## 2-2 System Configurations of EtherCAT Slave Terminals

This section describes the system configuration of an EtherCAT Slave Terminal.

### 2-2-1 System Configuration

An example of a system configuration for an EtherCAT Slave Terminal is shown below.

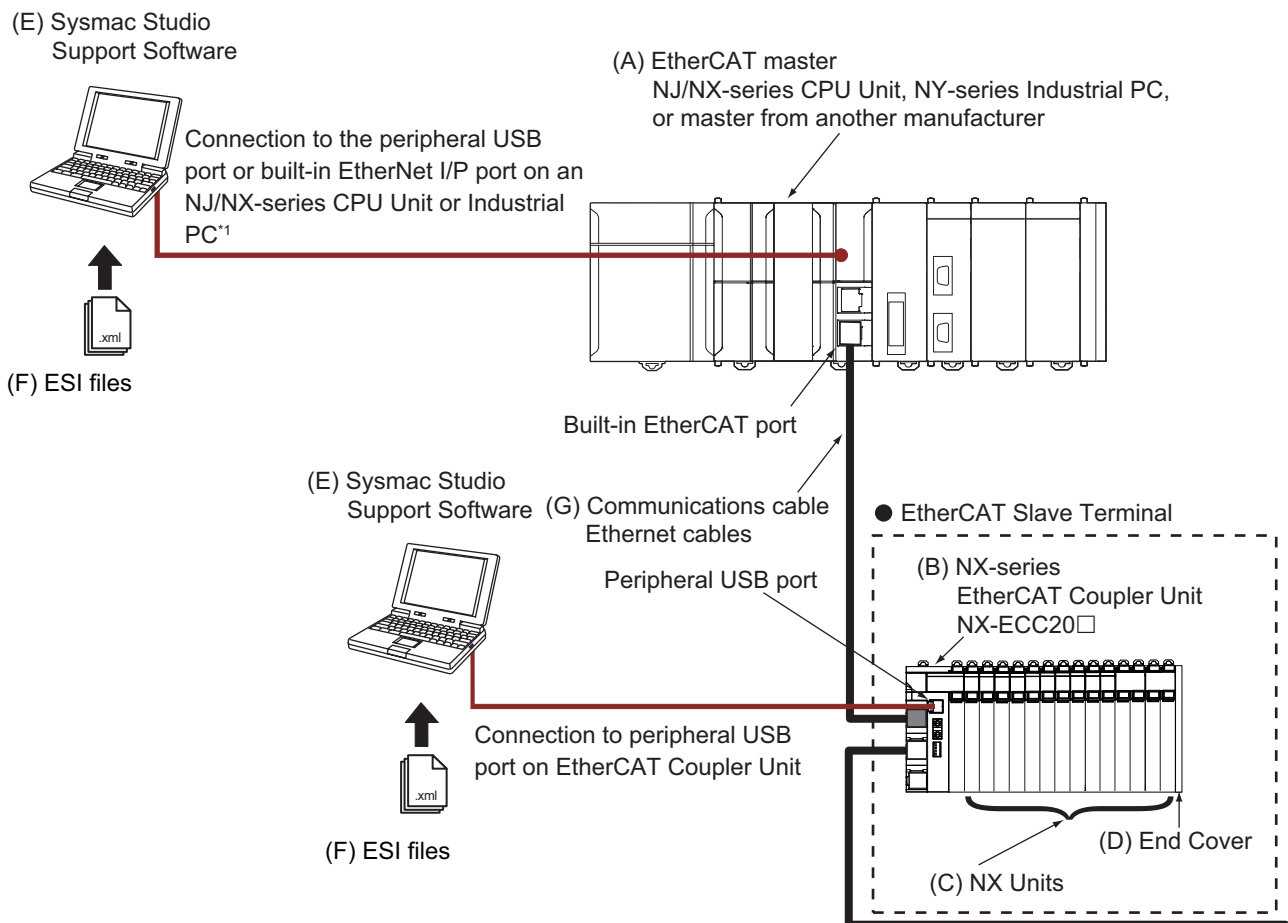

\*1. The connection method for the Sysmac Studio depends on the model of the CPU Unit or Industrial PC.

Letter	Item	Description
(A)	EtherCAT master*1	The EtherCAT master manages the EtherCAT network, monitors the status of the slaves, and exchanges I/O data with the slaves.
(B)	EtherCAT Coupler Unit	The EtherCAT Coupler Unit is an interface that performs process data communications between a group of NX Units and the EtherCAT master over an EtherCAT network. The I/O data for the NX Units is first accumulated in the EtherCAT Coupler Unit and then all of the data is exchanged with the EtherCAT master at the same time. The EtherCAT Coupler Unit can also perform message communications (SDO communications) with the EtherCAT master. You can connect up to 63 NX Units.

Letter	Item	Description
(C)	NX Units* <sup>2</sup>	The NX Units perform I/O processing with connected external devices. The NX Units perform process data communications with the EtherCAT master through the EtherCAT Coupler Unit. Refer to 2-2-2 <i>Types of NX Units</i> on page 2-8 for the types of NX Units.
(D)	End Cover	The End Cover is attached to the end of the Slave Terminal.
(E)	Sysmac Studio Support Software* <sup>3</sup> * <sup>4</sup> (Sysmac Studio)	The Sysmac Studio runs on a personal computer and it is used to configure the EtherCAT network and EtherCAT Slave Terminals, and to perform programming, monitoring, and troubleshooting. You can connect the computer, in which the Sysmac Studio is installed, to the peripheral USB port or built-in EtherNet/IP port on an NJ/NX-series CPU Unit or NY-series Industrial PC to set up the EtherCAT Slave Terminal. However, the usable connection methods depend on the model of the CPU Unit or Industrial PC. Or you can connect it to the peripheral USB port on the EtherCAT Coupler Unit to set up the EtherCAT Slave Terminal. Refer to 2-3 <i>Support Software</i> on page 2-10 for the connection procedure.
(F)	ESI (EtherCAT Slave Information) file	The ESI file contains information that is unique to the EtherCAT Slave Terminal in XML format. You can load the ESI file into the Sysmac Studio to easily allocate Slave Terminal process data and make other settings. The ESI files for OMRON EtherCAT slaves are already installed in the Sysmac Studio. You can update the Sysmac Studio to get the ESI files for the most recent models.
(G)	Communications cable	Use a double-shielded cable with aluminum tape and braiding of category 5 (100BASE-TX) or higher, and use straight wiring.

- \*1. Refer to A-11-1 *Relationship between Unit Versions* on page A-102 for information on the unit versions of CPU Units or Industrial PCs when you connect an EtherCAT Slave Terminal to the built-in EtherCAT port on an OMRON CPU Unit or Industrial PC.  
An EtherCAT Slave Terminal cannot be connected to any of the OMRON CJ1W-NC□81/□82 Position Control Units even though they can operate as EtherCAT masters.
- \*2. For whether an NX Unit can be connected to the EtherCAT Coupler Unit, refer to the version information in the user's manual for the NX Unit.
- \*3. Refer to A-11-1 *Relationship between Unit Versions* on page A-102 for information on the versions of the Sysmac Studio that you can use to set up EtherCAT Slave Terminals.
- \*4. The term Support Software indicates software that is provided by OMRON. If you connect to a master from another company, use the software tool corresponding to that master.

## 2-2-2 Types of NX Units

The following table lists some examples of the types of NX Units that are available.

Unit type	Overview
Digital I/O Units	These Units process I/O with digital signals.
Digital Input Units	These Units process inputs with digital signals.
Digital Output Units	These Units process outputs with digital signals.
Digital Mixed I/O Units	These Units process both inputs and outputs with digital signals.
Analog I/O Units	These Units process I/O with analog signals.
Analog Input Units	These Units process inputs with analog signals.
Analog Output Units	These Units process outputs with analog signals.
Temperature Input Units	These Units process inputs from temperature sensors.
Heater Burnout Detection Units	Heater Burnout Detection Units have the following functions. <ul style="list-style-type: none"> <li>• Monitoring of CT currents to provide alarms for heater burnouts and SSR failures</li> <li>• Time-proportional control output processing to operate heaters with SSRs</li> </ul>
System Units	System Units are used as required to build a Slave Terminal.
Additional NX Unit Power Supply Unit	This Unit is used when the NX Unit power supply is not sufficient.
Additional I/O Power Supply Unit	This Unit is used when the I/O power supply is not sufficient or to separate the power supply in the Slave Terminal.
I/O Power Supply Connection Unit	This Unit is used when the I/O power supply terminals for connections to external I/O devices are not sufficient.
Shield Connection Unit	This Unit is used to ground more than one shield wire from external I/O connections to the same ground.
Position Interface Units	These Units perform I/O processing of position data for positioning.
Incremental Encoder Input Units	These Units count pulses from incremental encoders.
SSI Input Units	These Units process serial signal inputs from absolute encoders or linear scales that have an SSI interface.
Pulse Output Unit	This Unit outputs pulses for positioning commands to a stepper motor driver or other motor drive with a pulse input.
Load Cell Input Unit	This Unit performs input processing of the output signal from a load cell to measure the weight or force.
IO-Link Master Unit	This Unit uses IO-Link communications to perform I/O processing for IO-Link devices. It also supports I/O processing of digital signals from non-IO-Link-devices.
Communications Interface Units	These Units support serial communications. Both RS-232C and RS-422A/485 are supported as the serial interface.
Temperature Control Unit	This Unit receives signals from the temperature sensor and controls the heater temperature to match the set temperature.
Safety Control Units	The NX-series Safety Control Units constitute a programmable safety controller that complies with IEC 61131-3 and PLCopen® TC5 Safety. They include Safety CPU Units and Safety I/O Units.
Safety CPU Unit	This Unit controls the Safety I/O Units through the NX bus and EtherCAT.
Safety I/O Units	These Units enable safety inputs or safety outputs.

Refer to the user's manual for the specific Units for details.

For information on the most recent lineup of NX Units, refer to *NX-series catalogs* or OMRON websites, or ask your OMRON representative.

### 2-2-3 Safety Control System

Refer to the *NX-series Safety Control Unit User's Manual (Cat. No. Z930)* for details on safety control systems built with Safety Control Units.

## 2-3 Support Software

This section describes the Support Software that is used to set up the EtherCAT Slave Terminal.

### 2-3-1 Applicable Support Software

Refer to *A-11-1 Relationship between Unit Versions* on page A-102 for information on the versions of the Support Software that you can use to set up EtherCAT Slave Terminals.

### 2-3-2 Connection Method and Procedures

This section describes the methods and procedures that are used to connect the Sysmac Studio to an EtherCAT Slave Terminal.

#### Going Online with a CPU Unit or an Industrial PC

This section describes the methods and procedures for placing the Sysmac Studio online with an NJ/NX-series CPU Unit or NY-series Industrial PC.

##### ● Connection Methods

You can place the Sysmac Studio online with an EtherCAT Slave Terminal through a CPU Unit or an Industrial PC.

There are the following four methods that you can use, based on the connection configuration, to place the Sysmac Studio online with a CPU Unit or an Industrial PC.

- Direct connection via USB
- Direct connection via Ethernet
- Remote connection via USB
- Ethernet connection via a hub

However, the usable connection methods depend on the model of the CPU Unit or Industrial PC.

For details on the methods for placing the Sysmac Studio online with the CPU Unit or the Industrial PC, refer to the hardware user's manual for the connected CPU Unit or Industrial PC.

##### ● Connection Procedures

Refer to *Going Online with a Controller* in the *Sysmac Studio Version 1 Operation Manual (Cat. No. W504)* for details on placing the Sysmac Studio online.

#### Going Online through the USB Port on the EtherCAT Coupler Unit

##### ● Connection Methods

You can place the Sysmac Studio online with the EtherCAT Slave Terminal without going through a CPU Unit or an Industrial PC.

Connect the Sysmac Studio to the USB port on the EtherCAT Coupler Unit.

When the Sysmac Studio is placed online with the CPU Unit or Industrial PC, some functions are not available. Refer to *A-2-1 Functional Differences on the Sysmac Studio Based on the Connected Port* on page A-5 for details.

## ● Connection Procedure

Use the following procedure to place the Sysmac Studio online.

- 1 Connect the EtherCAT Coupler Unit to a computer in which the Sysmac Studio is installed through a USB cable.
- 2 Create a project for the NJ/NX/NY-series Controller on the Sysmac Studio, and then create a configuration for the EtherCAT Slave Terminal. Refer to *9-2-3 Setting the Unit Configuration Information* on page 9-10 for the procedures for creating the Unit configuration information.
- 3 Right-click the EtherCAT Coupler Unit in the Edit EtherCAT Slave Terminal Configuration Tab Page, and select **Coupler Connection (USB) – Online**. Or, right-click the EtherCAT Coupler Unit in the Multiview Explorer and select **Coupler Connection (USB) – Online**. A confirmation dialog box is displayed.
- 4 Click the **OK** Button.  
The Sysmac Studio goes online with the EtherCAT Slave Terminal.

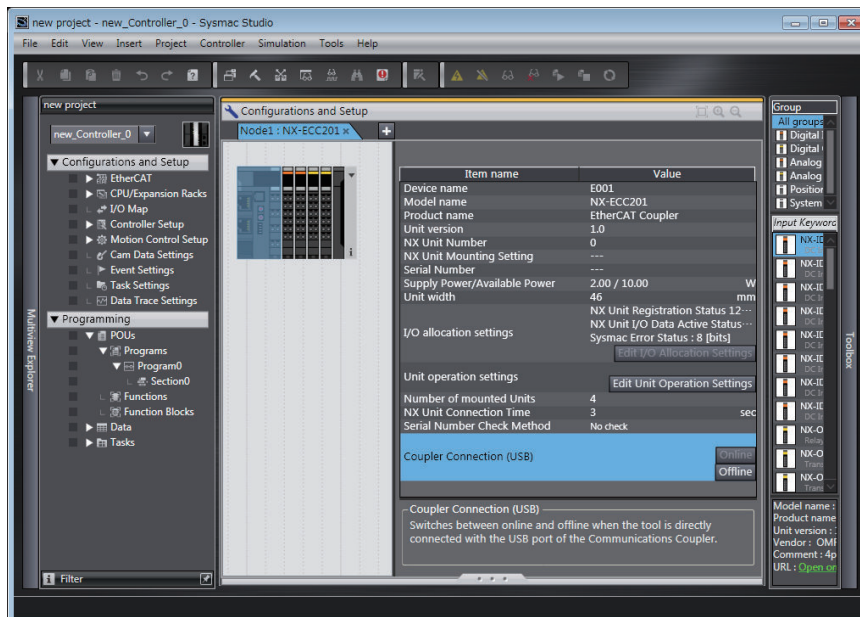

### 2-3-3 Scope of Access When Connected to the USB Port on the EtherCAT Coupler Unit

The scope of access from the Sysmac Studio when it is connected to the USB port on the EtherCAT Coupler Unit is limited to the EtherCAT Slave Terminal at the connection. Sysmac Studio cannot access any Units that are not at the connection (such as the CPU Unit, Industrial PC, other EtherCAT slaves, or other EtherCAT Slave Terminals).

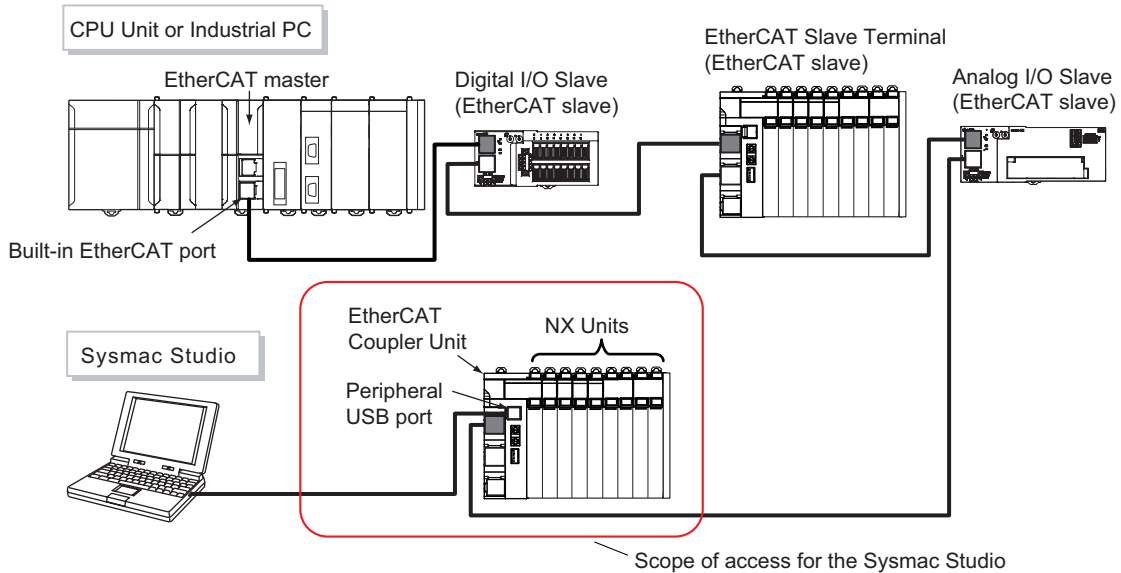

# 3

## Specifications and Application Procedures

This section provides the general specifications of the EtherCAT Slave Terminal, the specifications of the EtherCAT Coupler Unit and End Cover, and the applications procedures for the EtherCAT Slave Terminal.

---

<b>3-1</b>	<b>Specifications</b> .....	<b>3-2</b>
3-1-1	General Specifications of EtherCAT Slave Terminals .....	3-2
3-1-2	EtherCAT Coupler Unit Specifications .....	3-2
3-1-3	End Cover Specifications .....	3-6
<b>3-2</b>	<b>Procedures</b> .....	<b>3-7</b>
3-2-1	EtherCAT Slave Terminal Application Procedures .....	3-7
3-2-2	Details .....	3-9

## 3-1 Specifications

This section provides the general specifications of an EtherCAT Slave Terminal and the specifications of the EtherCAT Coupler Unit and End Cover.

### 3-1-1 General Specifications of EtherCAT Slave Terminals

Item		Specification
Enclosure		Mounted in a panel
Grounding method		Ground to 100 Ω or less.
Operating environment	Ambient operating temperature	0 to 55°C
	Ambient operating humidity	10% to 95% (with no condensation or icing)
	Atmosphere	Must be free from corrosive gases.
	Ambient storage temperature	-25 to 70°C (with no condensation or icing)
	Altitude	2,000 m max.
	Pollution degree	2 or less: Meets IEC 61010-2-201.
	Noise immunity	2 kV on power supply line (Conforms to IEC 61000-4-4.)
	Overvoltage category	Category II: Meets IEC 61010-2-201.
	EMC immunity level	Zone B
	Vibration resistance	Conforms to IEC 60068-2-6. 5 to 8.4 Hz with 3.5-mm amplitude, 8.4 to 150 Hz, acceleration of 9.8 m/s <sup>2</sup> , 100 min each in X, Y, and Z directions (10 sweeps of 10 min each = 100 min total) <sup>*1</sup>
Shock resistance	Conforms to IEC 60068-2-27. 147 m/s <sup>2</sup> , 3 times each in X, Y, and Z directions <sup>*1</sup>	
Applicable standards <sup>*2</sup>		cULus: Listed (UL508 or UL61010-2-201), ANSI/ISA 12.12.01 EU: EN 61131-2, C-Tick, or RCM KC (KC Registration), NK, and LR

\*1. Refer to the *NX-series Digital I/O Units User's Manual (Cat. No. W521)* for the vibration and shock resistance specifications of the Relay Output Unit.

\*2. Refer to the OMRON website (<http://www.ia.omron.com/>) or consult your OMRON representative for the most recent applicable standards for each model.

### 3-1-2 EtherCAT Coupler Unit Specifications

Item	Specification		
	NX-ECC201	NX-ECC202	NX-ECC203
Number of connectable NX Units	63 Units max. <sup>*1</sup>		
Communications protocol	EtherCAT protocol		
Modulation	Baseband		
Baud rate	100 Mbps		
Physical layer	100BASE-TX (IEEE 802.3)		

Item	Specification		
	NX-ECC201	NX-ECC202	NX-ECC203
<b>Topology</b>	Depends on the specifications of the EtherCAT master.*2		
<b>Transmission media</b>	Category 5 or higher twisted-pair cable (Recommended cable: double-shielded cable with aluminum tape and braiding)		
<b>Transmission distance</b>	Distance between nodes: 100 m or less		
<b>Send/receive PDO data sizes</b>	Input: 1,024 bytes max. (including input data, status, and unused areas) Output: 1,024 bytes max. (including output data and unused areas)		
<b>Mailbox data size</b>	Input: 256 bytes Output: 256 bytes		
<b>Mailbox</b>	Emergency messages and SDO requests		
<b>Refreshing methods*3</b>	<ul style="list-style-type: none"> <li>Free-Run refreshing</li> <li>Synchronous I/O refreshing</li> <li>Time stamp refreshing</li> </ul>	<ul style="list-style-type: none"> <li>Free-Run refreshing</li> <li>Synchronous I/O refreshing</li> <li>Time stamp refreshing</li> <li>Task period prioritized refreshing</li> </ul>	
<b>Node address setting range</b>	When the settable node address range for the built-in EtherCAT port is 1 to 512*4 <ul style="list-style-type: none"> <li>Set on switches: 1 to 199</li> <li>Set with the Sysmac Studio: 1 to 512</li> </ul> When the settable node address range for the built-in EtherCAT port is 1 to 192*3 <ul style="list-style-type: none"> <li>Set on switches: 1 to 192</li> <li>Set with the Sysmac Studio: 1 to 192</li> </ul>		
<b>I/O jitter performance</b>	Inputs: 1 μs max. Outputs: 1 μs max.		
<b>Communications cycle in DC Mode</b>	250 to 4,000 μs*5*6		125 to 10,000 μs*4*5*7
<b>Communications cycle in Free-Run Mode</b>	There are no restrictions with the exception of some combinations with NX Units.*4*6		
<b>Unit power supply</b>	<b>Power supply voltage</b>	24 VDC (20.4 to 28.8 VDC)	
	<b>NX Unit power supply capacity</b>	10 W max. Refer to <i>Installation orientation and restrictions</i> on page 3-4 for details.	
	<b>NX Unit power supply efficiency</b>	70%	
	<b>Isolation method</b>	No isolation between NX Unit power supply and Unit power supply terminals	
	<b>Current capacity of power supply terminals</b>	4 A max.	
<b>I/O power supply</b>	<b>Power supply voltage</b>	5 to 24 VDC (4.5 to 28.8 VDC)*8	
	<b>Maximum I/O power supply current</b>	4 A	10 A
	<b>Current capacity of power supply terminals</b>	4 A max.	10 A max.

Item	Specification		
	NX-ECC201	NX-ECC202	NX-ECC203
<b>NX Unit power consumption</b>	1.45 W max.		1.25 W max.
<b>Current consumption from I/O power supply</b>	10 mA max. (for 24 VDC)		
<b>Dielectric strength</b>	510 VAC for 1 min, leakage current: 5 mA max. (between isolated circuits)		
<b>Insulation resistance</b>	100 VDC, 20 MΩ min. (between isolated circuits)		
<b>External connection terminals</b>	Communications Connector For EtherCAT communications.		
	<ul style="list-style-type: none"> <li>• RJ45 × 2 (shielded)</li> <li>• IN: EtherCAT input data, OUT: EtherCAT output data</li> </ul>		
	Screwless Clamping Terminal Block For Unit power supply, I/O power supply, and grounding. Removable.		
<b>Dimensions</b>	Peripheral USB Port For Sysmac Studio connection.		
	<ul style="list-style-type: none"> <li>• Physical layer: USB 2.0-compliant, B-type connector</li> <li>• Transmission distance: 5 m max.</li> </ul>		
<b>Weight</b>	46 × 100 × 71 mm (W×H×D)		
<b>Installation orientation and restrictions</b>	170 g max.		
<b>Installation orientation and restrictions</b>	Installation orientation: 6 possible orientations		
	Restrictions:		
	<ul style="list-style-type: none"> <li>• Used in the upright installation orientation.</li> </ul>		
<b>Installation orientation and restrictions</b>	<p>Output power [W]</p> <p>Ambient temperature [°C]</p> <p>10-W output, 40°C</p> <p>8.5-W output, 55°C</p>		
	<ul style="list-style-type: none"> <li>• Used in another orientation other than the upright installation orientation.</li> </ul>		
	<p>Output power [W]</p> <p>Ambient temperature [°C]</p> <p>10-W output, 40°C</p> <p>6.0-W output, 55°C</p>		

Item	Specification		
	NX-ECC201	NX-ECC202	NX-ECC203
<b>Circuit layout</b>			
<b>Terminal arrangement</b>			
<b>Accessory</b>	End Cover (NX-END01): 1		

- \*1. For the number of Safety Control Units that can be connected, refer to *System Configuration and Configuration Devices* and *Number of safety I/O connections* provided for each Unit model in the *NX-series Safety Control Unit User's Manual (Cat. No. Z930)*.
- \*2. The EtherCAT Coupler Unit conforms to EtherCAT standards. Confirm the specifications of the connected EtherCAT master for the support topology. The NX-ECC203 EtherCAT Coupler Unit with unit version 1.5 or later supports a ring topology.
- \*3. This function was added or improved for a version upgrade. Refer to *A-11 Version Information* on page A-102 for information on version upgrades.
- \*4. The range of node addresses that can be set depends on the model of the built-in EtherCAT port. For the node address ranges that can be set for a built-in EtherCAT port, refer to *Specifications of Built-in EtherCAT Port* in the user's manual for the built-in EtherCAT port on the connected CPU Unit or Industrial PC.
- \*5. This depends on the specifications of the EtherCAT master. For example, the values are as follows when the EtherCAT Coupler Unit is connected to the built-in EtherCAT port on an NJ5-series CPU Unit: 500 μs, 1,000 μs, 2,000 μs, and 4,000 μs. For the specifications of the built-in EtherCAT port, refer to the user's manual for the built-in EtherCAT port on the connected CPU Unit or the Industrial PC.
- \*6. This depends on the Unit configuration.
- \*7. There are restrictions in the communications cycles that you can set for some of the NX Units. If you use any of those NX Units, set a communications cycle that will satisfy the specifications for the refresh cycles that can be executed by the NX Unit. Refer to the appendix of the *NX-series Data Reference Manual (Cat. No. W525)* to see if there are restrictions on any specific NX Units. For information on the communications cycles that you can set, refer to the user's manuals for the NX Units.
- \*8. Use a voltage that is appropriate for the I/O circuits of the NX Units and the connected external devices.

**3-1-3 End Cover Specifications**

Item	Specification
<b>Model</b>	NX-END01
<b>Dimensions</b>	12 × 100 × 71 (W×H×D)
<b>Weight</b>	35 g max.

## 3-2 Procedures

This section describes how to use EtherCAT Slave Terminals.

Refer to the *NX-series Safety Control Unit User's Manual (Cat. No. Z930)* for the procedures to use Safety Control Units.

You can also use the I/O checking function to check the I/O wiring between NX Units and I/O devices for individual EtherCAT Slave Terminals. This allows you to check the wiring between NX Units and I/O devices before you perform all of the following procedures. Refer to *11-10 I/O Checking* on page 11-35 for details on I/O checking.

### 3-2-1 EtherCAT Slave Terminal Application Procedures

Procedure	Sections
1. Preparing for Work	<ul style="list-style-type: none"> <li>• 2-2-2 <i>Types of NX Units</i> on page 2-8</li> <li>• 3-1 <i>Specifications</i> on page 3-2</li> <li>• Section 5 <i>Designing the Power Supply System</i> on page 5-1</li> <li>• 6-1-3 <i>Installation Orientation</i> on page 6-8</li> <li>• 10-3-3 <i>Selecting NX Units</i> on page 10-10</li> </ul>
2. Making Hardware Settings and Wiring the Slave Terminal	<ul style="list-style-type: none"> <li>• 4-3 <i>Hardware Switch Settings</i> on page 4-11</li> <li>• 6-1 <i>Installing Units</i> on page 6-2</li> <li>• Section 7 <i>Wiring</i> on page 7-1</li> </ul>
3. Creating the EtherCAT Network Configuration and Making Settings as an EtherCAT Slave	9-2-2 <i>Settings as an EtherCAT Slave</i> on page 9-7
4. Configuring the Slave Terminal and Making the Operation Settings	<ul style="list-style-type: none"> <li>• <i>Slave Terminal Configuring and Operation Settings</i> on page 9-6</li> <li>• 9-2-3 <i>Setting the Unit Configuration Information</i> on page 9-10</li> <li>• 9-2-4 <i>I/O Allocation Information</i> on page 9-15</li> <li>• 9-2-5 <i>Unit Operation Settings</i> on page 9-26</li> <li>• 9-2-6 <i>Unit Application Data</i> on page 9-28</li> </ul>
5. Setting EtherCAT Master Parameters	User's manual for the built-in EtherCAT port on the connected CPU Unit or Industrial PC



6. Assigning Slave Terminal Variables	<ul style="list-style-type: none"> <li>• <i>9-3 Assigning Variables</i> on page 9-37</li> <li>• <i>9-3-2 Assigning Device Variables to I/O Ports</i> on page 9-38</li> <li>• <i>9-3-4 Assigning Axis Variables</i> on page 9-40</li> </ul>
---------------------------------------	--



7. Programming	<ul style="list-style-type: none"> <li>• Software user's manual for the connected CPU Unit or Industrial PC</li> <li>• User's manual for the built-in EtherCAT port on the connected CPU Unit or Industrial PC</li> <li>• <i>10-3-5 Setting the Task Periods of Periodic Tasks</i> on page 10-18</li> <li>• <i>10-3-6 Task Allocations</i> on page 10-22</li> </ul>
----------------	---



8. Turning ON Power and Going Online from the Sysmac Studio	<ul style="list-style-type: none"> <li>• <i>4-2 Indicators</i> on page 4-6</li> <li>• <i>Sysmac Studio Version 1 Operation Manual (Cat. No. W504)</i></li> </ul>
---	--



9. Comparing and Merging with the Actual Network Configuration or the Actual Unit Configuration	<ul style="list-style-type: none"> <li>• <i>9-2-7 Sysmac Studio Functions Used as Required</i> on page 9-28</li> <li>• User's manual for the built-in EtherCAT port on the connected CPU Unit or Industrial PC</li> </ul>
---	---



10. Downloading the Network Configuration Information, the Slave Terminal Setting Information, and the User Program	<ul style="list-style-type: none"> <li>• <i>9-4 Transferring and Comparing Settings</i> on page 9-42</li> </ul>
---	---



11. Checking Indicators	<ul style="list-style-type: none"> <li>• User's manual for the built-in EtherCAT port on the connected CPU Unit or Industrial PC</li> <li>• <i>4-2 Indicators</i> on page 4-6</li> </ul>
-------------------------	--



12. Confirming Operation by Checking the Wiring

- Manuals for the specific NX Units
- *11-10 I/O Checking* on page 11-35

### 3-2-2 Details

Procedure	Item	Description	Reference	
1	Preparing for Work	Selecting NX Units  Confirming Suitability of Slave Terminal Specifications	Select the NX Units for I/O refreshing methods, and the quantity and types of I/O that are required.  Confirm that the following specific restrictions for the Slave Terminal are met. <ul style="list-style-type: none"> <li>• Number of NX Units</li> <li>• Send/receive PDO data sizes</li> <li>• Design conditions for the NX Unit power supply and I/O power supply</li> <li>• Installation orientation</li> </ul>	<ul style="list-style-type: none"> <li>• <i>2-2-2 Types of NX Units</i> on page 2-8</li> <li>• <i>10-3-3 Selecting NX Units</i> on page 10-10</li> <li>• <i>3-1 Specifications</i> on page 3-2</li> <li>• <i>Section 5 Designing the Power Supply System</i> on page 5-1</li> <li>• <i>6-1-3 Installation Orientation</i> on page 6-8</li> </ul>
	Making Hardware Settings and Wiring the Slave Terminal	Setting the Node Address  Installation  Wiring	Set the node address of the EtherCAT Coupler Unit with the hardware switches. You can also use the Sysmac Studio to set the node address with software settings. To use software settings, set the hardware switches to 000, install and wire the Slave Terminal, and then set the software settings in step 8.  Connect the NX Units and End Cover to the EtherCAT Coupler Unit and secure the Slave Terminal to a DIN Track to install it.  Wire the Slave Terminal. <ul style="list-style-type: none"> <li>• Connect the communications cables.</li> <li>• Connect the Unit power supply.</li> <li>• Connect the I/O power supply.</li> <li>• Connect the ground wire.</li> <li>• Connect the external I/O devices.</li> </ul>	<i>4-3 Hardware Switch Settings</i> on page 4-11  <i>6-1 Installing Units</i> on page 6-2  <i>Section 7 Wiring</i> on page 7-1
3	Creating the EtherCAT Network Configuration and Making Settings as an EtherCAT Slave	Creating the EtherCAT Network Configuration and Making Settings as an EtherCAT Slave	Create a project in the Sysmac Studio. Create the EtherCAT network configuration offline. Specifically, register the EtherCAT Coupler Unit in the network configuration. Then, make the settings for the EtherCAT Coupler Unit as an EtherCAT slave. Set the node address of the EtherCAT Coupler Unit to the node address set in step 2. Set other parameters as required.  If you want to use the compare and merge operation to automatically create the EtherCAT network configuration online based on the actual devices that are connected to the network, you must use step 8 first to go online. After the network configuration is created automatically, go offline and set the other parameters.	<i>9-2-2 Settings as an EtherCAT Slave</i> on page 9-7

Procedure	Item	Description	Reference	
4	Configuring the Slave Terminal and Making the Operation Settings	Set up the Slave Terminal (create the configuration and set the parameters) on the Edit Slave Terminal Configuration Tab Page on the Sysmac Studio.	<i>Slave Terminal Configuring and Operation Settings</i> on page 9-6	
	Creating the Unit Configuration Information	Create the Unit configuration information of the Slave Terminal offline. The Unit configuration information includes the EtherCAT Coupler Unit and the NX Units.	<i>9-2-3 Setting the Unit Configuration Information</i> on page 9-10	
	Setting the I/O Allocation Information	Make the I/O allocations for the EtherCAT Coupler Unit and NX Units as required.	<i>9-2-4 I/O Allocation Information</i> on page 9-15	
	Unit Operation Settings	Make the Unit operation settings for the EtherCAT Coupler Unit and NX Units as required.	<i>9-2-5 Unit Operation Settings</i> on page 9-26	
	Setting Unit Application Data	Create the Unit application data. This step applies only to Units that have Unit application data.	<i>9-2-6 Unit Application Data</i> on page 9-28	
5	Setting EtherCAT Master Parameters	Setting EtherCAT Master Parameters	Set the process data communications cycle, wait time for slave startup, and other parameters for the EtherCAT master. The values that are set are reflected in the network configuration information.	User's manual for the built-in EtherCAT port on the connected CPU Unit or Industrial PC
6	Assigning Slave Terminal Variables	To enable access in the user program in the NJ/NX-series Unit or the NY-series Industrial PC, the I/O data that is assigned in the I/O allocation information is assigned to device variables and axis variables.	<i>9-3 Assigning Variables</i> on page 9-37	
	Assigning Device Variables to I/O Ports	If necessary, change the names of automatically generated device variables for each I/O port to user-defined variable names.	<i>9-3-2 Assigning Device Variables to I/O Ports</i> on page 9-38	
	Assigning Axis Variables	If you will control Position Interface Units with the Motion Control Function Module, create the axes and assign I/O data to the axis variables.	<i>9-3-4 Assigning Axis Variables</i> on page 9-40	
7	Programming	Programming	Write the user program with device variables and axis variables.	<ul style="list-style-type: none"> <li>• Software user's manual for the connected CPU Unit or Industrial PC</li> <li>• User's manual for the built-in EtherCAT port on the connected CPU Unit or Industrial PC</li> </ul>
	Task Settings	Make the task settings. Assign a task to each EtherCAT Slave Terminal. If you will use DC Mode to refresh I/O for EtherCAT Slave Terminals after you assigned tasks, set the task period of the assigned periodic task so that it is longer than the refresh cycle of the NX bus.	<ul style="list-style-type: none"> <li>• Software user's manual for the connected CPU Unit or Industrial PC</li> <li>• <i>10-3-5 Setting the Task Periods of Periodic Tasks</i> on page 10-18</li> <li>• <i>10-3-6 Task Allocations</i> on page 10-22</li> </ul>	

Procedure	Item	Description	Reference	
8	Turning ON Power and Going Online from the Sysmac Studio	Turning ON the Unit Power Supply to the Slave Terminal	Turn ON the Unit power supply to the EtherCAT Coupler Unit. If there are any Additional NX Unit Power Supply Units, turn ON the Unit power supply to the Additional NX Unit Power Supply Units at the same time as the Unit power supply to the EtherCAT Coupler Unit. When you do, the Unit configuration information does not exist in the EtherCAT Coupler Unit yet, so the TS indicator on the EtherCAT Coupler Unit will flash green.	4-2 <i>Indicators</i> on page 4-6
		Turning ON the I/O Power Supply to the Slave Terminal	Turn ON the I/O power supply to the EtherCAT Coupler Unit. If there are any Additional I/O Power Supply Units, turn ON the I/O power supply to the Additional I/O Power Supply Units at the same time as the I/O power supply to the Ether-CAT Coupler Unit.	---
		Turning ON the Power Supply to the NJ/NX/NY-series Controller	Turn ON the power supply to the NJ/NX/NY-series Controller.	---
		Online connection from Sysmac Studio	Use the Sysmac Studio to set communications with the NJ/NX/NY-series Controller and go online.	<i>Sysmac Studio Version 1 Operation Manual (Cat. No. W504)</i>
9	Comparing and Merging with the Actual Network Configuration or the Actual Unit Configuration	Comparing and Merging with the Actual Network Configuration or the Actual Unit Configuration	Use the compare and merge operation for the physical configurations to see if the EtherCAT network configuration and EtherCAT Slave Terminal Unit configuration that are set on the Sysmac Studio agree with the actual configurations.	<ul style="list-style-type: none"> <li>9-2-7 <i>Sysmac Studio Functions Used as Required</i> on page 9-28</li> <li>User's manual for the built-in EtherCAT port on the connected CPU Unit or Industrial PC</li> </ul>
10	Downloading the Network Configuration Information, the Slave Terminal Setting Information, and the User Program	Downloading the Network Configuration Information, the Slave Terminal Setting Information, and the User Program	Download the network configuration information, Slave Terminal setting information, and user program. Use the <i>synchronization</i> operation of the Sysmac Studio to download the data. The network configuration information contains the setting information of EtherCAT slaves. The Slave Terminal setting information contains the Unit configuration information, I/O allocation information, Unit operation settings, and Unit application data.	9-4 <i>Transferring and Comparing Settings</i> on page 9-42

Procedure	Item	Description	Reference
11	Checking Indicators	<p>Checking Indicators</p> <p>Check the indicators for the built-in EtherCAT port on the NJ/NX-series CPU Unit or NY-series Industrial PC. Also, check the indicators on the Units in the EtherCAT Slave Terminal.</p> <p>Check the following indicators on the EtherCAT Coupler Unit.</p> <ul style="list-style-type: none"> <li>• A solid green TS indicator indicates normal operating status.</li> <li>• A solid green RUN indicator shows the device is in the Operational state (normal communications state).</li> <li>• A flashing green LINK/ACT indicator shows that the link is established and data is being transmitted and received.</li> <li>• If the ERR indicator is not lit, there is no error.</li> </ul> <p>Check the following indicators on the NX Units.</p> <ul style="list-style-type: none"> <li>• A solid green TS indicator indicates normal operating status.</li> </ul>	<ul style="list-style-type: none"> <li>• User's manual for the built-in EtherCAT port on the connected CPU Unit or Industrial PC</li> <li>• 4-2 <i>Indicators</i> on page 4-6</li> </ul>
12	Confirming Operation by Checking the Wiring	<p>Confirming Operation by Checking the Wiring</p> <p>Use one of the following checking methods for the wiring on the NX Units to check operation.</p> <ul style="list-style-type: none"> <li>• Check the wiring by monitoring inputs or using forced refreshing of outputs from the I/O Map or Watch Tab Page on the Sysmac Studio.</li> <li>• To use the Motion Control Function Module to control Position Interface Units, use the MC Test Run from the Sysmac Studio or monitor the axis status from the MC monitor table to check the wiring.</li> <li>• Use the I/O checking function of the EtherCAT Slave Terminal to check the wiring between NX Units and I/O devices.</li> </ul>	<ul style="list-style-type: none"> <li>• Manuals for the specific NX Units</li> <li>• 11-10 <i>I/O Checking</i> on page 11-35</li> </ul>

# 4

## Part Names and Functions

This section gives the names of the parts of the EtherCAT Coupler Unit, NX Units, and End Cover and describes the functions of the parts.

4

---

<b>4-1</b>	<b>Parts and Names .....</b>	<b>4-2</b>
4-1-1	EtherCAT Coupler Units .....	4-2
4-1-2	NX Units .....	4-4
4-1-3	End Cover .....	4-5
<b>4-2</b>	<b>Indicators .....</b>	<b>4-6</b>
<b>4-3</b>	<b>Hardware Switch Settings .....</b>	<b>4-11</b>
4-3-1	Rotary Switches .....	4-11
4-3-2	DIP Switch .....	4-12
4-3-3	Setting the Node Address .....	4-13
<b>4-4</b>	<b>Communications Connector and Peripheral USB Port .....</b>	<b>4-14</b>
<b>4-5</b>	<b>Terminal Blocks .....</b>	<b>4-15</b>
<b>4-6</b>	<b>DIN Track Contact Plate .....</b>	<b>4-17</b>

## 4-1 Parts and Names

This section gives the names of the parts of the EtherCAT Coupler Unit, NX Units, and End Plates and describes the functions of the parts.

### 4-1-1 EtherCAT Coupler Units

This section gives the names of the parts of the EtherCAT Coupler Unit.

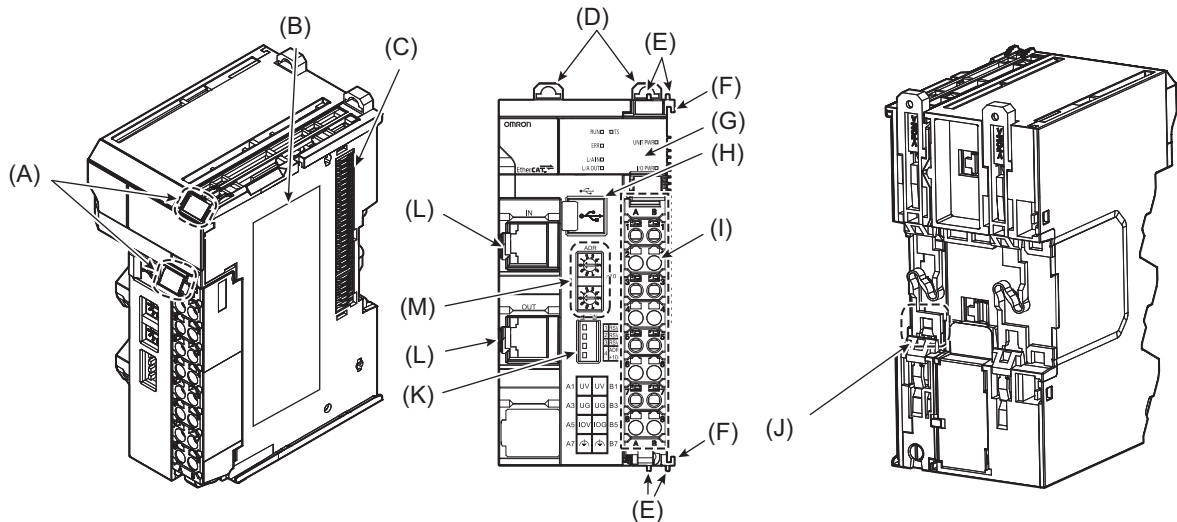

Letter	Name	Function
(A)	Marker attachment locations	The locations where markers are attached. The markers made by OMRON are installed for the factory setting. Commercially available markers can also be installed. For details, refer to 6-1-8 <i>Attaching Markers</i> on page 6-18.
(B)	Unit specifications	The specifications of the Unit are given.
(C)	NX bus connector	This connector is used to connect the EtherCAT Coupler Unit to the NX Unit on the right of the Coupler Unit.
(D)	DIN Track mounting hooks	These hooks are used to mount the EtherCAT Coupler Unit to a DIN Track.
(E)	Protrusions for removing the Unit	The protrusions to hold when removing the Unit.
(F)	Unit hookup guides	These guides are used to connect two Units.
(G)	Indicators	The indicators show the current operating status of the Unit and the status of the power supply.
(H)	Peripheral USB port	This port is used to connect to the Sysmac Studio.
(I)	Terminal block	The terminal block is used to connect to the power supply cables and ground wire.
(J)	DIN Track contact plate	This plate is connected internally to the functional ground terminal on the terminal block.
(K)	DIP switch	The DIP switch is used to set the 100s digit of the node address of the EtherCAT Coupler Unit as an EtherCAT slave.
(L)	Communications connectors	These connectors are connected to the communications cables of the EtherCAT network. There are two connectors: one for the input port and one for the output port.

Letter	Name	Function
(M)	Rotary switches	The rotary switches are used to set the 1s digit and 10s digit of the node address of the EtherCAT Coupler Unit as an EtherCAT slave. The address is set in decimal.

## 4-1-2 NX Units

This section provides an example of an NX Unit.

Refer to the user's manual for each NX Unit for specific information.

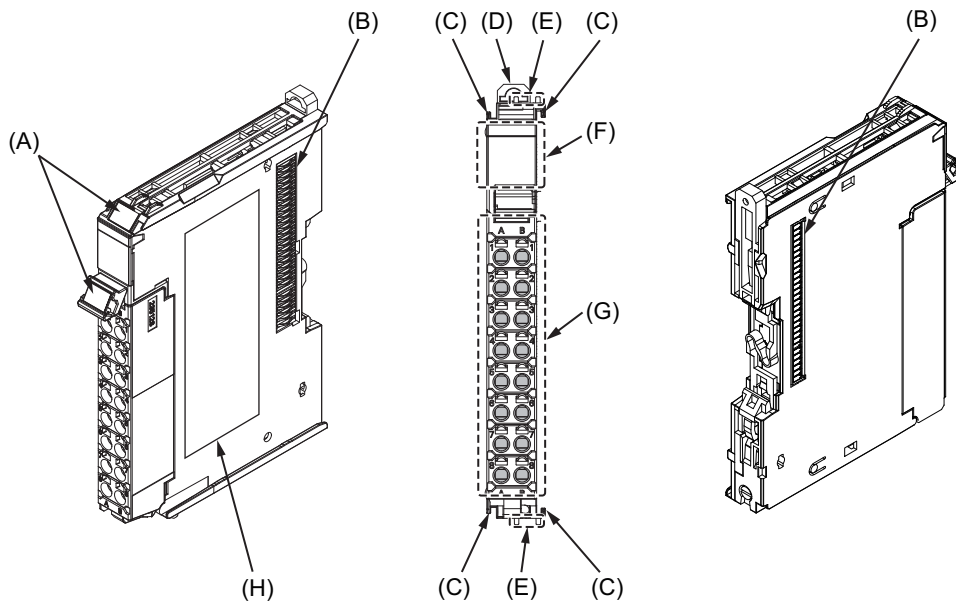

Letter	Name	Function
(A)	Marker attachment locations	The locations where markers are attached. The markers made by OMRON are installed for the factory setting. Commercially available markers can also be installed.
(B)	NX bus connector	This connector is used to connect each Unit.
(C)	Unit hookup guides	These guides are used to connect two Units.
(D)	DIN Track mounting hooks	These hooks are used to mount the NX Unit to a DIN Track.
(E)	Protrusions for removing the Unit	The protrusions to hold when removing the Unit.
(F)	Indicators	The indicators show the current operating status of the Unit.
(G)	Terminal block	The terminal block is used to connect external devices. The number of terminals depends on the type of Unit.
(H)	Unit specifications	The specifications of the Unit are given.

### 4-1-3 End Cover

An NX-END01 End Cover is connected to the end of the EtherCAT Slave Terminal. One End Cover is provided together with the EtherCAT Coupler Unit.

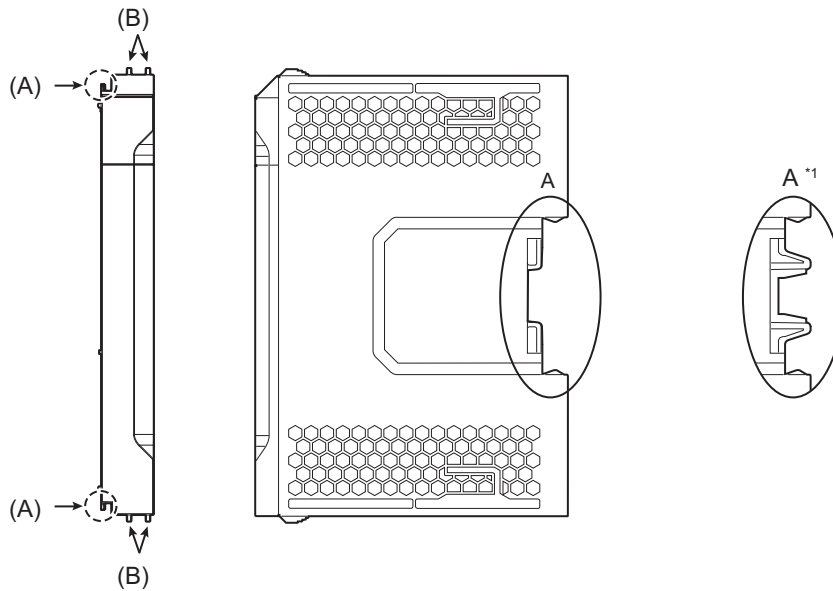

\*1. This is the shape for Units with lot numbers through December 2014.

Letter	Name	Function
(A)	Unit hookup guides	These guides are used to connect the End Cover to the NX Unit on the left of the End Cover.
(B)	Protrusions for removing the Unit	The protrusions to hold when removing the End Cover.



#### Precautions for Correct Use

Always mount an End Cover to the end of the EtherCAT Slave Terminal to protect the last NX Unit in the EtherCAT Slave Terminal. Not attaching the End Cover may result in malfunction or failure of the EtherCAT Slave Terminal.

## 4-2 Indicators

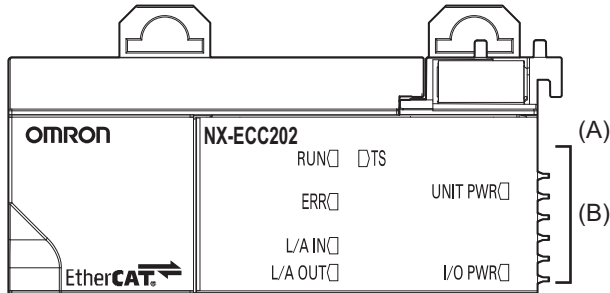

There are the indicators to show the current operating status of the Unit on the EtherCAT Coupler Unit. The appearance of the indicators has been changed for models released in or before September 2018 with lot numbers that represent the date of or after September 20, 2018. In this manual, those models are shown with the indicators after the change. For details on the applicable models and the changes, refer to *Appearance Change of the Indicators* on page 4-10.





Letter	Name	Function
(A)	Model number	The model number of the EtherCAT Coupler Unit is shown.
(B)	Indicators	The current operating status of the EtherCAT Coupler Unit is shown.

### TS Indicator



The TS indicator shows the status of the EtherCAT Coupler Unit and the communications status between the EtherCAT Coupler Unit and the NX Units.

Color	Status	Meaning
Green	 Lit.	The Unit is operating normally.
	 Flashing at 2-s intervals.	• Initializing
	 Flashing at 0.5-s intervals.	• Unit configuration information is not set. • I/O checking is in progress.

Color	Status	Meaning
Red	 Lit.	<ul style="list-style-type: none"> <li>• Hardware failure</li> <li>• Bus Controller Error</li> <li>• Non-volatile Memory Control Parameter Error</li> <li>• Unit Configuration Error</li> <li>• Unit Configuration Information Error</li> <li>• Unit Configuration Verification Error</li> <li>• ESC Error</li> <li>• ESC Initialization Error</li> <li>• Slave Unit Verification Error</li> <li>• Memory Corruption Detected</li> <li>• NX Unit Startup Error</li> <li>• Other error for which the EtherCAT Coupler Unit needs to be replaced.</li> </ul>
	 Flashing at 1-s intervals.	<ul style="list-style-type: none"> <li>• NX Unit Communications Timeout</li> <li>• NX Unit Initialization Error</li> <li>• Synchronization Interruption Error</li> <li>• Synchronization Error</li> <li>• Communications Synchronization Error</li> <li>• Process Data WDT Error</li> <li>• Errors related to EtherCAT communications settings</li> <li>• Illegal State Transition Request Received</li> <li>• Error State Transition Received</li> <li>• Synchronization Cycle Setting Error</li> </ul>
---	 Not lit.	<ul style="list-style-type: none"> <li>• There is insufficient or no Unit power supply.</li> <li>• Restarting is in progress for the Slave Terminal</li> <li>• Waiting for initialization to start.</li> </ul>



## UNIT PWR Indicator

The UNIT PWR indicator shows the status of the Unit power supply.

Color	Status	Meaning
Green	 Lit.	Power is currently supplied from the Unit power supply.
---	 Not lit.	No power is currently supplied.



## I/O PWR Indicator

The I/O PWR indicator shows the status of the I/O power supply.

Color	Status	Meaning
Green	 Lit.	Power is currently supplied from the I/O power supply.
---	 Not lit.	No power is currently supplied.



## L/A IN Indicator

The L/A IN indicator shows the status of the inputs in EtherCAT communications.

Color	Status		Meaning
Green		Lit.	A link was established in the physical layer.
		Flickering	A link was established and input communications are in operation.
---		Not lit.	A link was not established in the physical layer.



## L/A OUT Indicator

The L/A OUT indicator shows the status of the outputs in EtherCAT communications.

Color	Status		Meaning
Green		Lit.	A link was established in the physical layer.
		Flickering	A link was established and output communications are in operation.
---		Not lit.	A link was not established in the physical layer.

## RUN Indicator



The RUN indicator shows the operating status of EtherCAT communications for the EtherCAT Coupler Unit.

Color	Status		Meaning
Green		Lit.	Operational state
		Blinking	Pre-Operational state
		Single flash	Safe-Operational state
---		Not lit.	Init state

For details on EtherCAT states, refer to *8-3 Transitions of Communications States* on page 8-4.

## ERR Indicator

The ERR indicator provides information on errors in the EtherCAT Coupler Unit.

Color	Status	Meaning	
Red	 Lit.	<ul style="list-style-type: none"> <li>• Hardware failure</li> <li>• ESC Initialization Error</li> <li>• Other error for which the EtherCAT Coupler Unit needs to be replaced.</li> </ul>	
		Flickering	ESC Error
		Blinking	<ul style="list-style-type: none"> <li>• NX Unit Initialization Error</li> <li>• Bus Controller Error</li> <li>• Non-volatile Memory Control Parameter Error</li> <li>• Unit Configuration Error</li> <li>• Unit Configuration Information Error</li> <li>• Unit Configuration Verification Error</li> <li>• Slave Unit Verification Error</li> <li>• NX Unit Communications Timeout</li> <li>• Memory Corruption Detected</li> <li>• Errors related to EtherCAT communications settings</li> <li>• Illegal State Transition Request Received</li> <li>• Error State Transition Received</li> <li>• Synchronization Cycle Setting Error</li> <li>• NX Unit Startup Error</li> </ul>
		Single flash	<ul style="list-style-type: none"> <li>• Synchronization Interruption Error</li> <li>• Synchronization Error</li> <li>• Communications Synchronization Error</li> <li>• Restarting is in progress for the Slave Terminal</li> <li>• In parameter overwrite mode</li> </ul>
	Double flash	Process Data WDT Error	
---	 Not lit.	No error	



### Additional Information

The timing of flashing and flickering of the indicators is shown below.

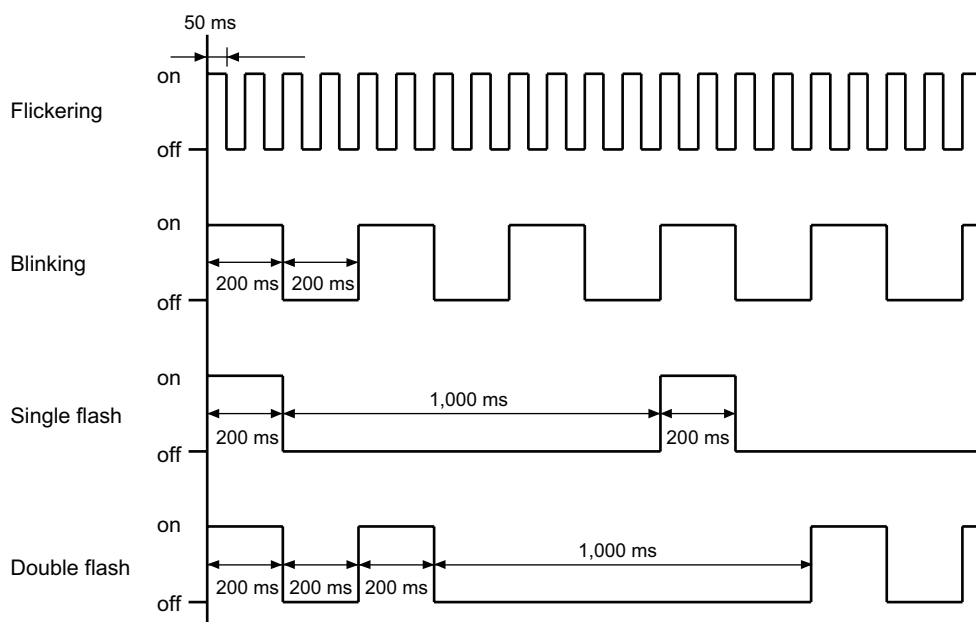

## Appearance Change of the Indicators

---

The appearance of the indicators has been changed for models released in or before September 2018 with lot numbers that represent the date of or after September 20, 2018. See below for details on the applicable models and the changes. Models that are not listed here have the appearance after the change.

- **Applicable Models**

NX-ECC201, NX-ECC0202, NX-ECC203

- **Change Details**

The shape of the light emitting part of each indicator has been changed from a square to a pentagon.

Below is an example of the TS indicator.

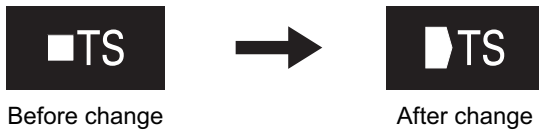

## 4-3 Hardware Switch Settings

This section describes the functions of the hardware switches (i.e., the rotary switches and the DIP switch) on the front panel of the EtherCAT Coupler Unit.

### 4-3-1 Rotary Switches

The rotary switches are used to set the node address of the EtherCAT Slave Terminal on the EtherCAT network. They set the node address as the 10s digit and 1s digit of the decimal value. The 100s digit is set on pin 4 of the DIP switch that is described below.

The setting range is from 00 to 99. (The factory setting is 00.)

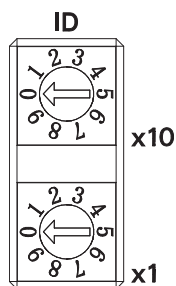

Refer to 4-3-3 *Setting the Node Address* on page 4-13 for information on setting the node address by combining the rotary switches and pin 4 of the DIP switch that is described below.



#### Precautions for Correct Use

The label above the rotary switches depends on the model, unit version, and lot number of the EtherCAT Coupler Unit as shown below.

Model	Unit version	Label
<ul style="list-style-type: none"> <li>NX-ECC201</li> <li>NX-ECC202</li> </ul>	Version 1.0 or later	<ul style="list-style-type: none"> <li>Lot number: November 14, 2018 or earlier ADR</li> <li>Lot number: November 15, 2018 or later ID</li> </ul>
NX-ECC203	Version 1.4 or earlier	ADR
	Version 1.5 or later	ID

### 4-3-2 DIP Switch

If you turn ON pin 4 on the DIP switch, 100 will be added to the node address that is set on the rotary switches.

The other pins are reserved by the system.

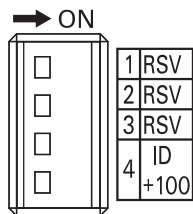

Pin	Name	Description
Pin 1	Reserved by the system.	Keep turned OFF. (The factory setting is OFF.)
Pin 2		
Pin 3		
Pin 4	Node addresses + 100	ON: The address that is set on the rotary switches is increased by 100. OFF: The address that is set on the rotary switches is not increased by 100. (The factory setting is OFF.)

Refer to 4-3-3 *Setting the Node Address* on page 4-13 for information on setting the node address by combining the rotary switches that are described above and pin 4 of the DIP switch.



#### Precautions for Correct Use

The label above the SW4 DIP switch depends on the model, unit version, and lot number of the EtherCAT Coupler Unit as shown below.

Model	Unit version	Label
<ul style="list-style-type: none"> <li>NX-ECC201</li> <li>NX-ECC202</li> </ul>	Version 1.0 or later	<ul style="list-style-type: none"> <li>Lot number: November 14, 2018 or earlier ADR+100</li> <li>Lot number: November 15, 2018 or later ID+100</li> </ul>
	Version 1.4 or earlier	ADR+100
	Version 1.5 or later	ID+100

### 4-3-3 Setting the Node Address

You must set the node address to enable the EtherCAT master to recognize the EtherCAT Slave Terminal.

There are two ways to set the node address: Switch settings and settings from the Sysmac Studio. The switch settings are used to select the method to use.

#### Setting the Node Address with Switch Settings

The following switches are used to set the node address. The setting ranges are given in the following table.

If these switches are used, the node address that is set on the switches will be valid. (The factory setting is 000.)

Switch	Node address	Node address setting	
		When the settable node address range for the built-in EtherCAT port is 1 to 512	When the settable node address range for the built-in EtherCAT port is 1 to 192
DIP switch pin 4	100s digit	001 to 199	001 to 192
Top rotary switch	10s digit		
Bottom rotary switch	1s digit		

You can set any node address that is within the setting range as long as the same node address is not set for another EtherCAT slave on the EtherCAT network.

#### Setting the Node Address from the Sysmac Studio

To set the node address from the Sysmac Studio, set the switches to 000, as shown below. This will enable setting the node address from the Sysmac Studio.

Switch	Node address	Node address setting
DIP switch pin 4	100s digit	0 (OFF)
Top rotary switch	10s digit	0
Bottom rotary switch	1s digit	0

Place the Sysmac Studio online with the NJ/NX-series CPU or the NY-series Industrial PC to set the node address from the Sysmac Studio. For the procedure to set the node address from the Sysmac Studio, refer to the user's manual for the built-in EtherCAT port on the connected CPU Unit or Industrial PC.



#### Precautions for Correct Use

- The node address that is set on the switches is read only once when the Unit power supply is turned ON or the EtherCAT Coupler Unit is restarted. Even if the node address is changed after the Unit power supply is turned ON or after the EtherCAT Coupler Unit is restarted, the new node address will not be used until the next time that power is turned ON or the EtherCAT Coupler Unit is restarted.
- An error will occur if the same node address is set for more than one slave.
- An error will occur if the node address is not within the setting range.

## 4-4 Communications Connector and Peripheral USB Port

This section provides the specifications of the communications connectors and peripheral USB port on the front panel of the EtherCAT Coupler Unit.

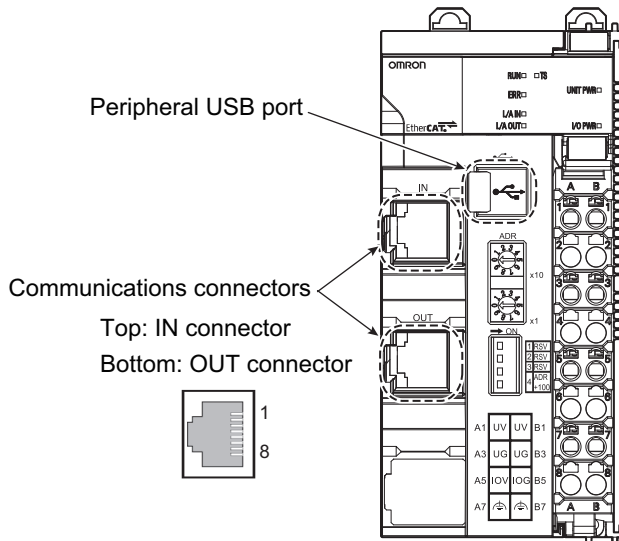

### Communications Connectors

Connect Ethernet cables to the communications connectors.

The specifications of the EtherCAT communications connectors are given below.

- Electrical specifications: Conform to IEEE 802.3 standards.
- Connector structure: RJ45 8-pin Modular Connector (Conforms to ISO 8877.)

### Peripheral USB Port

The peripheral USB port is used to connect to Support Software. You can use a USB cable to directly connect the EtherCAT Coupler Unit to the Sysmac Studio to enable setting up the EtherCAT Slave Terminal.

- Connector type: B

## 4-5 Terminal Blocks

The terminal block on the EtherCAT Coupler Unit is a removable screwless clamping terminal block that allows you to easily connect and remove the wiring.

The Unit power supply, I/O power supply, and ground wire are connected to this screwless clamping terminal block.

For details, refer to 7-2 *Connecting the Power Supply and Ground Wires* on page 7-7.

### Terminal Block Part Names and Functions

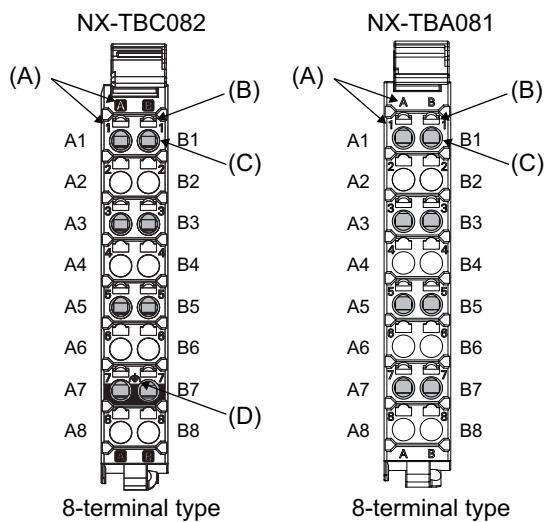

Letter	Name	Function
(A)	Terminal number indications	The terminal numbers (A1 to A8 and B1 to B8) are displayed. The terminal number indications are the same regardless of the number of terminals on the terminal block.
(B)	Release holes	Insert a flat-blade screwdriver into these holes to connect and remove the wires.
(C)	Terminal holes	The wires are inserted into these holes.
(D)	Ground terminal mark	This mark indicates the ground terminals. Only the NX-TBC082 has this mark.

Terminal blocks come in three types depending on the number of terminals that can be used. There are 8-terminal type, 12-terminal type, and 16-terminal type.

Only an 8-terminal type can be mounted to the EtherCAT Coupler Unit.

To prevent incorrect wire insertion, other Terminal blocks cannot be mounted.



#### Additional Information

On 8-terminal type of terminal blocks, the following terminals do not have terminal holes and release holes: A2, A4, A6, A8, B2, B4, B6, and B8.

## Applicable Terminal Blocks for Each Model

The current capacity of power supply terminal for each model of the EtherCAT Coupler Unit and the terminal blocks that you can use with each model are given in the following table.

Unit model number	Current capacity of Unit's power supply terminals		Terminal block			
	Unit power supply	I/O power supply	Terminal block model number	Number of terminals	Ground terminal mark	Terminal current capacity
NX-ECC202 or NX-ECC203	4 A	10 A	NX-TBC082	8	Present	10 A
NX-ECC201	4 A		NX-TBA081	8	None	4 A
			NX-TBC082	8	Present	10 A



### Precautions for Correct Use

You can mount either of the two models of terminal blocks to the NX-ECC201. However, the current capacity of the power supply terminals is 4 A. Even if you mount the NX-TBC082 Terminal Block, which has a terminal current capacity of 10 A, the rated currents of the NX-ECC201's Unit power supply and I/O power supply do not change.

To differentiate between the two models of terminal blocks, use the terminal number column indications. The terminal block with white letters on a dark background is the NX-TBC082.



### Additional Information

Refer to *A-9 Terminal Block Model Numbers* on page A-100 for the screwless clamping terminal blocks for EtherCAT Slave Terminals.

## 4-6 DIN Track Contact Plate

There is a DIN Track contact plate in the section on the back of the EtherCAT Coupler Unit that comes into contact with the DIN Track.

This plate is connected internally to the functional ground terminal on EtherCAT Coupler Unit. This means that the functional ground terminal will be electrically connected to the DIN Track.

For details, refer to 7-2-3 *Grounding the EtherCAT Slave Terminal* on page 7-8.

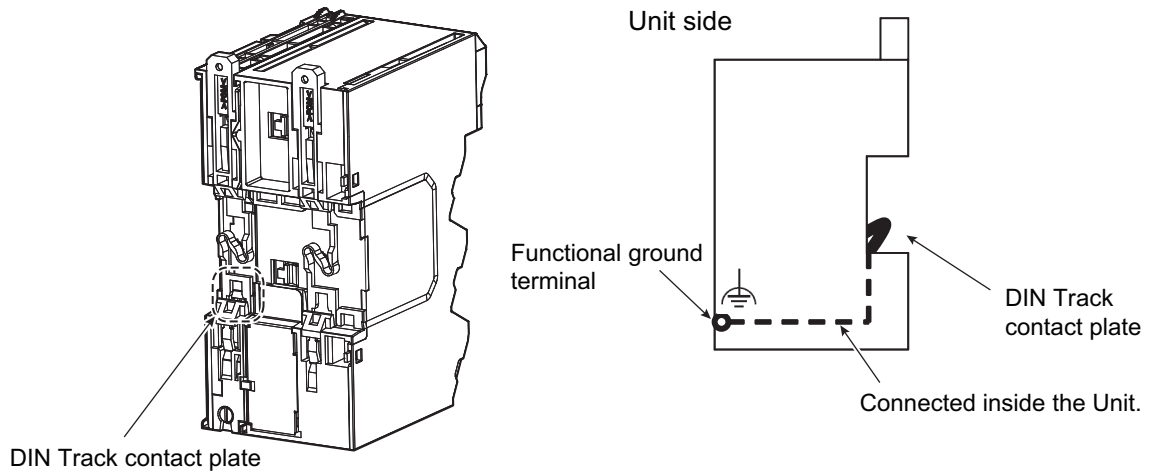



# 5

## Designing the Power Supply System

This section describes how to design the power supply system for the EtherCAT Slave Terminal.

---

<b>5-1</b>	<b>Power Supply System and Design Concepts .....</b>	<b>5-2</b>
5-1-1	Power Supply System and Types of Power Supplies .....	5-2
5-1-2	NX-series Power Supply-related Units .....	5-3
5-1-3	Design Concepts for Power Supply to the EtherCAT Slave Terminal .....	5-5
<b>5-2</b>	<b>Designing the NX Unit Power Supply System .....</b>	<b>5-6</b>
5-2-1	Procedure for Designing the NX Unit Power Supply System .....	5-6
5-2-2	Calculation Example for the NX Unit Power Supply .....	5-7
<b>5-3</b>	<b>Designing the I/O Power Supply System .....</b>	<b>5-9</b>
5-3-1	I/O Power Supply Method .....	5-9
5-3-2	Designing the I/O Power Supply from the NX Bus .....	5-10
5-3-3	Designing the I/O Power Supply from External Sources .....	5-14
5-3-4	Restrictions on Inrush Current for ON/OFF Operation .....	5-14
<b>5-4</b>	<b>Selecting External Power Supplies and Protective Devices .....</b>	<b>5-16</b>
5-4-1	Selecting the Unit Power Supply .....	5-16
5-4-2	Selecting the I/O Power Supplies .....	5-18
5-4-3	Selecting Protective Devices .....	5-20

# 5-1 Power Supply System and Design Concepts

This section describes the power supply system for an EtherCAT Slave Terminal and the design concepts.

## 5-1-1 Power Supply System and Types of Power Supplies

### Power Supply System Configuration Diagram

An example of a power supply system configuration diagram for an EtherCAT Slave Terminal is shown below.

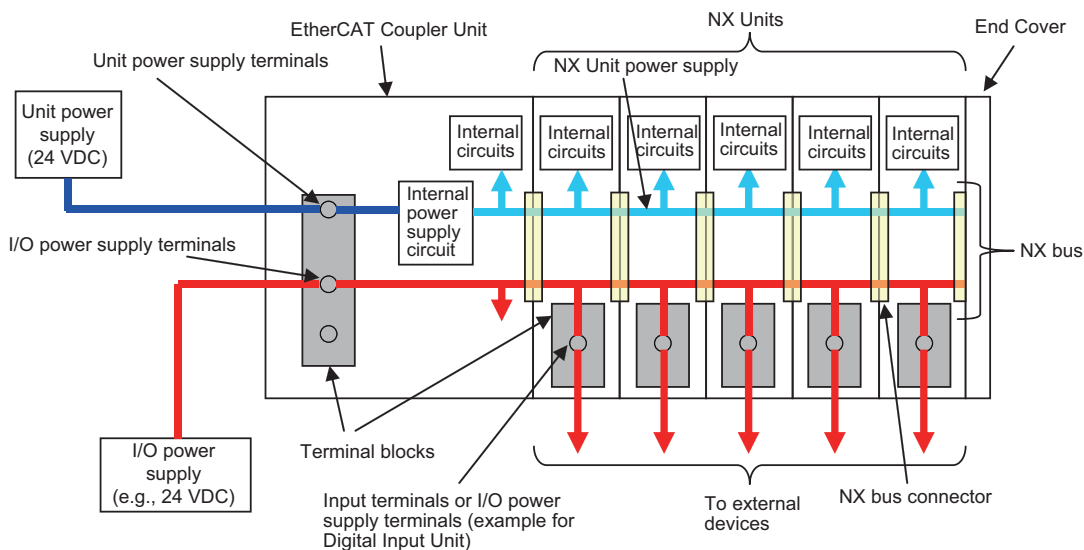

### Power Supply Types

There are the following two types of power supplies that supply power to the EtherCAT Slave Terminal.

Power supply type	Description
Unit power supply	<p>This power supply is required to generate the NX Unit power, which is necessary for the EtherCAT Slave Terminal to operate.</p> <p>This power supply is connected to the Unit power supply terminals on the EtherCAT Coupler Unit.</p> <p>The internal power supply circuit in the EtherCAT Coupler Unit generates the NX Unit power supply from the Unit power supply.</p> <p>The internal circuits of the EtherCAT Coupler Unit and of the NX Units operate on the NX Unit power supply.</p> <p>The NX Unit power is supplied to the NX Units in the Slave Terminal through the NX bus connectors.</p>

Power supply type	Description
I/O power supply	This power supply drives the internal I/O circuits of the NX Units and it is used for the connected external devices. This power supply is connected to the I/O power supply terminals on the EtherCAT Coupler Unit. The I/O power is supplied to the NX Units from the I/O power supply terminals and through the NX bus connectors.



**Precautions for Correct Use**

Always use separate power supplies for the Unit power supply and the I/O power supply. If you supply power from the same power supply, noise may cause malfunctions.

**5-1-2 NX-series Power Supply-related Units**

The EtherCAT Coupler Unit supplies the NX Unit power and I/O power to the NX Units in the Slave Terminal. The Units that are related to power supply for the NX-series other than the EtherCAT Coupler Unit are listed in the following table.

For the specifications of NX-series power supply-related Units, refer to the *NX-series System Units User's Manual (Cat. No. W523)*. For information on the most recent lineup of NX-series power supply-related Units, refer to *NX-series catalogs* or OMRON websites, or ask your OMRON representative.

Unit name	Function
Additional NX Unit Power Supply Unit	<p>This NX Unit provides NX Unit power supply. This NX Unit is used when the total power consumption of the NX Units in the Slave Terminal exceeds the NX Unit power supply capacity of the EtherCAT Coupler Unit.</p> <div style="text-align: center;"> <p>The total power consumption from the NX Unit power supply is within the NX Unit power supply capacity.      The total power consumption from the NX Unit power supply is within the NX Unit power supply capacity.</p> <p>←-----&gt;      ←-----&gt;</p> <p>NX Unit      Separated by Additional NX Unit Power Supply Unit</p> </div> <p>The diagram illustrates the power supply configuration. On the left, the EtherCAT Coupler Unit has 'Unit power supply terminals' and 'I/O power supply' terminals. A 'Unit power supply' is connected to the coupler. Blue lines show power being distributed to 'NX Unit power supply' terminals on the coupler and then to 'Internal power supply circuit' blocks within the 'NX Unit' and 'Additional NX Unit Power Supply Unit'. Red lines show 'I/O power supply' being connected to 'I/O power supply terminals' on the coupler and then to 'Internal power supply circuit' blocks within the 'Additional NX Unit Power Supply Unit'. Dashed arrows indicate that the total power consumption from the NX Unit power supply is within the capacity of both the coupler and the additional unit.</p> <p>The I/O power supply for the Additional NX Unit Power Supply Unit is connected to the NX Unit on the left through the NX bus connector.</p>

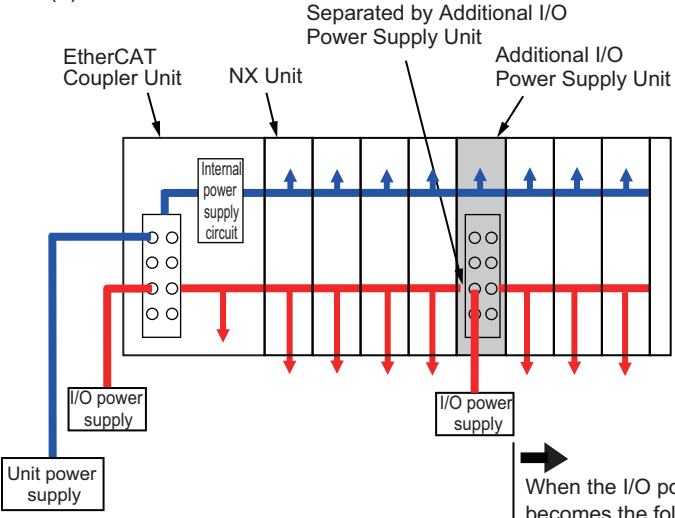
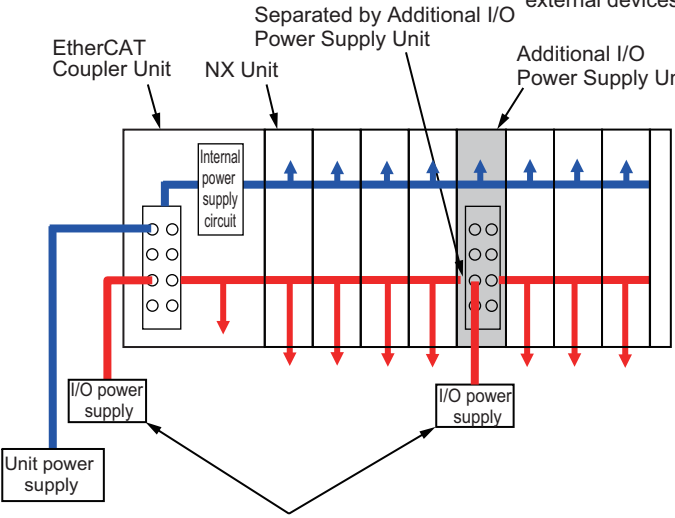
Unit name	Function
<p>Additional I/O Power Supply Unit</p>	<p>This NX Unit provides additional I/O power supply. Use this NX Unit in the following cases.</p> <p>(a) When the I/O power supply capacity is insufficient</p> <ul style="list-style-type: none"> <li>• When the total current consumption for the I/O power supply exceeds the maximum I/O power supply current of the EtherCAT Coupler Unit</li> <li>• When a voltage drop in the I/O power supply causes the voltage of the I/O power supply to go below the voltage specifications of the I/O circuits or connected external devices</li> </ul> <p>(b) Separating the I/O power supply</p> <ul style="list-style-type: none"> <li>• When connected external devices have different I/O power supply voltages</li> <li>• When separating the power supply systems</li> </ul> <p>Case (a)</p>  <p>Separated by Additional I/O Power Supply Unit</p> <p>When the I/O power supply becomes the following states for the subsequent NX Units.</p> <ul style="list-style-type: none"> <li>- When it exceeds the maximum I/O power supply current</li> <li>- When it goes below the voltage specifications of the connected external devices</li> </ul> <p>Case (b)</p>  <p>Separated by Additional I/O Power Supply Unit</p> <ul style="list-style-type: none"> <li>- When different I/O power supply voltage are used.</li> <li>- When separating the power supply systems.</li> </ul> <p>The NX Unit power supply of the Additional I/O Power Supply Unit is connected to the NX Unit on the left through the NX bus connector.</p>

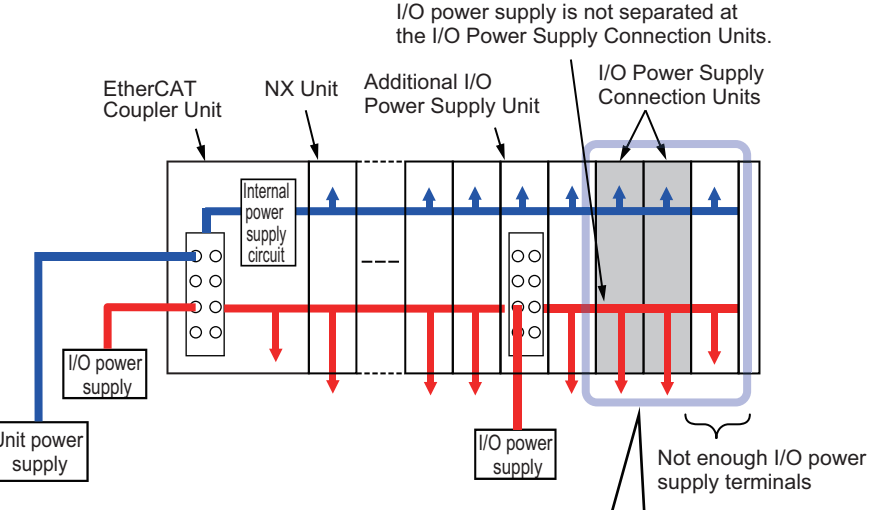
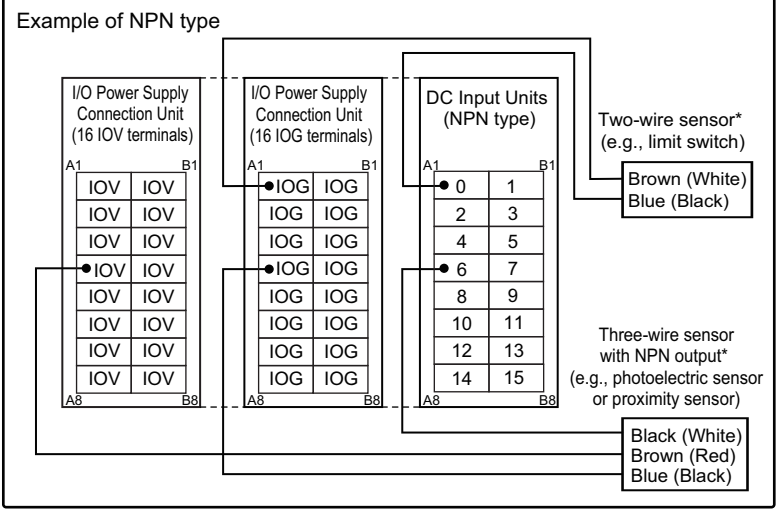
Unit name	Function
I/O Power Supply Connection Unit	<p data-bbox="571 259 1465 353">This NX Unit is used when there are not enough I/O power supply terminals for the connected external devices that are connected to NX Units such as Digital I/O Units and Analog I/O Units.</p>  <p data-bbox="587 913 810 943">Example of NPN type</p>  <p data-bbox="571 1458 1465 1547">*1. Wire colors have been changed according to revisions in the JIS standards for photoelectric and proximity sensors. The colors in parentheses are the wire colors prior to the revisions.</p>

### 5-1-3 Design Concepts for Power Supply to the EtherCAT Slave Terminal

- The following must be studied when designing the power supply system to the EtherCAT Slave Terminal.
- The NX Unit power supply and I/O power supply systems must be designed and then the design conditions for both must be confirmed.
  - The external power supplies (i.e., Unit power supply and I/O power supplies) must be selected.

## 5-2 Designing the NX Unit Power Supply System

This section describes how to design the NX Unit power supply to the EtherCAT Slave Terminal.

### 5-2-1 Procedure for Designing the NX Unit Power Supply System

The total power consumption from the NX Unit power supply must not exceed the NX Unit power supply capacity of the Unit that supplies the NX Unit power.

Use the following procedure to design the NX Unit power supply.

- 1** Calculate the total power consumption from the NX Unit power supply that is required by the NX Units that are connected to the EtherCAT Coupler Unit.
- 2** If the total power consumption from the NX Unit power supply exceeds the NX Unit power supply capacity of the EtherCAT Coupler Unit, add an Additional NX Unit Power Supply Unit to the right of an NX Unit before the capacity is exceeded.
- 3** Calculate the total power consumption from the NX Unit power supply that is required by the NX Units that are connected after the Additional NX Unit Power Supply Unit.  
If the total power consumption of those NX Units exceeds the NX Unit power supply capacity of the Additional NX Unit Power Supply Unit, add another Additional NX Unit Power Supply Unit to the right of an NX Unit before the capacity is exceeded.
- 4** Repeat step 3 until the design conditions for the NX Unit power supply are met.

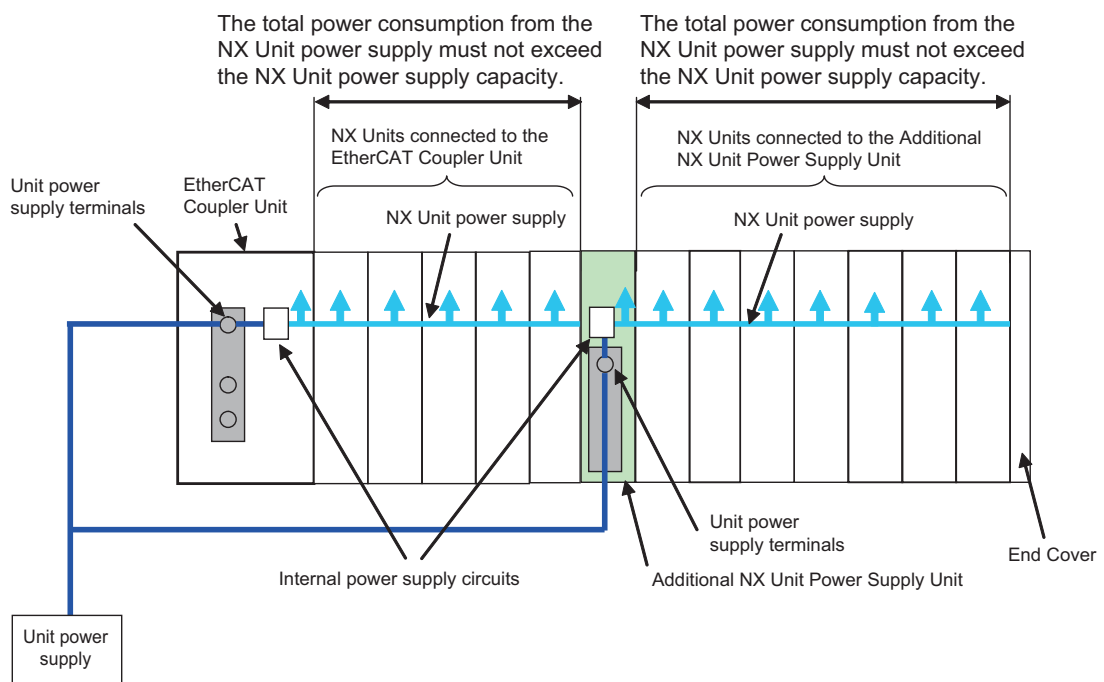

## ● NX Unit Power Supply Capacity and Restrictions

The internal power supply circuits of the EtherCAT Coupler Unit or Additional NX Unit Power Supply Unit supply the NX Unit power to the NX Units.

The NX Unit power supply capacity does not include the NX Unit power consumption of the EtherCAT Coupler Unit or Additional NX Unit Power Supply Units.

The NX Unit power supply capacity of the EtherCAT Coupler Unit is restricted by the following application conditions.

- Ambient operating temperature
- Installation orientation

Consider these conditions and determine the required NX Unit power supply capacity, and then design the NX Unit power supply system.

Refer to 3-1-2 *EtherCAT Coupler Unit Specifications* on page 3-2 for restrictions on the EtherCAT Coupler Unit.

For restrictions on the Additional NX Unit Power Supply Unit, refer to the *NX-series System Units User's Manual (Cat. No. W523)*.



### Precautions for Correct Use

- Do not exceed the NX Unit power supply capacity. If you exceed the NX Unit power supply capacity, malfunction may occur.
- Use the same Unit power supply to supply the Unit power to the entire Slave Terminal. If you supply power from different Unit power supplies, differences in electrical potential may cause unexpected currents in the NX Unit power supply, which may result in failure or malfunction.

## 5-2-2 Calculation Example for the NX Unit Power Supply

This section provides a calculation example for the NX Unit power supply.

### ● Unit Configuration Example

Name	Model	Quantity	Power consumption/ Unit
EtherCAT Coupler Unit	NX-ECC201	1	1.45 W
Digital Input Unit	NX-ID3317	5	0.5 W
Relay Output Unit	NX-OC2633	5	0.8 W

### ● Application Conditions

The ambient operating temperature is 55°C and an upright installation orientation is used.

### ● Calculating the Total Power Consumption from the NX Unit Power Supply

Calculate the total power consumption from the NX Unit power supply that is required by the NX Units that are connected to the EtherCAT Coupler Unit. The NX Unit power consumption of the EtherCAT Coupler Unit is not included in this calculation.

Total power consumption from NX Unit power supply [W] = (0.5 W × 5) + (0.8 W × 5) = 6.5 W

## ● Confirming the NX Unit Power Supply Capacity of the EtherCAT Coupler Unit

According to the graph in *Installation orientation and restrictions* on page 3-4 in *3-1-2 EtherCAT Coupler Unit Specifications* on page 3-2, the NX Unit power supply capacity is 8.5 W max.

Therefore, in this example, the total power consumption from the NX Unit power supply is 6.5 W, and the NX Unit power supply capacity is 8.5 W max., so the design conditions are met.



### Additional Information

Excess or insufficiency in the NX Unit power supply capacity can be easily checked when the Unit configuration is created on the Edit Slave Terminal Configuration Tab Page on the Sysmac Studio.

Use the following procedure to check the power supply capacity.

On the Edit Slave Terminal Configuration Tab Page on the Sysmac Studio, select the Unit to supply NX Unit power. The power that is supplied by the NX Unit power supply (i.e., the total power consumption) and the power supply capacity are displayed for the *Supply Power/Available Power* parameter.

The following example is for when the EtherCAT Coupler Unit is selected.

Item name	Value
Device name	E001
Model name	NX-ECC201
Product name	EtherCAT Coupler
Unit version	1.0
NX Unit Number	0
NX Unit Mounting Setting	---
Serial Number	---
Supply Power/Available Power	9.90 / 10.00 W
Unit width	46 mm

If the power to supply exceeds the NX Unit power supply capacity of the Unit that is selected to supply the NX Unit power, a yellow warning icon is displayed by the first NX Unit for which there is not sufficient capacity and also by all the remaining NX Units.

Item name	Value
Device name	E001
Model name	NX-ECC201
Product name	EtherCAT Coupler
Unit version	1.0
NX Unit Number	0
NX Unit Mounting Setting	---
Serial Number	---
Supply Power/Available Power	10.80 / 10.00 W
Unit width	46 mm

However, the Sysmac Studio determines excess and insufficiency in the supplied power for an NX Unit power supply capacity of 10 W max. It does not consider the power supply restrictions of the NX Unit power supply in actual application conditions and I/O power supply design conditions.

When actually designing the power supply, refer to *5-2-1 Procedure for Designing the NX Unit Power Supply System* on page 5-6 and *5-3-2 Designing the I/O Power Supply from the NX Bus* on page 5-10.

## 5-3 Designing the I/O Power Supply System

This section describes how to design the I/O power supply to the EtherCAT Slave Terminal.

### 5-3-1 I/O Power Supply Method

There is more than one method to supply the I/O power supply to the EtherCAT Slave Terminal, depending on the type and model of the NX Units.

Supply method	Description
Supply from the NX bus	Power is supplied through the NX bus connectors by connecting an I/O power supply to the I/O power supply terminals on the EtherCAT Coupler Unit or Additional I/O Power Supply Units.
Supply from external source	Power is supplied to the Units from an external source. I/O power is supplied by connecting an I/O power supply to the terminal blocks on the Units.
No supply	The I/O power supply is not needed when the NX Unit does not use it for the connected external devices, or when power for the interface is generated inside the NX Unit.

For power supply methods for specific NX Units, refer to the user's manuals for the NX Units or to *I/O power supply method* specified in the *NX-series Data Reference Manual (Cat. No. W525)*.

An example is shown below.

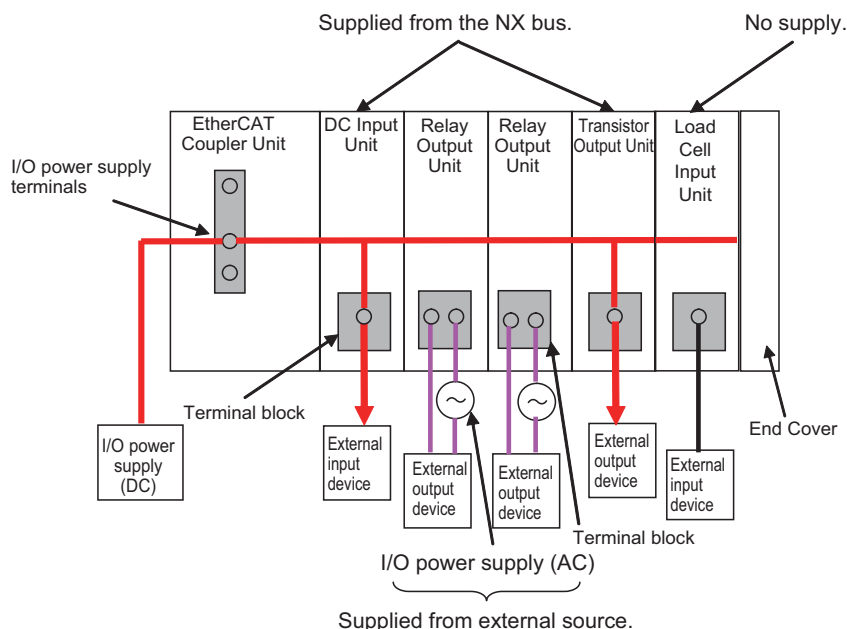

## 5-3-2 Designing the I/O Power Supply from the NX Bus

### Procedure for Designing the I/O Power Supply

Make sure that the following design conditions are met when you design the I/O power supply from the NX bus.

- The total current consumption from the I/O power supply must not exceed the maximum I/O power supply current of the Unit that supplies the I/O power.
- The voltage drop in the I/O power supply must be within the voltage specifications of the I/O circuits of the NX Units and the connected external devices.

Use the following procedure to design the I/O power supply.

- 1** Calculate the total current consumption from the I/O power supply of the EtherCAT Coupler Unit and the NX Units that are connected to the EtherCAT Coupler Unit, and calculate the voltage drop in the I/O power supply.
- 2** Add an Additional I/O Power Supply Unit in either of the following cases, (a) or (b). Add the Additional I/O Power Supply Unit to the right of the NX Unit for which both (a) and (b) do not apply.
  - a) The total current consumption for the I/O power supply exceeds the I/O power supply capacity of the EtherCAT Coupler Unit.
  - b) Voltage drop in the I/O power supply causes the voltage of the I/O power supply to go below the voltage specifications of the I/O circuits of the NX Units or the connected external devices.
- 3** Calculate the voltage drop in the I/O power supply after the Additional I/O Power Supply Unit and the total current consumption from the I/O power supply that is required by the Additional I/O Power Supply Unit and by the NX Units that are connected after the Additional I/O Power Supply Unit.

Add another Additional I/O Power Supply Unit in either of the following cases, (a) or (b). Add the Additional I/O Power Supply Unit to the right of the NX Unit for which both (a) and (b) do not apply.

  - a) The total current consumption for the I/O power supply exceeds the I/O power supply capacity of the Additional I/O Power Supply Unit.
  - b) Voltage drop in the I/O power supply causes the voltage of the I/O power supply to go below the voltage specifications of the I/O circuits of the NX Units or the connected external devices.
- 4** Repeat step 3 until the design conditions for the I/O power supply are met.

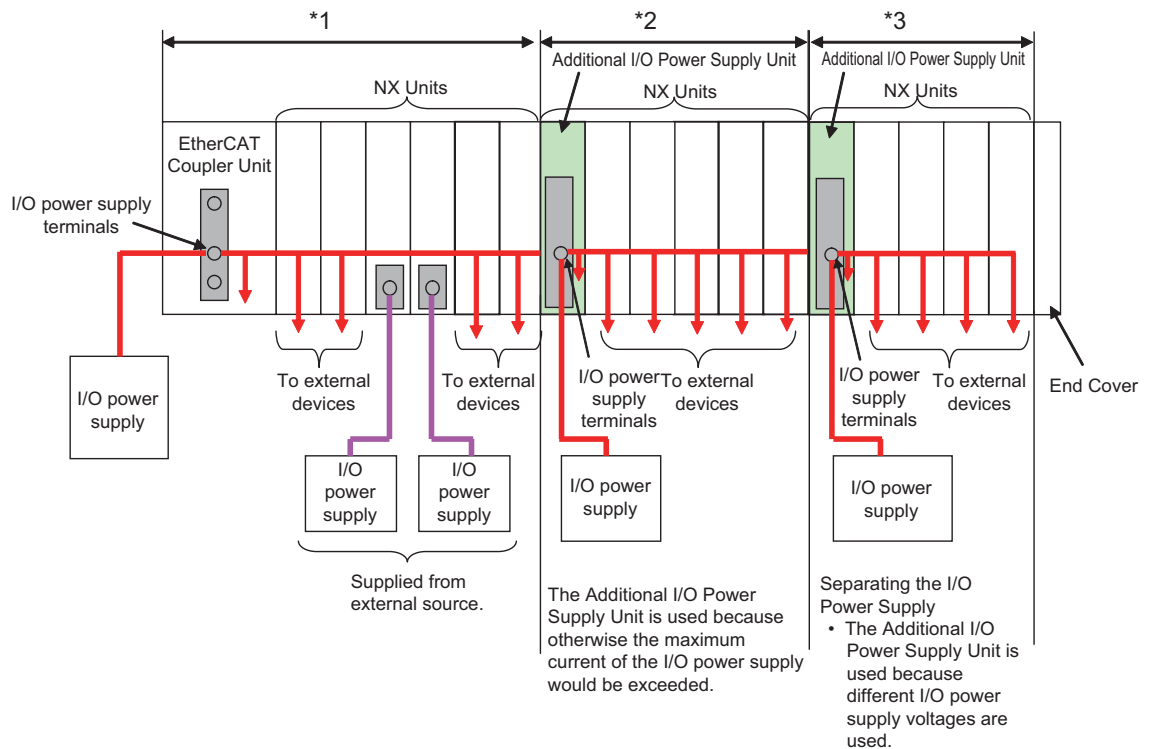

- \*1.
  - The total current consumption from the I/O power supply must not exceed the maximum current of the I/O power supply. (NX Units that are supplied power from external sources are not included in the calculation.)
  - The voltage drop in the I/O power supply must be within the voltage specifications of the I/O circuits of the NX Units and the connected external devices.
- \*2.
  - The total current consumption from the I/O power supply must not exceed the maximum current of the I/O power supply.
  - The voltage drop in the I/O power supply must be within the voltage specifications of the I/O circuits of the NX Units and the connected external devices.
- \*3.
  - The total current consumption from the I/O power supply must not exceed the maximum current of the I/O power supply.
  - The voltage drop in the I/O power supply must be within the voltage specifications of the I/O circuits of the NX Units and the connected external devices.

### ● Maximum I/O Power Supply Current

The maximum I/O power supply current is the maximum current that the I/O power supply that is connected to the EtherCAT Coupler Unit or Additional I/O Power Supply Unit can supply through the NX bus connectors to the NX Units.

For the maximum I/O power supply current of the EtherCAT Coupler Unit, refer to 3-1-2 *EtherCAT Coupler Unit Specifications* on page 3-2.

For the maximum I/O power supply current of the Additional I/O Power Supply Unit, refer to the *NX-series System Units User's Manual (Cat. No. W523)*.

## Calculating the Total Current Consumption from the I/O Power Supply

The total current consumption from the I/O power supply from the NX bus is the total of the following current consumptions.

- The current consumption from the I/O power supply that is required for the EtherCAT Coupler Unit or the Additional I/O Power Supply Unit, and for the NX Units that are connected to the EtherCAT Coupler Unit or Additional I/O Power Supply Unit
- The current consumption between the NX Units and the connected external devices

Current consumption item	Description
Current consumption from I/O power supply	This is the current that is consumed by the internal circuits that operate on the I/O power supply. Specific values are given in the user's manuals for individual Units.
Current consumption between the NX Units and the connected external devices	This is the current that is consumed between the NX Units and the connected external devices. For example, this is the current consumed by a Digital Input Unit to supply power to photoelectric sensors or to turn ON the input circuits in the Digital Input Unit. The current consumption depends on the type of I/O circuit in the NX Unit, the number of I/O points that are used, and the current consumption of the connected external device. It must be calculated for each NX Unit.

### ● Calculation Examples

Examples of calculating the current consumption from the I/O power supply are given below for a Digital Input Unit and Digital Output Unit.

Current consumption of Digital Input Unit	=	Current consumption from I/O power supply + (Input current × Number of inputs used) + Total current consumption of connected input devices
---	---	--

Current consumption of Digital Output Unit	=	Current consumption from I/O power supply + Total load current of connected loads + Total current consumption of connected output devices
--	---	---

For the methods to calculate the I/O power supply current consumption for NX Units, refer to *Calculating the Total Current Consumption from I/O Power Supply* or *Connecting the Power Supply* in the user's manuals for the NX Units.

## Calculating the Voltage Drop in the I/O Power Supply

Voltage drop occurs in the EtherCAT Slave Terminal due to the contact resistance at the points where Units are connected to each other. Design the I/O power supply system to maintain the voltage specifications of the NX Unit I/O circuits and connected external devices even if the voltage of the I/O power supply drops.

As shown in the following table, the voltage drop per Unit depends on the total current consumption from the I/O power supply.

However, the total current consumption from the I/O power supply must not exceed the maximum I/O power supply current of the Unit that supplies the I/O power.

Total current consumption from the I/O power supply	Voltage drop per Unit
10 A	0.20 V
8 A	0.16 V
6 A	0.12 V
4 A	0.08 V
3 A	0.06 V
2 A	0.04 V
1 A	0.02 V

Here, the following Unit configuration example is used to show how to calculate the I/O power that is supplied by the EtherCAT Coupler Unit. The same method can be used to calculate the I/O power supply from an Additional I/O Power Supply Unit.

Example:

- Total current consumption from the Units that are supplied I/O power from the EtherCAT Coupler Unit (total for (1) to (7) = 4 A)
- Units that are supplied I/O power from the Additional I/O Power Supply Unit

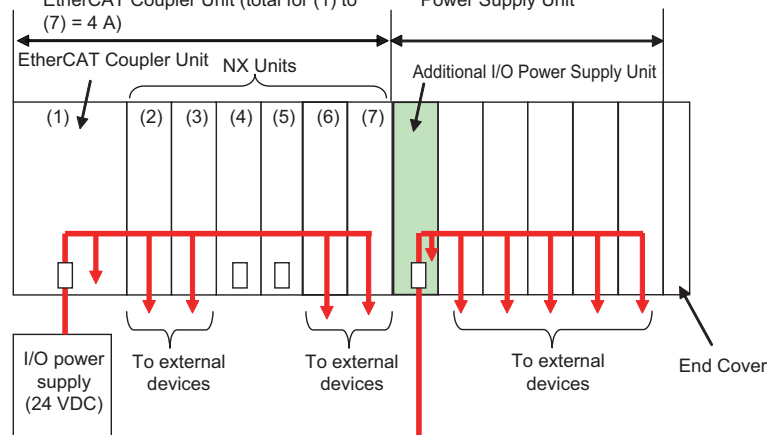

Power Consumption of Individual Units  
 (1): 0 A\*1 (Supplied from the NX bus.)  
 (2) and (3): 1.5 A each (Supplied from the NX bus.)  
 (4) and (5): 0 A (Supplied from external source.)  
 (6) and (7): 0.5 A each (Supplied from the NX bus.)

\*1. The current consumption of the EtherCAT Coupler Unit is not actually 0 A. However, a value of 0 A is used in this calculation example.

In actual calculations, use the current consumption from the I/O power supply that is given elsewhere in this manual.

### ● Outline

Find the I/O power supply voltage of the NX Unit that is the farthest from the EtherCAT Coupler Unit. In this example, the I/O power supply voltage of Unit (7) is found.

### ● Conditions

Assume that an I/O power supply voltage of 24.00 VDC is supplied to the I/O power supply terminals on the EtherCAT Coupler Unit.

### ● Procedure

- 1 Use the following formula to calculate the total current consumption from the I/O power supply.

Total current consumption from the I/O power supply	=	(1) + (2) + (3) + (4) + (5) + (6) + (7)
	=	0 A + 1.5 A + 1.5 A + 0 A + 0 A + 0.5 A + 0.5 A
	=	4 A

- 2 Find the I/O power supply voltage and make sure that it is within the voltage specifications of the I/O circuits of the NX Units and the connected external devices.

I/O power supply voltage at (7)	=	I/O power supply voltage on I/O power supply terminals – (Voltage drop per Unit × Number of Units passed through)
	=	24.00 V – 0.08 V × (7 – 1 Units)
	=	23.52 V

## Design to Separate the I/O Power Supply

If the I/O power supply voltages of the connected external devices are different, connect an Additional I/O Power Supply Unit at the point where the I/O power supply voltage changes and then perform similar calculations to design a system that meets the power supply conditions. The same method is used to separate the power supply systems. Connect an Additional I/O Power Supply Unit at the point where the power supply systems are to be separated and then perform similar calculations to design the overall system to meet the power supply conditions.

### 5-3-3 Designing the I/O Power Supply from External Sources

Unlike supplying power from the NX bus, there is no specific design method for supplying I/O power from external sources.

Calculate the total current consumption from the I/O power supply for the NX Units to be supplied power from an external source.

For the total current consumption from the I/O power supply, refer to *Calculating the Total Current Consumption from I/O Power Supply* or *Connecting the Power Supply* in the user's manuals of the NX Units.

### 5-3-4 Restrictions on Inrush Current for ON/OFF Operation

This section describes the restrictions on inrush current from the I/O power supply that occurs when connected external devices turn ON and OFF.

## Inrush Current Restrictions

If inrush current to the I/O power supply occurs when a connected external device turns ON or OFF, do not allow the effective value of the I/O power supply current to exceed the following rated values when the inrush current is added to the current consumption from the I/O power supply.

- Maximum I/O power supply current
- Current capacity of power supply terminals for the I/O power supply

Do not allow the inrush current to exceed the values given in the following table.

Unit	Model	Peak value	Pulse width
EtherCAT Coupler Unit	NX-ECC203	50 A	1 s
	NX-ECC202		
	NX-ECC201	20 A	1 s

## Calculating the Effective Value of the I/O Power Supply Current

The formula to calculate the effective value of the I/O power supply current,  $I_{rms}$ , is given below.

$$I_{rms} = \sqrt{I_p^2 \times D + I_a^2 \times (1 - D)}$$

$$(D = \tau / T)$$

- $I_p$ : Peak inrush current (A)
- $I_{rms}$ : Effective value of I/O power supply current (A)
- $I_a$ : Total current consumption from the I/O power supply (A)
- $D$ : Inrush current duty
- $\tau$ : Inrush current pulse width (s)
- $T$ : Inrush current period (s)

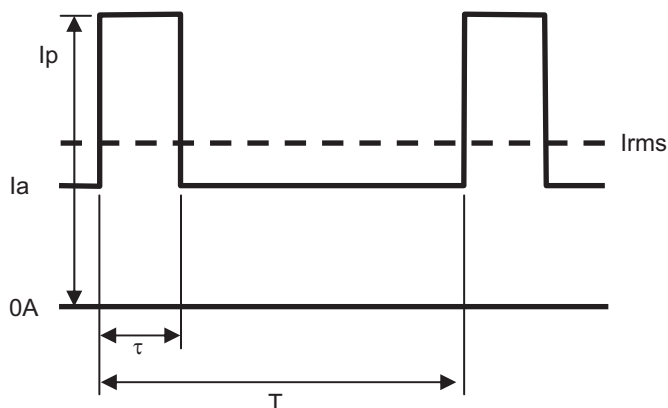

## 5-4 Selecting External Power Supplies and Protective Devices

This section describes how to select the external power supplies and protective devices for the EtherCAT Slave Terminal, i.e., the Unit power supply and the I/O power supplies.

### 5-4-1 Selecting the Unit Power Supply

This section describes how to select the Unit power supply for the EtherCAT Slave Terminal.

#### Recommended Power Supplies

Use an SELV power supply that meets the following conditions for the Unit power supply.

- Has overcurrent protection.
- Has double or reinforced insulation between the input and output.
- Has an output voltage of 24 VDC (20.4 to 28.8 VDC).

Recommended Power Supplies: S8JX Series (manufactured by OMRON)

#### Calculating the Required Power Supply Capacity of the Unit Power Supply

##### ● Formula

This section describes how to calculate the required capacity of the Unit power supply for the EtherCAT Slave Terminal.

Required capacity of Unit power supply for the EtherCAT Slave Terminal	=	Total of required Unit power supply capacity for each block
--	---	---

Use the following formula to calculate the required Unit power supply capacity for each block in the EtherCAT Slave Terminal.

$$\text{Required Unit power supply capacity of each block} = (A + B)/C$$

(A)	NX Unit power consumption of the Unit that supplies the NX Unit power
(B)	Total power consumption from the NX Unit power supply that is required by the NX Units that are connected to the Unit that supplies NX Unit power
(C)	NX Unit power supply efficiency of the Unit that supplies the NX Unit power

## ● Blocks

A block consists of the Unit that supplies the NX Unit power and the range of Units to which that Unit supplies the NX Unit power. For example, in the configuration in the following figure there are two blocks in the EtherCAT Slave Terminal: the block with the EtherCAT Coupler Unit and the block with the Additional NX Unit Power Supply Unit.

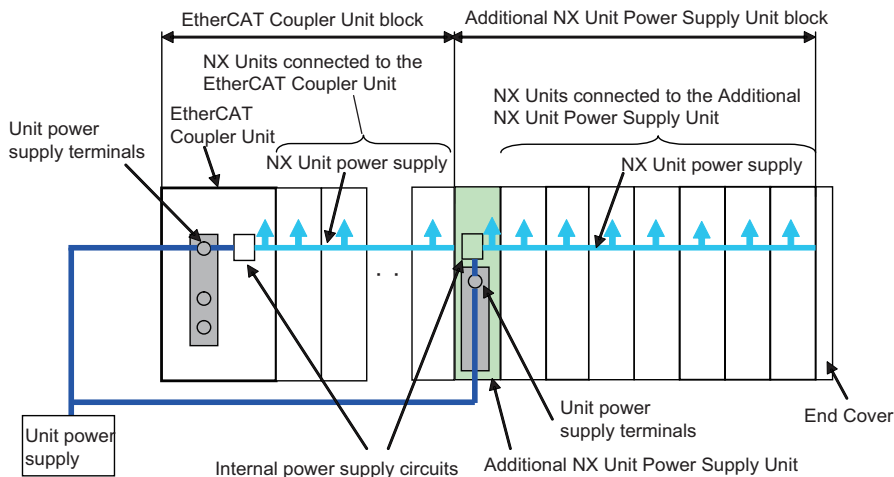

The total of the required Unit power supply capacity for these two blocks is the required power supply capacity of the Unit power supply for the EtherCAT Slave Terminal.



### Precautions for Correct Use

Use the same Unit power supply to supply the Unit power to the entire Slave Terminal. If you supply power from different Unit power supplies, differences in electrical potential may cause unexpected currents in the NX Unit power supply, which may result in failure or malfunction.

## ● Calculation Example

This section provides a calculation example for the configuration example that is given in 5-2-2 *Calculation Example for the NX Unit Power Supply* on page 5-7.

Name	Model	Quantity	Power consumption/Unit
EtherCAT Coupler Unit	NX-ECC201	1	1.45 W
Digital Input Unit	NX-ID3317	5	0.5 W
Relay Output Unit	NX-OC2633	5	0.8 W

- The NX Unit power supply efficiency of the EtherCAT Coupler Unit is 70%.

In this configuration example, there is only one block, the EtherCAT Coupler Unit block.

Required power supply capacity of Unit power supply to EtherCAT Slave Terminal

$$\begin{aligned}
 &= \text{Required Unit power supply capacity of EtherCAT Coupler Unit block} \\
 &= (\text{Power consumption from NX Unit power supply of EtherCAT Coupler Unit} + \text{Total power consumption from NX Unit power supply of NX Units connected to EtherCAT Coupler Unit}) / \text{NX Unit power supply efficiency of EtherCAT Coupler Unit} \\
 &= (1.45 \text{ W} + (0.5 \text{ W} \times 5) + (0.8 \text{ W} \times 5)) / 0.7 \\
 &= \text{Approx. } 11.4 \text{ W}
 \end{aligned}$$



### Precautions for Correct Use

---

Consider the inrush current when the power supply is turned ON and select a Unit power supply with sufficient extra capacity. The inrush current when power is turned ON may prevent the Unit power supply from operating correctly.

---

## 5-4-2 Selecting the I/O Power Supplies

This section describes how to select the I/O power supplies for the EtherCAT Slave Terminal.

### Recommended Power Supplies

---

Use an SELV power supply that meets the following conditions for the I/O power supply.

- Has overcurrent protection.
- Has double or reinforced insulation between the input and output.
- Has an output voltage of 5 to 24 VDC (4.5 to 28.8 VDC)\*1.

\*1. Use an output voltage that is appropriate for the I/O circuits of the NX Units and the connected external devices.

Recommended Power Supplies: S8JX Series (manufactured by OMRON)

### Calculating the Required Power Supply Capacity of the I/O Power Supply

---

Use the calculation method that is described in *5-3 Designing the I/O Power Supply System* on page 5-9 and calculate the total current consumption from the I/O power supply and the required power supply capacity of the I/O power supply.

Unlike the Unit power supply, it is not necessary to use only one I/O power supply to supply power to the entire Slave Terminal.



### Precautions for Correct Use

---

Consider the inrush current when the power supply is turned ON and select an I/O power supply with sufficient extra capacity. The inrush current when power is turned ON may prevent the I/O power supply from operating correctly.

---

An example of calculating the required power supply capacity of the I/O power supply is given below.

- a. Configuration and Conditions

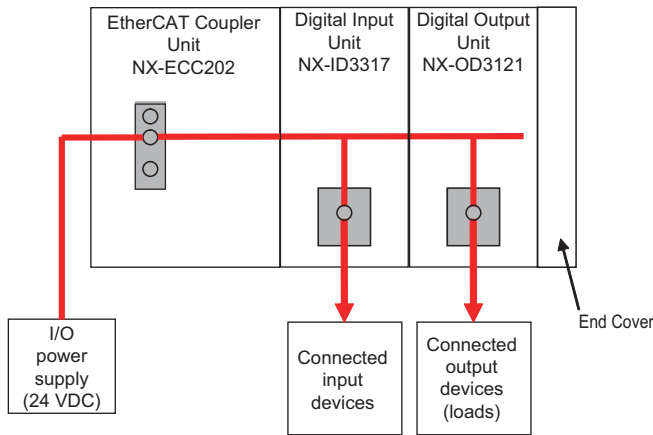

Item		Condition
I/O power supply voltage		24 VDC
Inputs	Number of inputs used (that turn ON simultaneously)	4 points
	Current consumption of connected input devices	50 mA/point
Outputs	Number of outputs (that turn ON simultaneously)	4 points
	Load current of connected loads	125 mA/point
	Current consumption of connected output devices	50 mA/point

I/O power is supplied to the NX-ID3317 and NX-OD3121 from the NX bus.

b. Unit Specifications

Model	Current consumption from I/O power supply	Input current
NX-ECC202	10 mA	---
NX-ID3317	0 mA	6 mA/point
NX-OD3121	10 mA	---

c. Calculations

The current consumption from the I/O power supply for each Unit is calculated as follows.

NX-ECC202 Current Consumption	= (Current consumption from I/O power supply)
	= 10 mA

NX-ID3317 Current Consumption	= (Current consumption from I/O power supply) + (Input current × Number of inputs used)
	+ (Total current consumption of connected input devices)
	= 0 mA + (6 mA × 4 points) + (50 mA × 4 points)
	= 224 mA

NX-OD3121 Current Consumption	= (Current consumption from I/O power supply) + (Total load current of connected loads)
	+ (Total current consumption of connected output devices)
	= 10 mA + (125 mA × 4 points) + (50 mA × 4 points)
	= 710 mA

The required power supply capacity for the I/O power supply is calculated as follows.

Power supply capacity of I/O power supply	= (Current consumed by NX-ECC202) + (Current consumed by NX-ID3317)
	+ (Current consumed by NX-OD3121)
	= 10 mA + 224 mA + 710 mA
	= 944 mA

### 5-4-3 Selecting Protective Devices

This section describes how to select protective devices (e.g., breakers and fuses) to protect against short circuits and overcurrents in external circuits.

Overcurrent is the current that flows when an excessive load is connected and one of the following ratings is exceeded.

- For the Unit power supply, the rating of the NX Unit power supply capacity or of the current capacity of the power supply terminals
- For the I/O power supply, the rating of the maximum I/O power supply current or of the current capacity of the power supply terminals

For the above ratings for the EtherCAT Coupler Unit, refer to 3-1-2 *EtherCAT Coupler Unit Specifications* on page 3-2. For the ratings of NX-series power supply-related Units, refer to the *NX-series System Units User's Manual (Cat. No. W523)*.

## Selecting Protective Devices

Consider the following items when you select protective devices.

- Protective device specifications (breaking/fusing, detection characteristics, steady current value, etc.)
- Inrush current when power is turned ON
- Inrush current when connected external devices turn ON and OFF\*1

\*1. Refer to 5-3-4 *Restrictions on Inrush Current for ON/OFF Operation* on page 5-14 for information on the in-rush current when connected external devices are turned ON and OFF.

For the breaking/fusing time, use protective devices that meet the conditions in the following table.

#### ● For Unit Power Supply

Current	Breaking/fusing time
6 A	1 min max.
12 A	15 s max.
21 A	5 s max.
30 A	2.5 s max.

#### ● For I/O Power Supply

The following values apply for a Unit which has 10 A of current capacity of the power supply terminals.

Current	Breaking/fusing time
14 A	1 min max.
28 A	9 s max.
56 A	1.5 s max.

Current	Breaking/fusing time
70 A	0.8 s max.

The following values apply for a Unit which has 4 A of current capacity of the power supply terminals.

Current	Breaking/fusing time
6 A	1 min max.
12 A	15 s max.
21 A	5 s max.
30 A	2.5 s max.

## Installation Locations for Protective Devices

Install protective devices for the Unit power supply and I/O power supply in the locations that are shown in the following figure.

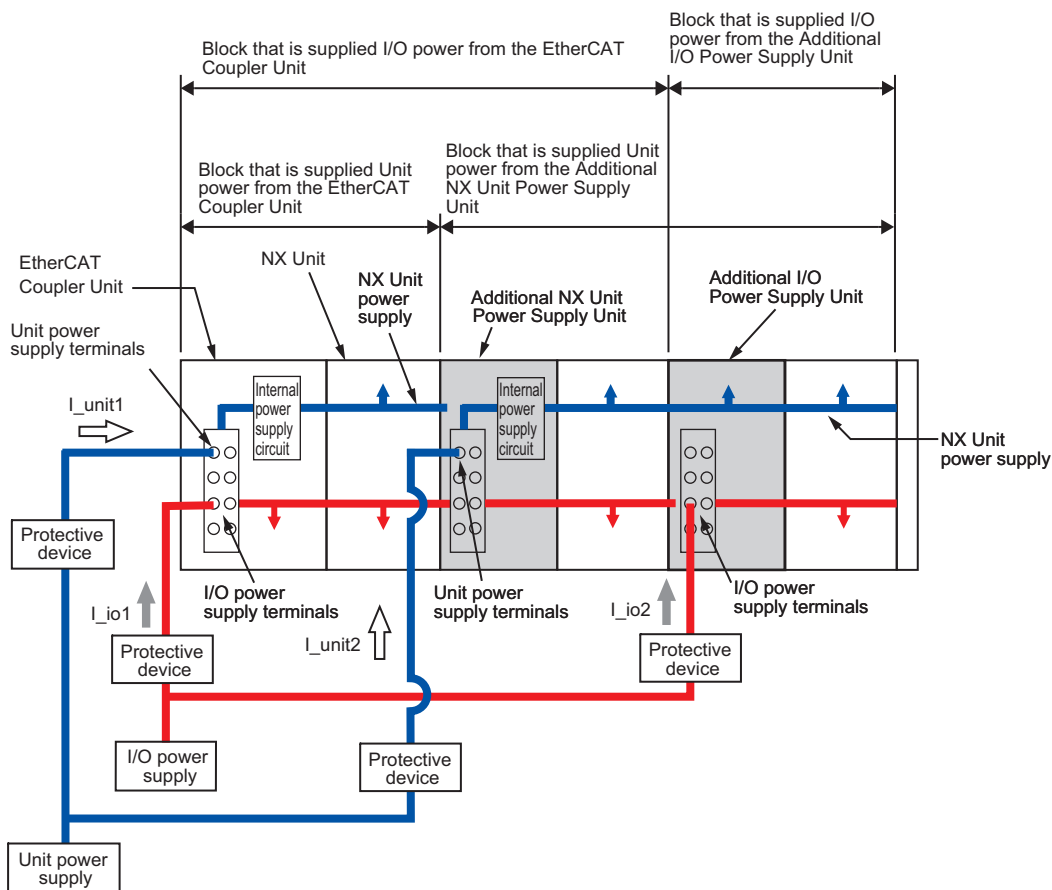

However, fewer protective devices may be required when the current consumption of each block does not exceed the rated current.

An example of this is provided below.

- Using Unwired Unit Power Supply Terminals

In this example, the current consumption from each power supply is as follows:

Current consumption from Unit power supply:  $I_{unit1} + I_{unit2} \leq \text{Lowest rated current}$

Current consumption from I/O power supply:  $I_{io1} + I_{io2} \geq \text{Lowest rated current}^{*1}$

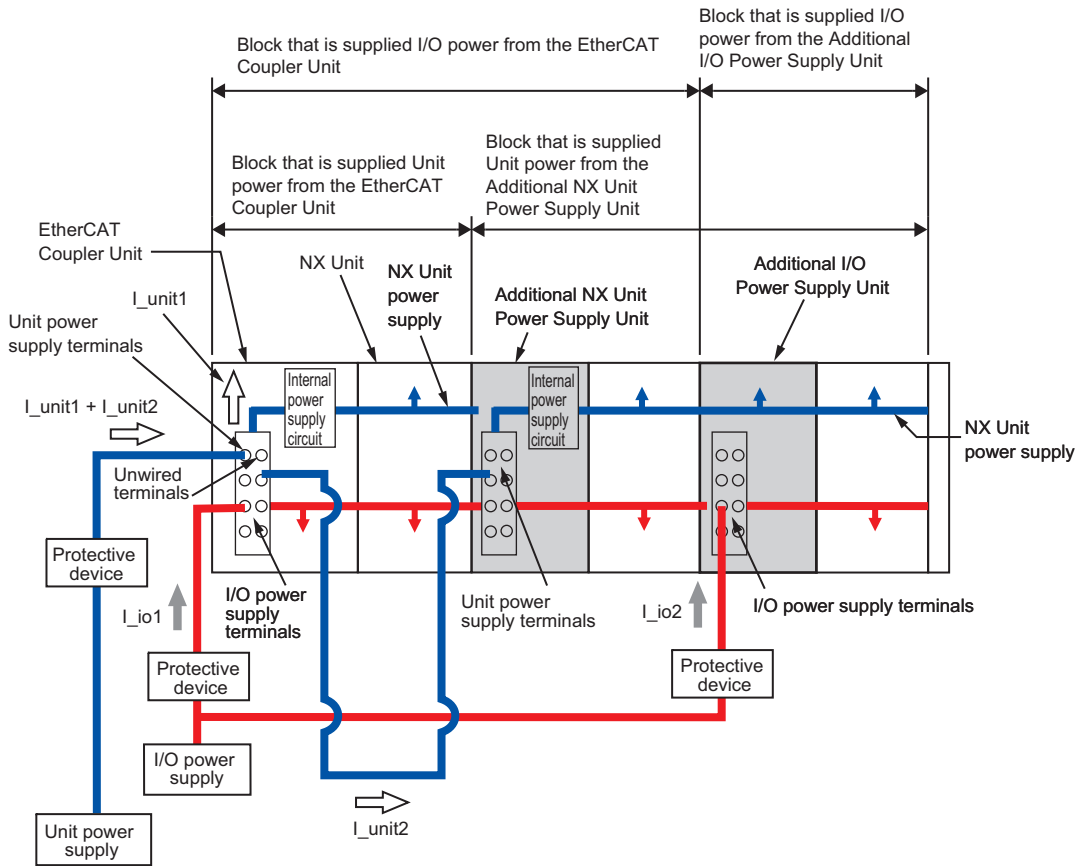

\*1. This is the lowest rated current of all of the Units that supply I/O power and are connected to protective devices. For example, if terminals with both a 10-A and 4-A capacities are connected, the value is 4 A.

- When Total Current Consumption for All Blocks Does Not Exceed the Rated Current  
 In this example, the current consumption from each power supply is as follows:  
 Current consumption from Unit power supply:  $I_{unit1} + I_{unit2} \leq \text{Lowest rated current}$   
 Current consumption from I/O power supply:  $I_{io1} + I_{io2} \leq \text{Lowest rated current}^{*1}$

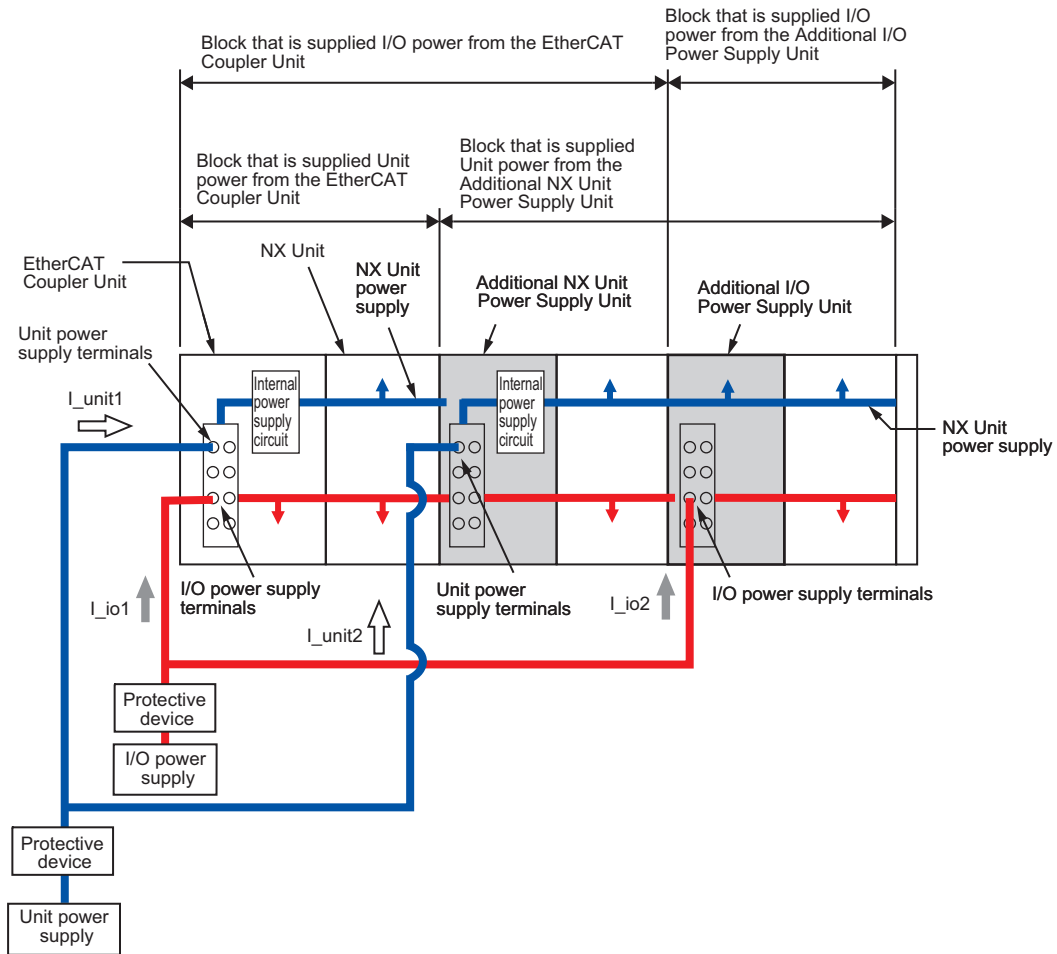

\*1. This is the lowest rated current of all of the Units that supply I/O power and are connected to protective devices. For example, if terminals with both a 10-A and 4-A capacities are connected, the value is 4 A.





# Installation

This section describes how to install the EtherCAT Slave Terminal.

---

<b>6-1</b>	<b>Installing Units.....</b>	<b>6-2</b>
6-1-1	Installation Precautions .....	6-2
6-1-2	Preparations for Installation.....	6-6
6-1-3	Installation Orientation.....	6-8
6-1-4	Installing the EtherCAT Coupler Unit.....	6-9
6-1-5	Installing and Connecting NX Units.....	6-11
6-1-6	Mounting the End Cover.....	6-14
6-1-7	Mounting the End Plates .....	6-16
6-1-8	Attaching Markers .....	6-18
6-1-9	Removing Units .....	6-19
6-1-10	Assembled Appearance and Dimensions .....	6-20
<b>6-2</b>	<b>Control Panel Installation .....</b>	<b>6-24</b>
6-2-1	Temperature .....	6-24
6-2-2	Humidity .....	6-25
6-2-3	Vibration and Shock .....	6-26
6-2-4	Atmosphere .....	6-26
6-2-5	Electrical Environment.....	6-26
6-2-6	Grounding.....	6-31

# 6-1 Installing Units

---

This section describes how to mount Units to an EtherCAT Slave Terminal.

## 6-1-1 Installation Precautions

To increase the reliability of the EtherCAT Slave Terminal and take complete advantage of its functionality, observe the following precautions.

### Installation Location

---

Do not install the EtherCAT Slave Terminal in the following locations.

- Locations subject to ambient temperatures outside the range of 0 to 55°C
- Locations subject to condensation as the result of severe changes in temperature
- Locations subject to a relative humidity outside the range of 10% to 95%
- Locations subject to corrosive or flammable gases
- Locations subject to excessive dust, salt, and metal powder
- Locations subject to shock or vibration
- Locations subject to direct sunlight
- Locations subject to splashing of water, oils, or chemicals

Take appropriate and sufficient countermeasures when installing the EtherCAT Slave Terminal in the following locations.

- Locations subject to static electricity or other forms of noise
- Locations subject to strong electromagnetic fields
- Locations subject to possible exposure to radioactivity
- Locations close to power lines

### Installation in Cabinets or Control Panels

---

Consider the ambient temperature, accessibility for operation, accessibility for maintenance, noise immunity, and installation orientation when you install the EtherCAT Slave Terminal in a cabinet or control panel.

#### ● Temperature Control

The ambient operating temperature of the EtherCAT Slave Terminal must be between 0 and 55°C. When necessary, take the following steps to maintain the proper temperature.

- Provide enough space for good air flow.
- Do not install the EtherCAT Slave Terminal directly above equipment that generates a large amount of heat such as heaters, transformers, or high-capacity resistors.
- If the ambient temperature exceeds 55°C, install a cooling fan or air conditioner.

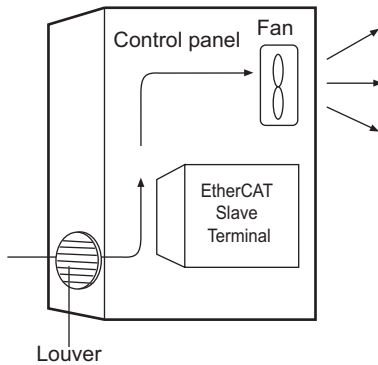

### ● Accessibility for Operation and Maintenance

- To ensure safe access for operation and maintenance, separate the EtherCAT Slave Terminal as much as possible from high-voltage equipment and power machinery.
- It will be easy to operate the EtherCAT Slave Terminal if it is mounted at a height of 1.0 to 1.6 m above the floor.

### ● Improving Noise Immunity

- Do not mount the EtherCAT Slave Terminal in a cabinet or control panel containing high-voltage equipment.
- Install the EtherCAT Slave Terminal at least 200 mm away from power lines.

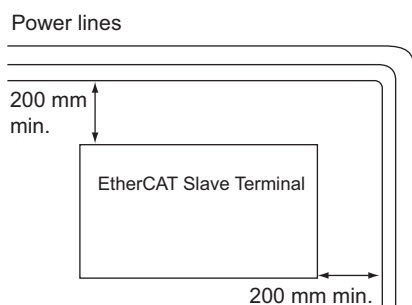

- Ground the mounting plate between the EtherCAT Slave Terminal and the mounting surface.

### ● Installation Orientation

Refer to 6-1-3 *Installation Orientation* on page 6-8.

## Installation Method in Control Panels

Mount the EtherCAT Slave Terminal on DIN Track if you install it in a cabinet or control panel. Consider the width of wiring ducts, wiring, ventilation, and Unit replacement when determining the space between EtherCAT Slave Terminals.



### Additional Information

The EtherCAT Slave Terminal must be mounted on DIN Track.  
It cannot be mounted with screws.

### ● Wiring Ducts

Whenever possible, route I/O wiring through wiring ducts.

Install mounting bases so that it is easy to wire the I/O Units through ducts. It is handy to have the ducts at the same height as the EtherCAT Slave Terminal.

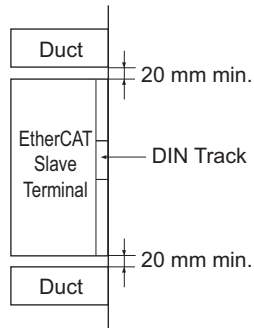

### ● Wiring Duct Example

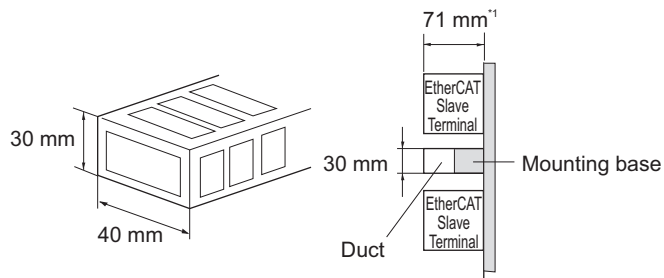

\*1. The height of the DIN Track is not considered in this figure.

## ● Routing Wiring Ducts

Install the wiring ducts at least 20 mm away from the tops of the devices and any other objects (e.g., top of the panel, other wiring ducts, structural supports, and components) to provide enough space for air circulation and replacement of Units.

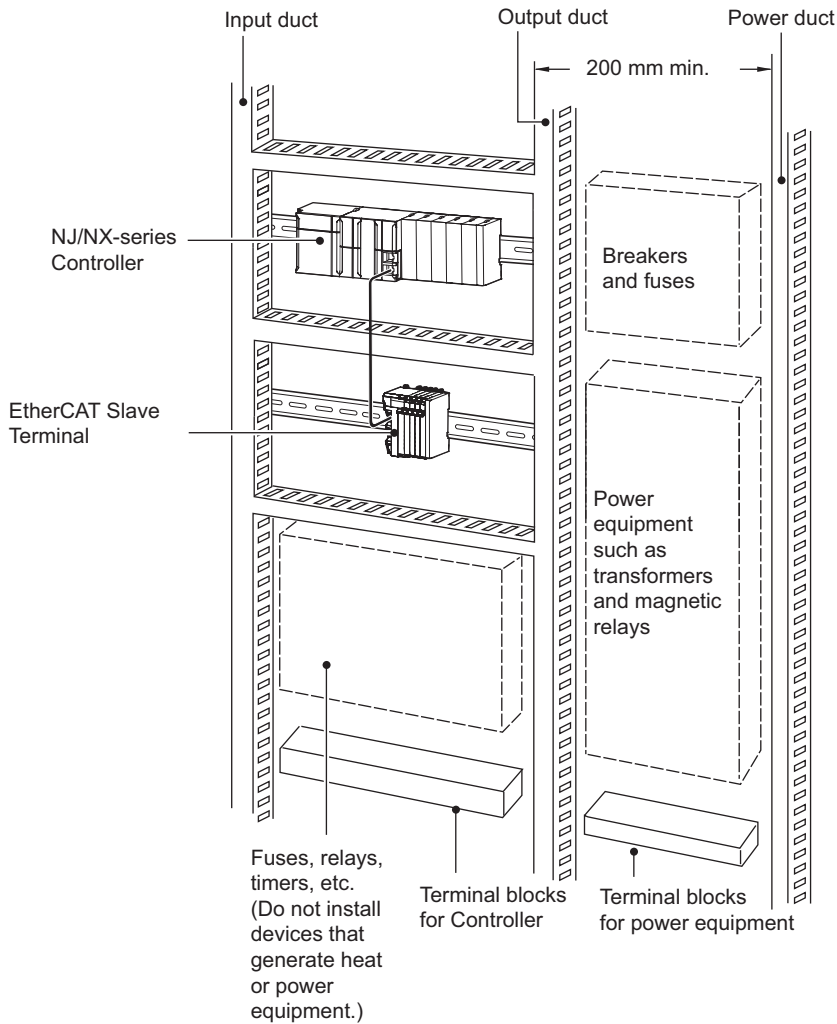

## 6-1-2 Preparations for Installation

You must install the EtherCAT Coupler Unit and NX Units on a DIN Track.

The following products are recommended.

Name	Model	Manufacturer	Remarks
35-mm DIN Track	PFP-50N	OMRON Corporation	<ul style="list-style-type: none"> <li>Length: 50 cm</li> <li>Material: Aluminum</li> <li>Surface treatment: Insulated</li> </ul>
	PFP-100N	OMRON Corporation	<ul style="list-style-type: none"> <li>Length: 100 cm</li> <li>Material: Aluminum</li> <li>Surface treatment: Insulated</li> </ul>
	NS35/7,5PERF	Phoenix Contact	<ul style="list-style-type: none"> <li>Length: 75.5, 95.5, 115.5, or 200 cm</li> <li>Material: Steel</li> <li>Surface treatment: Conductive</li> </ul>
	NS35/15PERF	Phoenix Contact	<ul style="list-style-type: none"> <li>Length: 75.5, 95.5, 115.5, or 200 cm</li> <li>Material: Steel</li> <li>Surface treatment: Conductive</li> </ul>
End Plate	PFP-M	OMRON Corporation	Two End Plates are required for each EtherCAT Slave Terminal.
	CLIPFIX 35	Phoenix Contact	Two End Plates are required for each EtherCAT Slave Terminal.

Not all of the combinations of the DIN Tracks and End Plates listed above are possible.

Confirm applicability of the combinations in the following table.

DIN Track model	PFP-M (OMRON)	CLIPFIX 35 (Phoenix Contact)
PFP-50N	Possible.	Possible.
PFP-100N	Possible.	Possible.
NS35/7,5PERF	Possible.	Possible.
NS35/15PERF	Not possible.	Possible.

Also, use screws and washers of the following sizes to fix the DIN Tracks.

(a): Dimensions from the screw head to the fastening surface

DIN Track model	Applicable screw size	(a) <sup>*1</sup>
PFP-50N	M4	4.9 mm max. (4.1 mm max.)
NS35/7,5PERF	M6	5.4 mm max. (4.6 mm max.)
NS35/15PERF	M6	10 mm max.

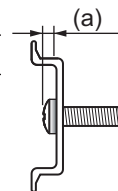

\*1. Dimensions in parentheses are for Communications Coupler Units with lot numbers through December 2014 or for NX Units with 12-mm widths with lot numbers through December 2014.

If you use any DIN Track other than those listed in the table above, refer to the dimensions shown in 6-1-10 *Assembled Appearance and Dimensions* on page 6-20 and use proper screws and washers.

● **DIN Tracks**

PFP-100N/50N DIN Track

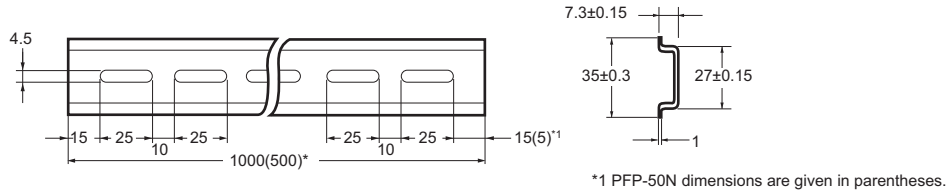

NS 35/7,5 PERF

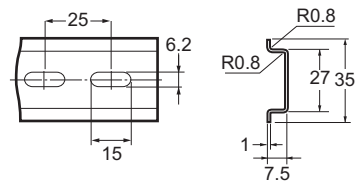

NS 35/15 PERF

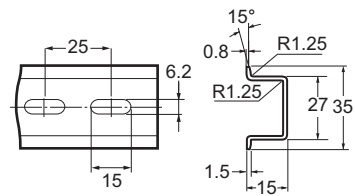

● **End Plate**

PFP-M (Two)

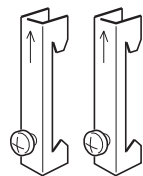

CLIPFIX 35 (Two)

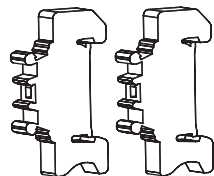

### 6-1-3 Installation Orientation

An EtherCAT Slave Terminal can be installed in any of the following six orientations.

(A) is the upright installation direction and (B) to (F) are installation directions other than upright.

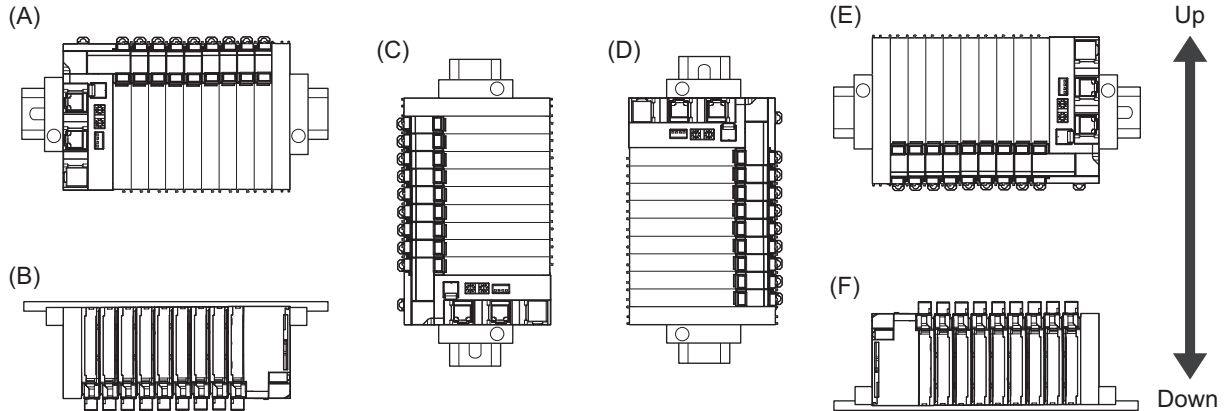

However, there are restrictions on the installation orientation of the EtherCAT Coupler Unit due to the ambient operating temperature and the NX Unit power supply capacity.

There are also installation orientation restrictions on the DIN Track of the EtherCAT Coupler Unit and restrictions to specifications that can result from the NX Units that are used.

For restrictions on the EtherCAT Coupler Unit, refer to *3-1-2 EtherCAT Coupler Unit Specifications* on page 3-2.

For restrictions on the installation orientation of NX Units, refer to *Installation orientation and restrictions* specified in the user's manuals for the NX Units.



#### Precautions for Safe Use

For installation orientations (C) and (D) in the above figure, support the cables, e.g., with a duct, so that the End Plate on the bottom is not subjected to the weight of the cables. The weight of the cables may cause the bottom End Plate to slide downward so that the Slave Terminal is no longer secured to the DIN Track, which may result in malfunctions.

## 6-1-4 Installing the EtherCAT Coupler Unit

This section describes how to install the EtherCAT Coupler Unit.



### Precautions for Safe Use

- Always turn OFF the power supply before installing the Unit.  
If the power supply is not OFF, the Unit may malfunction or may be damaged.
- Do not apply labels or tape to the Unit. When the Unit is installed or removed, adhesive or scraps may adhere to the pins in the NX bus connector, which may result in malfunctions.
- Do not touch the pins in the NX bus connector on the Unit. Dirt may adhere to the pins in the NX bus connector, which may result in malfunctions.

**NG**

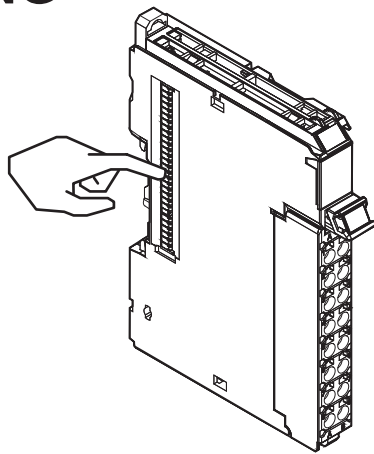

**NG**

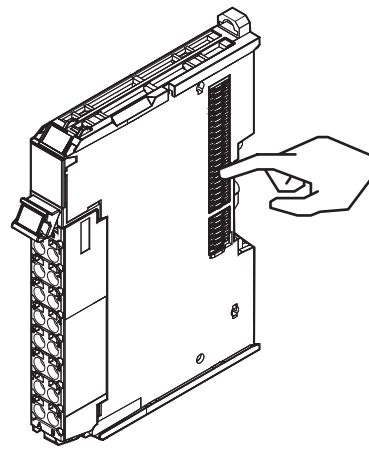

Example: NX Unit (12 mm width)

- Do not write on the EtherCAT Coupler Unit with ink within the restricted region that is shown in the following figure. Also do not get this area dirty. When the Unit is installed or removed, ink or dirt may adhere to the pins in the NX bus connector, which may result in malfunctions in the EtherCAT Slave Terminal.

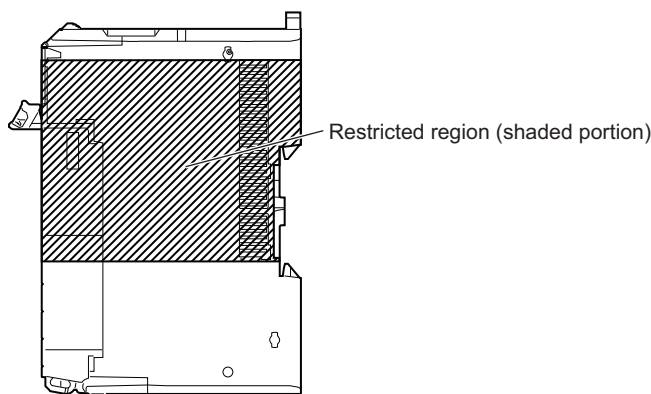

### Precautions for Correct Use

- When you handle the Unit, be careful not to touch or bump the pins in the NX bus connector.
- When you handle the Unit, be careful not to apply stress to the pins in the NX bus connector.  
If the Unit is installed and the power supply is turned ON when the pins in the NX bus connector are deformed, contact failure may cause malfunctions.

**1** Install the DIN Track.

- Using a PFP-50N/100N DIN Track

Use one M4 screw for each three holes in the DIN Track. There must be a screw for each interval of 105 mm or less. The screw tightening torque is 1.2 N·m.

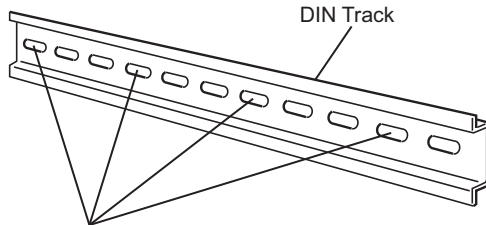

Use one screw for each three holes.

- Using an NS 35/7,5 PERF or NS 35/15 PERF DIN Track

Use one M6 screw for each four holes in the DIN Track. There must be a screw for each interval of 100 mm or less. The screw tightening torque is 5.2 N·m.

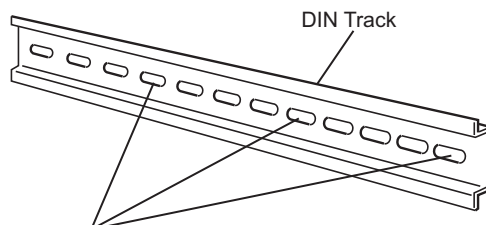

Use one screw for each four holes.

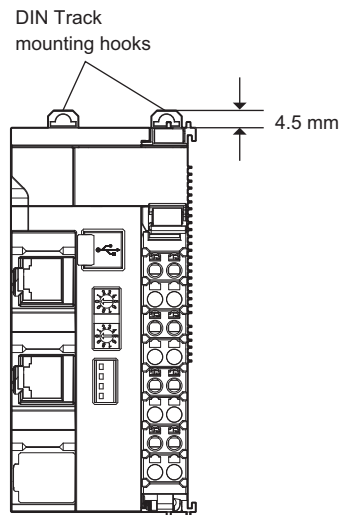
**2** Make sure that the two DIN Track mounting hooks on the EtherCAT Coupler Unit are in the locked position.

DIN Track Mounting Hooks in Locked Position

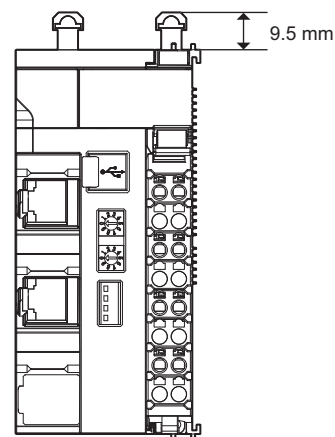

DIN Track Mounting Hooks in Unlocked Position

If the DIN Track mounting hooks are pressed down, they are in the locked position.

If the DIN Track mounting hooks are up, they are in the unlocked position.

If the DIN Track mounting hooks are unlocked, press them down into the locked position.

**3** Press the EtherCAT Coupler Unit firmly against the DIN Track until you hear the DIN Track mounting hook lock into place.

After you mount the EtherCAT Coupler Unit, check to be sure that it is securely mounted on the DIN Track.

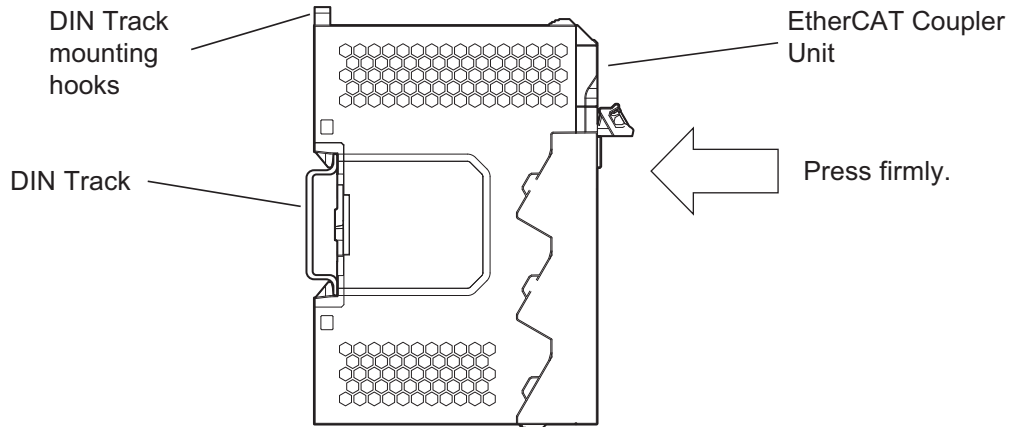

### Precautions for Correct Use

The EtherCAT Coupler Unit may not be mounted properly to the DIN Track if the protrusions on the left back of the EtherCAT Coupler Unit interfere with the screw that fixes the DIN Track as shown in the following figure.

When you mount the EtherCAT Coupler Unit to the DIN Track, avoid interference of the protrusions on the left back of the EtherCAT Coupler Unit with the screw on the DIN Track. (This applies to EtherCAT Coupler Units with lot numbers through December 2014.)

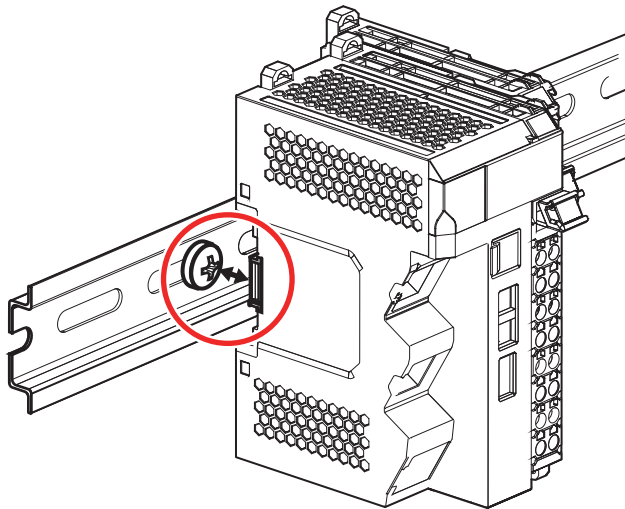

### Additional Information

It is not normally necessary to unlock the DIN Track mounting hooks when you mount the EtherCAT Coupler Unit. However, if you mount the EtherCAT Coupler Unit on a DIN Track that is not one of the recommended DIN Tracks, the DIN Track mounting hooks may not lock properly. If that happens, unlock the DIN Track mounting hooks at the start of the procedure, mount the Unit to the DIN Track, and then lock the DIN Track mounting hooks.

## 6-1-5 Installing and Connecting NX Units

This section describes how to mount NX Units to the EtherCAT Coupler Unit and how to connect NX Units to each other.



### Precautions for Safe Use

- Always turn OFF the power supply before mounting the NX Units. If the power supply is not OFF, the Unit may malfunction or may be damaged.
- Do not apply labels or tape to the Units. When the Units are installed or removed, adhesive or scraps may adhere to the pins in the NX bus connector, which may result in malfunctions.
- Do not touch the pins in the NX bus connector on the Unit. Dirt may adhere to the pins in the NX bus connector, which may result in malfunctions.

NG

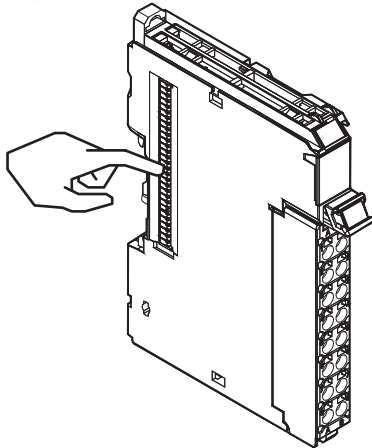

NG

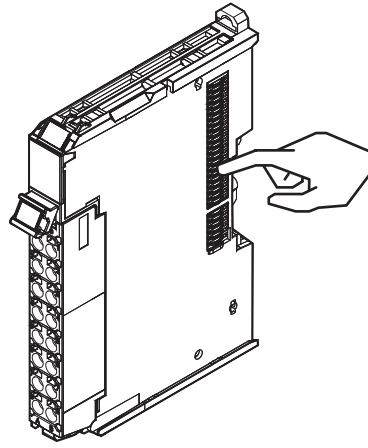

Example: NX Unit (12 mm width)

- Do not write on an NX Unit with ink within the restricted region that is shown in the following figure. Also do not get this area dirty. When the Unit is installed or removed, ink or dirt may adhere to the pins in the NX bus connector, which may result in malfunctions in the EtherCAT Slave Terminal.

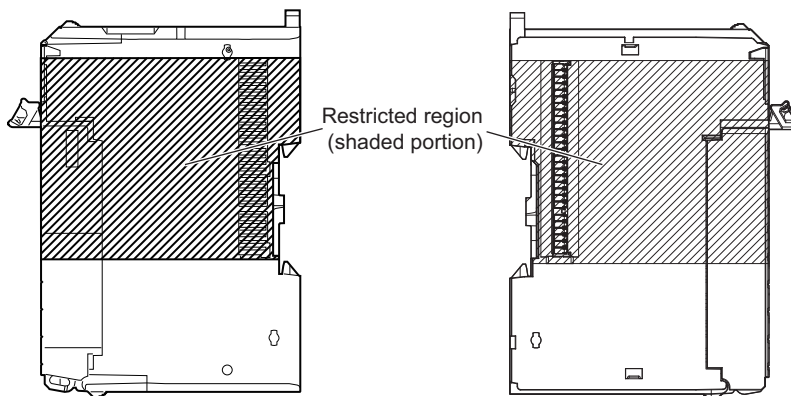

### Precautions for Correct Use

- When you mount an NX Unit to the EtherCAT Coupler Unit or when you connect NX Units to each other, always mount the Units one at a time on the DIN Track. If you connect NX Units to each other and attempt to mount them together to the DIN Track at the same time, the Units may separate from each other and fall.
- When you handle a Unit, be careful not to apply stress to the pins in the NX bus connector. If the Unit is installed and the power supply is turned ON when the pins in the NX bus connector are deformed, contact failure may cause malfunctions.
- When you handle a Unit, be careful not to touch or bump the pins in the NX bus connector.

## ● Mounting an NX Unit to the EtherCAT Coupler Unit

- 1 From the front of the EtherCAT Coupler Unit, engage the Unit hookup guides on the NX Unit with the Unit hookup guides on the EtherCAT Coupler Unit.

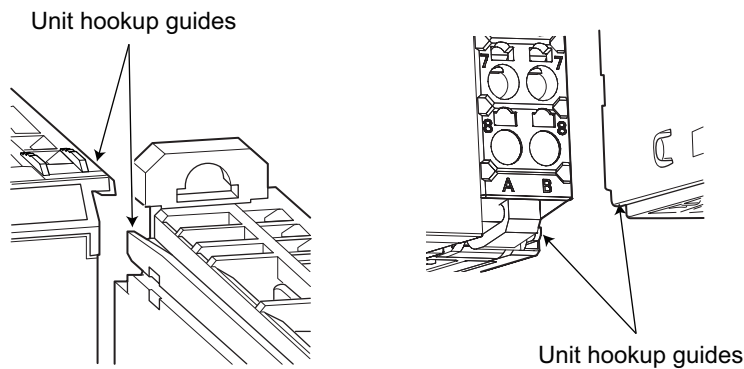

- 2 Slide the NX Unit in on the hookup guides.

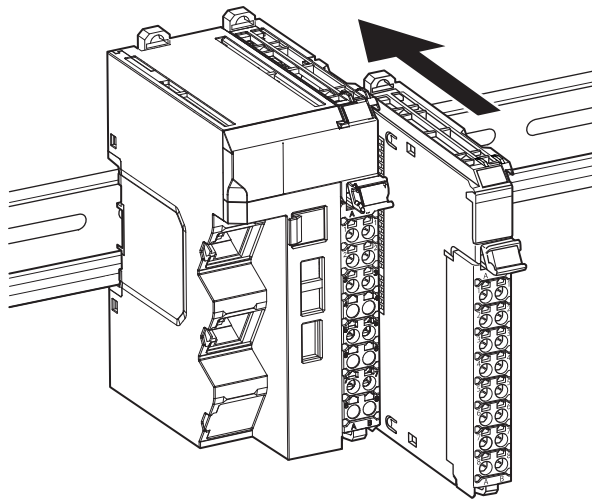

- 3 Press the NX Unit with a certain amount of force against the DIN Track until you hear the DIN Track mounting hook lock into place.  
When you mount the NX Unit, it is not necessary to release the DIN track mounting hook on the NX Unit.  
After you mount the NX Unit, make sure that it is locked to the DIN Track.



#### Additional Information

It is not normally necessary to unlock the DIN Track mounting hook when you mount the NX Unit. However, if you mount the NX Unit on a DIN Track that is not one of the recommended DIN Tracks, the DIN Track mounting hook may not lock properly. If that happens, unlock the DIN Track mounting hook at the start of the procedure, mount the NX Unit to the DIN Track, and then lock the DIN Track mounting hook.

#### ● Mounting NX Units to Each Other

Use the following procedure to mount NX Units to each other.

- 1 From the front of the previously mounted NX Unit, engage the Unit hookup guides on a new Unit with the Unit hookup guides on the previously mounted NX Unit.

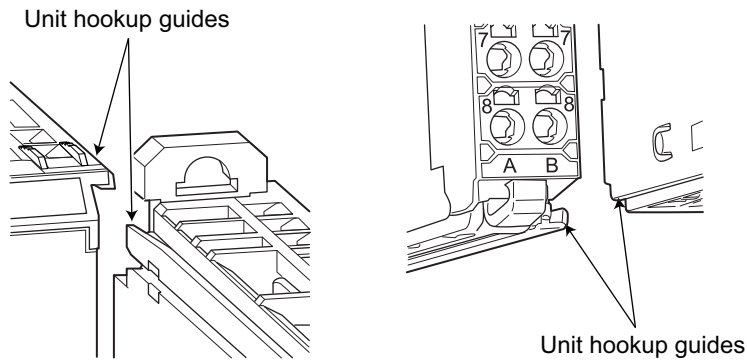

- 2** Slide the NX Unit in on the hookup guides.

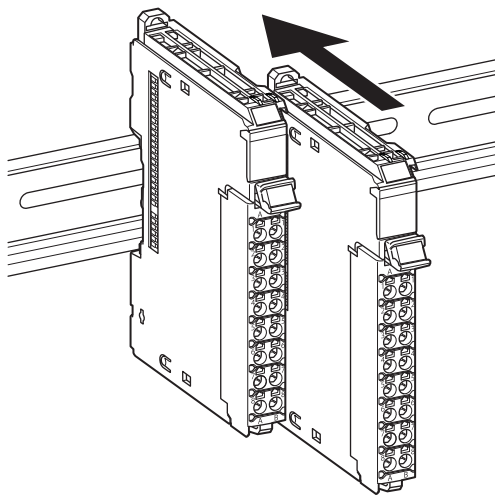

- 3** Press the NX Unit with a certain amount of force against the DIN Track until you hear the DIN Track mounting hook lock into place.  
When you mount the NX Unit, it is not necessary to release the DIN track mounting hook on the NX Unit.  
After you mount the NX Unit, make sure that it is locked to the DIN Track.



#### Additional Information

It is not normally necessary to unlock the DIN Track mounting hook when you mount the NX Unit. However, if you mount the NX Unit on a DIN Track that is not one of the recommended DIN Tracks, the DIN Track mounting hook may not lock properly. If that happens, unlock the DIN Track mounting hook at the start of the procedure, mount the NX Unit to the DIN Track, and then lock the DIN Track mounting hook.

### 6-1-6 Mounting the End Cover

Always mount an End Cover to the end of the Slave Terminal.



### Precautions for Safe Use

- Always turn OFF the power supply before mounting the End Cover. If the power supply is not OFF, the Unit may malfunction or may be damaged.
- Do not apply labels or tape to the Units. When the Units are installed or removed, adhesive or scraps may adhere to the pins in the NX bus connector, which may result in malfunctions.



### Precautions for Correct Use

Always mount an End Cover to the end of the EtherCAT Slave Terminal to protect the last NX Unit in the EtherCAT Slave Terminal. Not mounting the End Cover may result in malfunction or failure of the EtherCAT Slave Terminal.

- 1** From the front of the EtherCAT Slave Terminal, slide the End Cover in on the Unit hookup guides on the NX Unit on the right end of the EtherCAT Slave Terminal.
- 2** Press the End Cover firmly against the DIN Track until you hear it lock into place on the DIN Track.  
After you mount the End Cover, check to be sure that it is securely mounted on the DIN Track.

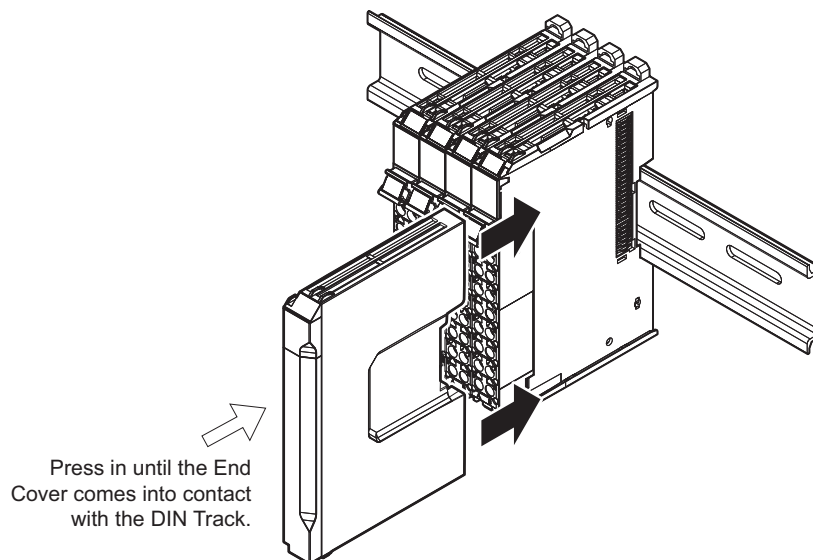



### Precautions for Correct Use

The End Cover may not be mounted properly to the DIN Track if the protrusions on the back of the End Cover that are marked in the left below figure interfere with the screw that fixes the DIN Track as shown in the right below figure.

When you mount the End Cover to the DIN Track, avoid interference of the protrusions on the back of the End Cover with the screw on the DIN Track. (This applies to End Covers provided with EtherCAT Coupler Units with lot numbers through December 2014.)

Protrusions on the back of End Cover    Interference of the protrusions with the screw

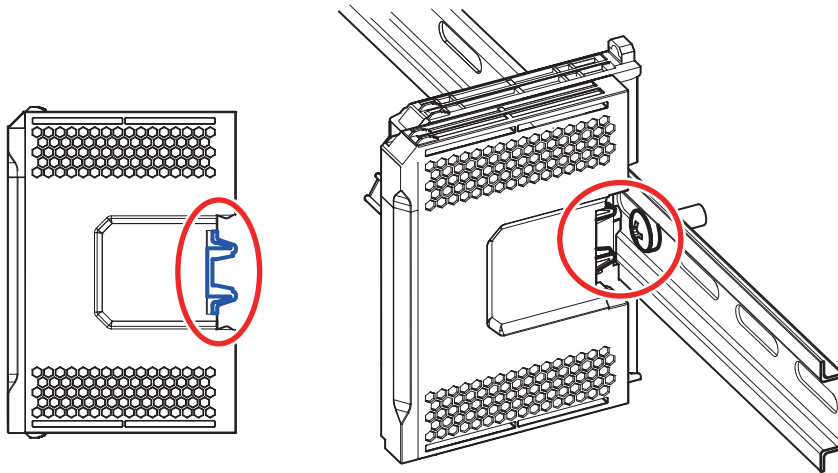

## 6-1-7 Mounting the End Plates

After you mount the End Cover, always secure the EtherCAT Slave Terminal with End Plates.



### Precautions for Correct Use

After you mount the EtherCAT Slave Terminal, always install an End Plate on each side of the Slave Terminal to secure the Slave Terminal. If you do not secure it, the EtherCAT Slave Terminal may be damaged or malfunction.

#### ● Using PFP-M (OMRON)

To mount an End Plate, 1) hook the bottom of it on the bottom of the DIN Track and 2) rotate the End Plate to hook the top of it on the top of the DIN Track.

Then tighten the screw to lock the End Plate in place.

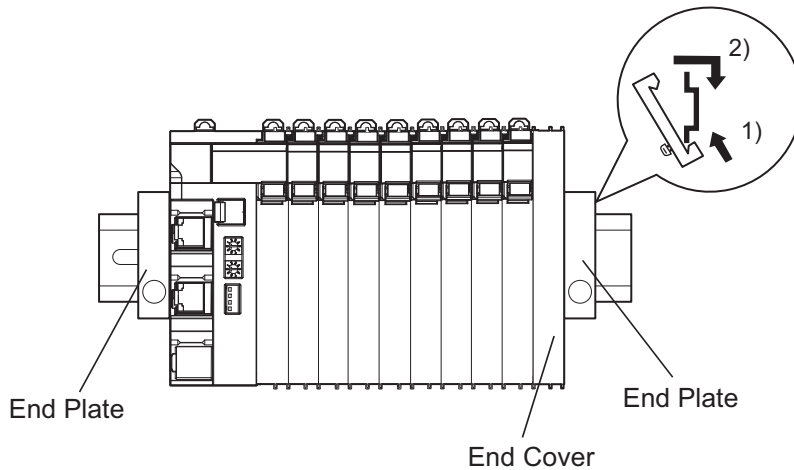

### ● Using CLIPFIX 35 (Phoenix Contact)

To mount an End Plate, 1) hook the top of it on the top of the DIN Track and 2) rotate the End Plate to hook the bottom of it on the bottom of the DIN Track. Press in until you hear the End Plate lock into place.

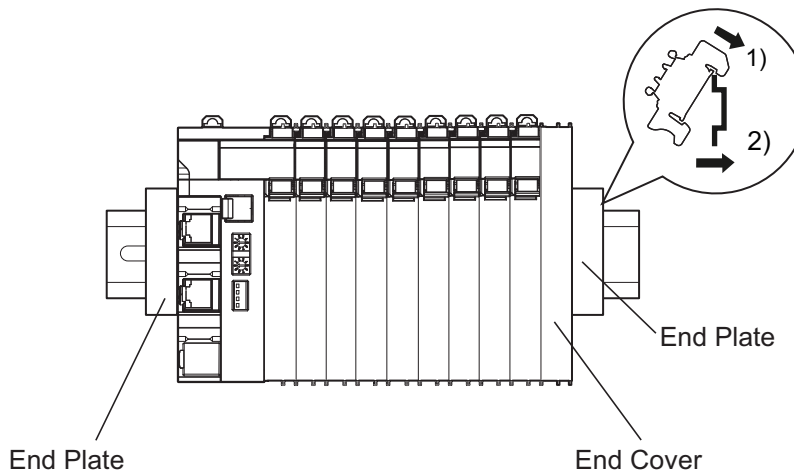

To remove an End Plate 1) insert the tip of a flat-blade screwdriver into groove "a" and 2) use "b" as a fulcrum and lift the end of the screwdriver, as shown in the following diagram.

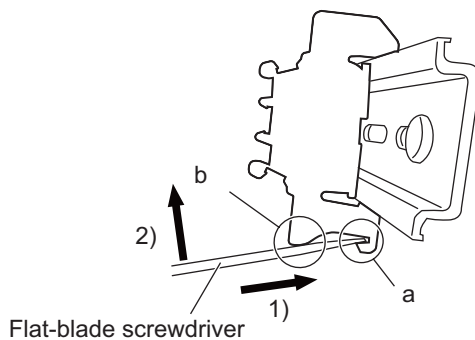

## 6-1-8 Attaching Markers

Markers can be attached to EtherCAT Coupler Units, NX Units, and terminal blocks on NX Units to identify them.

The plastic markers made by OMRON are installed for the factory setting. The ID information can be written on them.

Commercially available markers can also be installed.

Replace the markers made by OMRON if you use commercially available markers now.

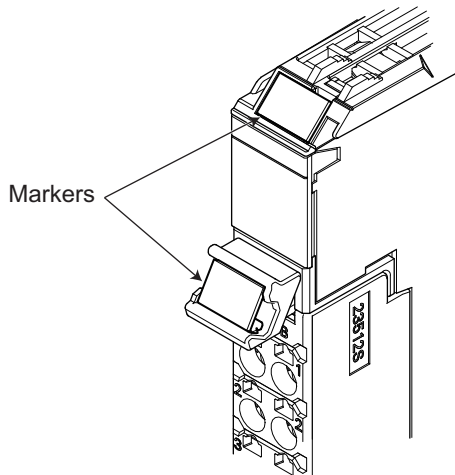

The marker attachment locations on the NX Units depend on the type of external connection terminals. Refer to the user's manual for the NX Units that you will use for the marker attachment locations.

### ● Installation Method

Insert the protrusions on the markers into the marker attachment locations on the EtherCAT Coupler Units, NX Units, and terminal blocks on NX Units.

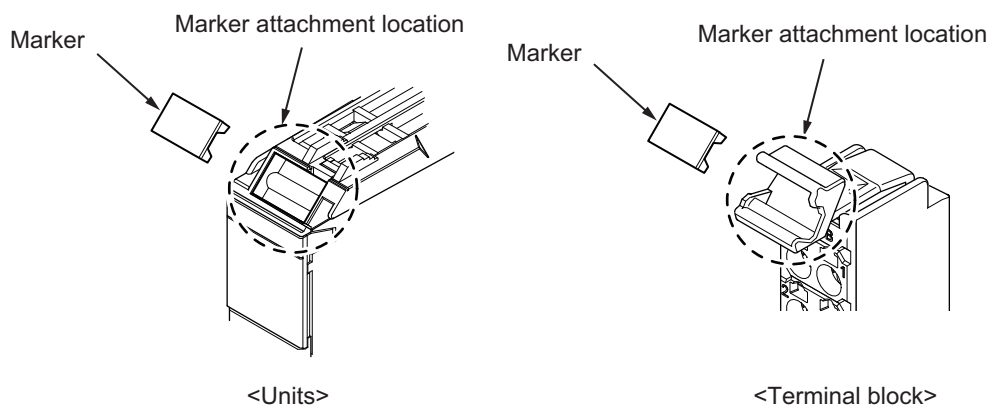

### ● Commercially Available Markers

Commercially available markers are made of plastic and can be printed on with a special printer. To use commercially available markers, purchase the following products.

Product name	Model number	
	Manufactured by Phoenix Contact	Manufactured by Weidmuller
Markers	UC1-TMF8	DEK 5/8
Special marker printer	UM EN BLUEMARK X1	PrintJet PRO

The markers made by OMRON cannot be printed on with commercially available special printers.

## 6-1-9 Removing Units



### Precautions for Safe Use

Always turn OFF the power supply before removing any Unit. If the power supply is not OFF, the Unit may malfunction or may be damaged.



### Precautions for Correct Use

- When removing an NX Unit, remove multiple Units together which include the one you want to remove. If you attempt to remove only one Unit, it is stuck and hard to pull out. Do not unlock the DIN track mounting hooks on all of the NX Units at the same time. If you unlock the DIN Track mounting hooks on all of the NX Units at the same time, all of the Units may come off.
- When you remove a Unit, be careful not to touch or bump the pins in the NX bus connector.

- 1 Use a flat-blade screwdriver to pull up the DIN Track mounting hook on the Unit to remove.

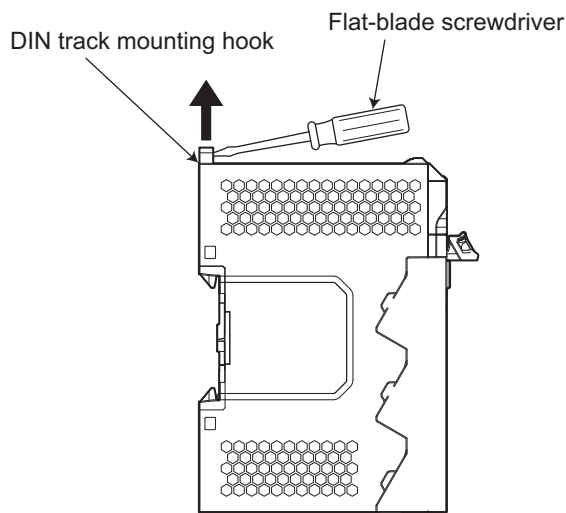

- 2 Remove the Unit with either (a) or (b) below.
  - a) For an EtherCAT Coupler Unit, place your fingers on the protrusions on the EtherCAT Coupler Unit and pull it straight forward.
  - b) For an NX Unit, place your fingers on the protrusions on more than one NX Unit, including the NX Unit to remove, and pull the NX Units straight forward.

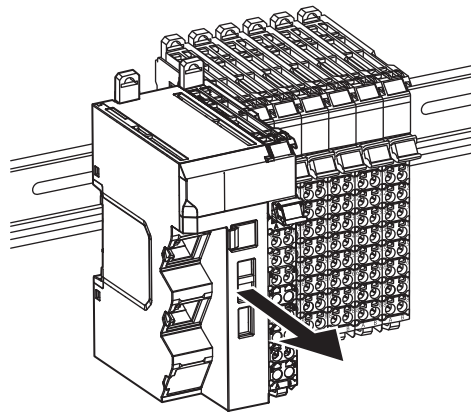
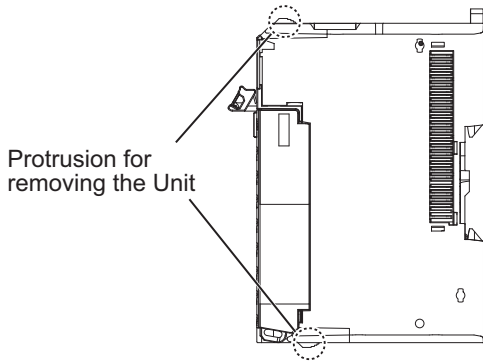

<EtherCAT Coupler Unit>

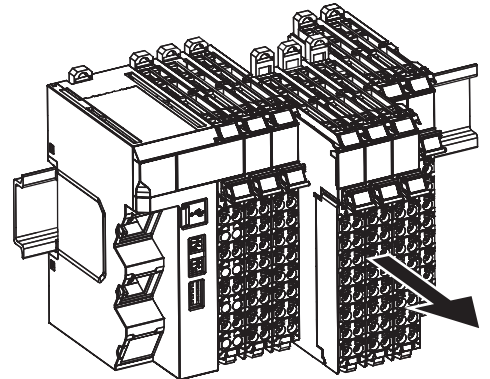

<NX Unit>

### 6-1-10 Assembled Appearance and Dimensions

#### Installation Dimensions

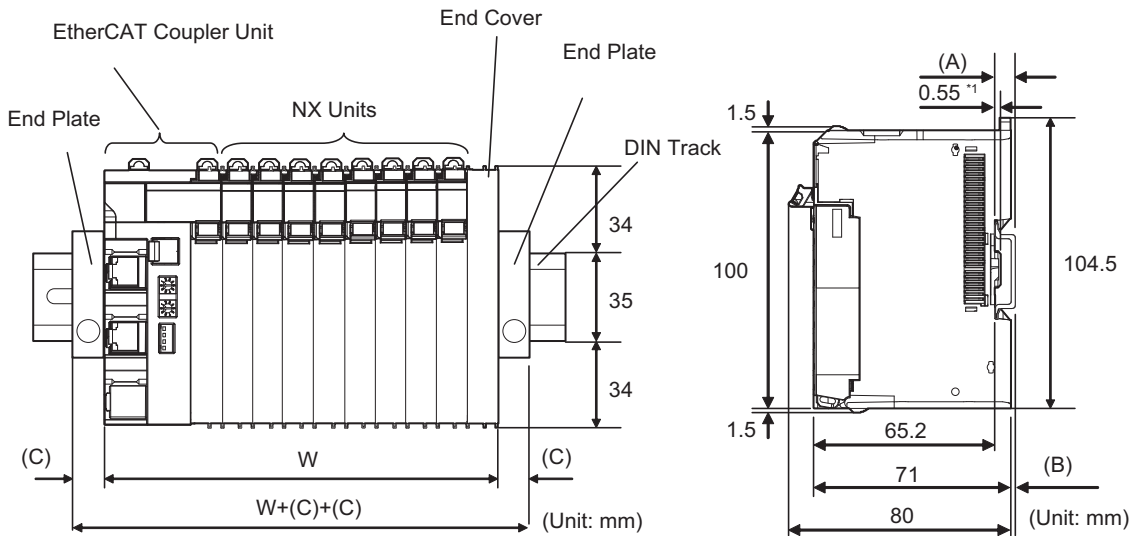

\*1. The dimension is 1.35 mm for Communications Coupler Units with lot numbers through December 2014 or for NX Units with 12-mm widths with lot numbers through December 2014.

W: Width of the EtherCAT Slave Terminal

W+ (C) + (C): Width of the EtherCAT Slave Terminal including the End Plates

DIN Track model	(A) DIN Track dimension	(B) Dimension from the back of the Unit to the back of the DIN Track
PFP-100N	7.3 mm	1.5 mm
PFP-50N	7.3 mm	1.5 mm
NS 35/7,5 PERF	7.5 mm	1.7 mm
NS 35/15 PERF	15 mm	9.2 mm

End Plate model	(C) End Plate dimension
PFP-M	10 mm
CLIPFIX 35	9.5 mm

### ● Calculation Example for the Configuration Width of an EtherCAT Slave Terminal

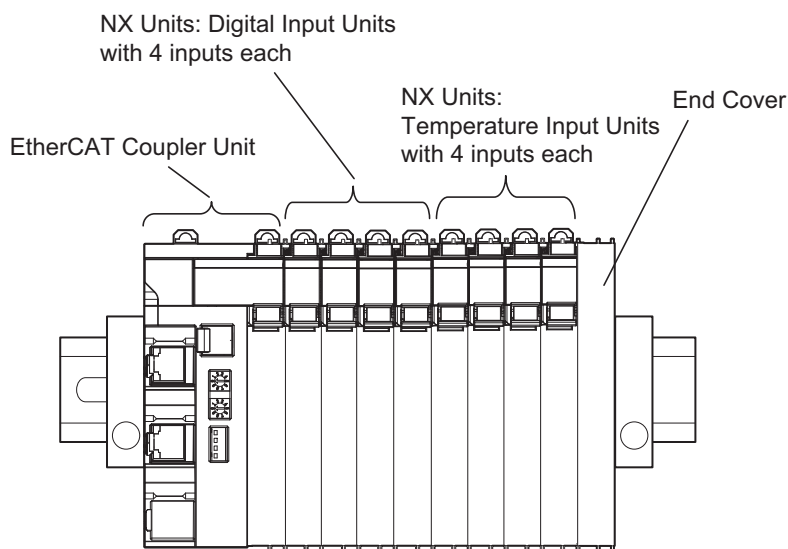

The widths of the Units in the example EtherCAT Slave Terminal configuration and the total configuration width are given below.

Name	Model	Unit width
EtherCAT Coupler Unit	NX-ECC201	46 mm
NX Units: Digital Input Units	NX-ID3317	12 mm × 4 Units
NX Units: Temperature Input Units	NX-TS3101	24 mm × 2 Units
End Cover	NX-END01	12 mm

$$\text{Total: } W = 46 + (12 \times 4) + (24 \times 2) + 12 = 154 \text{ mm}$$



### Additional Information

You can check the width of a Slave Terminal when you create the Unit configuration on the Edit Slave Terminal Configuration Tab Page on the Sysmac Studio. You can display the width on the right of the Slave Terminal on the Edit Slave Terminal Configuration Tab Page on the Sysmac Studio. Click  to display the width.

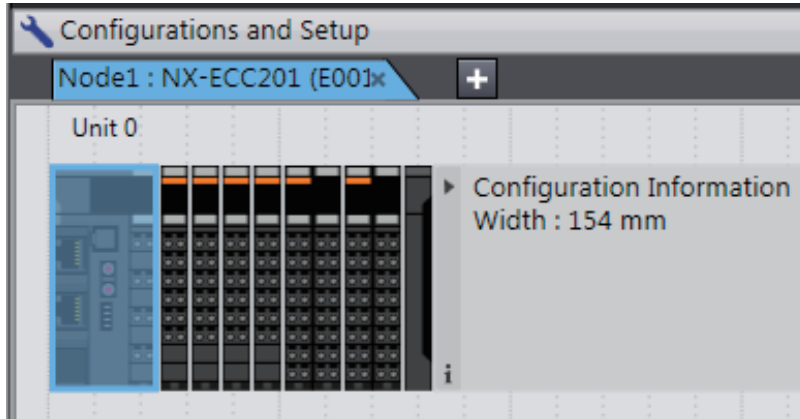

## Installation Height

The installation height of the EtherCAT Slave Terminal depends on the model of DIN Track and on the models of NX Units that are mounted.

Also, additional space is required for the cables that are connected to the Unit. Allow sufficient depth in the control panel and allow extra space when you mount the EtherCAT Slave Terminal.

The following figure shows the dimensions from the cables connected to the EtherCAT Coupler Unit to the back of the Unit.

This is the installation height without the DIN Track of the EtherCAT Coupler Unit.

Refer to *Installation Dimensions* on page 6-20 for the influence on the installation height on the DIN Track.

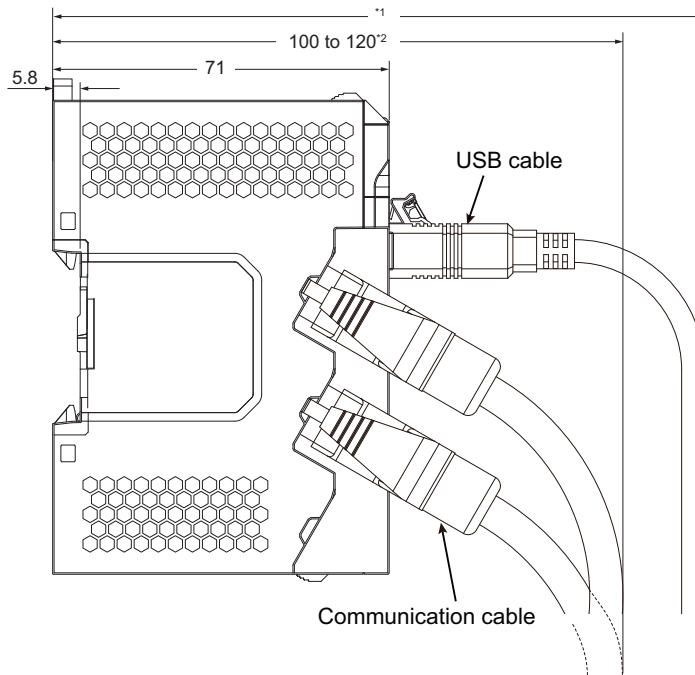

- \*1. This dimension depends on the specifications of the commercially available USB certified cable. Check the specifications of the USB cable that is used.
- \*2. Dimension from Back of Unit to Communications Cables
  - 100 mm: When an MPS588-C Connector is used.
  - 120 mm: When an XS6G-T421-1 Connector is used.

As shown above, the installation height depends on the USB cable specifications when a USB cable is used to connect the Sysmac Studio Support Software to the EtherCAT Coupler Unit. Check the specifications of the USB cable that is used.

For the installation height of NX Units, refer to the user's manuals for the NX Units.

## 6-2 Control Panel Installation

To ensure system reliability and safety, the system must be designed and configured according to the installation environment (temperature, humidity, vibration, shock, corrosive gases, overcurrent, noise, etc.).

### 6-2-1 Temperature

Panels have been reduced in size due to space-saving and miniaturization in devices and systems, and the temperature inside the panel may be at least 10 to 15°C higher than outside the panel. Implement the following measures against overheating at the installation site and in the panel, and allow a sufficient margin for the temperature.

#### High Temperatures

Use the following cooling methods as required, taking into account the ambient temperature and the amount of heating inside the panel.

##### ● Natural Cooling

Natural cooling relies on natural ventilation through slits in the panel, rather than using cooling devices such as fans or coolers.

When using this method, observe the following points.

- Do not install the EtherCAT Slave Terminal at the top of the panel, where hot air tends to stagnate.
- To provide ventilation space above and below the EtherCAT Slave Terminal, leave sufficient distance from other devices, wiring ducts, etc.
- Do not install the EtherCAT Slave Terminal directly above heat-generating equipment, such as heaters, transformers, and devices with high resistance.
- Do not install the EtherCAT Slave Terminal in a location exposed to direct sunlight.

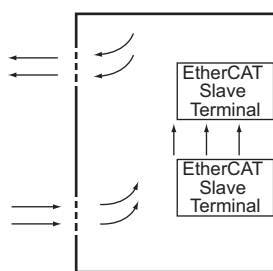

Natural Cooling

- **Forced Ventilation by Fan at Top of Panel**

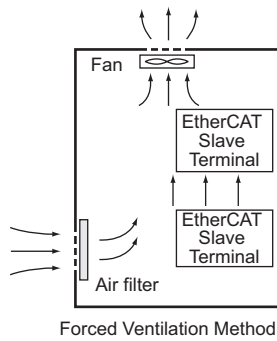

- **Forced Air Circulation by Fan in Closed Panel**

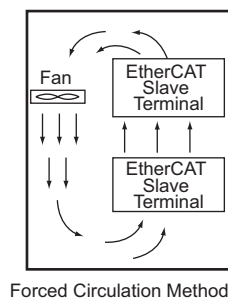

- **Room Cooling (Cooling the Entire Room Where the Control Panel Is Located)**

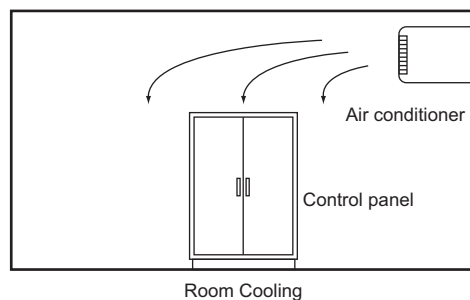

## Low Temperatures

The EtherCAT Slave Terminal may not start normally if the temperature is below 0°C when the power is turned ON.

Maintain an air temperature of at least approximately 5°C inside the panel, by implementing measures such as installing a low-capacity space heater in the panel.

Alternatively, leave the EtherCAT Slave Terminal power ON to keep the EtherCAT Slave Terminal warm.

### 6-2-2 Humidity

Rapid temperature changes can cause condensation to occur, resulting in malfunctioning due to short-circuiting.

When there is a possibility of this occurring, take measures against condensation, such as leaving the EtherCAT Slave Terminal power ON at night or installing a heater in the control panel to keep it warmer.

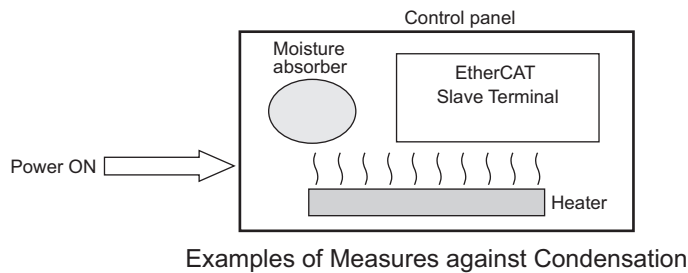

### 6-2-3 Vibration and Shock

The EtherCAT Slave Terminal is tested for conformity with the sine wave vibration test method (IEC 60068-2-6) and the shock test method (IEC 60068-2-27) of the Environmental Testing for Electrotechnical Products. It is designed so that malfunctioning will not occur within the specifications for vibration and shock. If, however, the EtherCAT Slave Terminal is to be used in a location in which it will be directly subjected to regular vibration or shock, then implement the following countermeasures:

- Separate the control panel from the source of the vibration or shock. Or secure the EtherCAT Slave Terminal and the panel with rubber padding to prevent vibration.
- Make the building or the floor vibration-resistant.
- To prevent shock when other devices in the panel such as electromagnetic contactors operate, secure either the source of the shock or the EtherCAT Slave Terminal with rubber padding.

### 6-2-4 Atmosphere

Using the EtherCAT Slave Terminal in any of the following locations can cause defective contact with connectors and corrosion of components. Implement countermeasures such as purging the air as required.

- In locations exposed to dust, dirt, salt, metal powder, soot, or organic solvents, use a panel with an airtight structure. Be careful of temperature increases inside the panel.
- In locations exposed to corrosive gas, purge the air inside the panel to clear the gas and then pressurize the inside of the panel to prevent gas from entering from outside.
- In locations where flammable gas is present, either use an explosion-protected construction or do not use the EtherCAT Slave Terminal.

### 6-2-5 Electrical Environment

When installing or wiring devices, make sure that there will be no danger to people and that noise will not interfere with electrical signals.

## Installation Location of EtherCAT Slave Terminals

Install the EtherCAT Slave Terminal as far away as possible from high-voltage (600 V or higher) and power devices to ensure safe operation and maintenance.

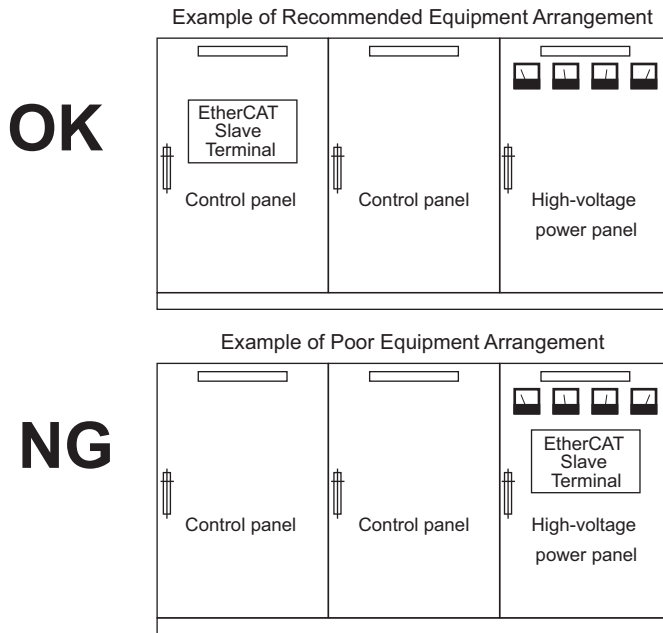

Examples of Equipment Arrangement in Panel with High-voltage Devices

## Arrangement of EtherCAT Slave Terminal and Cables

Observe the following points.

- The coils and contacts in electromagnetic contactors and relays in an external circuit are sources of noise. Do not install them close to the EtherCAT Slave Terminal. Locate them at least 100 mm away from the EtherCAT Slave Terminal.

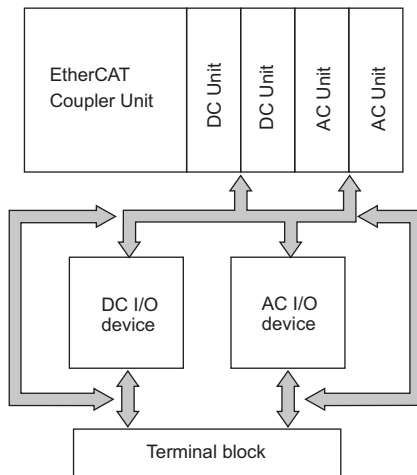

Example of Arrangement in Panel

## Wire Layout for the Power Supply System

Observe the following points when wiring the power supply system.

- Separate the EtherCAT Slave Terminal power supply from the I/O device power supply and install a noise filter near the power supply feed section.

- Use an isolating transformer to significantly reduce noise between the EtherCAT Slave Terminal and the ground. Install the isolating transformer between a power supply and the noise filter, and do not ground the secondary coil of the transformer.
- Keep the wiring between the transformer and the EtherCAT Slave Terminal as short as possible, twist the wires well, and keep the wiring separate from high-voltage and power lines.

### ● Supplying I/O Power from the NX Bus

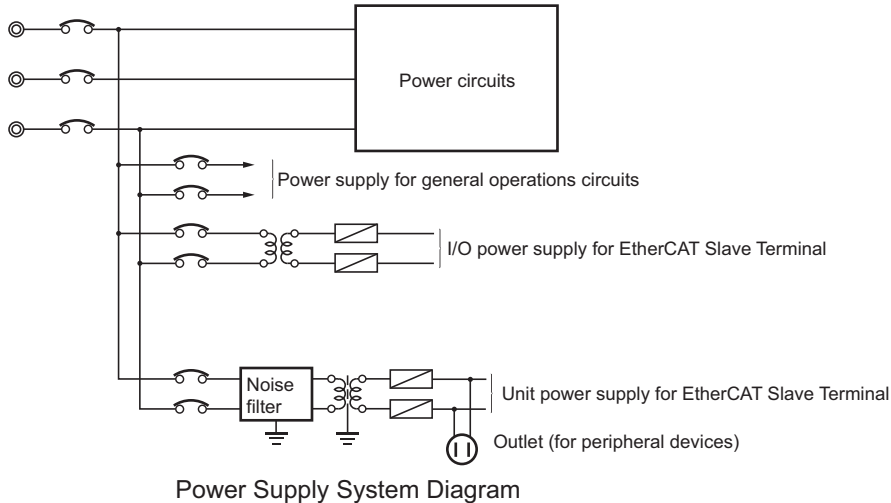

### ● Supplying I/O Power from External Sources

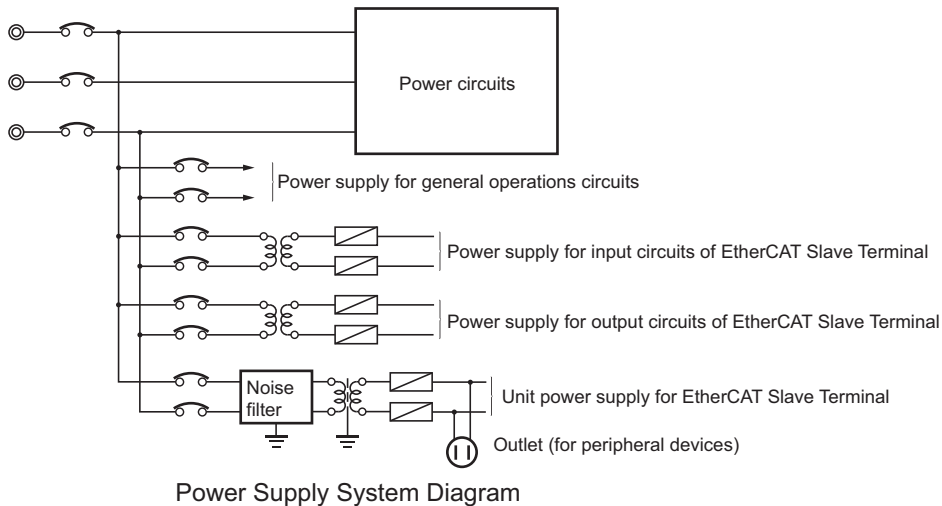

## Wiring External I/O Signal Lines

Observe the following points when wiring external I/O signal lines.

- To absorb reverse electromotive force when an inductive load is connected to an output signal, connect a surge suppressor near the inductive load in an AC circuit, or connect a diode near the inductive load in a DC circuit.

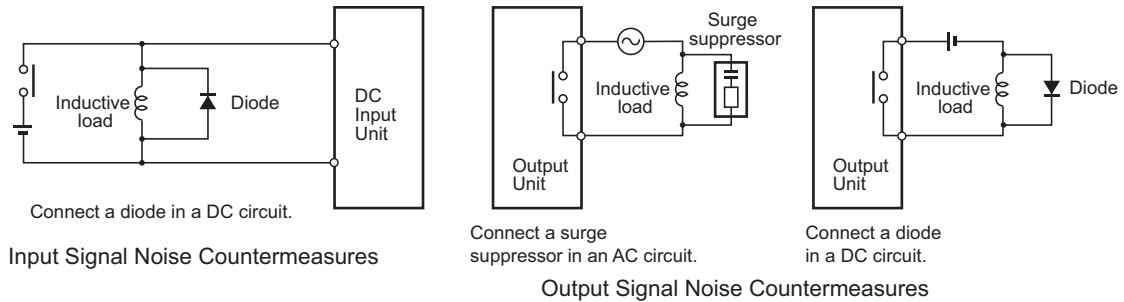

- Never bundle I/O cables with high-voltage or power lines, and do not route them in close proximity or parallel to such lines. If output signal lines must be routed in close proximity to such lines, place them in separate ducts or conduits. Be sure to ground the ducts or conduits.

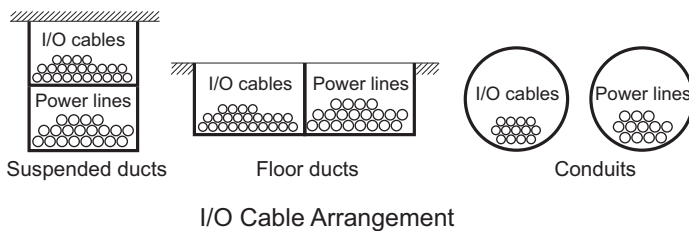

- If the signal lines and power lines cannot be routed in separate ducts, use shielded cable. Connect the shield to the ground terminal at the EtherCAT Slave Terminal, and leave it unconnected at the input device.
- Wire the lines so that common impedance does not occur. Such wiring will increase the number of wires, so use common return circuits. Use thick wires with sufficient allowance for the return circuits, and bundle them with lines of the same signal level.
- For long I/O lines, wire the input and output signal lines separately.
- Use twisted-pair wires for pilot lamps (and particularly lamps with filaments).
- If noise causes malfunctions, use countermeasures, such as CR surge absorbers and diodes, for noise sources of input devices and output load devices, as required.

## External Wiring

Wiring, and noise countermeasures in particular, are based on experience, and it is necessary to closely manage wiring based on experience and information in the manuals.

### ● Wiring Routes

Each of the following combinations includes different signal types, properties, or levels. They will cause the signal-to-noise ratio to drop due to factors such as electrical induction. As a general rule when wiring, either use separate cables or separate wiring routes for these items. Future maintenance operations and changes to the system will also be made easier by carefully organizing the wiring from the start.

- Power lines and signal lines
- Input signals and output signals
- Analog signals and digital signals
- High-level signals and low-level signals
- Communications lines and power lines
- DC signals and AC signals
- High-frequency devices (such as Inverters) and signal lines (communications)

## ● Wiring

Observe the following points when wiring power supply and signal cables.

- When routing signal cables with differing characteristics through the same duct, always keep them separated.
- As much as possible, avoid routing multiple power supply lines through the same duct. If it cannot be avoided, then construct a partition between them in the duct and ground the partition.

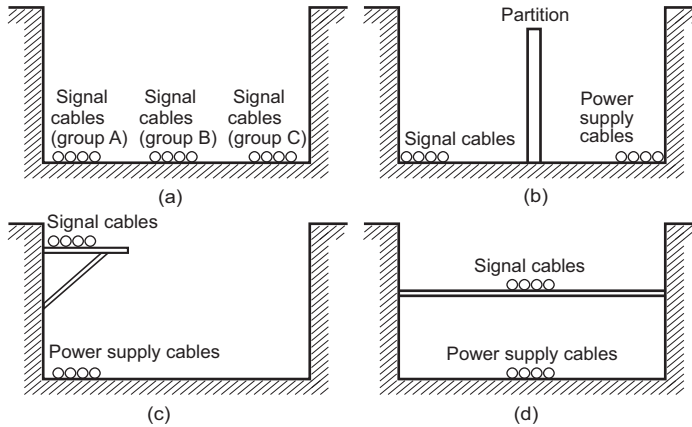

Partitioning Methods for Signal and Power Supply Cables

- To avoid overheating the conduits when using conduits for wiring, do not place wires for a single circuit in separate conduits.

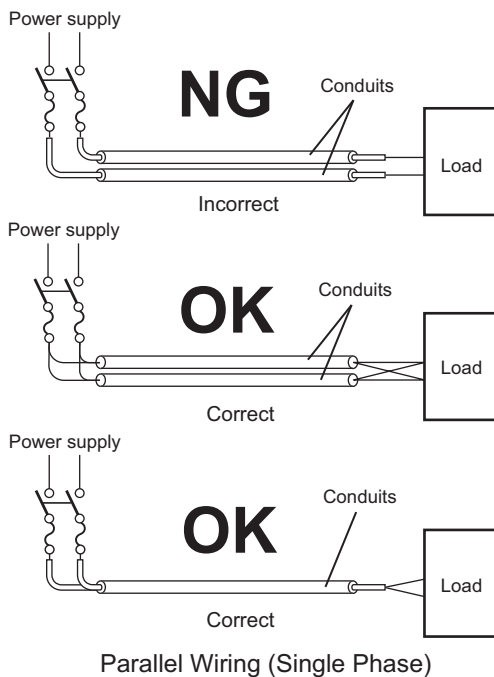

- Power cables and signal cables adversely affect each other. Do not wire them in parallel.
- Noise induction may occur if the EtherCAT Slave Terminal is installed in a panel that includes high-voltage devices. Whenever possible, wire and install them separately.
- Either install the EtherCAT Slave Terminal a minimum of 200 mm away from high-voltage lines or power lines, or place the high-voltage lines or power lines in metal tubing and completely ground the metal tubing to 100  $\Omega$  or less.

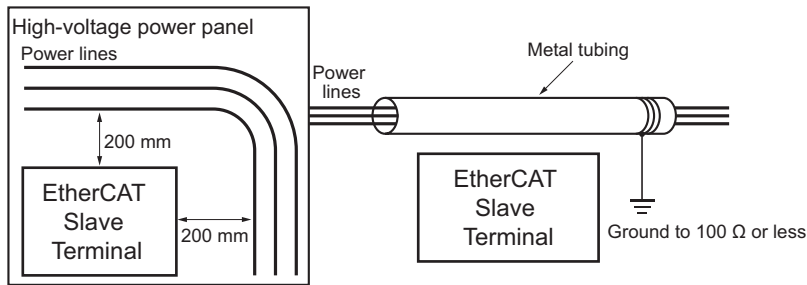

Example: Separating EtherCAT Slave Terminal from Power Lines

### ● Other Precautions

Some models of Digital Input Units and Digital Output Units have polarity. Make sure that you wire the polarity correctly.

## 6-2-6 Grounding

Grounding has the following two purposes.

- **Protective Grounding**  
Protective grounding is done to ensure safety. It is intended to prevent electrical shock by grounding the electrical potential that is generated by factors such as leakage, induction, or failure.
- **Functional Grounding**  
Functional grounding is done to protect device and system functions, including prevention of noise from external sources, or prevention of noise from devices or equipment that could have harmful effects on other devices or equipment.

Grounding requirements sometimes depend on the situation, and they may be found based on experimentation. It is important to sufficiently check the particular circumstances before grounding.

## Wire Layout for the Power Supply System

### ● Principles of One-point Grounding

For devices to operate properly, the reference potential between the devices must be stabilized. Use one-point grounding so that noise current does not flow to ground lines between the devices.

Whenever possible, use an independent ground (with the ground pole separated by a minimum of 10 m from any other ground pole).

- Ground to 100  $\Omega$  or less, and if possible use a separate ground from those of other devices. (See following figure (a).)
- If using an independent ground is not possible, then use a common ground as shown in figure (b). Connect to the ground pole of the other device.
- Never connect to the same ground as a device that draws a large amount of power, such as a motor or inverter. Ground the devices separately to avoid mutually adverse influences.
- To prevent electrical shock, do not connect to ground poles to which multiple devices are connected.
- Use a ground pole as close to the EtherCAT Slave Terminal as possible and keep the ground line as short as possible.

## ● Grounding Methods

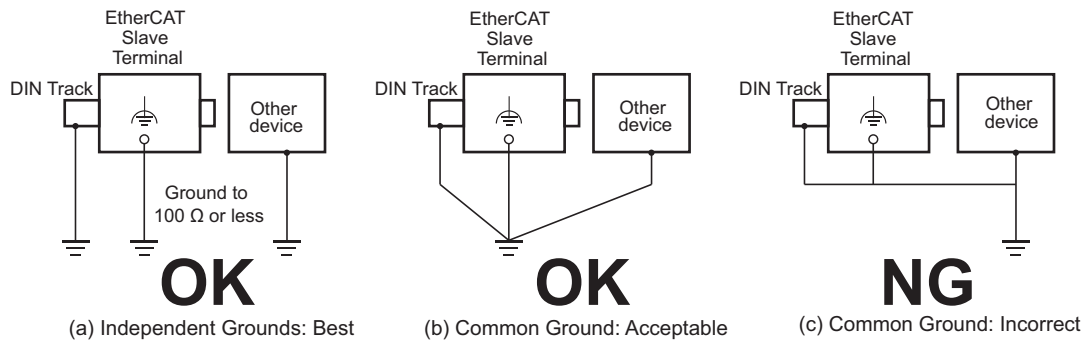

If the DIN Track is made of steel and the surface is not treated to produce an insulating material, you can omit grounding the functional ground terminal on any Unit that has one, as shown in the following figures.

### • DIN Track Made of Steel and Surface Not Insulated

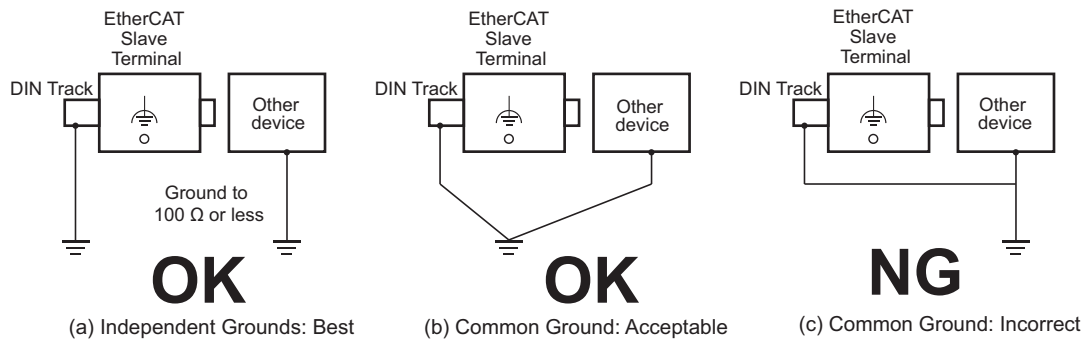

## ● Precautions when Grounding

- To prevent influence from leakage current from other electrical devices, electrically isolate the panel in which the EtherCAT Slave Terminal is housed from other devices.
- If high-frequency equipment is present, then ground not only the high-frequency equipment but also the panel itself in which the EtherCAT Slave Terminal is housed.
- To ground the shield wire when using shielded cables for I/O wiring, wire the ground according to the shield treatment specifications for the NX Unit that is used.  
Wire communications cables according to the shield treatment specifications for the Unit.



# Wiring

This section describes how to wire the EtherCAT Slave Terminal.

---

<b>7-1</b>	<b>EtherCAT Network Wiring.....</b>	<b>7-2</b>
7-1-1	Installation Precautions .....	7-2
7-1-2	Preparations for Installation.....	7-2
7-1-3	Pin Arrangement of Communications Connectors on the EtherCAT Coupler Unit .....	7-4
7-1-4	Connecting Communications Cables and Connectors.....	7-5
7-1-5	Connecting Communications Cables .....	7-5
<b>7-2</b>	<b>Connecting the Power Supply and Ground Wires .....</b>	<b>7-7</b>
7-2-1	Wiring the EtherCAT Coupler Unit.....	7-7
7-2-2	Wiring the Power Supply to the EtherCAT Slave Terminal.....	7-8
7-2-3	Grounding the EtherCAT Slave Terminal .....	7-8
7-2-4	Precautions for Wiring the EtherCAT Slave Terminal Together with Computers and Other Peripheral Devices.....	7-12
7-2-5	Wiring to the Screwless Clamping Terminal Block .....	7-13
<b>7-3</b>	<b>Connecting USB Cable .....</b>	<b>7-27</b>
<b>7-4</b>	<b>Wiring External Signal Lines.....</b>	<b>7-29</b>

# 7-1 EtherCAT Network Wiring

This section describes how to install the EtherCAT network.

## 7-1-1 Installation Precautions

Basic precautions for the installation of EtherCAT networks are provided below.

### Precautions when Installing a Network

- When you install an EtherCAT network, take sufficient safety precautions and perform the installation according to all applicable standards and specifications.  
An expert well versed in safety measures and the standards and specifications should be asked to perform the installation.
- Do not install EtherCAT network equipment near sources of noise.  
If the network must be installed in an area with noise, take steps to address the noise, such as placing equipment in metal cases.

### Precautions when Installing Communications Cables

- Check the following items on the communications cables that are used in the network.  
Are there any breaks?  
Are there any shorts?  
Are there any connector problems?
- When you connect the cable to the communications connectors on devices, firmly insert the communications cable connector until it locks in place.
- Do not lay the communications cables together with high-voltage lines.
- Do not lay the communications cable near devices that generate noise.
- Do not lay the communications cables in locations subject to high temperatures or high humidity.
- Do not lay the communications cables in locations subject to excessive dust, oil mist, or other contaminants.
- There are limitations on the bending radius of communications cables. Check the specifications of the communications cable for the bending radius.

## 7-1-2 Preparations for Installation

Prepare the following devices.

Product	Remarks
Twisted-pair cable (Cables with the following connectors can also be used.)	100BASE-TX (Category 5 or higher) Double shielding with aluminum tape and braiding
RJ45 connectors	Shielded

Recommended products are given in the following tables.

## Cables with Connectors

### ● Sizes and Conductor Pairs: AWG 27 × 4 Pairs

Product name	Manufacturer	Length (m) <sup>*1</sup>	Model
Standard type Cables with Connectors on Both Ends (RJ45/RJ45)	OMRON Corporation	0.3	XS6W-6LSZH8SS30CM-Y
		0.5	XS6W-6LSZH8SS50CM-Y
		1	XS6W-6LSZH8SS100CM-Y
		10	XS6W-6LSZH8SS1000CM-Y

\*1. Refer to the *XS5/XS6 Industrial Ethernet Connectors Catalog (Cat. No. G019)* for the latest lineup of these Cables.

### ● Sizes and Conductor Pairs: AWG 22 × 2 Pairs

Product name	Manufacturer	Length (m) <sup>*1</sup>	Model
Rugged type Cables with Connectors on Both Ends (RJ45/RJ45)	OMRON Corporation	0.3	XS5W-T421-AMD-K
		0.5	XS5W-T421-BMD-K
		1	XS5W-T421-CMD-K
		2	XS5W-T421-DMD-K
		5	XS5W-T421-GMD-K
		10	XS5W-T421-JMD-K
Rugged type Cables with Connectors on Both Ends (M12 Straight/M12 Straight) Shield Strengthening cable	OMRON Corporation	0.3	XS5W-T421-AM2-SS
		0.5	XS5W-T421-BM2-SS
		1	XS5W-T421-CM2-SS
		2	XS5W-T421-DM2-SS
		5	XS5W-T421-GM2-SS
		10	XS5W-T421-JM2-SS
Rugged type Cables with Connectors on Both Ends (M12 Straight/RJ45) Shield Strengthening cable	OMRON Corporation	0.3	XS5W-T421-AMC-SS
		0.5	XS5W-T421-BMC-SS
		1	XS5W-T421-CMC-SS
		2	XS5W-T421-DMC-SS
		5	XS5W-T421-GMC-SS
		10	XS5W-T421-JMC-SS

\*1. Refer to the *XS5/XS6 Industrial Ethernet Connectors Catalog (Cat. No. G019)* for the latest lineup of these Cables.

## Cables and Connectors

### ● Sizes and Conductor Pairs: AWG 24 × 4 Pairs

Part name	Manufacturer	Model
Cables	Hitachi Metals, Ltd.	NETSTAR-C5E SAB 0.5 × 4P CP <sup>*1</sup>
	Kuramo Electric Co., Ltd.	KETH-SB <sup>*1</sup>
	SWCC Showa Cable Systems Co., Ltd.	FAE-5004 <sup>*1</sup>
	JMACS Japan Co., Ltd.	IETP-SB <sup>*1</sup>

Part name	Manufacturer	Model
RJ45 connectors	Panduit Corporation	MPS588-C*1

\*1. We recommend that you use combinations of the above Cables and Connectors.

### ● Sizes and Conductor Pairs: AWG 22 × 2 Pairs

Part name	Manufacturer	Model
Cables	Kuramo Electric Co., Ltd.	KETH-PSB-OMR*1
	JMACS Japan Co., Ltd.	PNET/B*1
	SWCC Showa Cable Systems Co., Ltd.	FAE-5002*1
RJ45 Assembly Connectors	OMRON Corporation	XS6G-T421-1*1

\*1. We recommend that you use combinations of the above Cables and Connectors.



#### Precautions for Correct Use

- The maximum length between nodes is 100 m. However, some cables are specified for less than 100 m. Generally speaking, if the conductors are twisted wire rather than solid wire, transmission performance will be lower, and reliable communications may not be possible at 100 m. Confirm details with the cable manufacturer.
- When selecting a connector, confirm that it is applicable to the cable that will be used. Confirm the following items: Conductor size, conductor type (solid wire or twisted wire), number of twisted pairs (2 or 4), outer diameter, etc.

## 7-1-3 Pin Arrangement of Communications Connectors on the EtherCAT Coupler Unit

The pin arrangement of the EtherCAT Coupler Unit communications connectors is given below.

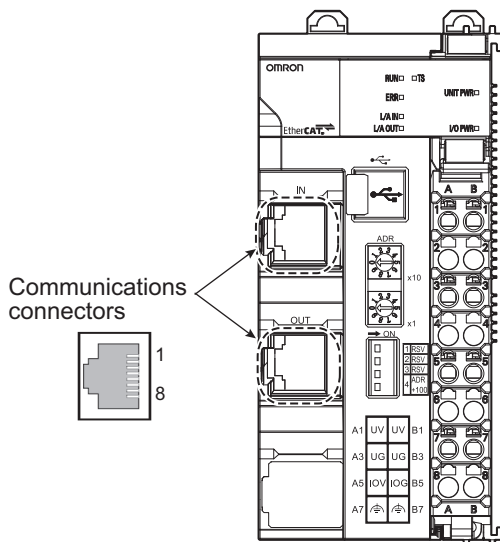

Pin No.	Signal name	Abbreviation
1	Send data +	TD+
2	Send data -	TD-
3	Receive data +	RD+
4	Not used -	---
5	Not used -	---

Pin No.	Signal name	Abbreviation
6	Receive data –	RD–
7	Not used –	---
8	Not used –	---

### 7-1-4 Connecting Communications Cables and Connectors

Use straight connections for the communications cables and connectors, as shown below.

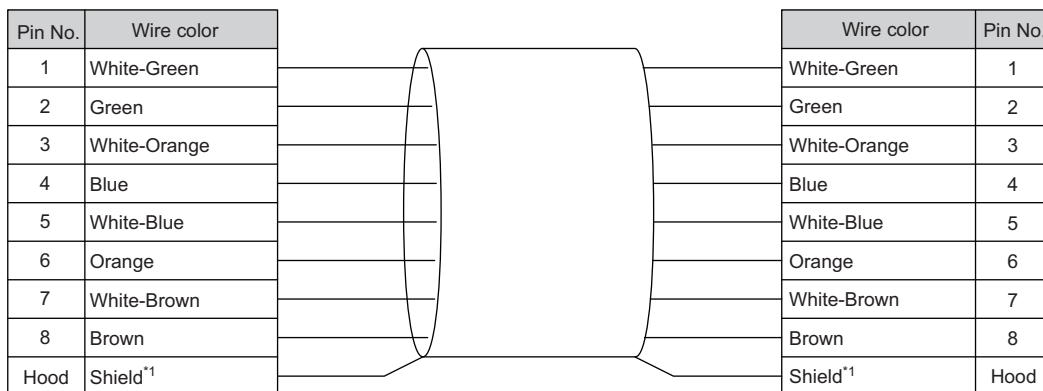
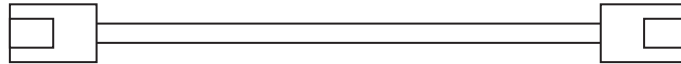

\*1. Connect the cable shield wire to the connector hood at both ends of the cable.



#### Additional Information

There are two connection methods for Ethernet cables: *T568A* and *T568B*.

The *T568A* connection method is shown in the above figure, but the *T568B* connection method can also be used.

### 7-1-5 Connecting Communications Cables

Cable connections can be made freely in EtherCAT networks.

The following example shows daisy-chain connections.

Connect the communications cable from the EtherCAT master to the input port on the first EtherCAT Slave Terminal, and then connect another communications cable from the output port on the first EtherCAT Slave Terminal to the input port on the next EtherCAT Slave Terminal.

Do not connect anything to the output port of the EtherCAT Slave Terminal at the end of the network.

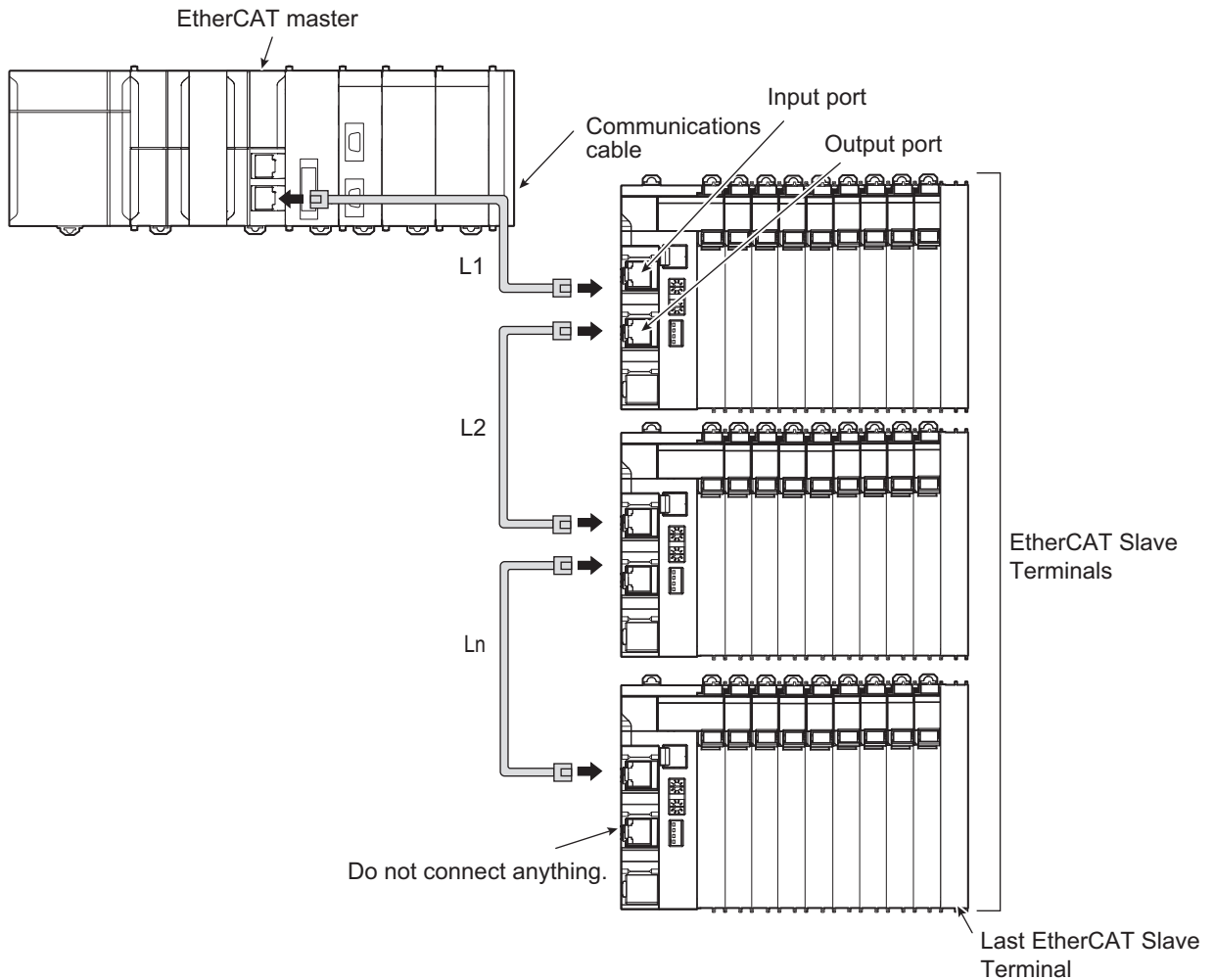

### Precautions for Correct Use

- The cable between any two nodes (L1, L2 ... Ln) must be 100 m or less.
- Firmly connect the communications cable connector until it clicks into place.
- When you install the communications cables, observe the cable specifications (e.g., bending radius) of the cable manufacturer.
- Do not disconnect the communications cables from the EtherCAT Slave Terminals during operation. The outputs from the EtherCAT master may become unstable. However, for the built-in EtherCAT port on an NJ/NX-series CPU Unit or NY-series Industrial PC, you can disconnect the communications cable from an EtherCAT Slave Terminal that has been disconnected from communications in the software.



### Additional Information

Make sure the cable between each pair of devices connects an output port to an input port. Normal communications are not possible if an output port is connected to another output port or an input port is connected to another input port.

## 7-2 Connecting the Power Supply and Ground Wires

This section describes how to wire the power supplies and ground the EtherCAT Slave Terminal.

### 7-2-1 Wiring the EtherCAT Coupler Unit

The wiring of the power supply and ground to the EtherCAT Coupler Unit is shown in the following figure.

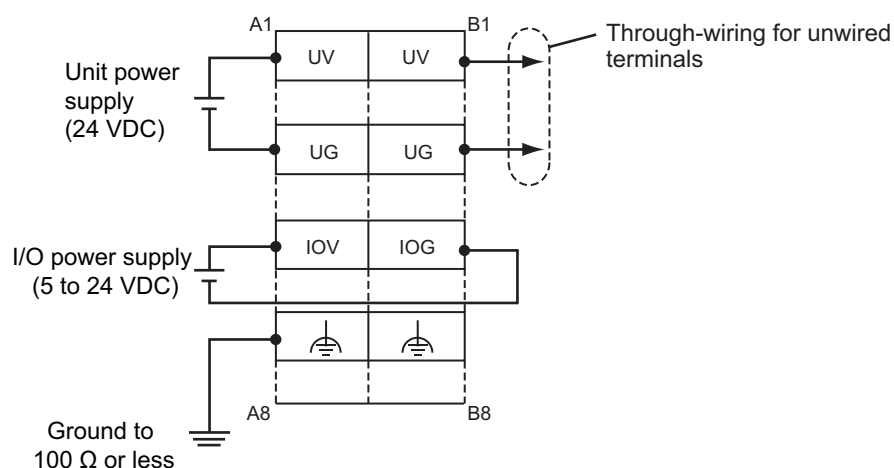

#### ● Unit Power Supply Terminals

These terminals are connected to the Unit power supply. The details are given in the following table.

Terminal number indication	Terminal name	Description
A1 or B1	UV	Connect the 24-VDC wire (positive side) from the Unit power supply to either the A1 or B1 terminal.
A3 or B3	UG	Connect the 0-VDC wire (negative side) from the Unit power supply to either the A3 or B3 terminal.

You can use the unwired terminals for through-wiring to an Additional NX Unit Power Supply Unit or to the Unit power supply terminals on another EtherCAT Coupler Unit. Make the current supplied from the unwired terminals meet the following conditions.

*Current supplied from unwired terminals  $\leq$  Current capacity of power supply terminals – Current consumption of the EtherCAT Coupler Unit block*

Refer to 5-4-1 *Selecting the Unit Power Supply* on page 5-16 for details on blocks.

#### ● I/O Power Supply Terminals

These terminals are connected to the I/O power supply. The details are given in the following table.

Terminal number indication	Terminal name	Description
A5	IOV	Connect the 5 to 24-VDC wire (positive side) from the I/O power supply.
B5	IOG	Connect the 0-VDC wire (negative side) from the I/O power supply.

Provide a power supply voltage that is within the power supply voltage specifications of the NX Unit I/O circuits and connected external devices.

### ● Functional Ground Terminals

These are the functional ground terminals. Connect the ground wire to one of these terminals. The details are given in the following table.

Terminal number indication	Terminal symbol	Description
A7 or B7		Connect the ground wire to either the A7 or B7 terminal.



#### Precautions for Correct Use

Do not connect the through-wiring terminals on the Unit power supply terminals to the I/O power supply terminals. Always use separate power supplies for the Unit power supply and the I/O power supply. Otherwise, noise may cause malfunctions.

Refer to *7-2-5 Wiring to the Screwless Clamping Terminal Block* on page 7-13 for the procedure to connect wires to the terminals on the screwless clamping terminal block.

## 7-2-2 Wiring the Power Supply to the EtherCAT Slave Terminal

Refer to *Section 5 Designing the Power Supply System* on page 5-1 for information on wiring the power supplies to the EtherCAT Slave Terminal.

## 7-2-3 Grounding the EtherCAT Slave Terminal

This section describes how to ground the EtherCAT Slave Terminal.

## Units with Ground Terminals and Type of Ground Terminals

Some of the Units in an EtherCAT Slave Terminal have ground terminals.

### ● Units with Ground Terminals

- EtherCAT Coupler Units
- Additional NX Unit Power Supply Unit
- Shield Connection Unit

When connecting NX Units to external devices, the Shield Connection Unit is used to connect the shield wire when the shield is used. You can ground more than one shield wire to the same

ground pole to reduce the amount of wiring work for grounding. For the specifications of the Shield Connection Unit, refer to the *NX-series System Units User's Manual (Cat. No. W523)*.

### ● Type of Ground Terminals

The ground terminals are functional ground terminals.



Functional grounding is done to protect device and system functions, including prevention of noise from external sources, or prevention of noise from devices or equipment that could have harmful effects on other devices or equipment.

## DIN Track Contact Plates

A Unit that has a ground terminal also has a DIN Track contact plate on the back of the Unit.

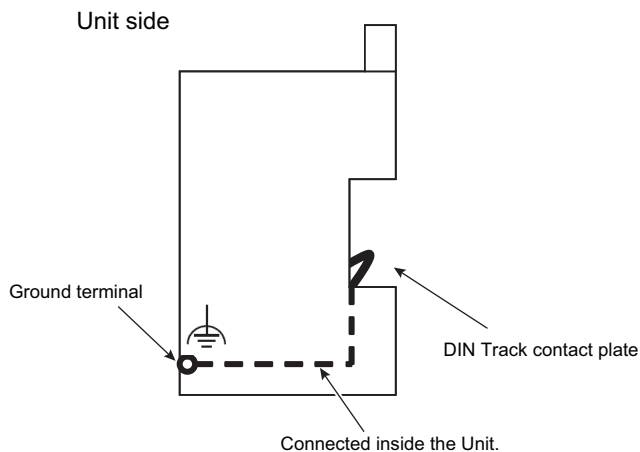

The DIN Track contact plate is connected internally to the ground terminal on the Unit.

This means that the ground terminal will be electrically connected to the DIN Track.

For information on the DIN Track contact plate on the EtherCAT Coupler Unit, refer to *4-6 DIN Track Contact Plate* on page 4-17. For information on the NX Units that have a ground terminal, refer to the *NX-series System Units User's Manual (Cat. No. W523)*.

## Grounding the EtherCAT Slave Terminal

This section describes how to ground the ground terminals on the EtherCAT Slave Terminal.

The functional ground terminals that are provided on some Units and the DIN Track are grounded.

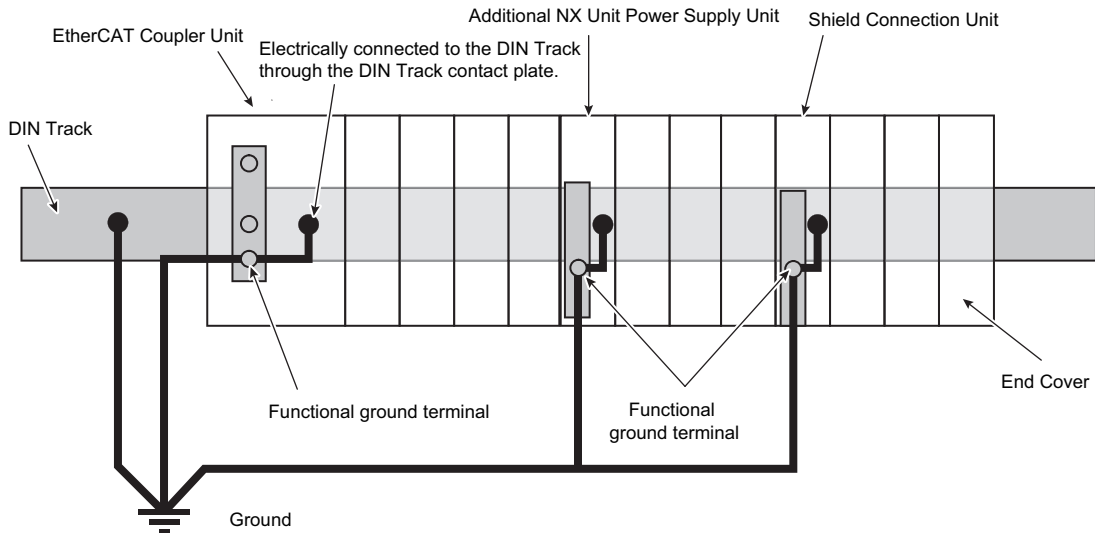

If the DIN Track is made of steel and the surface is not treated to produce an insulating material, you can omit grounding the functional ground terminal on any Unit that has one, as shown in the following figures.

■ DIN Track Made of Steel and Surface Not Insulated

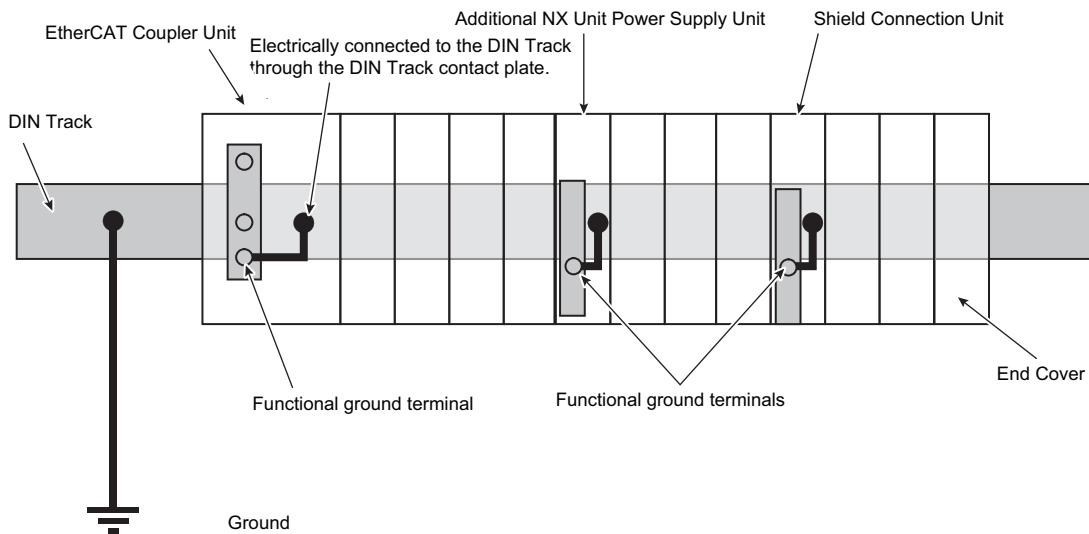

### Precautions for Correct Use

- Ground the ground terminals and DIN Track through dedicated ground wires to a ground resistance of  $100\ \Omega$  or less. The ground wire should not be more than 20 m long. Use a ground wire that is  $2.0\ \text{mm}^2$  or larger. Refer to *Applicable Wires* on page 7-13 for the applicable ground wires for screwless clamping terminal blocks.
- If the DIN Track is not made of steel or if the surface is treated to produce an insulating material\*1, always connect ground wires to the ground terminals. Otherwise, noise may cause malfunctions.

\*1. If the surface of the DIN Track is treated to produce an insulating material (e.g., anodized aluminum), the DIN Track contact plate will not be electrically connected to the DIN Track even if they are in physical contact.

## Grounding the DIN Track

Attach a crimped terminal to the ground wire and then connect it to mounting hole on the DIN Track with a screw to ground the DIN Track.

## Grounding the EtherCAT Slave Terminal with Peripheral Devices and in Control Panels

Refer to 6-2-6 *Grounding* on page 6-31 for the grounding procedures for the EtherCAT Slave Terminal with peripheral devices and in control panels.

## Isolating the EtherCAT Slave Terminal from the Control Panel

If the ground wire for the EtherCAT Coupler Unit or an NX Unit with a ground terminal is shared with power equipment, noise will adversely affect the Units.

You can use OMRON NX-AUX01 DIN Track Insulation Spacers with PFP-50N or PFP-100N DIN Tracks to isolate an EtherCAT Slave Terminal from the control panel.

### ● Installing DIN Track Insulation Spacers and DIN Track

Secure the DIN Track Insulation Spacers to the control panel with screws, and then secure the DIN Track to the DIN Track Insulation Spacers. The recommended tightening torque for M4 screws is 1.2 N·m.

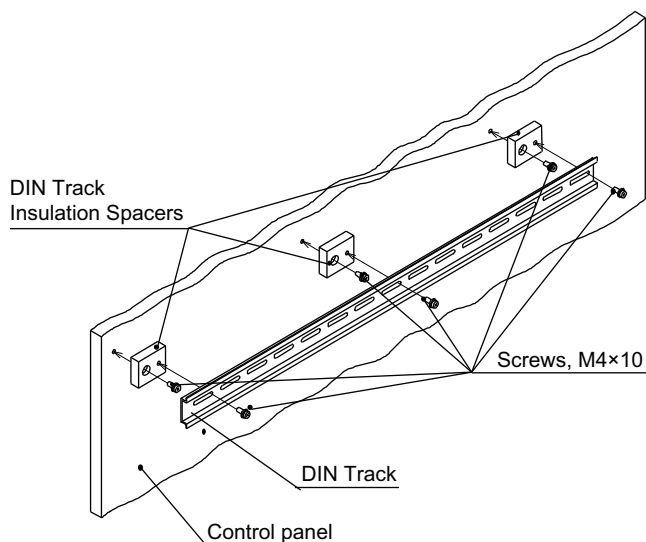

- DIN Track Insulation Spacers  
NX-AUX01 (OMRON Corporation)  
Three Spacers are included in one model.

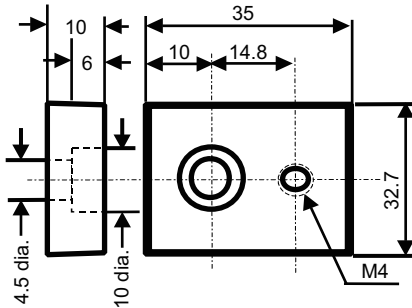

### Precautions for Correct Use

If you use DIN Track Insulation Spacers to install an EtherCAT Slave Terminal, the height will be increased by approximately 10 mm. Make sure that the EtherCAT Slave Terminal and connecting cables do not come into contact with other devices.

## 7-2-4 Precautions for Wiring the EtherCAT Slave Terminal Together with Computers and Other Peripheral Devices

### ⚠ CAUTION

When you connect a computer or other peripheral device to the following Unit, either ground the 0-V side of the external power supply (i.e. Unit power supply) or do not ground it at all.

- EtherCAT Coupler Unit with a non-isolated DC power supply (internal power supply circuits)

Depending on how the peripheral device is grounded, the external power supply (i.e. Unit power supply) may be shorted. Never ground the 24-V side of the power supply, as shown in the following figure.

Grounding That Causes a 24-V Power Supply to Short

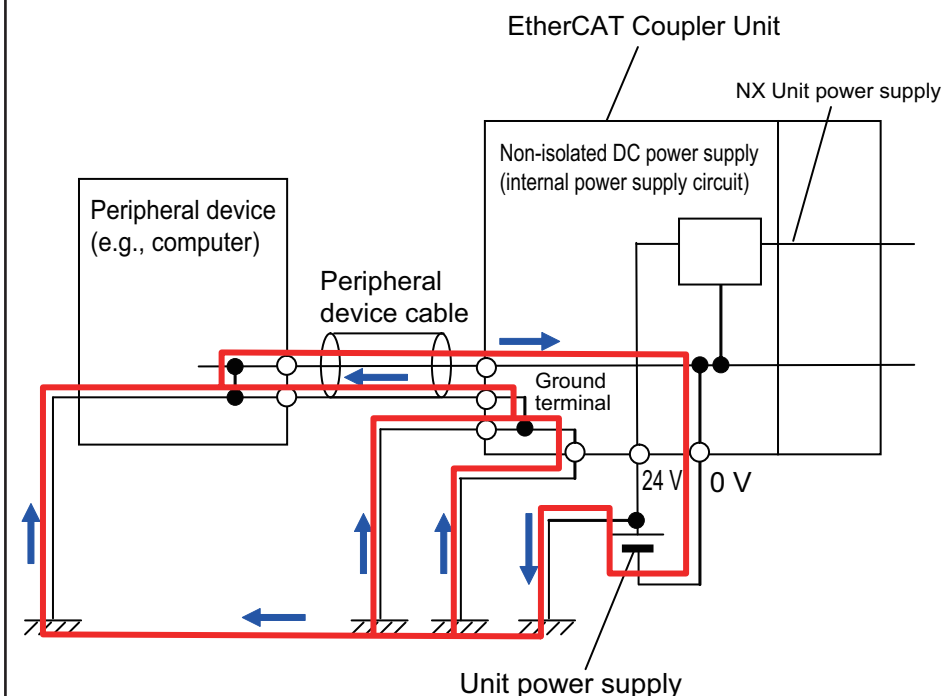

## 7-2-5 Wiring to the Screwless Clamping Terminal Block

This section describes how to connect wires to the screwless clamping terminal block on the EtherCAT Coupler Unit, the installation and removing methods, and functions for preventing incorrect attachment.

You can connect ferrules that are attached to the twisted wires to the screwless clamping terminal block. You can also connect the twisted wires or the solid wires to the screwless clamping terminal block. If you connect the ferrules, all you need to do to connect the wires is to insert the ferrules into the terminal holes.

### ⚠ WARNING

Make sure that the voltages and currents that are input to the Units and slaves are within the specified ranges.  
Inputting voltages or currents that are outside of the specified ranges may cause failure or fire.

## Applicable Wires

You can connect twisted wires, solid wires, or ferrules attached to twisted wires to the screwless clamping terminal block. The applicable wire dimensions and preparation methods are given below.

### ● Dimensions of Wires Connected to the Terminal Block

The dimensions of wires that you can connect into the terminal holes of the screwless clamping terminal block are as in the figure below.

Process the applicable wires that are specified in the following description to apply the dimensions.

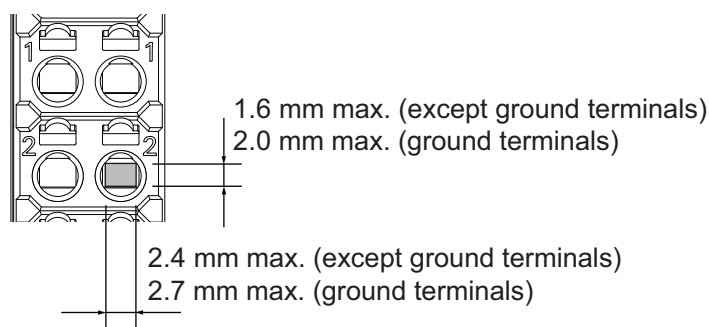

### ● Using Ferrules

If you use ferrules, attach the twisted wires to them.

Observe the application instructions for your ferrules for the wire stripping length when attaching ferrules.

Always use plated one-pin ferrules. Do not use unplated ferrules or two-pin ferrules.

The applicable ferrules, wires, and crimping tools are given in the following table.

Terminal type	Manufacturer	Ferrule model	Applicable wire (mm <sup>2</sup> (AWG))	Crimping tool
All terminals except ground terminals	Phoenix Contact	AI0,34-8	0.34 (#22)	Phoenix Contact (Applicable wire sizes are given in parentheses.) CRIMPFOX 6 (0.25 to 6 mm <sup>2</sup> , AWG24 to 10)
		AI0,5-8	0.5 (#20)	
		AI0,5-10		
		AI0,75-8	0.75 (#18)	
		AI0,75-10		
		AI1,0-8	1.0 (#18)	
		AI1,0-10		
		AI1,5-8	1.5 (#16)	
		AI1,5-10		
Ground terminals		AI2,5-10	2.0*1	
All terminals except ground terminals	Weidmuller	H0.14/12	0.14 (#26)	Weidmuller (Applicable wire sizes are given in parentheses.) PZ6 Roto (0.14 to 6 mm <sup>2</sup> , AWG26 to 10)
		H0.25/12	0.25 (#24)	
		H0.34/12	0.34 (#22)	
		H0.5/14	0.5 (#20)	
		H0.5/16		
		H0.75/14	0.75 (#18)	
		H0.75/16		
		H1.0/14	1.0 (#18)	
		H1.0/16		
		H1.5/14	1.5 (#16)	
		H1.5/16		

\*1. For the ferrule type AI2,5-10, use wires with a diameter of 2.0 to 2.1 mm<sup>2</sup>. Wires with a diameter exceeding 2.1 mm<sup>2</sup> cannot be used with the screwless clamping terminal block.

When you use any ferrules other than those in the above table, crimp them to the twisted wires so that the following processed dimensions are achieved.

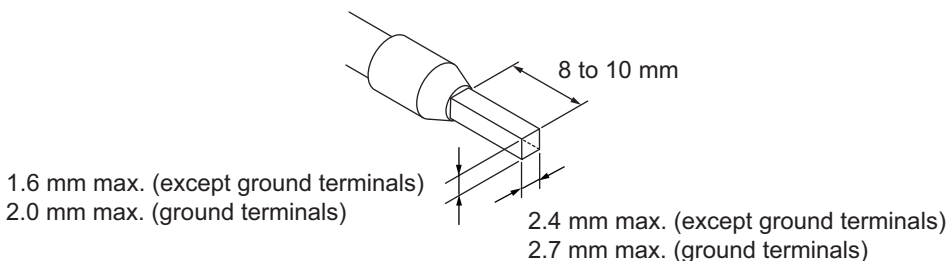

### ● Using Twisted Wires/Solid Wires

If you use twisted wires or solid wires, use the following table to determine the correct wire specifications.

Terminals		Wire type				Wire size	Conductor length (stripping length)
		Twisted wires		Solid wires			
Classification	Current capacity	Plated	Unplated	Plated	Unplated		
All terminals except ground terminals	2 A max.	Possible	Possible	Possible	Possible	0.08 to 1.5 mm <sup>2</sup> (AWG28 to 16)	8 to 10 mm
	Greater than 2 A and 4 A or less		Not possible	Possible*1	Not possible		
	Greater than 4 A	Possible*1		Not possible			
Ground terminals	---	Possible	Possible	Possible*2	Possible*2	2.0 mm <sup>2</sup>	9 to 10 mm

\*1. Secure wires to the screwless clamping terminal block. Refer to *Securing Wires* on page 7-18 for how to secure wires.

\*2. With the NX-TB□□□1 Terminal Block, use twisted wires to connect the ground terminal. Do not use a solid wire.

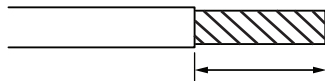

Conductor length (stripping length)



**Precautions for Correct Use**

- Use cables with suitable wire sizes for the carrying current. There are also restrictions on the current due to the ambient temperature. Refer to the manuals for the cables and use the cables correctly for the operating environment.
- For twisted wires, strip the sheath and twist the conductor portion. Do not unravel or bend the conductor portion of twisted wires or solid wires.

NG

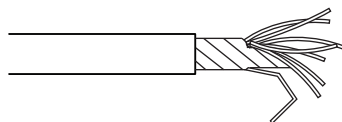

Unravel wires

NG

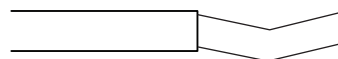

Bend wires



**Additional Information**

If more than 2 A will flow on the wires, use plated wires or use ferrules.

**Connecting and Removing Wires**

This section describes how to connect and remove wires.

## ● Terminal Block Parts and Names

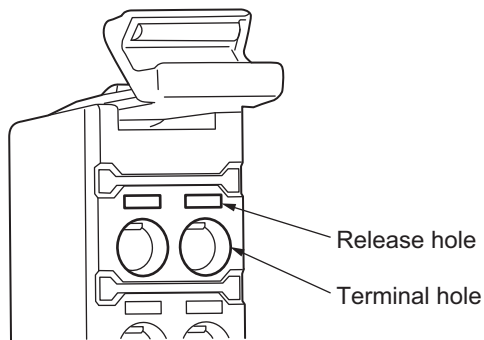

## ● Required Tools

Use a flat-blade screwdriver to connect and remove wires.

Use the following flat-blade screwdriver.

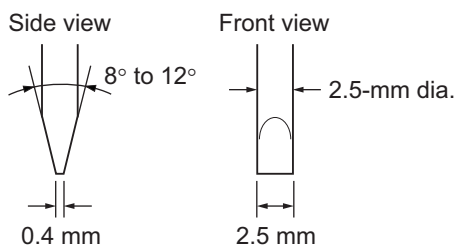

Recommended screwdriver

Model	Manufacturer
SZF 0-0,4X2,5	Phoenix Contact

## ● Connecting Ferrules

Insert the ferrule straight into the terminal hole.

You do not need to insert a flat-blade screwdriver into the release hole.

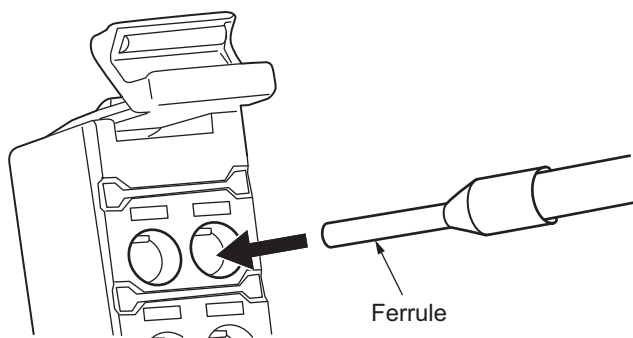

After you make a connection, make sure that the ferrule is securely connected to the terminal block.

## ● Connecting Twisted Wires or Solid Wires

Use the following procedure to connect the twisted wires or solid wires to the terminal block.

- 1 Press a flat-blade screwdriver diagonally into the release hole.  
The optimal angle for insertion is between  $10^{\circ}$  to  $15^{\circ}$ . If the screwdriver is inserted correctly, you should feel resistance from the spring inside the release hole.

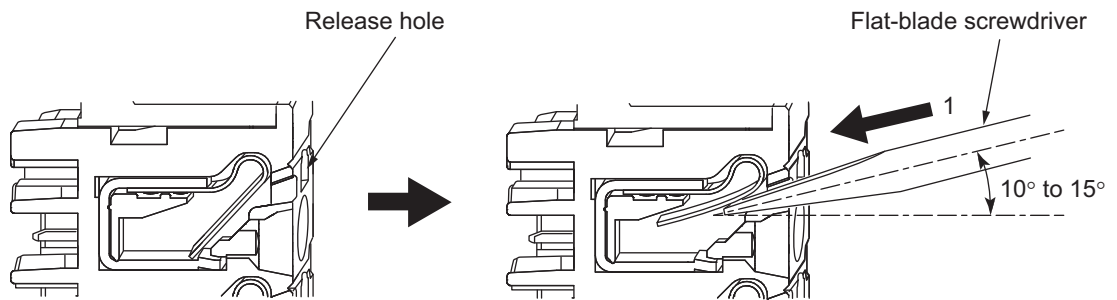

- 2 Leave the flat-blade screwdriver pressed into the release hole and insert the twisted wire or the solid wire into the terminal hole.  
Insert the stripped portion of the wire all the way into the terminal hole to prevent shorting.

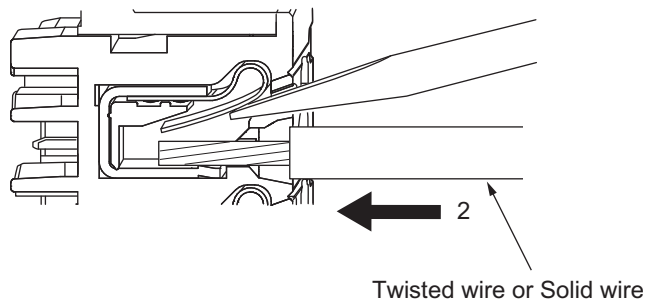

- 3 Remove the flat-blade screwdriver from the release hole.

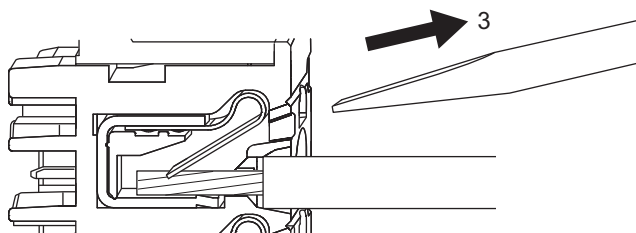

After you make a connection, lightly pull the twisted wire or the solid wire to make sure that the wire is securely connected to the terminal block.



### Precautions for Safe Use

- Do not press the flat-blade screwdriver straight into the release holes on a screwless clamping terminal block. Doing so may damage the terminal block.

**NG**

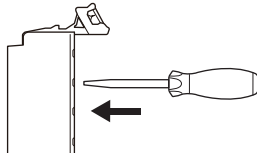

**OK**

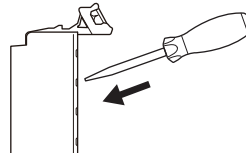

- When you insert a flat-blade screwdriver into a release hole on a screwless clamping terminal block, press it down with a force of 30N or less. Applying excessive force may damage the terminal block.
- Do not incline or twist the flat-blade screwdriver while it is in a release hole on a screwless clamping terminal block. Doing so may damage the terminal block.

**NG**

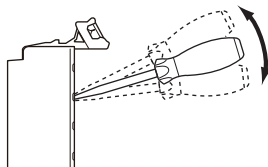

**NG**

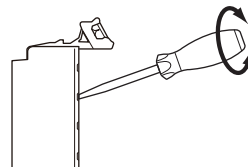

- Make sure that all wiring is correct.
- Do not bend the cable forcibly. Doing so may break the cables.

### ● Securing Wires

It is necessary to secure wires to the screwless clamping terminal block depending on the wire types that are used or the current flows on the wires.

The following table gives the necessity for securing wires.

Terminals		Wire type				
Classifica- tion	Current ca- pacity	Ferrule	Twisted wires		Solid wires	
			Plated	Unplated	Plated	Unplated
All terminals except ground termi- nals	2 A max.	No	No	No	No	No
	Greater than 2 A and 4 A or less			Yes	Not possible	Yes
			Greater than 4 A			
Ground termi- nals	---		No	No	No	No

Use the following procedure to secure the wires.

#### 1 Prepare a cable tie.

A cable tie can be used with a width of 4 mm or less and a thickness of 1.5 mm or less. Select a cable tie correctly for the operating environment.

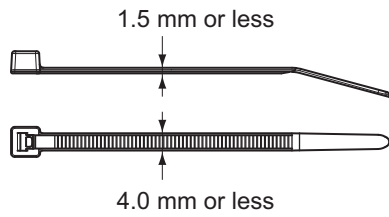

- 2** Pass a cable tie through the hole for securing wires on the bottom of the screwless clamping terminal block.

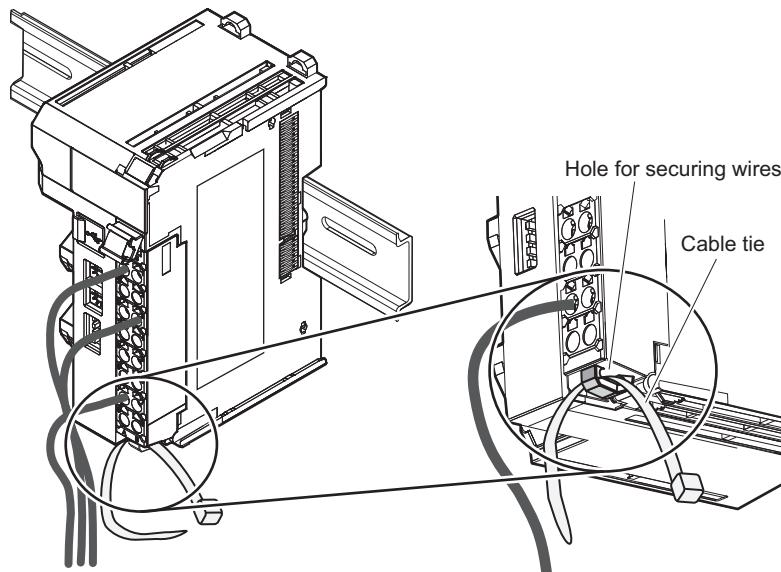

- 3** Bundle the wires with a cable tie and secure them to the screwless clamping terminal block.

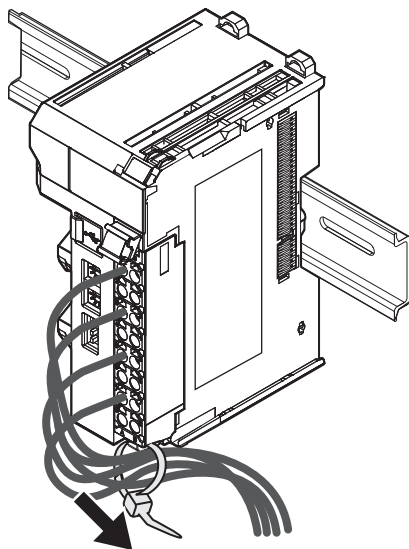

Secure wires within the range of 30 mm from the screwless clamping terminal block.

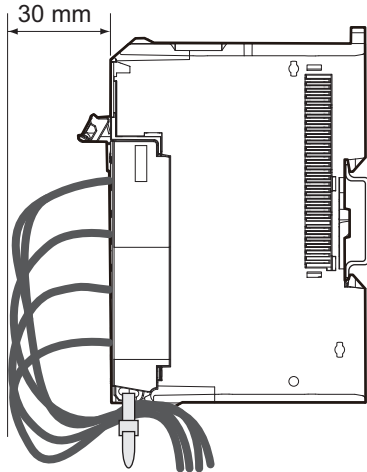

## ● Removing Wires

Use the following procedure to remove the wires from the terminal block. The removal method is the same for ferrules, twisted wires, and solid wires.

If wires are secured firmly to the terminal block, release them first.

- 1** Press the flat-blade screwdriver diagonally into the release hole. The optimal angle for insertion is between  $10^\circ$  to  $15^\circ$ . If the screwdriver is inserted correctly, you should feel resistance from the spring inside the release hole.

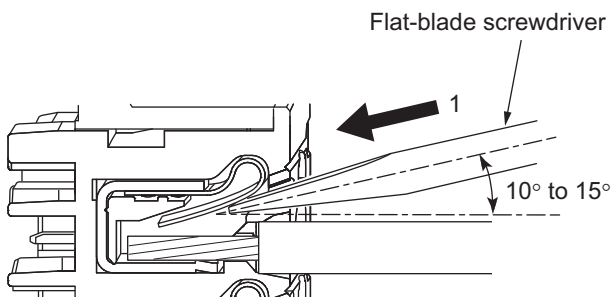

- 2** Insert the flat-blade screwdriver into the release hole and remove the wire from the terminal hole.

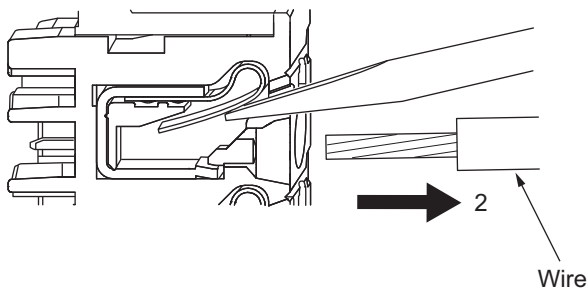

- 3** Remove the flat-blade screwdriver from the release hole.

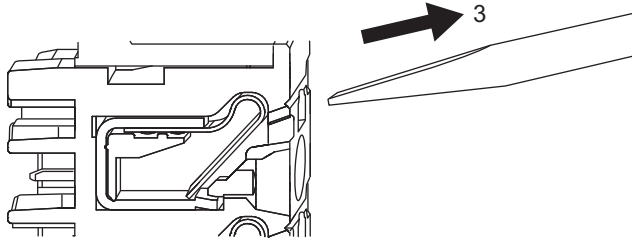

### Precautions for Safe Use

- Do not press the flat-blade screwdriver straight into the release holes on a screwless clamping terminal block. Doing so may damage the terminal block.

**NG**

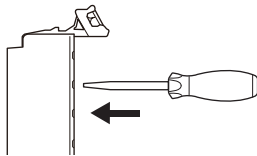

**OK**

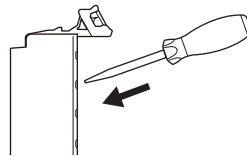

- When you insert a flat-blade screwdriver into a release hole on a screwless clamping terminal block, press it down with a force of 30N or less. Applying excessive force may damage the terminal block.
- Do not incline or twist the flat-blade screwdriver while it is in a release hole on a screwless clamping terminal block. Doing so may damage the terminal block.

**NG**

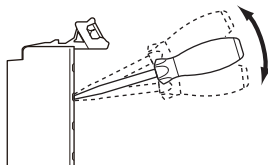

**NG**

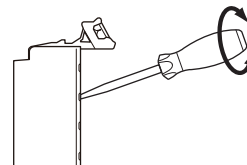

- Make sure that all wiring is correct.
- Do not bend the cable forcibly. Doing so may break the cables.

## Removing a Terminal Block

- Press the lock lever on the terminal block and pull out the top of the terminal block to remove it.

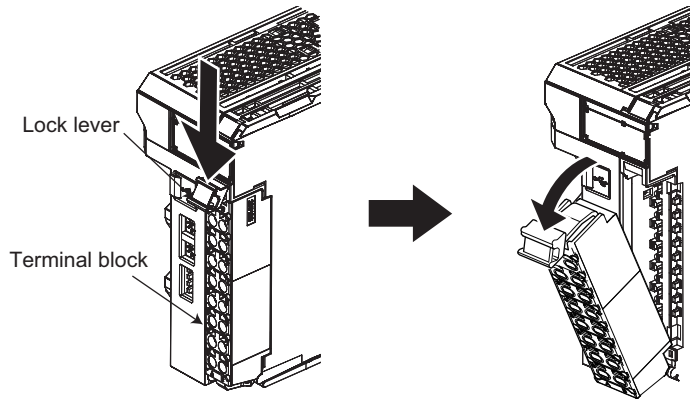

## Attaching a Terminal Block

- 1 Mount the terminal block hook on the guide at the bottom of the EtherCAT Coupler Unit, lift up the terminal block, and press in on the top of the terminal block until you hear it engage. The terminal block will click into place on the Unit. After you mount the terminal block, make sure that it is locked to the Unit.

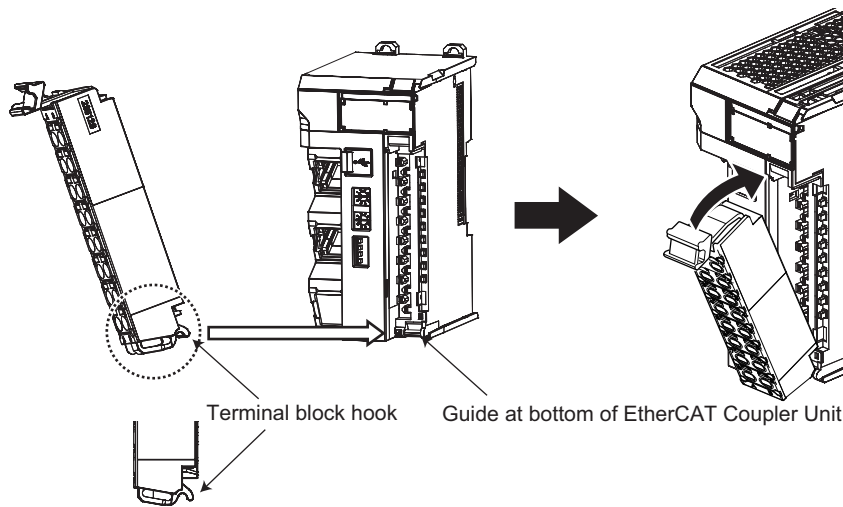

Mount a terminal block that is applicable to the model of the EtherCAT Coupler Unit. Refer to *4-5 Terminal Blocks* on page 4-15 for the applicable terminal blocks.

## Preventing Incorrect Attachment of Terminal Blocks

In order to prevent unintentionally installing the wrong terminal block, you can limit the combination of a Unit and a terminal block.

Insert three Coding Pins (NX-AUX02) into three of the six incorrect attachment prevention holes on the Unit and on the terminal block. Insert these pins into positions so that they do not interfere with each other when the Unit and terminal block are connected to each other.

You can use these pins to create a combination in which the wrong terminal block cannot be attached because the pin patterns do not match.

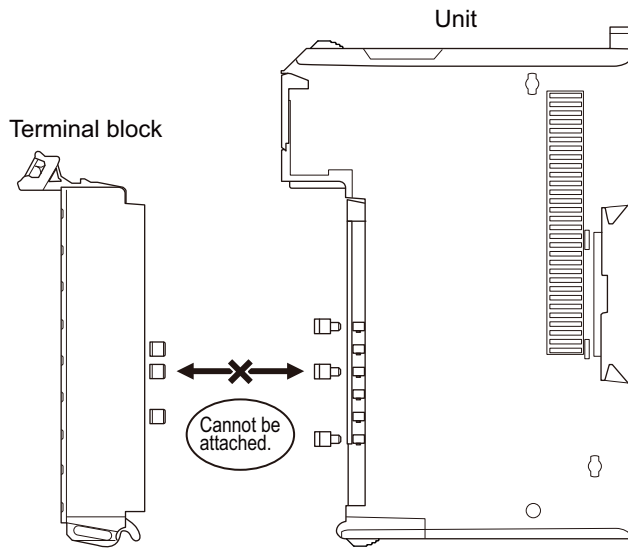

### ● Types of Coding Pins

There are two types of Coding Pins, both with their own unique shape: one for terminal blocks and one for Units.

Three pins come with each runner.

For terminal block

For Unit

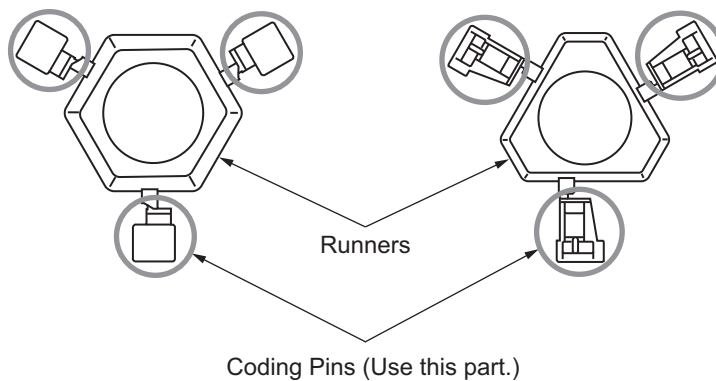

Use the following Coding Pins.

Name	Model	Specification
Coding Pin	NX-AUX02	For 10 Units (Terminal block: 30 pins, Unit: 30 pins)

### ● Insertion Locations and Patterns of Coding Pins

Insert three Coding Pins each on the terminal block and on the Unit at the positions designated by the numbers 1 through 6 in the figure below.

As shown in the following table, there are 20 unique pin patterns that you can use.

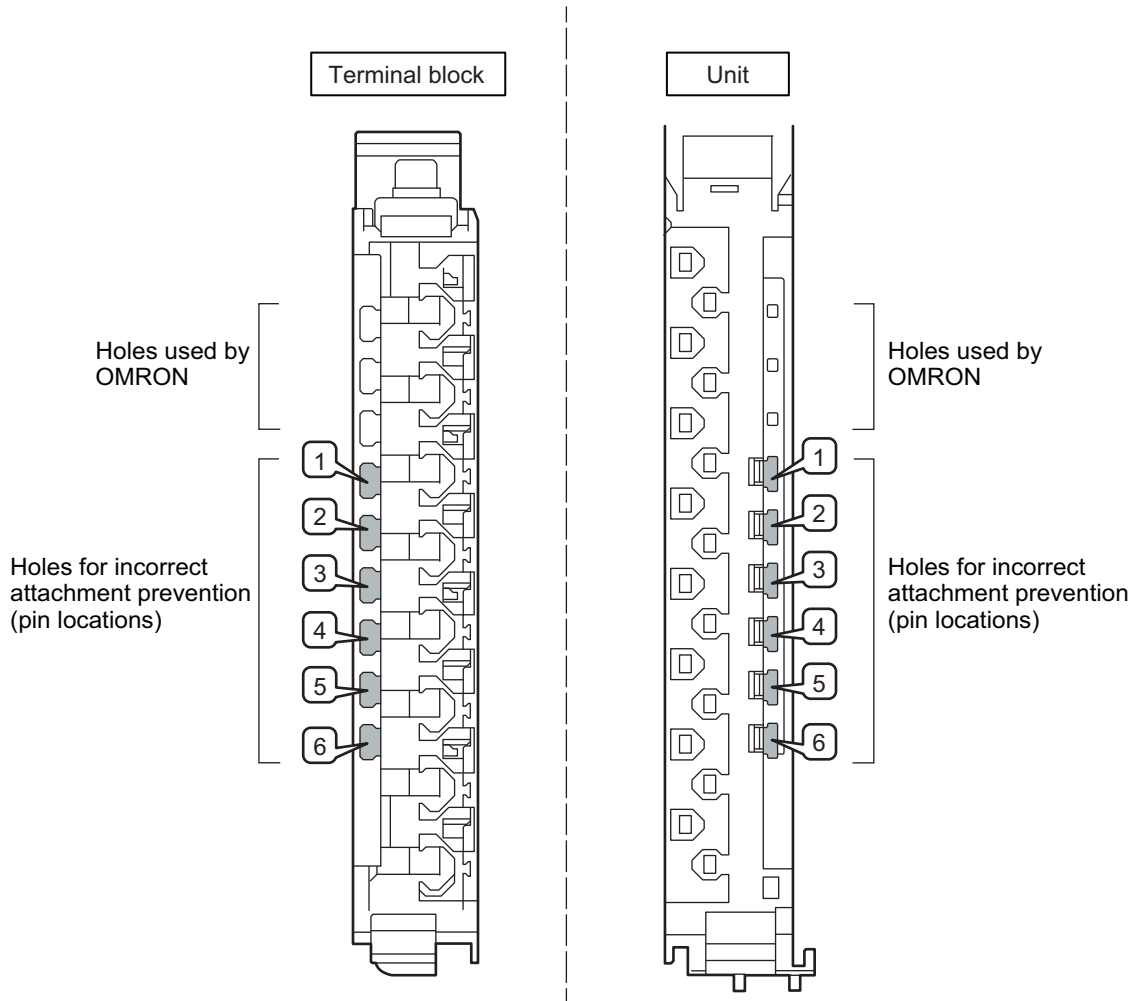

○: Pin inserted

Pattern	Pin locations for terminal block						Pin locations for Unit					
	1	2	3	4	5	6	1	2	3	4	5	6
No.1	○	○	○							○	○	○
No.2	○	○		○					○		○	○
No.3	○	○			○				○	○		○
No.4	○	○				○			○	○	○	
No.5	○		○	○				○			○	○
No.6	○		○		○			○		○		○
No.7	○		○			○		○		○	○	
No.8	○			○	○			○	○			○
No.9	○			○		○		○	○		○	
No.10	○				○	○		○	○	○		
No.11		○	○	○			○				○	○
No.12		○	○		○		○			○		○
No.13		○	○			○	○			○	○	
No.14		○		○	○		○		○			○
No.15		○		○		○	○		○		○	
No.16		○			○	○	○		○	○		
No.17			○	○	○		○	○				○
No.18			○	○		○	○	○			○	
No.19			○		○	○	○	○		○		
No.20				○	○	○	○	○	○			

Two sets of NX-AUX02 Pins are required to make the maximum of 20 pin patterns. (One set for 10 Units.)



### Precautions for Correct Use

- The holes not designated by the numbers 1 through 6 in the above figure are used by OMRON. If you insert any Coding Pins into the holes reserved for use by OMRON, you will not be able to mount the terminal block to the Unit.
- Do not use Coding Pins that have been attached and removed.

### ● Inserting the Coding Pins

- 1 Hold the pins by the runner and insert a pin into one of the incorrect attachment prevention holes on the terminal block or on the Unit.

Terminal block

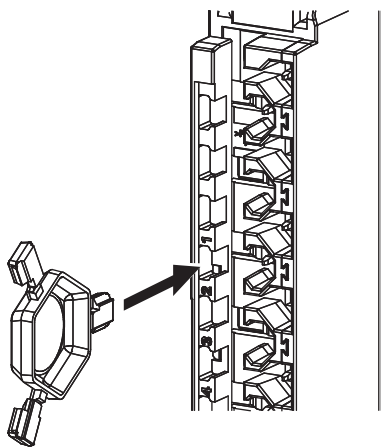

Unit

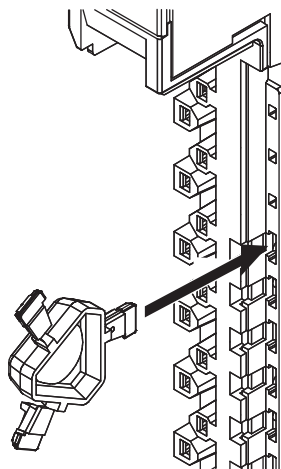

- 2 Rotate the runner to break off the Coding Pin.

Terminal block

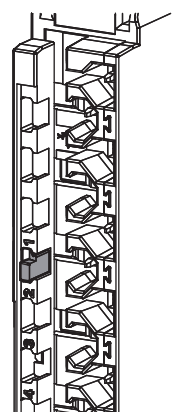
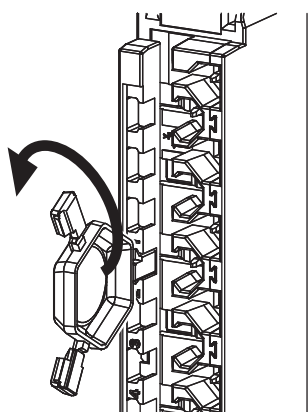

Unit

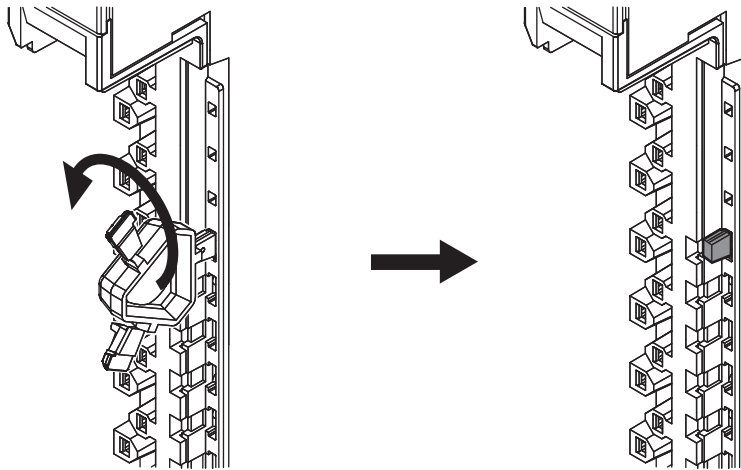

## 7-3 Connecting USB Cable

The EtherCAT Coupler Unit can be connected directly to a computer in which the Sysmac Studio is installed through a USB cable.

### Connection Method

Use a commercially available USB certified cable to connect the computer in which the Sysmac Studio is installed to the peripheral USB port on the EtherCAT Coupler Unit.

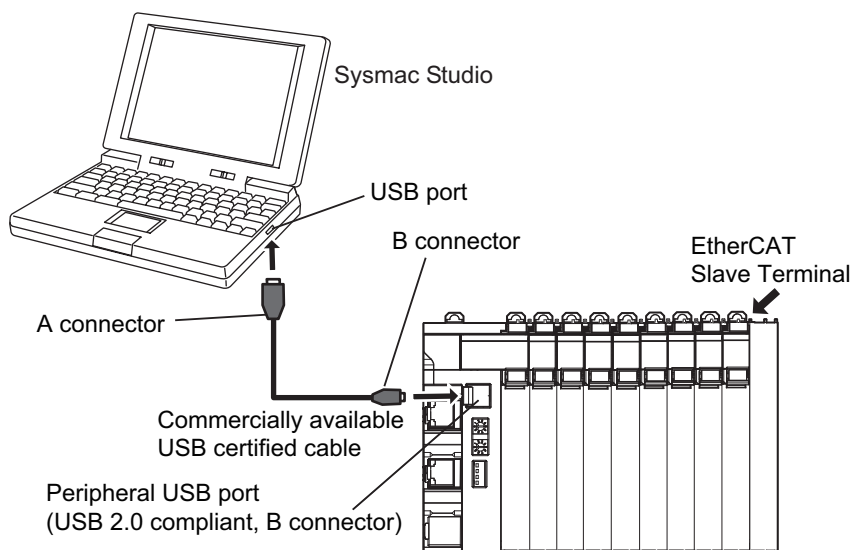

### Connecting Cable

Use the following cable to connect the EtherCAT Coupler Unit and the computer in which the Sysmac Studio is installed.

Unit port	Computer port	Network type (communications mode)	Model	Length
Peripheral USB port (USB 2.0 compliant, B connector)	USB port	USB 2.0	Commercially available USB certified cable (A connector and B connector)	5 m max.

### Preparations

To connect the EtherCAT Coupler Unit to a computer with USB, you must first install a USB driver in the computer.

When you install the Sysmac Studio, a USB driver for a USB connection will be automatically installed in the computer.

When you turn ON the Unit power supply to the EtherCAT Slave Terminal and connect the EtherCAT Coupler Unit and computer with a USB cable, the computer will automatically recognize the device and start installing the USB driver.

Refer to the *Sysmac Studio Version 1 Operation Manual (Cat. No. W504)* for the installation procedure for the USB driver.

## Setting Up With the Sysmac Studio

---

The connection between the EtherCAT Coupler Unit and computer is set up with the Sysmac Studio. Refer to *2-3-2 Connection Method and Procedures* on page 2-10 for the procedure to connect to the Sysmac Studio.

## Restrictions for USB Connections

---

When you connect the computer to the EtherCAT Coupler Unit, the USB specifications impose the following restrictions.

- You can connect only one computer to only one EtherCAT Coupler Unit with a USB connection. You cannot connect more than one of each at the same time.
- Do not disconnect the USB cable while the Sysmac Studio is online with the EtherCAT Coupler Unit. Always place the Sysmac Studio offline before you disconnect the USB cable.

## 7-4 Wiring External Signal Lines

---

Refer to the sections on wiring in the user's manuals for individual NX Units for information on wiring the external I/O signal lines between the external devices and the NX Units.

For precautions on wiring in control panels, refer to *6-2 Control Panel Installation* on page 6-24.



# 8

## EtherCAT Communications

This section provides an introduction to EtherCAT communications.

---

<b>8-1</b>	<b>Structure of CAN Application Protocol over EtherCAT (CoE)</b> .....	<b>8-2</b>
<b>8-2</b>	<b>EtherCAT Slave Information Files (ESI Files)</b> .....	<b>8-3</b>
<b>8-3</b>	<b>Transitions of Communications States</b> .....	<b>8-4</b>
<b>8-4</b>	<b>Process Data Objects (PDOs)</b> .....	<b>8-5</b>
8-4-1	Introduction .....	8-5
8-4-2	PDO Mappings .....	8-6
8-4-3	Assigning PDOs .....	8-8
<b>8-5</b>	<b>Service Data Objects (SDOs)</b> .....	<b>8-9</b>
8-5-1	Introduction .....	8-9
8-5-2	Abort Codes .....	8-9
<b>8-6</b>	<b>Communications between an EtherCAT Master and Slaves</b> .....	<b>8-10</b>
8-6-1	Communications Modes for Communications between an EtherCAT Master and Slaves .....	8-10
8-6-2	Communications Modes for EtherCAT Slave Terminals .....	8-10
8-6-3	Communications Cycle .....	8-10

## 8-1 Structure of CAN Application Protocol over EtherCAT (CoE)

EtherCAT allows the use of multiple protocols for communications. However, the EtherCAT Slave Terminal uses the *CAN application protocol over EtherCAT (CoE)* as the device profile for the *CAN application protocol*. The CoE is a communications interface that is designed to provide compatibility with EtherCAT devices. The CAN application protocol is an open network standard. The following figure shows how the CoE is structured for an EtherCAT Coupler Unit.

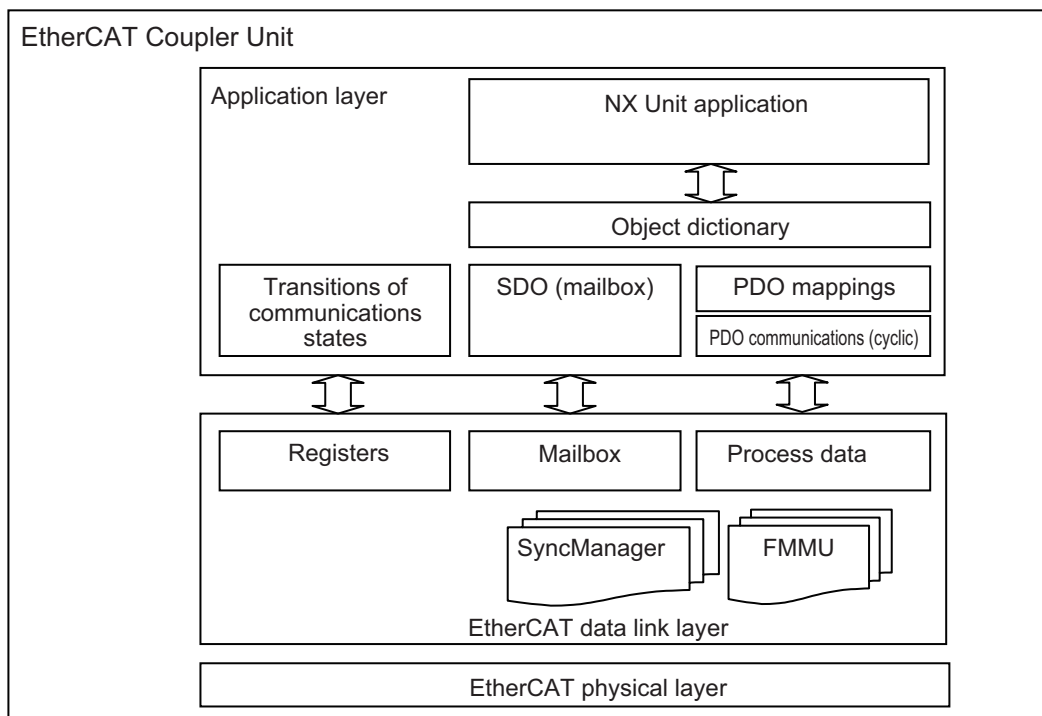

The object dictionary for the CAN application protocol is broadly divided into PDOs (process data objects) and SDOs (service data objects).

PDOs are contained in the object dictionary. The PDOs can be mapped in the object dictionary. The process data is defined by the PDO mappings. PDOs are used in PDO communications for periodic exchange of process data.

SDOs are the objects that can be read and written. SDOs are used in non-periodic SDO communications (event-driven message communications).

If you use the CoE interface to set the object dictionary for PDOs and SDOs, you can provide EtherCAT devices with the same device profiles as the CAN application protocol.

## 8-2 EtherCAT Slave Information Files (ESI Files)

The setting information for an EtherCAT slave is provided in an ESI file (EtherCAT slave information). The EtherCAT communications settings are defined based on the ESI files of the connected slaves and the network connection information.

You can create the network configuration information by installing ESI files into the network setup software (configuration tool).<sup>\*1</sup>

You can download the network configuration information to the EtherCAT master to configure the EtherCAT network.

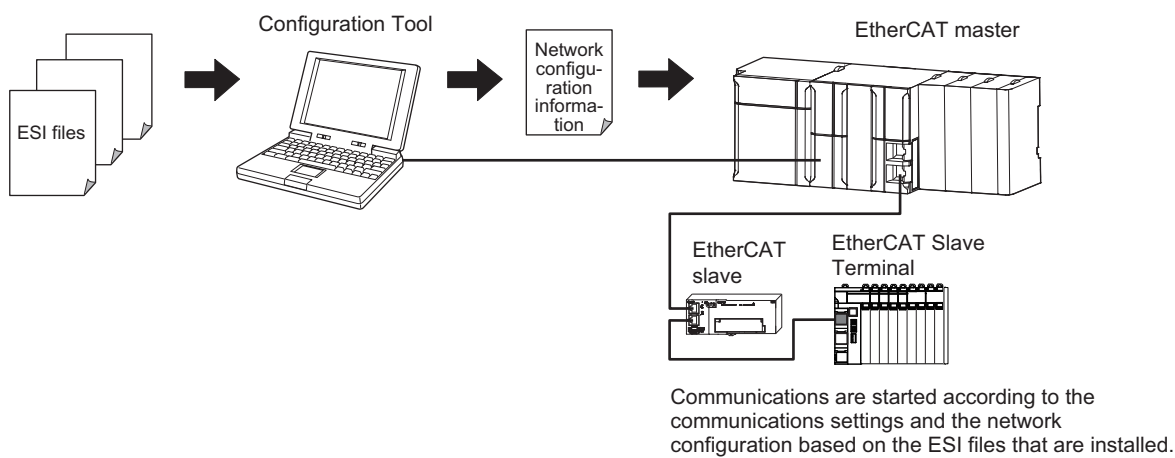

ESI files for the EtherCAT Coupler Unit and NX Units can be downloaded from the OMRON website.

\*1. Installation of the ESI files is not necessary if you are using the Sysmac Studio. The ESI files for OMRON EtherCAT slaves are already installed in the Sysmac Studio. You can update the Sysmac Studio to get the ESI files for the most recent models.

## 8-3 Transitions of Communications States

The state transition model for communications control of the EtherCAT Slave Terminals is controlled by the EtherCAT master.

The following figure shows the communications state transitions from when the power supply is turned ON.

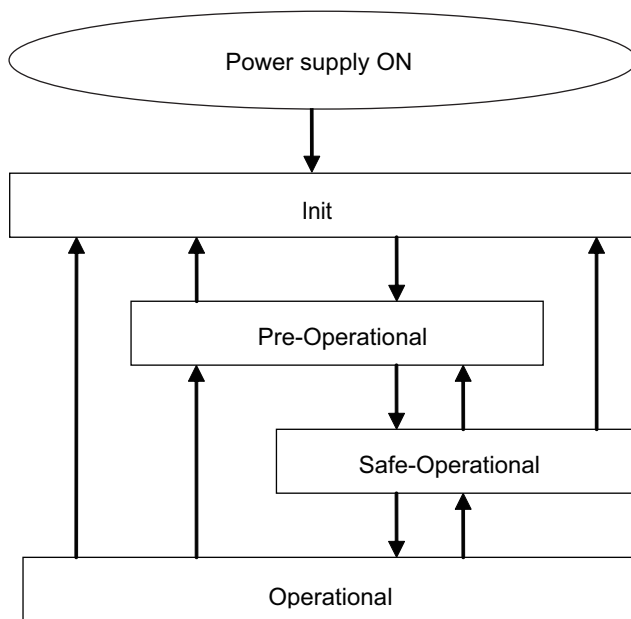

Status	SDO communications	Sending PDOs	Receiving PDOs	Description
Init	Not possible.	Not possible.	Not possible.	Communications are being initialized. Communications are not possible.
Pre-Operational	Possible.	Not possible.	Not possible.	Only SDO communications (message communications) are possible in this state. This state is entered after initialization is completed. It is used to initialize network settings.
Safe-Operational	Possible.	Possible.	Not possible.	In this state, both SDO communications (message communications) and sending PDOs are possible. Information, such as status, is sent from the Slave Terminal.
Operational	Possible.	Possible.	Possible.	This is the normal state for communications. PDO communications are used to control the I/O data.

## 8-4 Process Data Objects (PDOs)

### 8-4-1 Introduction

Process data objects (PDOs) are used to transfer data during cyclic communications in realtime.

There are two types of process data objects (PDOs): the RxPDOs, which are used by the EtherCAT Slave Terminal to receive data from the EtherCAT master; and the TxPDOs, which are used by the EtherCAT Slave Terminal to send data to the EtherCAT master.

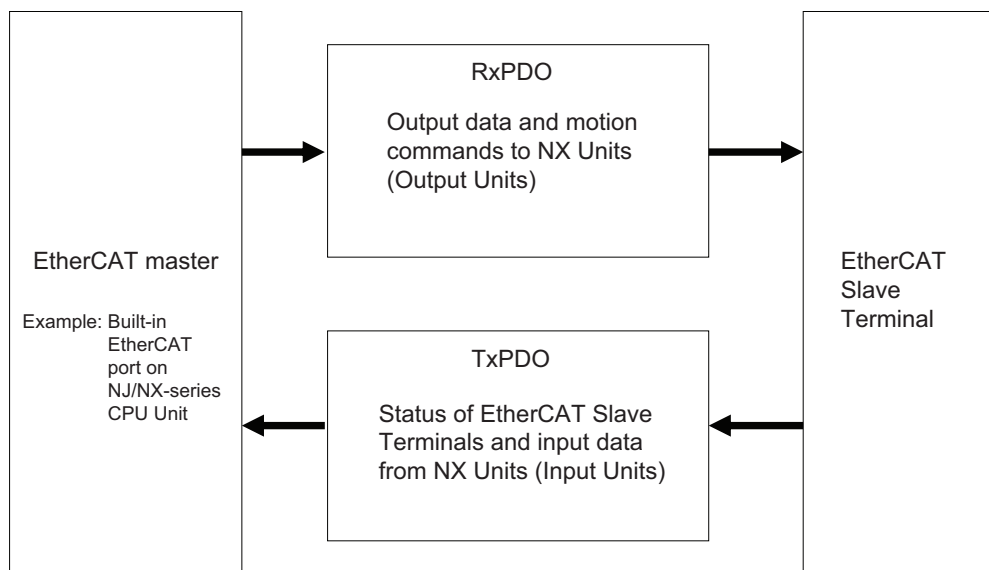

The EtherCAT application layer can hold more than one object to enable the transfer of various process data of the EtherCAT Slave Terminal.

The contents of the process data is defined in the *PDO mapping objects*.

EtherCAT Slave Terminals support PDO mapping for I/O control.

## 8-4-2 PDO Mappings

PDO mapping objects contain the I/O data for the EtherCAT Slave Terminals. PDO mapping objects for the RxPDOs are managed in the object dictionary from indexes 1600 to 17FF hex, and for the TxPDOs from indexes 1A00 to 1BFF hex.

### PDO Mapping Scheme in EtherCAT

The PDO mapping scheme in EtherCAT is described below.

Three application objects (objects A, B, and D) are allocated to the PDO (name: PDO\_1) at index 1ZZZ hex.

As described here, PDO mapping shows how application objects are assigned to PDOs. Indexes and subindexes are also assigned to application objects.

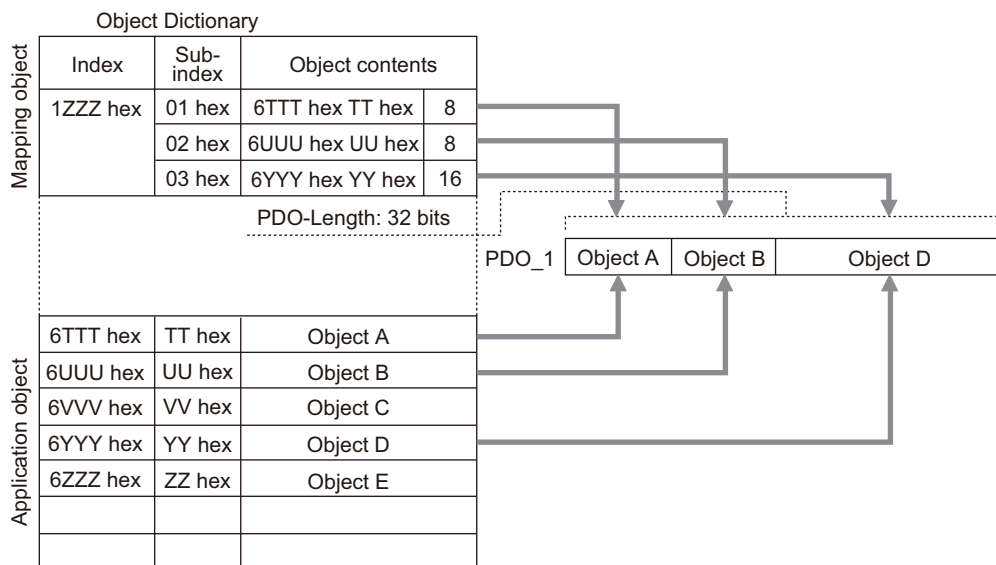

### PDO Mapping with EtherCAT Slave Terminals

An EtherCAT Slave Terminal has PDOs for the EtherCAT Coupler Unit and each NX Unit. Application objects are assigned by default to the PDOs for each Unit.

The following diagram shows a specific example for one of the PDOs in an EtherCAT Coupler Unit.

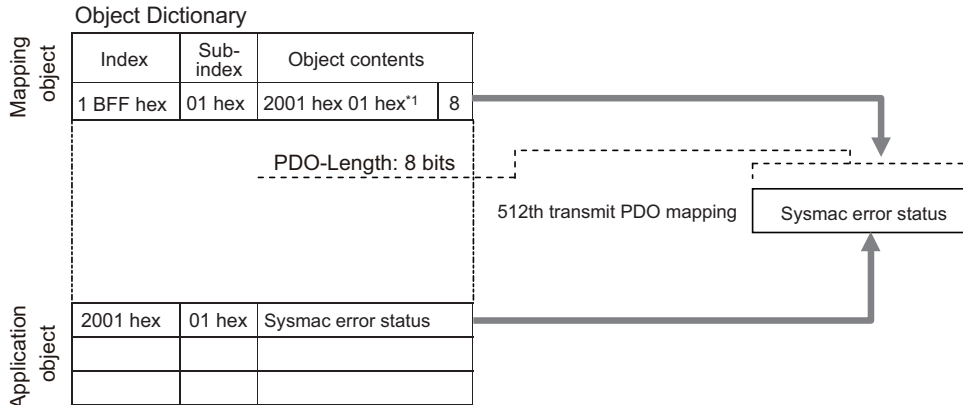

\*1. This is expressed as 0x2001:01 on the Sysmac Studio.

In the previous example, a single application object is assigned to the PDO at index 1BFF hex (name: 512th transmit PDO mapping). This PDO is a TxPDO. The application object contains the Sysmac error status at index 2001 hex and subindex 01 hex.

### ● PDO Mapping When You Use Sysmac Studio with a Built-in EtherCAT Port

When you use Sysmac Studio with the built-in EtherCAT port on an NJ/NX-series CPU or NY-series Industrial PC, a PDO mapping object is called an *I/O entry mapping*. The application object is called an *I/O entry*, and it is referenced by NX objects.

You can add or delete I/O entries for some I/O entry mappings but not for others.

Default I/O entries are mapped to the I/O entry mappings that allow the addition or deletion of I/O entries. For Units with I/O entry mappings that allow the addition or deletion of I/O entries, you can use the Sysmac Studio to change the default I/O entry mappings.

To change I/O entry mappings for EtherCAT Slave Terminals on the Sysmac Studio, use the I/O allocation settings on the Edit Slave Terminal Configuration Tab Page. Refer to *9-2-4 I/O Allocation Information* on page 9-15 for information on editing I/O allocation settings.

Refer to *9-2-4 I/O Allocation Information* on page 9-15 for details on assigning I/O entry mappings for the EtherCAT Coupler Unit.

Refer to the user's manual for the specific NX Units for details on I/O entry mappings.



#### Additional Information

Refer to *A-4 Connecting to Masters from Other Manufacturers* on page A-12 for the application object references in masters and tools from other manufacturers.

### 8-4-3 Assigning PDOs

#### Scheme for Assigning PDOs to EtherCAT Slaves

You can assign more than one PDO to an EtherCAT slave.

Here, PDOs are assigned to index 1C12 hex for the RxPDO, and 1C13 hex for the TxPDO.

The following example shows how PDOs are assigned.

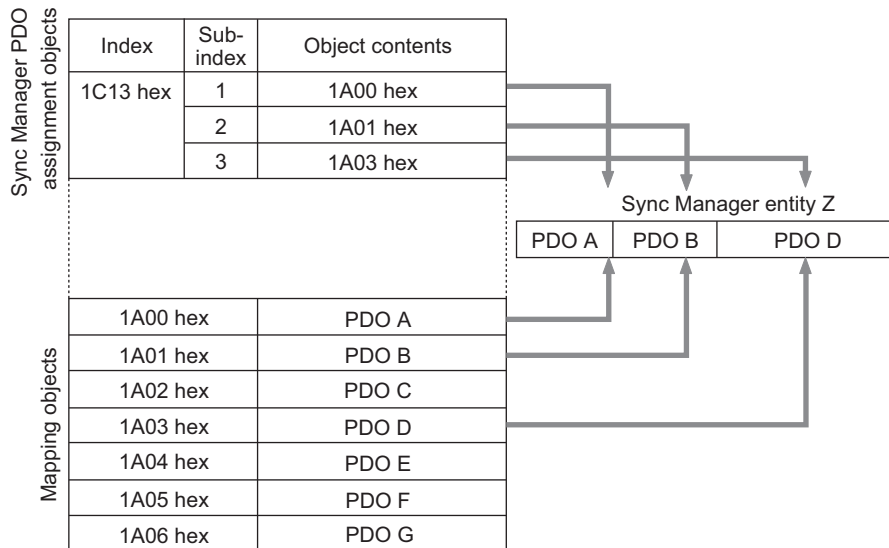

In this example, three PDOs (PDO A, PDO B, and PDO D) are assigned to index 1C13 hex (for the TxPDOs).

Similarly, a PDO (for the RxPDO) is assigned to index 1C12 hex.

These assignments determine the PDOs to use for communications between the EtherCAT master and slave.

#### Assigning PDOs to EtherCAT Slave Terminals

In an EtherCAT Slave Terminal, PDOs are assigned by default to the EtherCAT Coupler Unit and each NX Unit. These PDOs determine both the RxPDOs and TxPDOs that are used for communications with the EtherCAT master.

You can use the Sysmac Studio to change the default PDO assignments for each Unit that allows changes to the PDO mappings.

To change PDO assignments for EtherCAT Slave Terminals on the Sysmac Studio, use the I/O allocation settings on the Edit Slave Terminal Configuration Tab Page.

Refer to 9-2-4 *I/O Allocation Information* on page 9-15 for information on editing I/O allocation settings.

## 8-5 Service Data Objects (SDOs)

### 8-5-1 Introduction

EtherCAT Slave Terminals support SDO communications.

The EtherCAT master can read and write data from and to entries in the object dictionary with SDO communications to make parameter settings and monitor status.

Refer to *A-7 CoE Objects* on page A-31 for the objects that you can use with SDO communications.

### 8-5-2 Abort Codes

The following table lists the abort codes for SDO communications errors.

Value	Meaning
05030000 hex	Toggle bit not changed.
05040000 hex	SDO protocol timeout.
05040001 hex	Client/server command specifier not valid or unknown.
05040005 hex	Out of memory.
06010000 hex	Unsupported access to an object.
06010001 hex	Attempt to read a write-only object.
06010002 hex	Attempt to write to a read-only object.
06020000 hex	The object does not exist in the object directory.
06040041 hex	The object cannot be mapped to the PDO.
06040042 hex	Number/length of mapped objects exceeds PDO length.
06040043 hex	General parameter incompatibility.
06040047 hex	General internal incompatibility in the device.
06060000 hex	Access failed due to a hardware error.
06070010 hex	Data type does not match, length of service parameter does not match.
06070012 hex	Data type does not match, service parameter is too long.
06070013 hex	Data type does not match, service parameter is too short.
06090011 hex	Missing subindex.
06090030 hex	Value of parameter exceeded range (only for write access).
06090031 hex	Value of parameter that was written is too high.
06090032 hex	Value of parameter that was written is too low.
06090036 hex	Maximum value is less than minimum value.
08000000 hex	General error.
08000020 hex	Data cannot be transferred or stored to the application.
08000021 hex	Data cannot be transferred or stored to the application because of local control.
08000022 hex	Data cannot be transferred or stored to the application because of the present device state.
08000023 hex	Failed to dynamically create the object dictionary, or no object dictionary exists.

## 8-6 Communications between an EtherCAT Master and Slaves

This section describes the communications modes between the master and slaves for EtherCAT communications, and the communications modes for EtherCAT Slave Terminals.

### 8-6-1 Communications Modes for Communications between an EtherCAT Master and Slaves

#### Free-Run Mode

In this mode, the slave processes the I/O (i.e., refreshes the I/O data) asynchronous to the communications cycle of the master.

#### DC Mode

In this mode, the slave processes the I/O (i.e., refreshes the I/O data) in synchronization with the communications cycle of the master. In this mode, a mechanism called a distributed clock (DC) is used to synchronize EtherCAT communications. The clock is shared by the master and the slaves. In DC Mode, the master and slaves are synchronized by sharing the same clock. Interruptions (Sync0) are generated in the slaves at precise intervals based on this clock. Each slave executes I/O processing at this precise time.

### 8-6-2 Communications Modes for EtherCAT Slave Terminals

EtherCAT Slave Terminals support the following two communications modes.

- Free-Run Mode
- DC Mode

Refer to *Section 10 I/O Refreshing* on page 10-1 for information on the operation of an EtherCAT Slave Terminal in different communications modes.

### 8-6-3 Communications Cycle

The communications cycle is determined by the setting for it in the EtherCAT master.

The communications cycles in the communications modes of the EtherCAT Slave Terminals are described below.

- Communications Cycle in DC Mode

Refer to *3-1-2 EtherCAT Coupler Unit Specifications* on page 3-2. There are restrictions in the communications cycles that you can set for some of the NX Units. If you use any of those NX Units, set a communications cycle that will satisfy the specifications for the refresh cycles that can be executed by the NX Unit. Refer to the appendix of the *NX-series Data Reference Manual (Cat. No. W525)* to see if there are restrictions on any specific NX Units. For information on the communications cycles that you can set, refer to the user's manuals for the NX Units.

- Communications Cycle in Free-Run Mode

Refer to *3-1-2 EtherCAT Coupler Unit Specifications* on page 3-2. There are restrictions in the communications cycles that you can set for some of the NX Units. If you use any of those NX Units, set a communications cycle that will satisfy the specifications for the refresh cycles that can be executed by the NX Unit. Refer to the appendix of the *NX-series Data Reference Manual (Cat. No. W525)* to see if there are restrictions on any specific NX Units. For information on the communications cycles that you can set, refer to the user's manuals for the NX Units.

Refer to *Specifications of Built-in EtherCAT Port* in the user's manual for the built-in EtherCAT port on the connected CPU Unit or Industrial PC for communications cycles that are supported by the built-in EtherCAT port on the NJ/NX-series CPU Unit or NY-series Industrial PC.



# 9

## Setting Up Slave Terminals

This section describes the procedures used to set up Slave Terminals.

<b>9-1</b>	<b>Settings and Setting Procedures</b> .....	<b>9-2</b>
9-1-1	Items to Set .....	9-2
9-1-2	Slave Terminal Parameters .....	9-2
9-1-3	Variable Assignment Settings.....	9-3
9-1-4	Setting Procedures.....	9-3
<b>9-2</b>	<b>Setting Slave Terminal Parameters</b> .....	<b>9-5</b>
9-2-1	Items to Set .....	9-5
9-2-2	Settings as an EtherCAT Slave .....	9-7
9-2-3	Setting the Unit Configuration Information .....	9-10
9-2-4	I/O Allocation Information .....	9-15
9-2-5	Unit Operation Settings .....	9-26
9-2-6	Unit Application Data .....	9-28
9-2-7	Sysmac Studio Functions Used as Required .....	9-28
<b>9-3</b>	<b>Assigning Variables</b> .....	<b>9-37</b>
9-3-1	Methods to Assign Variables .....	9-37
9-3-2	Assigning Device Variables to I/O Ports .....	9-38
9-3-3	I/O Ports for Status That Accept Device Variable Assignments .....	9-39
9-3-4	Assigning Axis Variables .....	9-40
<b>9-4</b>	<b>Transferring and Comparing Settings</b> .....	<b>9-42</b>
9-4-1	Transferring Settings .....	9-42
9-4-2	Comparing Settings.....	9-45
<b>9-5</b>	<b>Backing Up Settings</b> .....	<b>9-47</b>
9-5-1	Backup Functions .....	9-47
9-5-2	SD Memory Card Backup Function .....	9-47
9-5-3	Sysmac Studio Controller Backup Function .....	9-48
9-5-4	Data That Is Backed Up .....	9-48
9-5-5	Backing Up the Slave Terminal Settings by Transferring Data.....	9-48
<b>9-6</b>	<b>Precautions in Changing the Unit Configuration</b> .....	<b>9-51</b>
9-6-1	I/O Data That Require Specification of NX Unit Numbers .....	9-51
9-6-2	NX Bus Refresh Cycle in DC Mode.....	9-52
9-6-3	Using Settings from NX Units on Other Slave Terminals .....	9-53
9-6-4	Transferring Slave Terminal Setting Information to the Controller.....	9-53

## 9-1 Settings and Setting Procedures

This section describes the settings that are required to access I/O data in EtherCAT Slave Terminals from an NJ/NX-series CPU Unit or NY-series Industrial PC. This section also describes the setting procedures.

### 9-1-1 Items to Set

The settings that are used to access I/O data in the EtherCAT Slave Terminals from an NJ/NX-series CPU Unit or NY-series Industrial PC are given below.

Setting	Description
Setting Slave Terminal parameters	Set the settings of the EtherCAT Coupler Unit as an EtherCAT slave, and the Slave Terminal configuration and operation settings.
Assigning variables	Assign and register the variables that are required to access the I/O data from the user program.

CPU Unit or Industrial PC (EtherCAT master)

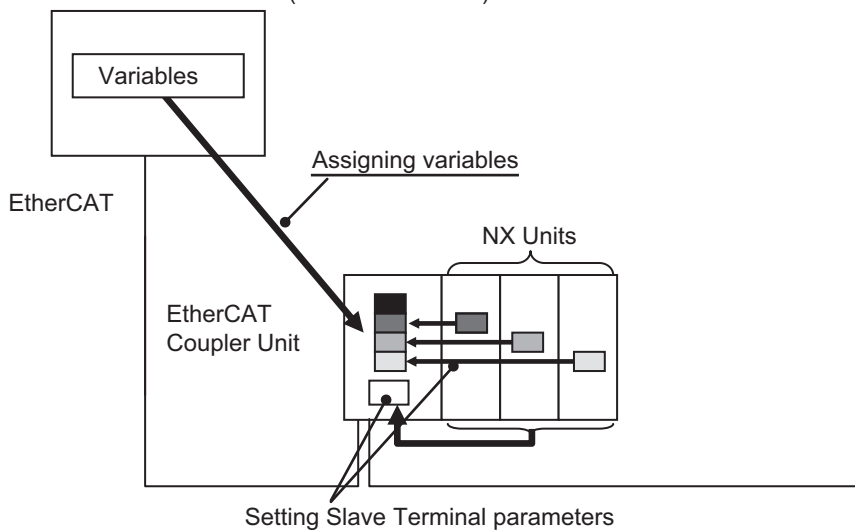

Make the above settings on the Sysmac Studio. Then connect the Sysmac Studio to the CPU Unit or Industrial PC and transfer the settings to the CPU Unit or Industrial PC and to the Slave Terminals.

### 9-1-2 Slave Terminal Parameters

The Slave Terminal parameters must be set to ensure that the EtherCAT Slave Terminal operates as intended, and performs process data communications with the EtherCAT master. The settings are listed in the following table.

Setting	Description
Settings as an EtherCAT slave	These settings are required for operation as an EtherCAT slave.

Setting		Description	
Slave Terminal configuration and operation settings	Configuration information	Unit configuration information	This information describes the Unit configuration of the Slave Terminal.
		I/O allocation information	This information specifies what I/O data in the Units in the Slave Terminal to exchange with process data communications.
	Unit operation settings		These are the operation settings for each Unit in the Slave Terminal.
	Unit application data settings		These data settings enable the functionality that is specific to each Unit.

Refer to 9-2 *Setting Slave Terminal Parameters* on page 9-5 for details on the settings.

### 9-1-3 Variable Assignment Settings

To allow the user program to access a Slave Terminal, you must assign variables in the CPU Unit or Industrial PC to the I/O data in the Slave Terminal.

If the Slave Terminal is connected to an NJ/NX/NY-series Controller, the following methods are available.

Setting	Description
Assigning device variables	Assign and register device variables to the I/O ports.
Assigning Axis Variables	If you are using the Motion Control Function Module for control, assign I/O data (process data) to the Axis Variables.

Refer to 9-3 *Assigning Variables* on page 9-37 for details on the settings.

### 9-1-4 Setting Procedures

Use the following procedures to set up an EtherCAT Slave Terminal for connection to an NJ/NX/NY-series Controller.

<b>1 Setting Slave Terminal parameters</b> Refer to 9-2 <i>Setting Slave Terminal Parameters</i> on page 9-5.	(1) <b>Setting the Slave Terminal as an EtherCAT slave</b>
	↓
	(2) <b>Creating and setting the Unit configuration information</b>
	↓
	(3) <b>Setting the I/O allocation information</b>
	↓
(4) <b>Setting the Unit operation settings</b>	
↓	
(5) <b>Setting Unit application data</b>	



### **2 Assigning variables**

Refer to *9-3 Assigning Variables* on page 9-37.



### **3 Transferring the settings to the Controller**

Refer to *9-4 Transferring and Comparing Settings* on page 9-42.

The above procedure is not used to set up Safety Control Units. For the procedure to set up Safety Control Units, refer to *Commissioning Procedures* in the *NX-series Safety Control Unit User's Manual* (Cat. No. Z930).

## 9-2 Setting Slave Terminal Parameters

This section describes how to set the EtherCAT Slave Terminal parameters.

### 9-2-1 Items to Set

There are the following two types of parameters that must be set in the EtherCAT Slave Terminals.

Setting	Description	Setting location on Sysmac Studio
Settings as an EtherCAT slave	These settings enable the EtherCAT Coupler Unit to perform EtherCAT communications with the EtherCAT master as an EtherCAT slave.	EtherCAT Configuration Edit Tab Page
Slave Terminal configuration and operation settings	These settings enable the EtherCAT Coupler Unit to control the internal processing of the Slave Terminal based on EtherCAT communications, i.e., I/O refreshing for the NX Units, management of the NX Units, etc.	Edit Slave Terminal Configuration Tab Page

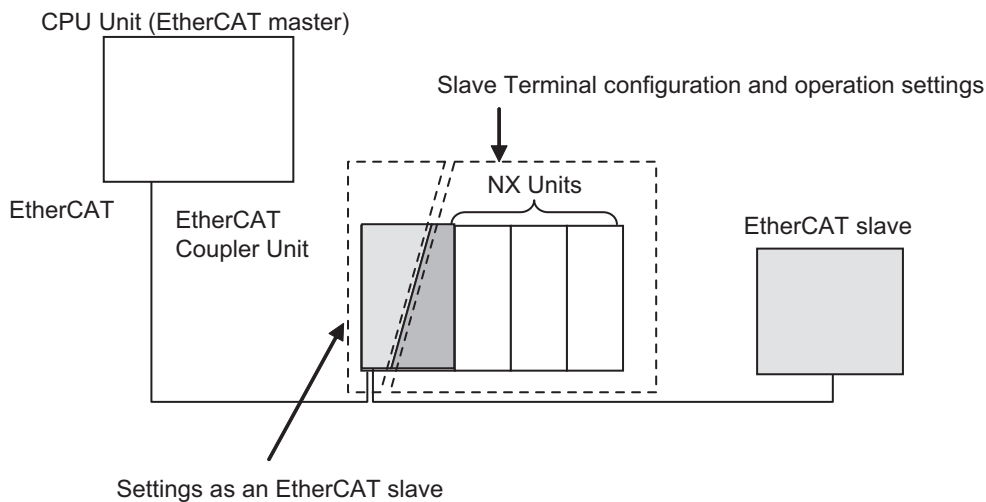

### Settings as an EtherCAT Slave

Register the EtherCAT Coupler Unit in the EtherCAT network and set the settings for the EtherCAT Coupler Unit, such as the node address.

Make these settings on the EtherCAT Configuration Edit Tab Page on the Sysmac Studio.

Refer to 9-2-2 *Settings as an EtherCAT Slave* on page 9-7 for details on the settings.

## Slave Terminal Configuring and Operation Settings

These settings are used to control the Units in the Slave Terminal.

Create the Unit Configuration of the Slave Terminal, and set up each Unit.

Make the settings on the Edit Slave Terminal Configuration Tab Page on the Sysmac Studio.

The Slave Terminal has the following setting information.

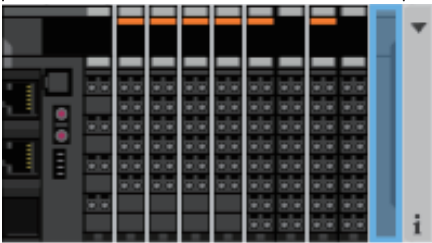
Name		Description
Configura- tion informa- tion	Unit configuration information	This information describes the configuration of the Slave Terminal: the number and order of NX Units mounted after the EtherCAT Coupler Unit, individual Unit information, and information about the EtherCAT Coupler Unit itself.  <div style="text-align: center;">  </div>
	I/O Allocation Information	This information defines the I/O data in the EtherCAT Coupler Unit and the NX Units.
Unit operation settings		The Unit operation settings are for the EtherCAT Coupler Unit and the NX Units.
Unit application data		This data controls the functionality that is specific to each NX Unit. Not all NX Units have Unit application data.

The EtherCAT Coupler Unit and the NX Units have default values for the I/O allocation information. If the default values are used, create and set the Unit configuration information to complete the configuration information settings.

Refer to *9-2-3 Setting the Unit Configuration Information* on page 9-10 to *9-2-6 Unit Application Data* on page 9-28 for details on the Slave Terminal configuration and operation settings.

## 9-2-2 Settings as an EtherCAT Slave

Register the EtherCAT Coupler Unit in the EtherCAT network and set the node address and other settings.

### Settings as an EtherCAT Slave

The parameters of the EtherCAT Coupler Unit as an EtherCAT slave are given below. You can set only the items that have "Yes" in the *Settable* column.

Settings	Settable	Description
Device name	Yes	This is the name of the EtherCAT Coupler Unit. Default value: E *** (* is a serial number from 001). The default value is automatically generated based on the node address. Setting range: Text string
Model name		This is the model of the EtherCAT Coupler Unit.
Product name		This is the product name of the EtherCAT Coupler Unit.
Revision		This is the revision number of the EtherCAT Coupler Unit.
PDO Communications Cycle		This tells whether the EtherCAT Slave Terminal communicates in PDO communications cycle 1 or PDO communications cycle 2. The PDO communications cycle is given in parentheses. This item is displayed only for a built-in EtherCAT port on an NX-series CPU Unit or NY-series Industrial PC. Display example: PDO communications cycle 1 (500 $\mu$ s)
Node Address	Yes	This is the node address. The default value is set automatically when a slave is added. The setting range is the same as the node address range that can be set for the built-in EtherCAT port that connects to the EtherCAT Coupler Unit. For the node address ranges that can be set for a built-in EtherCAT port, refer to the user's manual for the built-in EtherCAT port on the connected CPU Unit or Industrial PC. Set this address to the same node address that is set on the EtherCAT Coupler Unit. If you set the node address on the EtherCAT Coupler Unit switches, set the node address on the Sysmac Studio to the same value. If you write the node address from the Sysmac Studio, set the switches on the EtherCAT Coupler Unit to the same value. Refer to <i>4-3-3 Setting the Node Address</i> on page 4-13 for the node address setting on the EtherCAT Coupler Unit.
Enable/Disable Settings	Yes	Enables or disables the EtherCAT Slave Terminal as a communications target. <ul style="list-style-type: none"> <li>Enabled: The Slave Terminal will operate.</li> <li>Disabled: The Slave Terminal will not operate.*1</li> </ul> Default setting: Enabled
Serial Number		This is the serial number of the EtherCAT Coupler Unit. Default: 0x00000000 (when offline) The value is updated to the serial number of the physical slave when you select <b>Get Slave Serial Numbers</b> from the menu for the master. A <i>Network Configuration Verification Error</i> occurs if the serial number on the Sysmac Studio and the serial number of the physical slave do not agree when the <b>Serial Number Check Method</b> in the master settings is set to <b>Setting = Actual device</b> . For details on how to obtain the serial numbers for actual devices, refer to the user's manual for the built-in EtherCAT port on the connected CPU Unit or Industrial PC.

Settings	Set-table	Description
PDO Map Settings		This is a list of the valid PDOs. The PDO mappings for the EtherCAT Slave Terminal depend on the I/O allocations to the Slave Terminal. The PDO mappings are not displayed because you do not directly edit the PDO mappings for the EtherCAT Coupler Unit.
Enable Distributed Clock	Yes	These settings enable or disable the DC and specify the I/O refreshing methods for the mounted NX Units. The settings are as follows: <ul style="list-style-type: none"> <li>• Enabled (DC for synchronization)</li> <li>• Enabled (DC with priority in cycle time)</li> <li>• Disabled (FreeRun)</li> </ul> Default setting: Enabled (DC for synchronization) <i>Enabled (DC with priority in cycle time)</i> is displayed only for the NX-ECC203 EtherCAT Coupler Unit. Refer to <i>10-3-2 Setting the I/O Refreshing Methods</i> on page 10-9 for details on NX Unit I/O refreshing method for each setting.
Reference Clock		This setting tells whether the slave provides a reference clock. This setting indicates having a reference clock because the EtherCAT Coupler Unit has its own reference clock.
Setting Parameters	Yes	This setting affects the parameters that are automatically set by the EtherCAT master when EtherCAT communications start or when a slave is reconnected.
Backup Parameter Settings		This setting is for backup parameters. The backup parameters for the EtherCAT Coupler Unit cannot be set here. Set the backup parameters in the Unit operation settings.
Slave Terminal Configuration	Yes	These settings are for the Slave Terminal. Click the <b>Edit Slave Terminal Configuration</b> Button to edit these parameters.

\*1. Register Slave Terminals that are not installed on the EtherCAT network but are scheduled for addition at a later date as **disabled** Slave Terminals. Even for a **disabled** Terminal, you can set process data allocations and use the process data through system-defined variables and device variables in the user program.

## ● Setting Parameter

The setting parameter is given in the following table.

Setting	Setting range	Description
Diagnosis History/Flags	0 or 1	This parameter specifies whether notification is provided with emergency messages. 0: No notification 1: Notification The default setting is 0.

## Setting Up the Slave Terminal as an EtherCAT Slave

- 1 Double-click **EtherCAT** under **Configurations and Setup** in the Multiview Explorer. Or, right-click **EtherCAT** under **Configurations and Setup** and select **Edit**.
- 2 Drag an EtherCAT Coupler Unit from the Toolbox to the EtherCAT Configuration Edit Tab Page and drop it under the master.  
The EtherCAT Coupler Unit is added under the master.

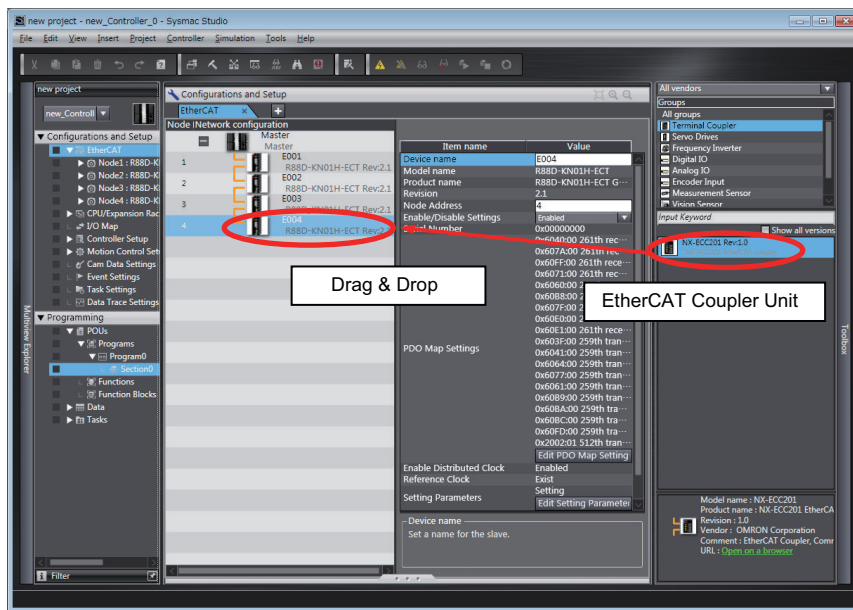

- 3 Select the EtherCAT Coupler Unit on the EtherCAT Configuration Edit Tab Page. The slave parameters of the EtherCAT Coupler Unit as an EtherCAT slave are displayed in the Slave Parameters Pane on the right side of the EtherCAT Configuration Edit Tab Page.

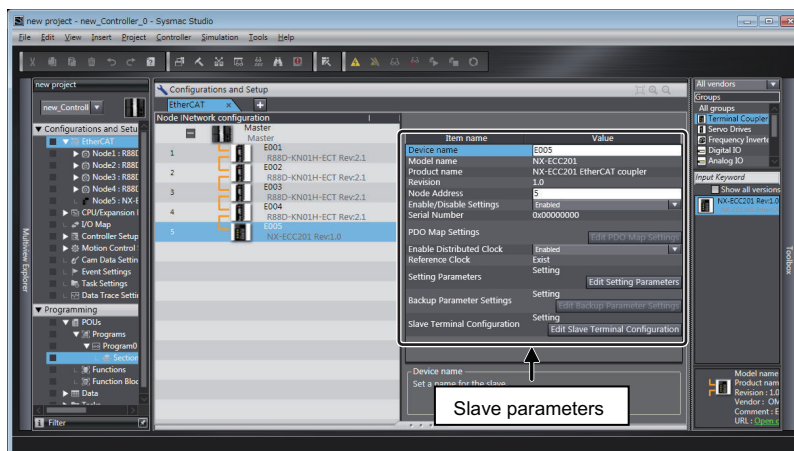

- 4 Set the parameters.



### Additional Information

You can export the EtherCAT network configuration information from Sysmac Studio version 1.12 or higher to a CSV file. Refer to the *Sysmac Studio Version 1 Operation Manual (Cat. No. W504)* for details on exporting the EtherCAT network configuration information.

## 9-2-3 Setting the Unit Configuration Information

Specify the Unit configuration information for the Slave Terminal, which consists of an EtherCAT Coupler Unit and NX Units.

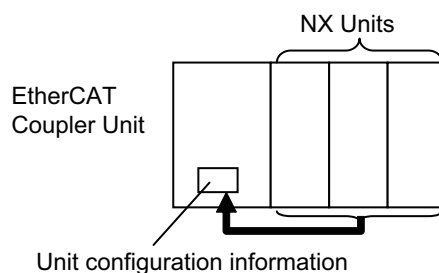

## Settings in the Unit Configuration Information

### ● EtherCAT Coupler Unit

The EtherCAT Coupler Unit settings are listed below.

You can set only the items that have Yes in the Settable column.

Setting	Settable	Description	Data range	Default
Device name		This is the name of the EtherCAT Coupler Unit. Use the EtherCAT Configuration Edit Tab Page to change this setting.	---	E *** (* is a serial number from 001). The default value is automatically generated based on the node address.
Model name		This is the model of the EtherCAT Coupler Unit.	---	The model number of the EtherCAT Coupler Unit is shown.
Product name		This is the product name.	---	EtherCAT Coupler
Unit version		This is the Unit version of the EtherCAT Coupler Unit.	---	---
NX Unit Number		This number represents the logical position of the EtherCAT Coupler Unit.	---	0
NX Unit Mounting Setting		This setting enables or disables the mounting of an NX Unit. You cannot directly edit these settings in the EtherCAT Coupler Unit.	---	---
Serial Number		This is the serial number of the EtherCAT Coupler Unit. You can get the serial number to set the serial number of the actual EtherCAT Coupler Unit.	---	---

Setting	Settable	Description	Data range	Default
Supply Power/Available Power [W]		The power that is currently drawn by the NX Units and the maximum available power supply capacity are given.	---	-/10.00
Unit width [mm]		This is the width of the EtherCAT Coupler Unit.	---	46
I/O allocation settings	Yes	These are the I/O allocation settings for the EtherCAT Coupler Unit. Click the <b>Edit I/O Allocation Settings</b> Button to edit these settings.	---	Refer to 9-2-4 I/O Allocation Information on page 9-15.
Unit operation settings	Yes	These are the Unit operation settings for the EtherCAT Coupler Unit. Click the <b>Edit Unit Operation Settings</b> Button to edit these settings.	---	Refer to 9-2-5 Unit Operation Settings on page 9-26.
Number of mounted Units		This is the number of mounted NX Units.	---	---
NX Unit Connection Time (s)	Yes	This is the wait time for the NX Units to connect to the Slave Terminal.	3 to 200 s	3 s
Serial Number Check Method	Yes	Set this setting to <i>Setting = Actual device</i> to compare the serial numbers of the NX Units at these times: when the power is turned ON and after the EtherCAT Coupler Unit is restarted. The serial numbers of the NX Units saved in the Unit configuration information are compared with the actual serial numbers of the NX Units.*1 If differences are found, a <i>Unit Configuration Verification Error</i> will occur.	No check. Setting = Actual device	No check.

\*1. If this setting is set to **Setting = Actual device** and you replace an NX Unit in the Slave Terminal, an *Unit Configuration Verification Error* will occur. A *Unit Configuration Verification Error* will also occur if you swap the mounting position of two Units of the same model. If it becomes necessary to replace an NX Unit, or swap the mounting positions of two Units of the same model while this setting is set to **Setting = Actual device**, you must correct the Unit configuration information and download it to the EtherCAT Coupler Unit. Set this parameter to **Setting = Actual device** if strict management of the equipment configuration is required.

## ● NX Units

Name	Settable	Description	Data range	Default
Device name	Yes	The name of the NX Unit.	---	N* (Where * is a serial number from 1)
Model name		This is the model number of the NX Unit.	---	---
Product name		This is the product name.	---	---
Unit version		This is the Unit version of the NX Unit.	---	---
NX Unit Number		This number represents the logical position of the NX Unit. Numbers are automatically assigned from the leftmost mounting position.	---	---
NX Unit Mounting Setting	Yes	This setting enables or disables the mounting of an NX Unit. Refer to 11-2 NX Unit Mounting Settings on page 11-6 for details on this setting.	Enabled or Disabled	Enabled

Name	Set-table	Description	Data range	Default
Serial Number		This is the serial number of the NX Unit. You can get the serial number to set the serial number of the actual EtherCAT Coupler Unit.	---	0
Supply Power/ Available Power [W]		The power that is currently drawn by the NX Units and the maximum available power supply capacity are given. This item is for an Additional NX Unit Power Supply Unit.	---	-/10.00
Power consumption [W]		This is the power consumption of the NX Units from the NX bus. This setting applies to Units other than an Additional NX Unit Power Supply Unit.	---	Refer to the manual for the specific NX Unit.
Unit width [mm]		This is the width of the NX Unit.	---	Refer to the manual for the specific NX Unit.
I/O allocation settings	Yes	These are the I/O allocation settings for the NX Unit. Click the <b>Edit I/O Allocation Settings</b> Button to edit these settings. You cannot change this setting for System Units.	---	Refer to the manual for the specific NX Unit.
Unit operation settings	Yes	These are the Unit operation settings for the NX Unit. Click the <b>Edit Unit Operation Settings</b> Button to edit these settings. You cannot change this setting for System Units.	---	Refer to the manual for the specific NX Unit.

## Setting the Unit Configuration Information

### ● Creating the Unit Configuration Information with the Edit Slave Terminal Configuration Tab Page

- 1** Double-click **EtherCAT** under **Configurations and Setup** in the Multiview Explorer.  
Or, right-click **EtherCAT** under **Configurations and Setup** and select **Edit**.  
The EtherCAT Configuration Edit Tab Page is displayed.
- 2** Drag the EtherCAT Coupler Unit from the Toolbox to the Edit Pane and drop it under the master.  
The EtherCAT Coupler Unit is added under the master.
- 3** Click the **Edit Slave Terminal Configuration** Button next to **Slave Terminal Configuration** in the slave parameters for the EtherCAT Coupler Unit.  
The Edit Slave Terminal Configuration Tab Page is displayed.

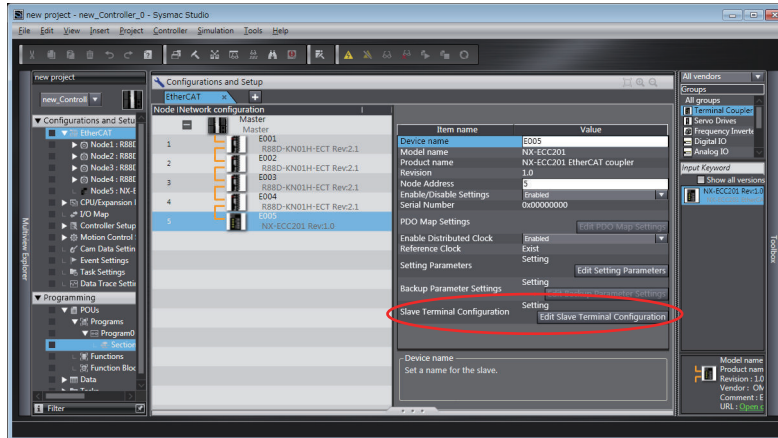

**4** Drag the NX Unit from the Toolbox to the Edit Configuration Pane and drop it on the Slave Terminal.

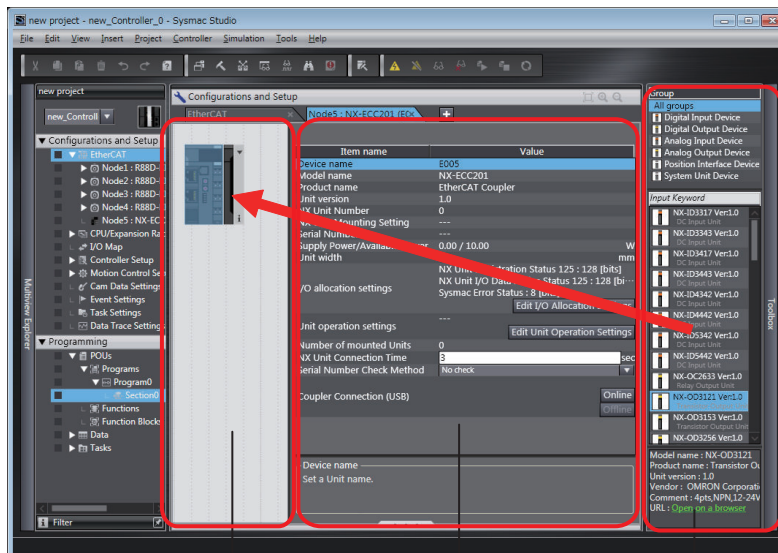

Labels pointing to the configuration pane: Edit Slave Terminal Configuration Pane, Unit Settings Pane, Toolbox

Item	Description
Edit Configuration Pane	You can edit the Unit configuration information for the Slave Terminal here.
Unit Settings Pane	This list displays the setting information for the currently selected Unit. <ul style="list-style-type: none"> <li>• <b>Edit I/O Allocation Settings</b> Button: Click this button to change the I/O allocation information.</li> <li>• <b>Edit Unit Operation Settings</b> Button: Click this button to edit the Unit operation settings.</li> </ul>
Toolbox	This area shows the NX Units by groups and individual Units.

**5** Set the Unit configuration information in the Unit Settings Pane.



### Precautions for Correct Use

---

- If you turn ON the power to an EtherCAT Slave Terminal before you create or transfer *the Unit configuration information* to the Slave Terminal, the TS indicator on the front panel of the EtherCAT Coupler Unit will flash green at 0.5-second intervals. This means that the Slave Terminal is operating without any Unit configuration information.  
In this state, the Slave Terminal will start and operate based on the physical Unit configuration when the power is turned ON. The Unit configuration is not checked. Also, variables are not automatically assigned to the I/O ports, which means you cannot access the EtherCAT Slave Terminal from the program in the NJ/NX-series CPU Unit or NY-series Industrial PC. Always create the *Unit configuration* and transfer it to the EtherCAT Coupler Unit.
  - To refresh I/O for EtherCAT Slave Terminals that operate in DC Mode, create the configuration of all EtherCAT Slave Terminals and make the settings for the EtherCAT Slave Terminals first, and then allocate the EtherCAT Slave Terminal periodic task and make the task settings for the EtherCAT Slave Terminal in the Task Settings in the Controller Setup of the Sysmac Studio. If you set a primary period that is shorter than the NX bus refresh cycle that is automatically calculated by the Sysmac Studio for the EtherCAT Slave Terminals, it will not be possible to transfer the parameter settings of the EtherCAT Slave Terminals through the CPU Unit or Industrial PC. If you try to transfer the parameter settings through the USB port on the EtherCAT Coupler Unit, a Synchronization Cycle Setting Error will occur.  
You can use the Sysmac Studio to check to see if the NX bus refresh cycle exceeds the task periods of the periodic tasks. If you import a Slave Terminal configuration, use the Sysmac Studio to see if the task periods of the periodic tasks are shorter than the NX bus refresh cycle.  
Refer to *10-3-5 Setting the Task Periods of Periodic Tasks* on page 10-18 for the confirmation procedure.
- 



### Additional Information

---

You can export the EtherCAT Slave Terminal configuration information from Sysmac Studio version 1.12 or higher to a CSV file. Refer to the *Sysmac Studio Version 1 Operation Manual (Cat. No. W504)* for details on exporting the EtherCAT Slave Terminal configuration information.

---

## ● Creating Unit Configuration Information Based on the Actual Configuration

This method uses the physical Unit configuration for the Unit configuration information.

Connect the Sysmac Studio to the EtherCAT network through the CPU Unit or Industrial PC. Compare and merge with the actual network configuration to read the actual network configuration information. Then use comparing and merging with the actual Unit configuration to read the Unit configuration of the EtherCAT Slave Terminal. Finally, set the settings as an EtherCAT slave on the EtherCAT Configuration Edit Tab Page, and create the Slave Terminal configuration and operation settings on the Edit Slave Terminal Configuration Tab Page.

For details on comparing and merging with the actual EtherCAT network configuration, refer to *Comparing and Merging EtherCAT Network Configurations and Automatically Creating the Network Configuration* in the user's manual for the built-in EtherCAT port on the connected CPU Unit or Industrial PC.

Refer to *Comparing and Merging with Actual Unit Configuration of the Slave Terminal* on page 9-29 under *9-2-7 Sysmac Studio Functions Used as Required* on page 9-28 for details on the comparing and merging with the actual Unit configuration of the Slave Terminal.

## Changing the Model of an EtherCAT Coupler Unit or NX Unit

You can use the Sysmac Studio to change the models and unit versions of EtherCAT Coupler Units and NX Units that are registered in a project on the Sysmac Studio. For details on how to make these changes with the Sysmac Studio, refer to *Changing the Model of an EtherCAT Coupler Unit or NX Unit* on page 9-32 in *9-2-7 Sysmac Studio Functions Used as Required* on page 9-28.

### 9-2-4 I/O Allocation Information

The I/O allocation information tells what I/O data in the EtherCAT Coupler Unit and the NX Units to exchange with process data communications.

The EtherCAT Slave Terminal performs process data communications with the EtherCAT master based on the I/O allocation information.

CPU Unit or Industrial PC (EtherCAT master)

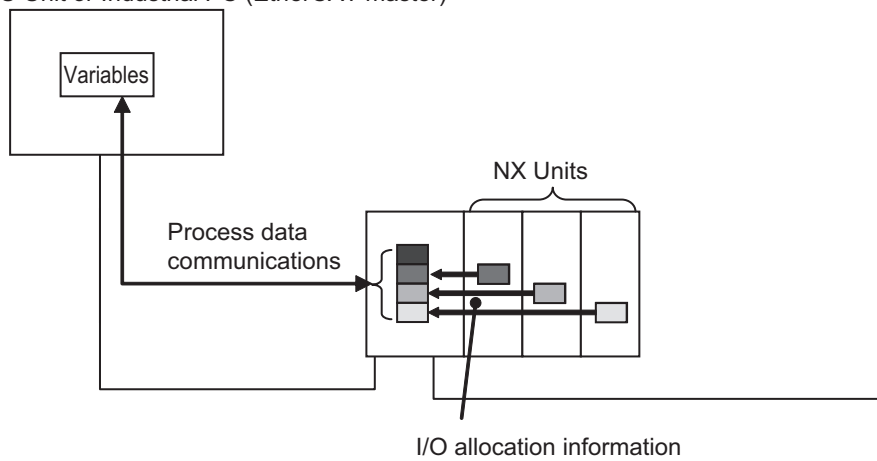

The EtherCAT Coupler Unit and the NX Units contain default values for the I/O allocation information. These default values are sufficient for a standard exchange of I/O data. Change the settings as necessary.

## Specifications for I/O Data Allocations in EtherCAT Slave Terminals

The following limitations apply to I/O data allocations for the entire EtherCAT Slave Terminal.

Item	Input data	Output data
Number of I/O entry mappings	255	255
I/O data size	1,024 bytes	1,024 bytes
Allocatable I/O data points	Maximum of 4,000 points total for both inputs and outputs	

### I/O Allocation Settings

To allocate I/O, select an I/O entry mapping and register an I/O entry to the I/O entry mapping.

#### ● Selecting I/O Entry Mappings

An I/O entry mapping defines a set of I/O data. Each Unit has its own I/O entry mapping.

The data for each I/O entry included in the selected I/O entry mappings are exchanged using process data communications. Default values are assigned to the I/O entry mapping selections. Change the I/O entry mapping selections as necessary. If an I/O entry mapping must be selected, the option to deselect it will not be available.

● **Registering I/O Entries**

The I/O data assigned to an I/O entry mapping is called an I/O entry.

Default values are assigned to the I/O entries in each I/O entry mapping. Some I/O entry mappings allow you to add or delete I/O entries. Also, the I/O data that you can assign to an I/O entry mapping is predetermined. Change the I/O entries as necessary.

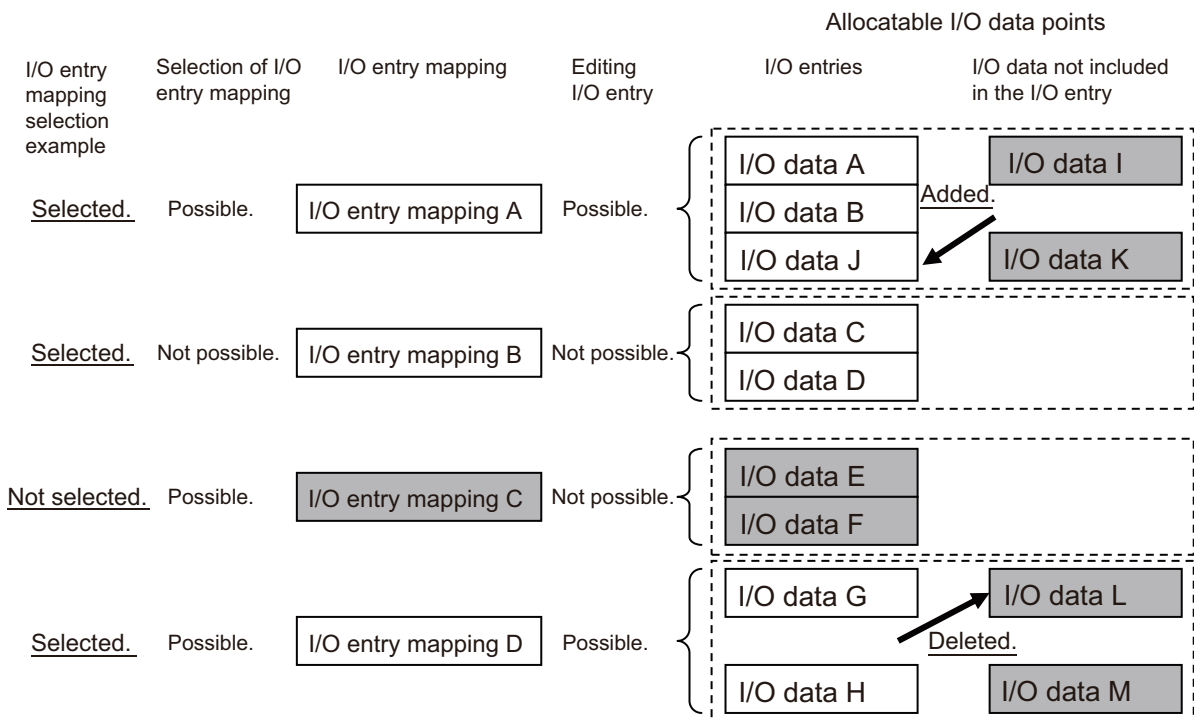

\*The shaded I/O data is not exchanged with process data communications.



**Precautions for Correct Use**

Assign the I/O data that you will use in the user program. Some of the I/O data for the EtherCAT Slave Terminal are not assigned by default. For example, the NX\_DOutTimeStamp instruction uses the Time Stamp of Synchronous Output, which is I/O data, as an input variable, but it is not assigned by default in the EtherCAT Coupler Unit. If you do not assign the Time Stamp of Synchronous Output, you cannot use the NX\_DOutTimeStamp instruction.

**Allocatable I/O Data in an EtherCAT Coupler Unit**

This section gives the I/O data in the EtherCAT Coupler Unit that you can assign as I/O.

To assign I/O data to an NJ/NX-series CPU Unit or NY-series Industrial PC, use the I/O ports for the allocated I/O data.

To access I/O data as NX objects, use the index numbers.

## ● I/O Entry Mappings for EtherCAT Coupler Units

The following I/O entry mappings are available.

I/O	I/O entry mapping name	I/O entry mapping		I/O entry	
		Selecting	Default	Editing	Maximum entries
Inputs	505th Transmit PDO Mapping	Possible.	Selected.	Possible.	6
	511th Transmit PDO Mapping	Possible.	Not selected.	Not possible.	2
	512th Transmit PDO Mapping	Not possible.	Selected.	Not possible.	1

## ● I/O Data Allocatable to I/O Entry Mappings

The following I/O data can be registered as I/O entries for the I/O entry mappings.

The following shows details on each I/O entry mapping.

### a) 505th Transmit PDO Mapping

If you use a status that has a number as the suffix to the data name, select a status according to the number of used NX Units. Doing so will suppress the I/O data size and improve communications performance. For example, if you use 10 NX Units, we recommend that you use the status that has *Status 15* in the data name.

Data name	Function	Data type	Default	I/O port name	Registered by default		NX object	
					NX-ECC201 or NX-ECC202	NX-ECC203	Index number	Subindex number
NX Unit Registration Status 15	This is the registration status for 15 NX Units.	AR-RAY[0..15] OF BOOL	FALSE	NX Unit Registration Status 15			2003 hex	01 hex
NX Unit Registration Status 31	This is the registration status for 31 NX Units.	AR-RAY[0..31] OF BOOL	FALSE	NX Unit Registration Status 31			2003 hex	02 hex
NX Unit Registration Status 63	This is the registration status for 63 NX Units.	AR-RAY[0..63] OF BOOL	FALSE	NX Unit Registration Status 63		Yes	2003 hex	03 hex
NX Unit Registration Status 125	This is the registration status for 125 NX Units.	AR-RAY[0..125] OF BOOL	FALSE	NX Unit Registration Status 125	Yes		2003 hex	04 hex
NX Unit Message Enabled Status 15	This tells whether message communications are enabled for 15 NX Units.	AR-RAY[0..15] OF BOOL	FALSE	NX Unit Message Enabled Status 15			2004 hex	01 hex
NX Unit Message Enabled Status 31	This tells whether message communications are enabled for 31 NX Units.	AR-RAY[0..31] OF BOOL	FALSE	NX Unit Message Enabled Status 31			2004 hex	02 hex

Data name	Function	Data type	Default	I/O port name	Registered by default		NX object	
					NX-ECC201 or NX-ECC202	NX-ECC203	Index number	Subindex number
NX Unit Message Enabled Status 63	This tells whether message communications are enabled for 63 NX Units.	ARRAY[0..63] OF BOOL	FALSE	NX Unit Message Enabled Status 63			2004 hex	03 hex
NX Unit Message Enabled Status 125	This tells whether message communications are enabled for 125 NX Units.	ARRAY[0..125] OF BOOL	FALSE	NX Unit Message Enabled Status 125			2004 hex	04 hex
NX Unit I/O Data Active Status 15	This tells whether I/O data is usable for 15 NX Units.	ARRAY[0..15] OF BOOL	FALSE	NX Unit I/O Data Active Status 15			2005 hex	01 hex
NX Unit I/O Data Active Status 31	This tells whether I/O data is usable for 31 NX Units.	ARRAY[0..31] OF BOOL	FALSE	NX Unit I/O Data Active Status 31			2005 hex	02 hex
NX Unit I/O Data Active Status 63	This tells whether I/O data is usable for 63 NX Units.	ARRAY[0..63] OF BOOL	FALSE	NX Unit I/O Data Active Status 63		Yes	2005 hex	03 hex
NX Unit I/O Data Active Status 125	This tells whether I/O data is usable for 125 NX Units.	ARRAY[0..125] OF BOOL	FALSE	NX Unit I/O Data Active Status 125	Yes		2005 hex	04 hex
NX Unit Error Status 15	This gives the error status for 15 NX Units.	ARRAY[0..15] OF BOOL	FALSE	NX Unit Error Status 15			2006 hex	01 hex
NX Unit Error Status 31	This gives the error status for 31 NX Units.	ARRAY[0..31] OF BOOL	FALSE	NX Unit Error Status 31			2006 hex	02 hex
NX Unit Error Status 63	This gives the error status for 63 NX Units.	ARRAY[0..63] OF BOOL	FALSE	NX Unit Error Status 63			2006 hex	03 hex
NX Unit Error Status 125	This gives the error status for 125 NX Units.	ARRAY[0..125] OF BOOL	FALSE	NX Unit Error Status 125			2006 hex	04 hex

Data name	Function	Data type	Default	I/O port name	Registered by default		NX object	
					NX-ECC201 or NX-ECC202	NX-ECC203	Index number	Subindex number
Time Stamp of Synchronous Input	This time stamp tells when a synchronous input occurred in the NX Unit. Units: ns	ULINT	0	Time Stamp of Synchronous Input			200A hex	01 hex
Time Stamp of Synchronous Output	This time stamp tells when a synchronous output occurred in the NX Unit. Units: ns	ULINT	0	Time Stamp of Synchronous Output			200A hex	02 hex

## b) 511th Transmit PDO Mapping

Data name	Function	Data type	Default	I/O port name	Registered by default		NX object	
					NX-ECC201 or NX-ECC202	NX-ECC203	Index number	Subindex number
New Messages Available	This tells whether the error log is updated.	WORD	0000 hex	New Messages Available	*1		200B hex	01 hex

\*1. You can use this with NX-ECC203 version 1.5 or later. You cannot use this with NX-ECC201 and NX-ECC202.

## c) 512th Transmit PDO Mapping

Data name	Function	Data type	Default	I/O port name	Registered by default		NX object	
					NX-ECC201 or NX-ECC202	NX-ECC203	Index number	Subindex number
Sysmac Error Status	This is the Sysmac error status. It gives the level of the error in the EtherCAT Slave Terminal.	BYTE	02 hex	Sysmac Error Status	Yes	Yes	2001 hex	01 hex

The next section describes each data item in detail.

## Details of I/O Data in the EtherCAT Coupler Unit

This section describes the I/O data in detail.

## ● NX Unit Registration Status

Data name	Description
NX Unit Registration Status 15	This status tells whether the NX Units are registered in the Unit Configuration.
NX Unit Registration Status 31	The status is acquired for as many NX Units as the numeric suffix at the end of the data name. Select the I/O data with the appropriate numeric value based on the number of NX Units that are mounted.
NX Unit Registration Status 63	This status is given as an array of BOOL data. The subscript of the array corresponds to the NX Unit number. A subscript of 0 indicates the EtherCAT Coupler Unit.
NX Unit Registration Status 125	<p>Each bit has the following meaning.</p> <p>TRUE: Registered FALSE: Not registered</p> <p>If the Unit configuration information is registered, the status is TRUE for each Unit that is registered.</p> <p>If the Unit configuration information was automatically created (with only the actual Unit configuration information and no registered information), the status is FALSE for all Units.</p> <p>The status is <i>TRUE</i> for NX Units that are set as unmounted Units.</p> <p>Each bit is updated at the following times.</p> <ul style="list-style-type: none"> <li>• If the Unit Configuration Information Is Registered: The status changes to TRUE when the system is started. The status changes to FALSE when the configuration information is cleared.</li> <li>• If the Unit Configuration Information Is Automatically Created: The status changes to TRUE when the configuration information is confirmed. The status is always FALSE if the Unit configuration information is automatically created.</li> </ul>

## ● NX Unit Message Enabled Status

Data name	Description
NX Unit Message Enabled Status 15	This status tells whether the NX Units can process message communications.
NX Unit Message Enabled Status 31	The status is acquired for as many NX Units as the numeric suffix at the end of the data name. Select the I/O data with the appropriate numeric value based on the number of NX Units that are mounted.
NX Unit Message Enabled Status 63	This status is given as an array of BOOL data. The subscript of the array corresponds to the NX Unit number. A subscript of 0 indicates the EtherCAT Coupler Unit.
NX Unit Message Enabled Status 125	<p>Each bit has the following meaning.</p> <p>TRUE: Message communications possible.</p> <p>FALSE: Message communications not possible.</p> <p>The status says that <i>message communications are enabled</i> for NX Units that meet the following conditions.</p> <ul style="list-style-type: none"> <li>• The comparison shows no differences (only if the Unit configuration information is registered).</li> <li>• The NX Unit does not have a WDT error.</li> </ul> <p>The status is <i>FALSE</i> for NX Units that are set as unmounted Units.</p> <p>Each bit is updated when the message communications status changes on the corresponding NX Unit.</p>

## ● NX Unit I/O Data Active Status

Data name	Description
NX Unit I/O Data Active Status 15	This status tells whether the NX Units can process I/O data communications.
NX Unit I/O Data Active Status 31	The status is acquired for as many NX Units as the numeric suffix at the end of the data name. Select the I/O data with the appropriate numeric value based on the number of NX Units that are mounted.
NX Unit I/O Data Active Status 63	This status is given as an array of BOOL data. The subscript of the array corresponds to the NX Unit number. A subscript of 0 indicates the EtherCAT Coupler Unit.
NX Unit I/O Data Active Status 125	<p>Each bit has the following meaning.</p> <p>TRUE: The I/O data in the NX Unit can be used for control.</p> <p>FALSE: The I/O data in the NX Unit cannot be used for control.</p> <p>The status is <i>FALSE</i> for NX Units that are set as unmounted Units.</p> <p>Each bit is updated when the operating status changes on the corresponding NX Unit.</p>

## ● NX Unit Error Status

Data name	Description
NX Unit Error Status 15	This status tells whether an error exists on the NX Units.
NX Unit Error Status 31	The status is acquired for as many NX Units as the numeric suffix at the end of the data name. Select the I/O data with the appropriate numeric value based on the number of NX Units that are mounted.
NX Unit Error Status 63	
NX Unit Error Status 125	<p>This status is given as an array of BOOL data. The subscript of the array corresponds to the NX Unit number. A subscript of 0 indicates the EtherCAT Coupler Unit.</p> <p>Each bit has the following meaning.</p> <p>TRUE: Error FALSE: No error</p> <p>If the Unit configuration information is registered, the status is reported for only the NX Units for which the <i>NX Unit Registration Status</i> is <i>TRUE (registered)</i>. This status is <i>FALSE</i> for all NX Units for which the NX Unit Registration Status is <i>FALSE (not registered)</i>. If automatic generation<sup>*1</sup> is used for the Unit configuration information, the status is given for all NX Units.</p> <p>Each bit is set to TRUE when the level of the error is as follows:</p> <ul style="list-style-type: none"> <li>• Minor fault</li> <li>• Observation</li> </ul> <p>The status is <i>FALSE</i> for NX Units that are set as unmounted Units.</p> <p>Each bit is updated at the following times.</p> <p>The status changes to TRUE when an error occurs.</p> <p>The status changes to FALSE when the error is reset. Even if the cause of the error has been removed, you must reset the error for the status to change to FALSE.</p>

\*1. This applies when only the physical Unit configuration information is used and the Unit configuration information is not registered.

## ● Time Stamps of Synchronous I/O Refresh

Data name	Description
Time Stamp of Synchronous Input	This time stamp tells when a synchronous input occurred in the NX Unit. The unit is ns.
Time Stamp of Synchronous Output	This time stamp tells when a synchronous output occurred in the NX Unit. The unit is ns.

## ● New Messages Available

Data name	Description
New Messages Available	<p>This tells whether the error log is updated.</p> <p>This tells whether the log of errors occurred in the EtherCAT Coupler Unit and NX Units is updated.</p> <p>TRUE: The error log is updated.</p> <p>FALSE: The error log is not updated.</p> <p>The error log is updated at the following times.</p> <p>The status changes to TRUE when the error log is updated.</p> <p>The status changes to FALSE when the subindex number of the most recent error log record is written to subindex 03 hex (Newest Acknowledged Message) depends on the EtherCAT master.</p>

## ● Sysmac Error Status

Data name	Description
Sysmac Error Status	<p>This status gives the Sysmac error status for the EtherCAT Slave Terminal.</p> <p>This is an OR of the error status of the EtherCAT Coupler Unit and NX Units.</p> <p>TRUE: An error of the corresponding level exists.</p> <p>FALSE: No error of the corresponding level exists.</p> <p>Each bit is updated at the following times.</p> <p>The status changes to TRUE when an error occurs.</p> <p>The status changes to FALSE when the error is reset. Even if the cause of the error has been removed, you must reset the error for the status to change to FALSE.</p>

The following table shows the structure of the bits in the Slave Terminal Sysmac error status. Some bits also have their own I/O ports.

Bit	Data name	Description	I/O port
0	(Reserved)	---	---
1	(Reserved)	This bit is always TRUE. This bit does not indicate an error.	---
2 to 3	(Reserved)	---	---
4	Observation	A monitoring error was detected in the Slave Terminal.	Observation
5	Minor fault	A minor fault was detected in the Slave Terminal.	Minor Fault
6	(Reserved)	---	---
7	(Reserved)	---	---

## Data Allocatable to I/O in NX Units

Refer to the manual for the specific NX Unit for details on the allocatable I/O data.

## Viewing I/O Allocation Information

- 1 Select the Unit in the Edit Slave Terminal Configuration Tab Page.

The Unit Settings Pane is displayed for the selected Unit. The I/O entry name and data size are displayed in the **I/O allocation settings**.

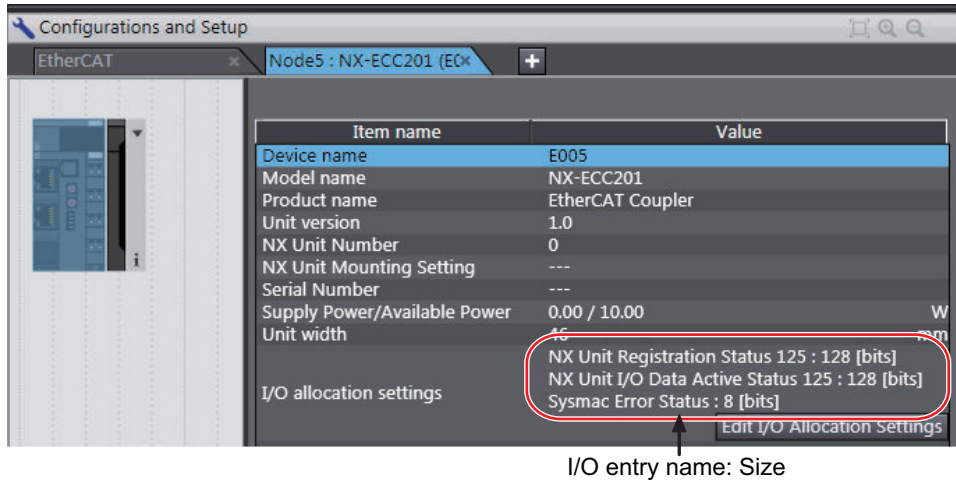

## Editing the I/O Allocation Settings

You can edit the I/O allocations for the EtherCAT Coupler Unit and NX Units as necessary.

- 1 In the Unit Settings Pane, click the **Edit I/O Allocation Settings** Button. The *Edit I/O Allocation Settings* Pane is displayed over the Edit Slave Terminal Configuration Tab Page.

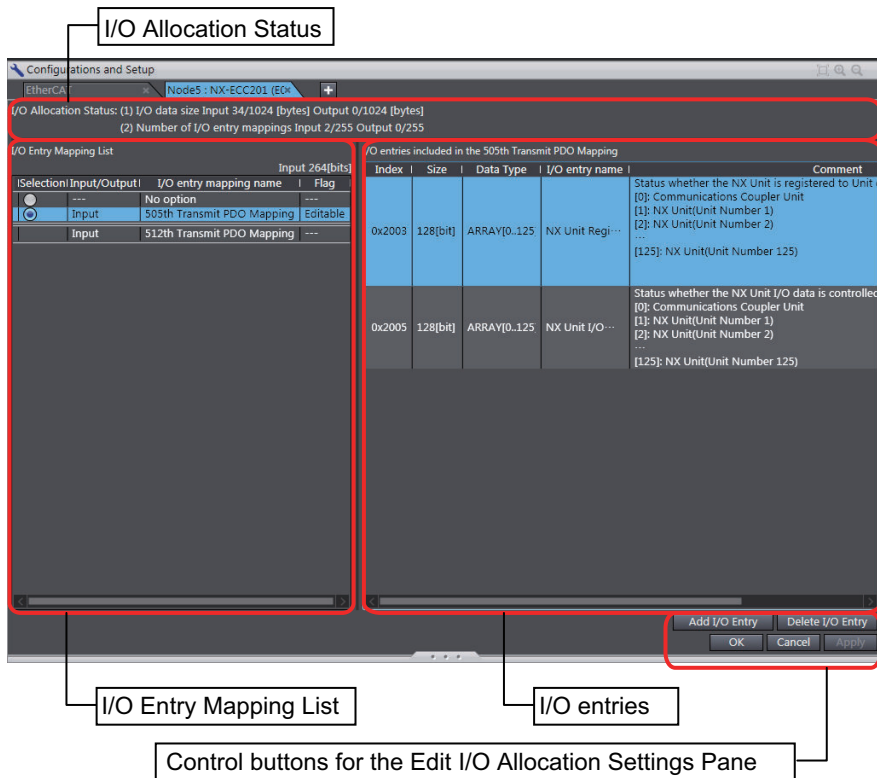

Edit I/O Allocation Settings Pane

Name/Label	Description
I/O Allocation Status	<p>The usage of I/O allocation for the entire EtherCAT Slave Terminal is displayed here.</p> <ol style="list-style-type: none"> <li>1. I/O data size: The size of the I/O data that is allocated for the entire Slave Terminal is given. The denominator is the maximum allocatable size. The I/O data size gives the amount of memory that is used by the I/O data. This value will not necessarily be the same as the total sum of all I/O entry sizes.</li> <li>2. Number of I/O entry mappings: The number of I/O entry mappings that are allocated to the entire Slave Terminal is given. The denominator is the maximum number of allocatable I/O data.</li> </ol>
I/O Entry Mapping List	<p>This is a mapping list of the I/O entries in the corresponding Unit. The I/O entry mapping list shows up to four inputs and outputs respectively. The I/O entry mapping list shows the following items.</p> <ul style="list-style-type: none"> <li>• Selection: This column is used to select the I/O entry mappings that you wish to allocate. Select the I/O entry mapping that you wish to allocate. If you do not want to allocate the I/O entry mapping as part of the I/O allocation information, select <i>No option</i>.</li> <li>• Input/Output: This column shows whether the data is an <i>input</i> or an <i>output</i> in terms of the CPU Unit or Industrial PC.</li> <li>• I/O entry mapping name: This column gives the name of the I/O entry mapping.</li> <li>• Flag: If the I/O entry is editable, this column says <i>Editable</i>. If the I/O entry is not editable, this column says ---.</li> </ul>
I/O entries	<p>This pane allows you to view and edit the I/O entries for the I/O entry mappings that are selected in the I/O Entry Mapping List. Each I/O entry contains the following information.</p> <ul style="list-style-type: none"> <li>• Index: This is the index number for the NX object. The index is displayed after "0x" as <i>index_number:subindex_number</i>.</li> <li>• Size: This column gives the size of the I/O entry data.</li> <li>• Data Type: This column gives the data type of the I/O entry.</li> <li>• I/O entry name: This column gives the name of the I/O entry.</li> <li>• Comment: This column gives a description of the I/O entry.</li> </ul>
Control buttons for the <i>Edit I/O Allocation Settings</i> Pane	<p><b>Add I/O Entry Button:</b> This button adds an I/O entry to the selected I/O entry mapping.</p> <p><b>Delete I/O Entry Button:</b> This button deletes the selected I/O entry from the selected I/O entry mapping.</p> <p><b>OK Button:</b> This button confirms the settings in the Edit I/O Allocation Settings Pane, and returns the display to the Edit Slave Terminal Configuration Tab Page.</p> <p><b>Cancel Button:</b> This button cancels the settings in the Edit I/O Allocation Settings Pane, and returns the display to the Edit Slave Terminal Configuration Tab Page.</p> <p><b>Apply Button:</b> This button confirms the settings in the Edit I/O Allocation Settings Pane, and allows you to edit other I/O entries.</p>

- 2** Select the option button next to the I/O entry mapping that you wish to edit. You can select only **I/O entry mappings** that have the *Editable* in the **Flag** column.

### 3 Click the **Add I/O Entry** Button.

The **Add I/O Entry Dialog Box** is displayed.

A list similar to the one that is shown below is displayed. This list shows the I/O data that you can add to the selected I/O entry mapping list.

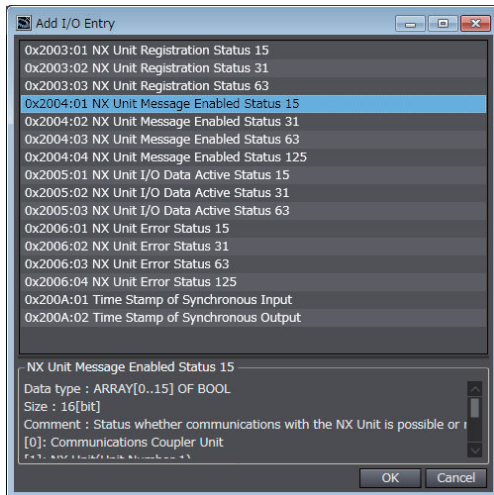

### 4 Select the I/O data to add, and then click the **OK** Button.

The I/O entry is added.

### 5 Click the **Apply** Button or **OK** Button to confirm the current settings.

You can also delete I/O entries. In step 3, select the I/O entry to delete, and then click the **Delete I/O Entry** Button.

## 9-2-5 Unit Operation Settings

### Unit Operation Settings for the EtherCAT Coupler Unit

The operation settings of the EtherCAT Coupler Unit are listed below.

Setting	Setting range	Default	Description
Preventing Incorrect Operation Setting/USB Connection Prohibition Setting	<i>Disable or Enable</i>	<i>Disable</i>	Set whether to prohibit a Sysmac Studio online connection through the peripheral USB port on the EtherCAT Coupler Unit. Select <i>Enable</i> to prohibit the connection. Refer to <i>11-12 Prohibiting USB Connections</i> on page 11-45 for details on prohibiting a USB connection.
Fail-soft Operation Setting/Fail-soft Operation Setting	<i>Stop or Fail-soft operation</i>	<i>Stop</i>	Set whether to use fail-soft operation for the EtherCAT Slave Terminal. Select <i>Fail-soft operation</i> to perform fail-soft operation. Refer to <i>11-11 Fail-soft Operation</i> on page 11-41 for details on fail-soft operation.

Setting	Setting range	Default	Description
Communications Error Setting/Consecutive Communications Error Detection Count	0 to 15	1	A Communications Synchronization Error occurs if the communications error occurs consecutively for more than this set value.
Sync Not Received Timeout Setting/Sync Error Monitoring Time	0 to 600 s (0 implies 120 s.)	0	A Synchronization Interruption Error occurs if the Sync0 signal input does not turn ON within this set value after the EtherCAT Coupler Unit enters the Safe-Operational state.



### Precautions for Safe Use

When you use an NJ/NX-series CPU Unit with the cable redundancy function in DC Mode, set the Communications Error Setting set value for EtherCAT slaves in DC Mode to the following value. If the communications cable is disconnected or the power supply of the EtherCAT slaves is turned OFF with the Communications Error Setting set value set to any other value, communications may discontinue due to a Communications Synchronization Error.

Project unit version 1.42 or later: 2 or higher

Project unit version earlier than 1.42: 1 (default value) or higher

## Unit Operation Settings for the NX Unit

The settings that are available depend on the type of the NX Unit.

For example, Digital Input Units have a setting for the input filter value, and Digital Output Units have a setting for the output value at load rejection.

Refer to the manual for the specific NX Unit for the settings and their meanings.

## Editing the Unit Operation Settings

You can edit the Unit operation settings for the EtherCAT Coupler Unit and NX Units as necessary.

- 1 In the Unit Settings Pane, click the **Edit Unit Operation Settings** Button.  
The Edit Unit Operation Settings Tab Page is displayed.

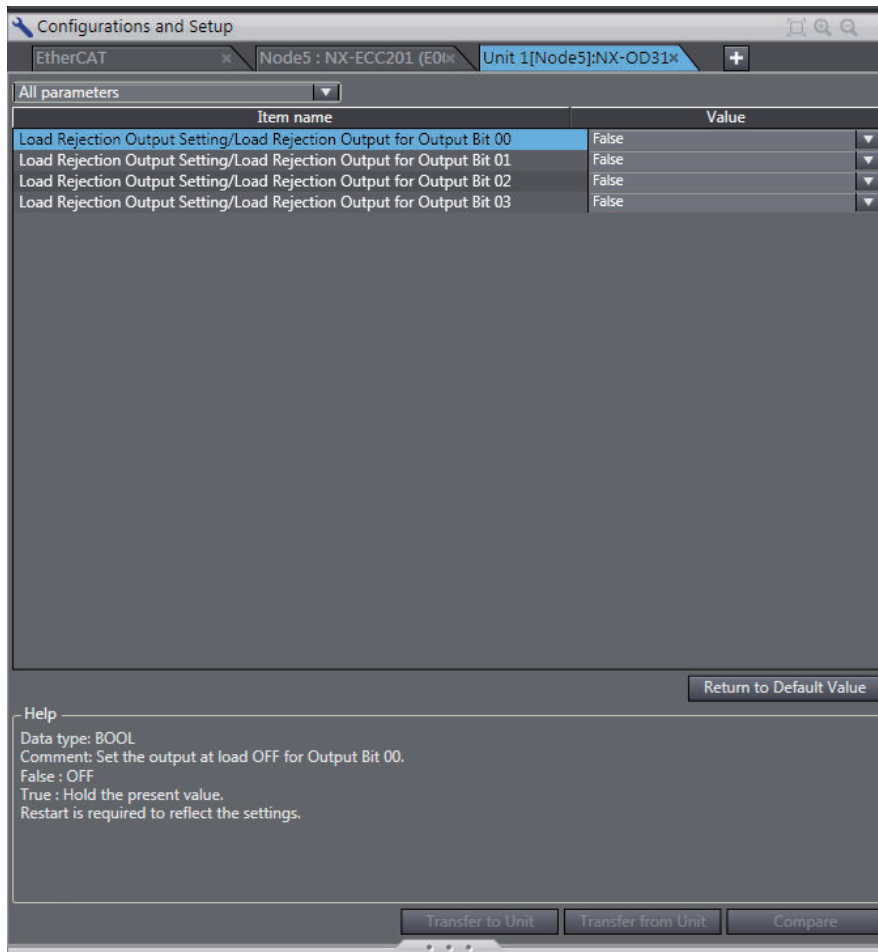

## 2 Change the set value of each setting.

### 9-2-6 Unit Application Data

The Unit application data is the data that enables the functionality that is specific to each NX Unit. Not all NX Units have Unit application data.

Refer to the manual for NX Units that have Unit application data for the method to set and transfer Unit application data.

### 9-2-7 Sysmac Studio Functions Used as Required

You can use the following functions on the Sysmac Studio.

- Comparing and merging with actual Unit configuration of the Slave Terminal
- Getting NX Unit serial numbers
- Exporting/importing Slave Terminal settings and NX Unit settings
- Uploading Slave Terminal settings through the USB port on the EtherCAT Coupler Unit
- Changing the Model of an EtherCAT Coupler Unit or NX Unit
- Displaying the Transmission Delay Times of the EtherCAT Master

## ✓ Version Information

- The function to upload Slave Terminal settings through the USB port on the EtherCAT Coupler Unit was added for a version upgrade to the Sysmac Studio. Refer to *A-11-2 Functions That Were Added or Changed for Each Unit Version* on page A-103 for the versions that support this function.
- The function to change the model of an EtherCAT Coupler Unit was added for a Sysmac Studio version upgrade. Refer to *A-11-2 Functions That Were Added or Changed for Each Unit Version* on page A-103 for the unit versions that support this function. The function to change the model of an NX Unit is supported for Sysmac Studio version 1.06 and higher
- Displaying the transmission delay times of the EtherCAT master was added for a Sysmac Studio upgrade. You can use it with Sysmac Studio version 1.13 or higher.

## Comparing and Merging with Actual Unit Configuration of the Slave Terminal

You can compare the Unit configuration information in an EtherCAT Slave Terminal that was created offline with the actual Unit configuration. You can also use this command to merge a configuration that was created offline with the actual configuration.

- 1 Go online, right-click anywhere in the Edit Slave Terminal Configuration Tab Page, and select **Compare and Merge with Actual Unit Configuration**.  
The actual Unit configuration is read and compared with the Unit configuration on the Sysmac Studio. The results are displayed in the **Compare and Merge with Actual Unit Configuration** Dialog Box.

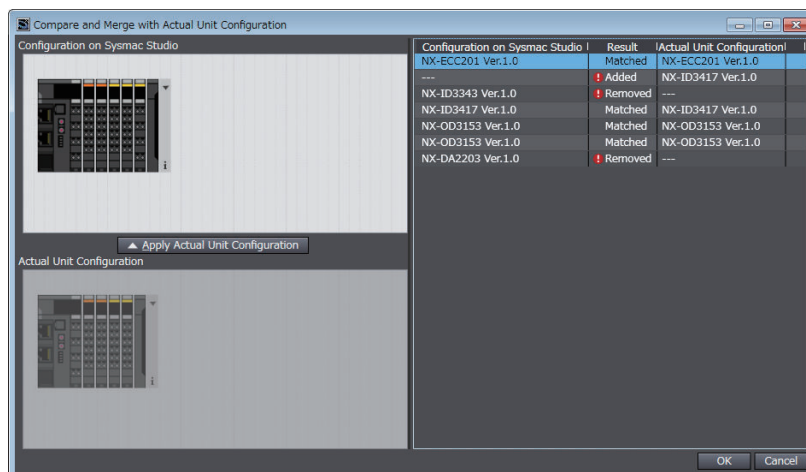

- 2 To merge with actual Unit configuration, click the **Apply Actual Unit Configuration** Button. The configuration information on the Sysmac Studio will now match the actual Unit configuration.
- 3 Click the **OK** Button.  
The display returns to the Edit Slave Terminal Configuration Tab Page.



### Precautions for Safe Use

Check the user program, data, and parameter settings for proper execution before you use them for actual operation.



### Precautions for Correct Use

You can read only the Unit configuration in the Slave Terminal by comparing and merging with the actual Unit configuration. You cannot read the I/O allocation information, Unit operation settings, and Unit application data.

## Getting NX Unit Serial Numbers

If the **serial number check method** that is set in the EtherCAT Coupler Unit is set to **Setting = Actual device**, you must download the Unit configuration information in which the serial numbers for the NX Units are set to the EtherCAT Coupler Unit. Use the following procedure to apply the serial numbers of the actual devices to the serial numbers of the NX Units in the Unit configuration information on the Sysmac Studio. Refer to *9-2-3 Setting the Unit Configuration Information* on page 9-10 for information on checking serial numbers.

- 1 Go online, right-click anywhere in the Edit Slave Terminal Configuration Tab Page, and select **Get Serial Numbers of All NX Units**.

An execution confirmation dialog box is displayed.

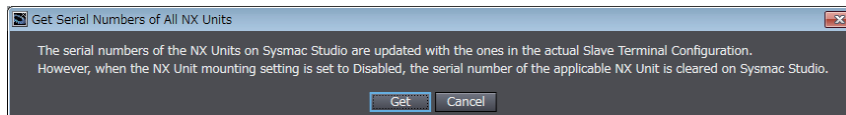

- 2 Click the **Get** Button.

The serial numbers are read from the actual Unit configuration, and applied to the Units in the configuration information for the Slave Terminal on the Sysmac Studio.

## Exporting/Importing Slave Terminal Settings and NX Unit Settings

You can export and import the Slave Terminal settings and NX Unit settings as files.

This procedure is not used to export and import data for the Safety Control Units. Refer to the *NX-series Safety Control Unit User's Manual (Cat. No. Z930)* for information on exporting/importing data from/to the Safety Control Units.

### ● Exporting/Importing Settings for the EtherCAT Coupler Unit as an Ether-CAT Slave

On the EtherCAT Configuration Edit Tab Page, you can export all of the Slave Terminal settings, shown below, into a single file (extension .ets).

The exported Slave Terminal setting file can be imported to add another Slave Terminal with the same settings. To do this, go into the EtherCAT Configuration Edit Tab Page in the same project or a new project on the Sysmac Studio.

- 1 On the EtherCAT Configuration Edit Tab Page, right-click the EtherCAT Coupler Unit and select **Export Slave Settings**.  
The **Save File** Dialog Box is displayed.

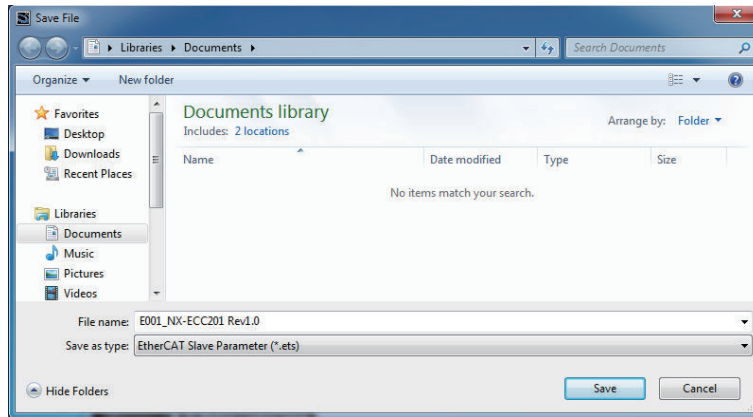

- 2 Enter a file name, and then click the **Save** Button.  
An EtherCAT slave parameter file with an .ets extension is saved.

To import a file, select **Import Slave Settings and Insert New Slave** in step 1, and specify the file to import.

## ● Exporting/Importing NX Unit Settings

On the Edit Slave Terminal Configuration Tab Page, you can export the Unit operating settings and Unit application data for each NX Unit into a single file (extension .nsf).

The exported NX Unit setting file can be imported to add other NX Units with the same settings. To do this, go into the Edit Slave Terminal Configuration Tab Page in a new project or the same project on the Sysmac Studio.

- 1 On the Edit Slave Terminal Configuration Tab Page, right-click the NX Unit to export and select **Export NX Unit Settings**.  
The **Export NX Unit Settings** Dialog Box is displayed.

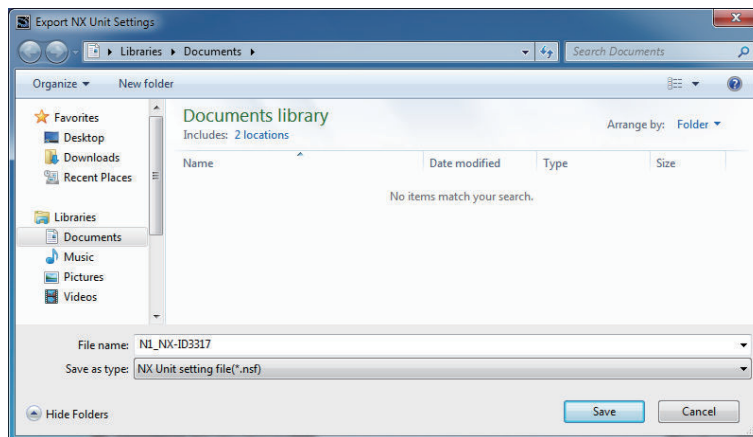

- 2 Enter a file name, and then click the **Save** Button.  
An NX Unit setting file with an .nsf extension is saved.

To import a file, select **Import NX Unit Settings and Insert New Unit** in step 1, and specify the file to import.

## Uploading Slave Terminal Settings through the USB Port on the EtherCAT Coupler Unit

You can connect the Sysmac Studio to the USB port on the EtherCAT Coupler Unit, and transfer the Slave Terminal settings information to the Sysmac Studio from the Slave Terminal. However, if Safety Control Units are mounted to more than one Slave Terminal, there are restrictions in the order that you can upload the settings. Refer to the *NX-series Safety Control Unit User's Manual (Cat. No. Z930)* for the restrictions.

Use the following procedure to upload the settings.

- 1 Connect the Sysmac Studio to the peripheral USB port on the EtherCAT Coupler Unit and place it online.
- 2 Right-click the EtherCAT Coupler Unit in the Edit Slave Terminal Configuration Tab Page, and select **Coupler Connection (USB) – Transfer from Coupler**.  
An execution confirmation dialog box is displayed.

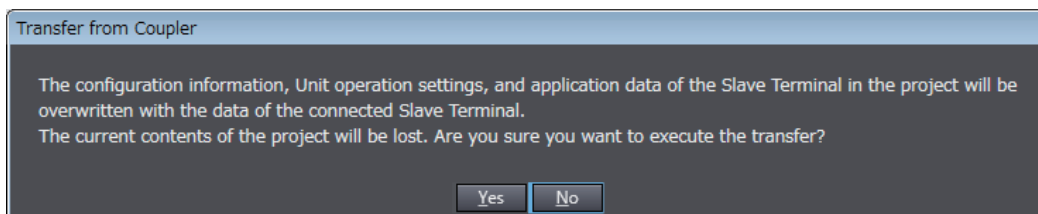

- 3 Click the **Yes** Button.  
The *configuration information*, *Unit operation settings*, and *Unit application data* of the Slave Terminal setting information are transferred.

## Changing the Model of an EtherCAT Coupler Unit or NX Unit

Use the following procedures to change the model or unit version of an EtherCAT Coupler Unit or NX Unit that is already registered in a project on the Sysmac Studio. You can use this function when you change a Unit to a Unit with a higher unit version.

### ● Changing the Model of an EtherCAT Coupler Unit

Use the EtherCAT Configuration Edit Tab Page to change the model of an EtherCAT Coupler Unit.

- 1 Right-click the EtherCAT Coupler Unit on the EtherCAT Configuration Edit Tab Page and select **Change Model**.  
The Units that you can change to are displayed in the Change Model Dialog Box.

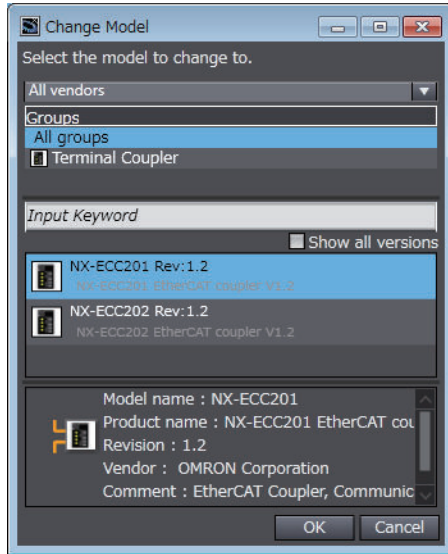

- 2 Select the Unit to change to and then click the **OK** Button.  
The Unit is changed to the selected model and unit version.



#### Precautions for Safe Use

Check the user program, data, and parameter settings for proper execution before you use them for actual operation.



#### Precautions for Correct Use

- If the unit version that you changed to is old and mounting an NX Unit registered in the Slave Terminal is not supported by the Sysmac Studio, an unsupported Unit error occurs for the NX Unit. Confirm that the model of the EtherCAT Coupler Unit after the change supports the NX Units on the Slave Terminal before you change the model. Refer to *A-11-2 Functions That Were Added or Changed for Each Unit Version* on page A-103 for the NX Units that are supported by EtherCAT Coupler Units.
- Any settings in the EtherCAT Coupler Unit before the change that are not supported by the EtherCAT Coupler Unit after the change will be lost when you change the model.
- If the performance of the EtherCAT Coupler Unit is different after changing the model, the timing of I/O may change.

### ● Changing NX Unit Models

Change the model of an NX Unit on the Edit Slave Terminal Configuration Tab Page on the Sysmac Studio.

- 1 Right-click the Unit to change on the Edit Slave Terminal Configuration Tab Page and select **Change Model**.  
The Units that you can change to are displayed in the Change Model Dialog Box.

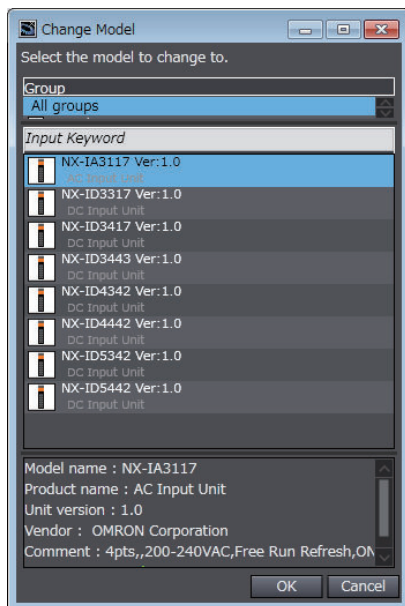

- 2 Select the Unit to change to and then click the **OK** Button.  
The Unit is changed to the selected model and unit version.



#### Precautions for Safe Use

Check the user program, data, and parameter settings for proper execution before you use them for actual operation.



#### Precautions for Correct Use

- If you change the model of an NX Unit that is assigned to an axis, the assignment to the axis is deleted. If necessary, assign the NX Unit to the axis again.
- Any settings in the NX Unit before the change that are not supported by the NX Unit after the change will be lost when you change the model.
- If the performance of the NX Unit is different after changing the model, the timing of I/O may change.

## Displaying the Transmission Delay Times of the EtherCAT Master

You can display the calculated values of the transmission delay times for the built-in EtherCAT port on an NX-series CPU Unit or NY-series Industrial PC. Always use this function in the calculation of the I/O response time when I/O refreshing for an EtherCAT Slave Terminal is performed in the priority-5 periodic task.

Use the following procedure to display the transmission delay times.

- 1 On the EtherCAT Configuration Edit Tab Page, right-click the EtherCAT master or an EtherCAT slave and select **Calculate Transmission Delay Time of the Master**.

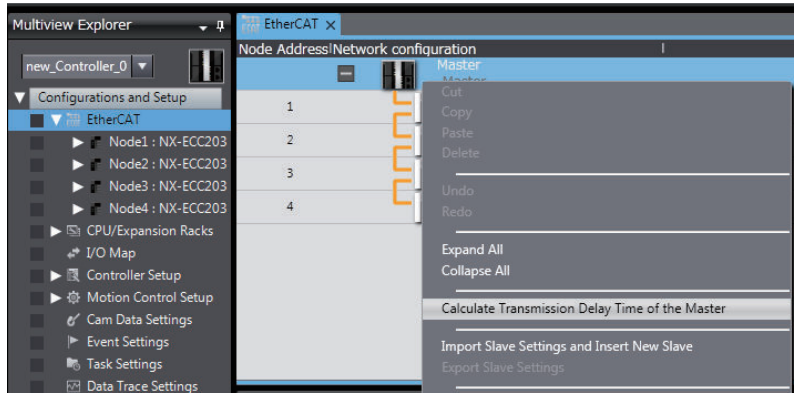

- 2 The transmission delay times of PDO communications cycle 1 and PDO communications cycle 2 are displayed in the Output Tab Page.

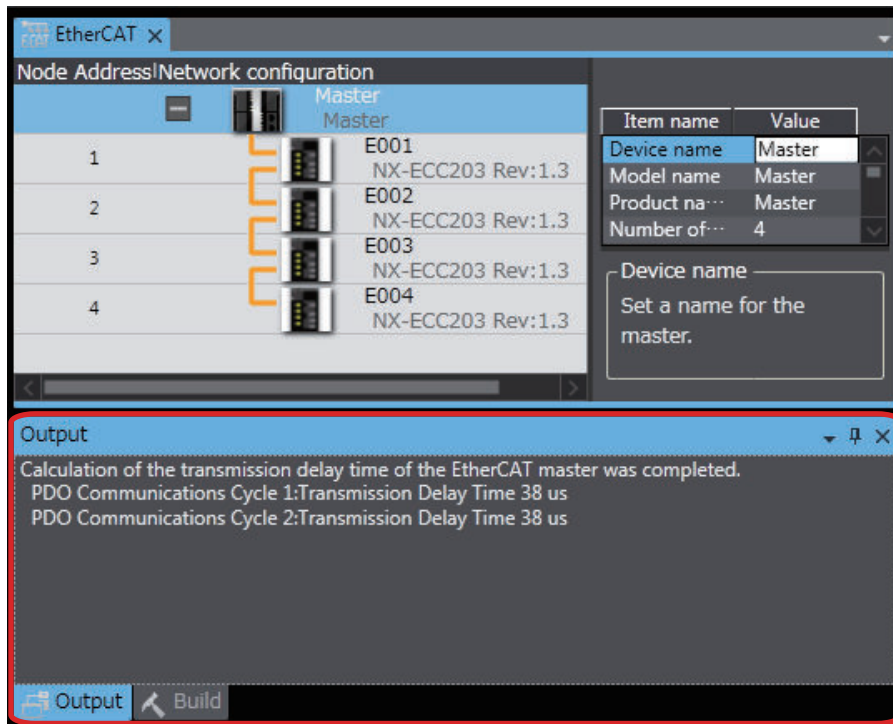

The transmission delay times of the EtherCAT master depend on the periodic tasks that are used in the CPU Unit or Industrial PC to refresh I/O for the EtherCAT Slave terminals, as shown below.

CPU Unit or Industrial PC periodic task in which I/O is refreshed	Applicable transmission delay time of the EtherCAT master
Primary periodic task	PDO communications cycle 1: Transmission delay time
Priority-5 periodic task*1	PDO communications cycle 2: Transmission delay time

\*1. The connected CPU Unit or Industrial PC must support a priority-5 periodic task. For example, NX701 CPU Units support them. Refer to *Assignment and Settings Related to Tasks* in the software user's manual for the connected CPU Unit or Industrial PC for information on the periodic tasks that are supported by the CPU Unit or Industrial PC.



### **Precautions for Correct Use**

---

The Sysmac Studio calculates the transmission delay times of the EtherCAT master based on the configuration information, such as the number of EtherCAT slaves and the EtherCAT frame lengths. Therefore, display the transmission delay times again if you change the EtherCAT configuration, EtherCAT setup, or Slave Terminal configuration.

---



### **Additional Information**

---

You cannot select this menu command if there is an error in the EtherCAT configurations and setup.

---

## 9-3 Assigning Variables

This section describes how to assign variables in the NJ/NX-series CPU Unit or NY-series Industrial PC to the I/O data in the EtherCAT Slave Terminal.

### 9-3-1 Methods to Assign Variables

The methods that are used to assign variables in the NJ/NX-series CPU Unit or NY-series Industrial PC to I/O data in the Slave Terminal are given below.

Method to assign variables	Description	Assignable Units
Assigning device variables	Assign device variables to the I/O ports of the Slave Terminal.	<ul style="list-style-type: none"> <li>• EtherCAT Coupler Unit</li> <li>• NX Units with I/O ports</li> </ul>
Assigning axis variables	Assign axis variables to the I/O data for the devices in the Slave Terminal. Assign axis variables if you are using the Motion Control Function Module for control.	<ul style="list-style-type: none"> <li>• Position Interface Units</li> <li>• Some other NX Units*<sup>1</sup></li> </ul>

\*1. Refer to the manuals for the specific NX Units to see which NX Units you can assign to axes.

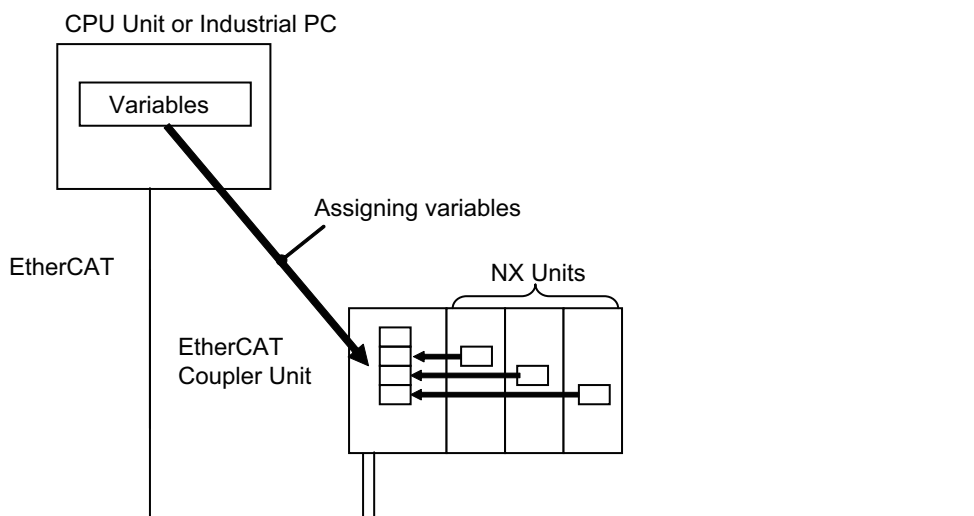

#### Version Information

With the Sysmac Studio version 1.09 or higher, device variables can be assigned to the I/O ports of NX Units to which a servo axis or encoder axis is assigned.

The I/O port to which a device variable can be assigned must meet either of the following conditions.

- The value of the R/W attribute is R (Read only).
- The value of the R/W attribute is W (Write only), and <Not assigned> is set for the process data field under **Detailed Settings** on the **Axis Basic Settings** Display in the Sysmac Studio.



### Precautions for Correct Use

If you perform the following steps, the system will clear the assignment of the device variables to the I/O ports of an NX Unit to which a servo axis or encoder axis is assigned.

1. With the Sysmac Studio version 1.09 or higher, assign device variables to the I/O ports of the NX Units to which axes are assigned.
2. Save the project data.
3. Open the saved project data with the Sysmac Studio version 1.08 or lower.

## 9-3-2 Assigning Device Variables to I/O Ports

When you create the Unit configuration information, the I/O data that are assigned in the EtherCAT Slave Terminal are displayed as I/O ports.

To access the EtherCAT Slave Terminal, assign device variables to the I/O ports and reference the device variables in the user program.

For details on I/O ports and device variables, refer to the software user's manual for the connected CPU Unit or Industrial PC.

## Checking I/O Ports

You can check the I/O ports with the *I/O Map* on the Sysmac Studio.

Select **I/O Map** under **Configurations and Setup** on the Multiview Explorer on the Sysmac Studio

Position	Port	Description	R/W	Data Type	Variable	Variable Comment
EtherCAT	Master					
Node1	R88D-KN01H-ECT					
Node2	R88D-KN01H-ECT					
Node3	R88D-KN01H-ECT					
Node4	R88D-KN01H-ECT					
Node5	NX-ECC201					
	▼ Sysmac Error Status					
	Sysmac error st	Sysmac error st	R	BYTE	E005_Sysmac_Error_Status	
	Observation	Observation	R	BOOL	E005_Observation	
	Minor Fault	Minor fault	R	BOOL	E005_Minor_Fault	
	Partial Fault	Partial fault	R	BOOL	E005_Partial_Fault	
	Major Fault	Major fault	R	BOOL	E005_Major_Fault	
	NX Unit Registration Status 125	Status whether	R	ARRAY[0..125] OF BOOL	E005_NX_Unit_Registration_Status_125	
	NX Unit I/O Data Active Status 125	Status whether	R	ARRAY[0..125] OF BOOL	E005_NX_Unit_I_O_Data_Active_Status_125	
Unit1	▼ NX-ID3317					
	Input Bit 00	Input Bit 00	R	BOOL	N1_Input_Bit_00	
	Input Bit 01	Input Bit 01	R	BOOL	N1_Input_Bit_01	
	Input Bit 02	Input Bit 02	R	BOOL	N1_Input_Bit_02	
	Input Bit 03	Input Bit 03	R	BOOL	N1_Input_Bit_03	
	▼ CPU/Expansion Racks					
CPU Rack	CPU Rack 0					

## I/O Port Names

### ● I/O Port Names for the EtherCAT Coupler Unit

Refer to *Allocatable I/O Data in an EtherCAT Coupler Unit* on page 9-16 under *9-2-4 I/O Allocation Information* on page 9-15 for details on the I/O port names in the EtherCAT Coupler Unit.

### ● I/O Port Names for the NX Units

Refer to the manual for the specific Unit for the I/O port names in NX Units.

The following is an example for a Digital Input Unit (NX-ID3317 Four-point Input Unit).

Examples:

Input Bit 00 to Input Bit 03

## Registering Device Variables and Attributes

### ● Registering Device Variables

You assign device variables to I/O ports in the I/O Map of the Sysmac Studio. The device variables that you create are registered in the variable table.

### ● Device Variable Attributes

This section describes the attributes for the device variables that are used with the EtherCAT Slave Terminal.

Attribute	Specification method	Changes to settings
Variable name	There are three ways to assign a device variable. <ul style="list-style-type: none"> <li>• Select a registered variable from the variable table.</li> <li>• Manually enter the device variable name.</li> <li>• Automatically create the device variable name.</li> </ul> Variable names are automatically created using the following convention: device_name+I/O_port_name	Possible.
Data type	You must specify a data type of the same size as the data type of the <i>I/O port</i> .	Possible.*1
AT specification	ECAT://node#[node_address.NX_Unit_number]/I/O_port_name Examples: For an EtherCAT Coupler Unit whose node address is 10, and a Digital Input Unit (NX-ID3317 Four-point Input Unit) whose NX Unit number is 15: ECAT://node#[10,15]/Input Bit 00 to ECAT://node#[10,15]/Input Bit 03	Not possible.
Retain	Not retained.	Not possible.
Initial value	None	Possible.
Constant	Do not specify a constant.	Possible.
Network publish	Do not publish.	Possible.

\*1. Changes are possible only for data types of the same size.

## 9-3-3 I/O Ports for Status That Accept Device Variable Assignments

### I/O Ports for Status

To access the status of the EtherCAT Slave Terminal from the user program in the NJ/NX-series CPU Unit or NY-series Industrial PC, assign device variables to the I/O ports for the status.

Refer to *Allocatable I/O Data in an EtherCAT Coupler Unit* on page 9-16 under *9-2-4 I/O Allocation Information* on page 9-15 for the I/O ports that you can assign.

## Programming Sample Using I/O Ports for Status

### ● Testing the Validity of I/O Data for Individual Units

The *NX Unit I/O Data Active Status* and the *NX Unit Error Status* are assigned to the EtherCAT Coupler Unit.

The I/O data is manipulated in the NX Unit at NX Unit number 10 in the EtherCAT Coupler Unit with node address 5.

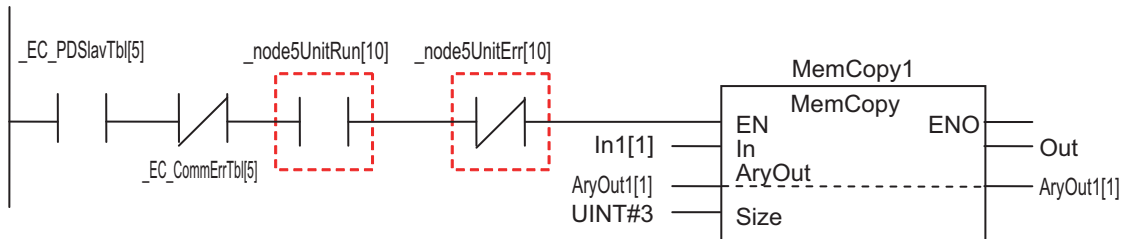

\* *\_node5UnitRun[10]*: This is a device variable for the EtherCAT Coupler Unit (with node address 5) to which the NX Unit I/O Data Active Status (NX Unit number 10) is assigned.

\* *\_node5UnitErr[10]*: This is a device variable for the EtherCAT Coupler Unit (with node address 5) to which the NX Unit Error Status (NX Unit number 10) is assigned.

### ● Testing Whether Individual NX Units Can Process Message Communications

To test whether a Unit can process message communications, assign the *NX Unit Message Enabled Status* to the EtherCAT Coupler Unit.

The Write NX Unit Object instruction is used to send a message to the NX Unit at NX Unit number 10 in the EtherCAT Coupler Unit with node address 5.

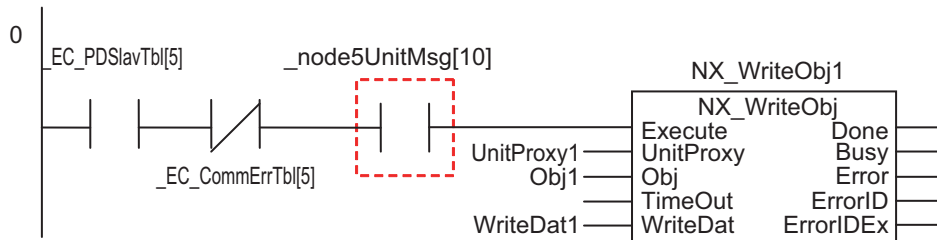

*\_node5UnitMsg[10]*: This is a device variable for the EtherCAT Coupler Unit (with node address 5) to which the NX Unit Message Enabled Status (NX Unit number 10) is assigned.



#### Additional Information

To use the built-in EtherCAT port on the NJ/NX-series CPU Unit or NY-series Industrial PC as the EtherCAT master to access the status of the EtherCAT Slave Terminal as an EtherCAT slave, use the system-defined variables in the EtherCAT Master Function Module. For details, refer to the user's manual for the built-in EtherCAT port on the connected CPU Unit or Industrial PC.

## 9-3-4 Assigning Axis Variables

To control NX Units, such as Position Interface Units, with the Motion Control Function Module, create axes on the Sysmac Studio, and assign system-defined variables called Axis Variables to the I/O data.

Refer to the *NX-series Position Interface Unit User's Manual (Cat. No. W524)* for instructions on using the Position Interface Units. Refer to the motion control user's manual for the connected CPU Unit or Industrial PC for information on using Axis Variables.



#### **Precautions for Correct Use**

---

If an axis variable is assigned to NX Unit I/O data, *enable* the *distributed clock* in the EtherCAT Coupler Unit where the NX Unit is mounted. If the *distributed clock* is *disabled*, an axis cannot be assigned to the NX Unit, so you cannot assign an axis variable to the NX Unit I/O data.

---

## 9-4 Transferring and Comparing Settings

This section describes how to transfer and compare EtherCAT Slave Terminal settings that you set on the Sysmac Studio.

This procedure is not used to transfer settings to the Safety Control Units. Refer to the *NX-series Safety Control Unit User's Manual (Cat. No. Z930)* for the procedure to transfer settings to the Safety Control Units.

### WARNING

Always confirm safety at the destination node before you transfer Unit configuration information, parameters, settings, or other data from tools such as the Sysmac Studio. The devices or machines may operate unexpectedly, regardless of the operating mode of the Controller.

### 9-4-1 Transferring Settings

This section describes how to transfer Slave Terminal settings and I/O allocation settings to the Controller.

#### Procedure to Transfer Settings

On the Sysmac Studio that is connected to an NJ/NX-series CPU Unit or NY-series Industrial PC, use the synchronization function of the Sysmac Studio to transfer all of the following data: *network configuration information, configuration information, Unit operation settings, and Unit application data.*

The actual operating procedure is given below.

- 1** Place the Sysmac Studio online with the CPU Unit or Industrial PC and execute synchronization.  
The comparison results are displayed in the Synchronization Pane.



**2** To transfer the Unit operation settings for the EtherCAT Slave Terminal and the application data for the NX Units, make the setting to transfer the *Slave Terminal Unit operation settings and NX Unit application data* in the Synchronization Pane.

For example, when using an NJ-series CPU Unit, clear the selection of the following check box.

Do not transfer the following. (All items are not transferred.)

- CJ-series Special Unit parameters and EtherCAT slave backup parameters
- Slave Terminal Unit operation settings and NX Unit application data

Example: NJ-series CPU Unit

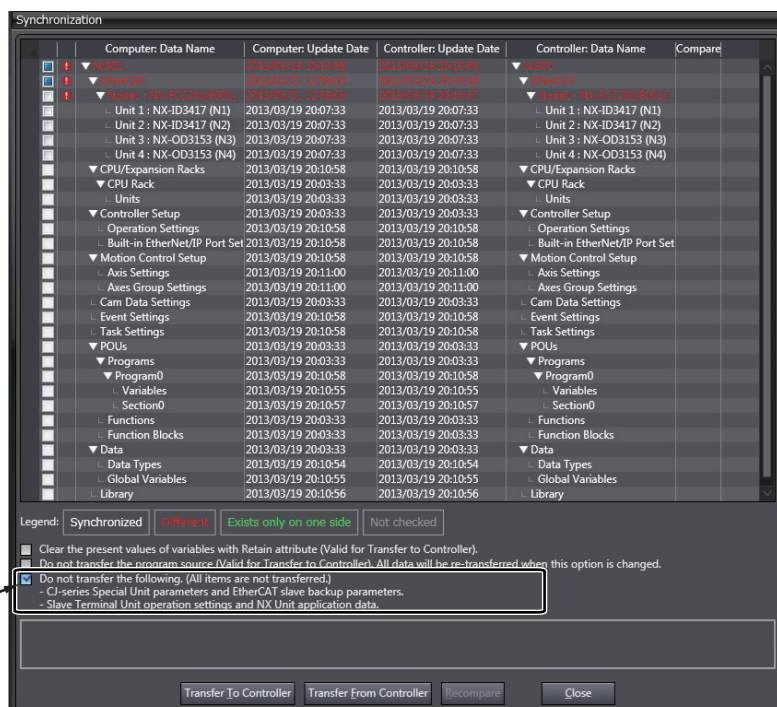

Clear the selection of this check box. It is selected in this screen capture.

For items other than the *Slave Terminal Unit operation settings and NX Unit application data*, the check box text may vary with the CPU Unit or Industrial PC that is used.

- 3** From the Comparison Results Dialog Box, select the EtherCAT Slave Terminal as a transfer item, and then click the **Transfer To Controller** Button.  
An execution confirmation dialog box is displayed.
- 4** Click the **Yes** Button.  
The settings are transferred from the Sysmac Studio to the EtherCAT Coupler Unit so that they match. When the transfer is completed, the Slave Terminal is restarted.

Before the transfer begins, you can run a check on the Sysmac Studio to see if the configuration data is the same. This will compare the EtherCAT network configuration and the Unit configuration for the EtherCAT Slave Terminal, which were created offline, with the actual configuration of the EtherCAT network and the Units in the EtherCAT Slave Terminal.

Refer to *Comparing and Merging with Actual Unit Configuration of the Slave Terminal* on page 9-29 under *9-2-7 Sysmac Studio Functions Used as Required* on page 9-28.



### Precautions for Correct Use

---

- If the comparison is done with the Sysmac Studio connected and synchronized with the CPU Unit or Industrial PC, you cannot compare the settings that are downloaded to the EtherCAT Slave Terminal. Refer to *9-4-2 Comparing Settings* on page 9-45 to compare the EtherCAT Slave Terminal settings.
  - In the following cases, the EtherCAT Slave Terminal is restarted after the transfer is completed: when the transfer is done without using the synchronization function of the Sysmac Studio through the NJ/NX-series CPU Unit or through the NY-series Industrial PC or when the Sysmac Studio is connected to the USB port on the EtherCAT Coupler Unit. The restart may cause the EtherCAT master to detect an error. In this case, you must reset the error on the EtherCAT master.
  - When the Slave Terminal is restarted, all of the Units on the Slave Terminal perform the same operation as when the power supply is cycled. Refer to the manuals for the specific Units for the operation that is performed when the power supply is turned ON.
- 



### Additional Information

---

- You can connect the Sysmac Studio to the USB port on the EtherCAT Coupler Unit to transfer the Slave Terminal parameter settings to the Slave Terminal. In this case, you cannot transfer the CPU Unit user program and other data. In this case, you cannot transfer the CPU Unit or Industrial PC user program and other data.
  - Refer to *A-2-3 Transferring Slave Terminal Setting Information through the USB Port on the EtherCAT Coupler Unit* on page A-8 for the transfer procedure.
  - You can also transfer only the *Unit operation settings* to the EtherCAT Coupler Unit and NX Units without using the synchronization function of the Sysmac Studio. In this case, the settings are transferred to one Unit at a time. Refer to *A-2-2 Transferring the Unit Operation Settings* on page A-6 for details.
-

## 9-4-2 Comparing Settings

To compare the EtherCAT Slave Terminal settings, connect the Sysmac Studio to the USB port of the EtherCAT Coupler Unit to compare. Use the following procedure.

Refer to *Comparing and Merging with Actual Unit Configuration of the Slave Terminal* on page 9-29 under *9-2-7 Sysmac Studio Functions Used as Required* on page 9-28 to compare the Unit configuration.

- 1** Connect the Sysmac Studio to the USB port on the EtherCAT Coupler Unit.
- 2** In the Unit Settings Pane on the *Edit Slave Terminal Configuration Tab Page*, click the **Online** Button next to **Coupler Connection (USB)** for the target EtherCAT Coupler Unit. An execution confirmation dialog box is displayed.
- 3** Click the **OK** Button. The Sysmac Studio goes online with the EtherCAT Slave Terminal.
- 4** Right-click the target EtherCAT Coupler Unit and select **Coupler Connection (USB) – Compare** from the pop-up menu. The results of the comparison are displayed as shown below.

When the Settings Are the Same:

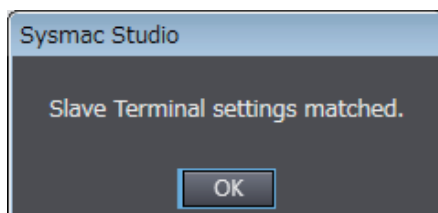

When the Settings Are Different:

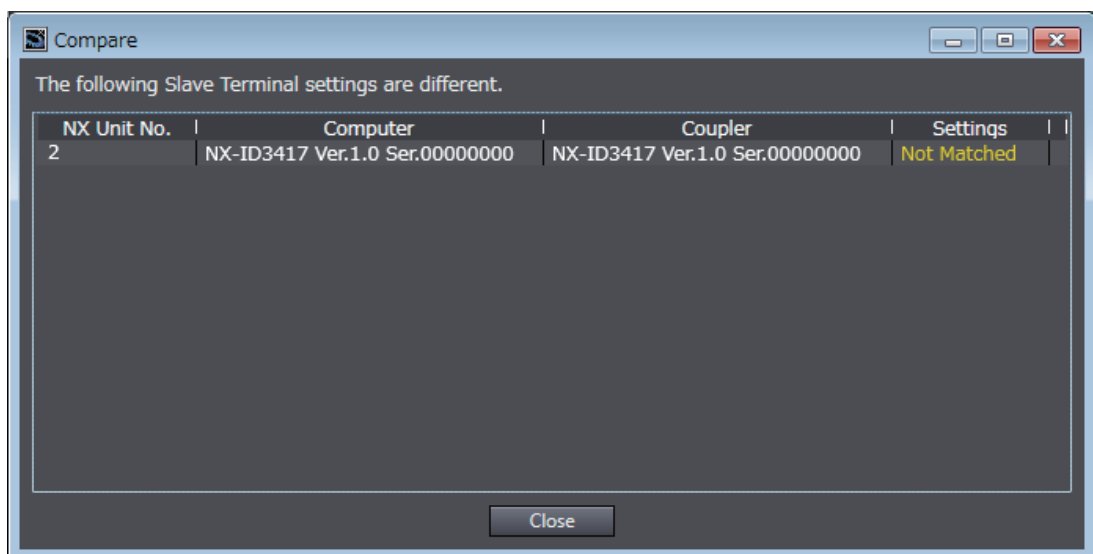



### **Precautions for Correct Use**

---

You cannot compare the EtherCAT Slave Terminal settings if you connect the Sysmac Studio to the CPU Unit or Industrial PC.

---

## 9-5 Backing Up Settings

This section describes how to back up the Slave Terminal settings.

### 9-5-1 Backup Functions

You can back up, restore, and compare Slave Terminal settings with the backup functions for the entire NJ/NX/NY-series Controller. The backup functions are used when you need to replace hardware, or to change or restore various settings in a single operation.

However, the backup functions for the entire NJ/NX/NY-series Controller cannot be used for Safety Control Units.

For an NJ/NX-series CPU Unit, you can back up, restore, and compare the settings for the entire Slave Terminal, including the Communications Coupler Unit and NX Units, to either of these locations: an SD Memory Card inserted in the CPU Unit or a specified folder on a computer. With an NY-series Industrial PC, you can backup or compare the settings for the overall Slave Terminals to the Virtual SD Memory Card in the Industrial PC. Also, you can back up, restore, and compare the settings to settings in a designated folder on your computer.

The functions also backup all the other data in the Controller.

For details on backup functions, refer to the software user's manual for the connected CPU Unit or Industrial PC.

The following backup functions are supported.

Function name	Backing up data	Restoring data	Comparing data
SD Memory Card backup function* <sup>1</sup>	Yes	<ul style="list-style-type: none"> <li>CPU Unit: Yes</li> <li>Industrial PC: No*<sup>2</sup></li> </ul>	Yes
Sysmac Studio Controller backup function	Yes	Yes	Yes

\*1. The SD Memory Card backup functions of the Industrial PC back up and verify data in the Virtual SD Memory Card.

\*2. For the methods to restore backup files saved to the Virtual SD Memory Card, refer to the software user's manual of the Industrial PC.

### 9-5-2 SD Memory Card Backup Function

You can back up, restore, and compare the data for the entire NJ/NX-series Controller (including the Slave Terminals) to an SD Memory Card that is inserted in the NJ/NX-series CPU Unit. With an NY-series Industrial PC, you then can back up and compare the data for the entire NY-series Controller (including the Slave Terminals) with the Virtual SD Memory Card in the Industrial PC.

For details on SD Memory Card backup, refer to the software user's manual for the connected CPU Unit or Industrial PC.

### 9-5-3 Sysmac Studio Controller Backup Function

You can back up, restore, and compare the data for the entire NJ/NX-series Controller (including Slave Terminals) from the Sysmac Studio that is online with the NJ/NX-series CPU Unit. With an NY-series Industrial PC, you can back up, restore, and compare the data for the entire NY-series Controller from the Sysmac Studio that is online with the NJ/NX-series CPU Unit.

For details on Sysmac Studio Controller backups, refer to the software user's manual for the connected CPU Unit or Industrial PC.



#### Precautions for Correct Use

This function is not supported if the Sysmac Studio is connected directly to the USB port on the EtherCAT Coupler Unit.



#### Additional Information

##### Importing Sysmac Studio Backup Files

On the Sysmac Studio, you can import backup files that were saved with the Controller backup function, which includes all of the Slave Terminal data, into a project.

For details on target data for Sysmac Studio backup importing, refer to the software user's manual for the connected CPU Unit or Industrial PC. Refer to the *Sysmac Studio Version 1 Operation Manual (Cat. No. W504)* for the procedure to import backup files.

### 9-5-4 Data That Is Backed Up

The following data for Slave Terminal setting is backed up, restored, or compared.

This data is saved in the *backup file* along with the other target data in the Controller.

OK: Included, NA: Excluded

Unit	Data	Backing up data	Restoring data	Comparing data
EtherCAT Coupler Unit	Configuration information	OK	OK	OK
	Unit operation settings	OK	OK	OK
NX Units	Configuration information	OK	OK	OK
	Unit operation settings	OK	OK	OK
	Unit application data <sup>*1</sup>	OK	OK	OK

\*1. This data is only included if the Unit has Unit application data.



#### Precautions for Correct Use

To restore backup data to an EtherCAT Slave Terminal that has an identical Unit configuration, make sure all hardware switches are set to the same settings as when the backup was made. Backup data cannot be restored if the hardware switches are set differently from those in the backup data. This will cause an *Restore Operation Failed to Start (EtherCAT Slave)* observation event to occur.

### 9-5-5 Backing Up the Slave Terminal Settings by Transferring Data

To back up only the Slave Terminal settings rather than the entire Controller data, use the synchronization function of the Sysmac Studio. Transfer only the Slave Terminal settings to the computer, apply them to the project, and save the project.

The actual operating procedure is given below.

- 1 Place the Sysmac Studio online with the CPU Unit or Industrial PC and execute synchronization.

The comparison results are displayed in the Synchronization Pane.

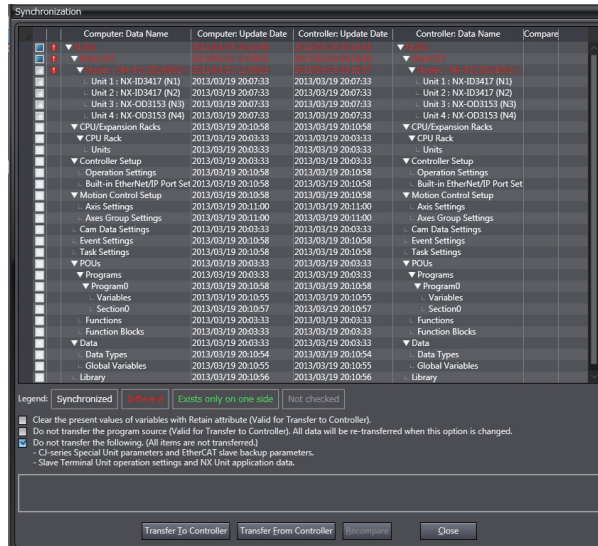

- 2 To transfer the Unit operation settings for the EtherCAT Slave Terminal and the application data for the NX Units, make the setting to transfer the *Slave Terminal Unit operation settings and NX Unit application data* in the Synchronization Pane.

For example, when using an NJ-series CPU Unit, clear the selection of the following check box.

Do not transfer the following. (All items are not transferred.)

- CJ-series Special Unit parameters and EtherCAT slave backup parameters
- Slave Terminal Unit operation settings and NX Unit application data

Example: NJ-series CPU Unit

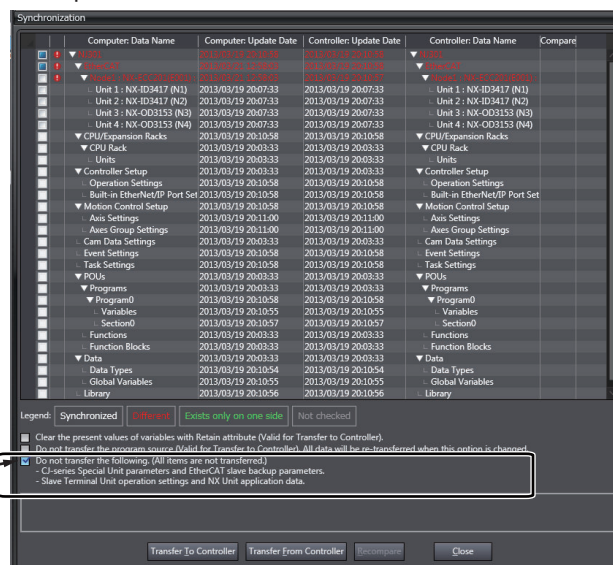

Clear the selection of this check box. It is selected in this screen capture.

For items other than the *Slave Terminal Unit operation settings and NX Unit application data*, the check box text may vary with the CPU Unit or Industrial PC that is used.

- 3** From the Comparison Results Dialog Box, select the Communications Coupler Unit as the Transfer Item, and then click the **Transfer From Controller** Button.  
An execution confirmation dialog box is displayed.
- 4** Click the **Yes** Button.  
The settings are transferred from the EtherCAT Coupler Unit to the Sysmac Studio.
- 5** Close the Synchronization Window and save the project.

To restore the backed up Slave Terminal settings data, open the saved project file on the Sysmac Studio and transfer the Slave Terminal settings to the Slave Terminal. Refer to *9-4-1 Transferring Settings* on page 9-42 for the procedure to transfer the settings to the Slave Terminal.



### **Precautions for Correct Use**

---

These functions are not supported if the Sysmac Studio is connected directly to the USB port on the EtherCAT Coupler Unit.

---

## 9-6 Precautions in Changing the Unit Configuration

This section provides precautions that apply when you change the Unit configuration of an EtherCAT Slave Terminal.

### 9-6-1 I/O Data That Require Specification of NX Unit Numbers

You must specify the NX Unit number to access some I/O data. If you change the Unit configuration of an EtherCAT Slave Terminal, you must correct the specified NX Unit numbers, such as those in programs.

The *NX Unit Registration Status* and *NX Unit Error Status* that are described in 9-2-4 *I/O Allocation Information* on page 9-15 are examples of I/O data that is accessed by specifying the NX Unit number. The I/O data for this status information uses BOOL arrays, and the NX Unit number is specified as the subscript.

For example, if an NX Unit (F in the bottom figure) is added to the Slave Terminal, the NX Unit numbers of all NX Units to the right of the new NX Unit (C to E in the bottom figure) will change.

NX Unit number	1	2	3	4	5
NX Unit Registration Status	NxReg[1]	NxReg[2]	NxReg[3]	NxReg[4]	NxReg[5]

EtherCAT Coupler Unit	NX Unit A	NX Unit B	NX Unit C	NX Unit D	NX Unit E
-----------------------	-----------	-----------	-----------	-----------	-----------

NX Unit F added as 3rd NX Unit  The addition changes the NX Unit numbers, so you must correct the subscripts to specify the same NX Units as before the addition in the NX Unit Registration Status.

	1	2	3	4	5	6
	NxReg[1]	NxReg[2]	NxReg[3]	NxReg[4]	NxReg[5]	NxReg[6]
EtherCAT Coupler Unit	NX Unit A	NX Unit B	NX Unit F	NX Unit C	NX Unit D	NX Unit E

Note: *NxReg[ ]* is the variable that is assigned to the NX Unit Registration Status.

If you specify the subscripts of arrays directly with numbers, the subscripts in the program must be corrected to specify the same NX Unit as before the addition.

If you use `_sNXUNIT_ID` data type variables that are assigned to the Units to specify the array subscripts, you do not need to correct the program even if the Unit configuration changes. The NX Unit number of a Unit is stored in the `UnitNo` member of the `_sNXUNIT_ID` structure variable.

For example, if the `_sNXUNIT_ID` variable `NXUnitC` is assigned to NX Unit C in the above figure, the program would not need to be corrected even if the Unit configuration changed as long as the array subscript is specified with `NxReg[NXUnitC.UnitNo]`.

For information on how to register variables to assign to Units and how to assign variables, refer to *Allocating Variables to Units* in the software user's manual for the connected CPU Unit or Industrial PC.



### Additional Information

#### NX Unit Mounting Settings

If an NX Unit is removed or if you know in advance that an NX Unit is planned to be added, you can use the NX Unit mounting settings to prevent the NX Unit numbers from changing.

Refer to *11-2 NX Unit Mounting Settings* on page 11-6 for details on the NX Unit mounting settings.

## 9-6-2 NX Bus Refresh Cycle in DC Mode

When you use EtherCAT Slave Terminals in DC Mode, the NX bus refresh cycles for all other Slave Terminals will increase if the NX bus refresh cycle for any one Slave Terminal increases.

The NX bus refresh cycle of a Slave Terminal increases in the following cases.

- If you add an NX Unit with a long refresh cycle to the Slave Terminal when synchronous I/O refreshing is set for operation, the NX bus refresh cycles will increase.
- If the number of NX Units mounted to a Slave Terminal increases, the amount of data communications increases and the data processing time of the Slave Terminal becomes longer. Therefore, the NX bus refresh cycles become longer.

You can use the following measures to eliminate the influences of the refresh cycle between NX Units on the same Slave Terminal and between different Slave Terminals. Implementing these countermeasures may affect the communications performance and require changes in the programming. Consider the results of these measures carefully before you implement them.

- Slave Terminals that do not require synchronization are set to Free-Run Mode so that they operate with Free-Run refreshing.
- If you use a built-in EtherCAT port that can perform process data communications with a Slave Terminal in more than one periodic task, assign the Slave Terminal to a separate periodic task that can perform process data communications. For example, if you use an NX701 CPU Unit, assign a Slave Terminal that was assigned to the primary periodic task to the priority-5 periodic task. However, if the task period of the periodic task to which you add the Slave Terminal does not have any leeway in respect to the NX bus refresh cycle, you may have to increase the task period.
- If an NX Unit supports both synchronous I/O refreshing and task period prioritized refreshing, set task period prioritized refreshing unless there is a specific need to use synchronous I/O refreshing.

Refer to *10-3-2 Setting the I/O Refreshing Methods* on page 10-9 for the setting procedure of the Slave Terminal I/O refreshing method. Refer to *10-3-6 Task Allocations* on page 10-22 for the method to allocate a Slave Terminal to a task.

### 9-6-3 Using Settings from NX Units on Other Slave Terminals

To mount and use NX Units that were set for one Slave Terminal under a different EtherCAT Coupler Unit, you must export and import NX Unit settings.

To use the NX Unit settings on a different Slave Terminal, you must export the NX Unit settings from the Unit configuration of the set Slave Terminal and then import the settings to the Unit configuration of the newly mounted Slave Terminal.



#### Additional Information

- Refer to *9-2-7 Sysmac Studio Functions Used as Required* on page 9-28 for information on exporting and importing NX Unit settings.
- Some of the NX Unit settings are saved in the EtherCAT Coupler Unit. Therefore, even if you upload the NX Unit settings to an NX Unit that was set on a different Slave Terminal, the original NX Unit settings are not correctly applied to the newly mounted Slave Terminal. If you want to use the set NX Unit by mounting it to another Slave Terminal, transfer the Unit operation settings to the relevant NX Unit.

### 9-6-4 Transferring Slave Terminal Setting Information to the Controller

When an EtherCAT Slave Terminal is connected to the built-in EtherCAT port on an NJ/NX-series CPU Unit or NY-series Industrial PC, the Slave Terminal setting information must be the same between the CPU Unit or Industrial PC and the EtherCAT Slave Terminal.

When you transfer the Slave Terminal setting information, always use the synchronization function from the Sysmac Studio that is connected to the CPU Unit or Industrial PC.

The Slave Terminal setting information transfer procedure given below is for when an EtherCAT Slave Terminal is connected to a built-in EtherCAT port and the actual Slave Terminal configuration was changed without changing the node address.

- 1** Connect the Sysmac Studio to the Slave Terminal through the CPU Unit or Industrial PC. Use the compare and merge with actual Unit configuration of Slave Terminal to synchronize the configuration information between the project and the actual Slave Terminal.
- 2** Set the Slave Terminal as an EtherCAT slave on the EtherCAT Configuration Edit Tab Page.
- 3** Set up the Slave Terminal (create the configuration and set the parameters) on the Edit Slave Terminal Configuration Tab Page.
- 4** On the I/O Map Tab Page, allocate variables and actual I/O.
- 5** Connect the Sysmac Studio to the CPU Unit or Industrial PC and use the synchronization function of the Sysmac Studio to transfer the Slave Terminal setting information.

If the node address was also changed, do the following before you perform step 1, above: Connect the Sysmac Studio to the Slave Terminal through the CPU Unit or Industrial PC, and use the compare and merge with actual network configuration of EtherCAT to synchronize the project and actual network configuration information.



# I/O Refreshing

This section describes I/O refreshing for EtherCAT Slave Terminals.

---

<b>10-1</b>	<b>Introduction to I/O Refreshing for EtherCAT Slave Terminals .....</b>	<b>10-2</b>
<b>10-2</b>	<b>I/O Refreshing for EtherCAT Slaves .....</b>	<b>10-6</b>
10-2-1	I/O Refreshing Modes .....	10-6
10-2-2	I/O Refreshing Mode Operation .....	10-6
<b>10-3</b>	<b>I/O Refreshing for EtherCAT Slave Terminals .....</b>	<b>10-8</b>
10-3-1	I/O Refreshing Methods .....	10-8
10-3-2	Setting the I/O Refreshing Methods .....	10-9
10-3-3	Selecting NX Units .....	10-10
10-3-4	I/O Refreshing Method Operation .....	10-10
10-3-5	Setting the Task Periods of Periodic Tasks .....	10-18
10-3-6	Task Allocations.....	10-22

# 10-1 Introduction to I/O Refreshing for EtherCAT Slave Terminals

This section introduces I/O refreshing for NX-series EtherCAT Slave Terminals.

The NJ/NX-series CPU Unit or NY-series Industrial PC performs I/O refreshing cyclically with the NX Units in an EtherCAT Slave Terminal through EtherCAT communications and the NX bus.

The following four cycles affect the operation of I/O refreshing between the NJ/NX-series CPU Unit or NY-series Industrial PC and the NX Units in an EtherCAT Slave Terminal.

(A) Task period of the periodic task in the CPU Unit or Industrial PC

(B) Process data communications cycle

(C) Refresh cycle of the NX bus

(D) Refresh cycle of each NX Unit

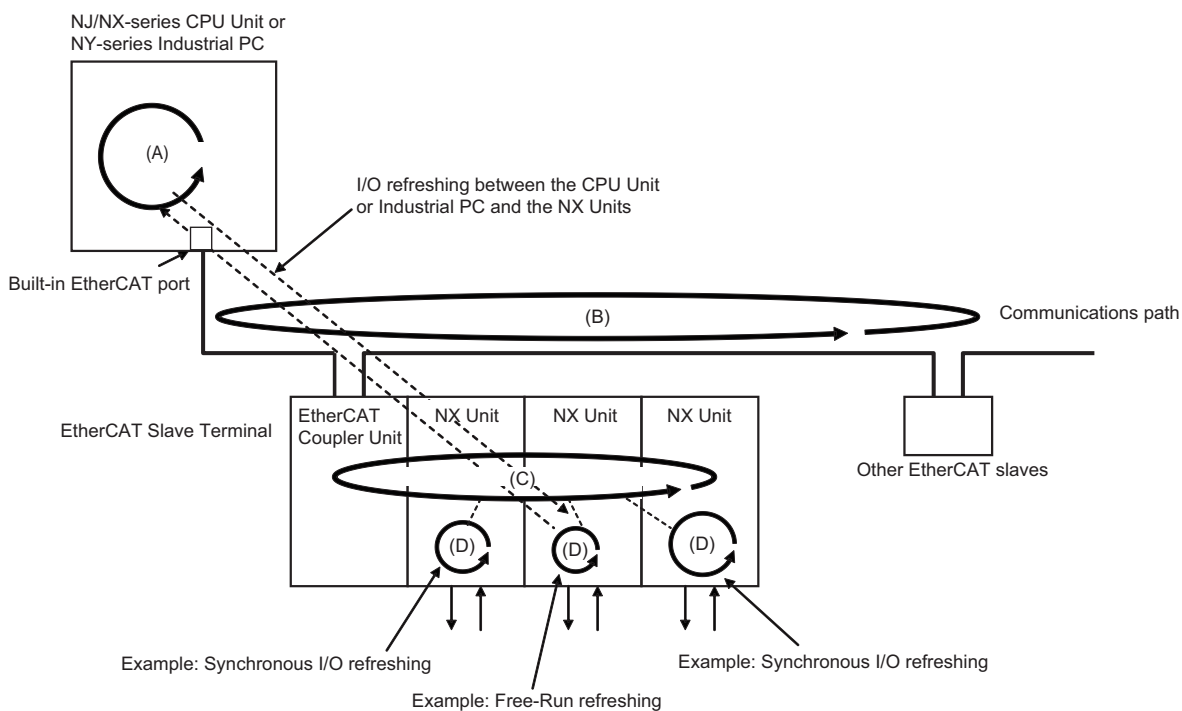

This section describes the operation of the NX Units on the EtherCAT Slave Terminals and the operation of I/O refreshing with the various series of CPU Units or Industrial PCs using the letters given in the above figure.

## I/O Refresh Operation with NX-series CPU Units

With the built-in EtherCAT port, some NX-series CPU Units can support process data communications with EtherCAT slaves and EtherCAT Slave Terminals in the primary periodic task and priority-5 periodic task, and others only in the primary periodic task.

This section describes how the I/O refreshing operates with the following CPU Units.

CPU Units	Periodic task which support process data communications
NX701 CPU Units	Primary periodic task and priority-5 periodic task
NX1P2 CPU Unit	Primary periodic task

For information on periodic tasks which support process data communications with the built-in EtherCAT port on the NX-series CPU Unit, refer to *Process Data Communications (PDO Communications)* in the *NJ/NX-series CPU Unit Built-in EtherCAT Port User's Manual (Cat. No. W505)*.

### ● CPU Units That Support Process Data Communications in Primary Periodic Task and Priority-5 Periodic Task

With the built-in EtherCAT port on an NX-series NX701 CPU Unit, you can perform process data communications with EtherCAT slaves and EtherCAT Slave Terminals in the primary periodic task and the priority-5 periodic task. Each of these periodic tasks has a process data communications cycle.

I/O refreshing operates as described below.

- The (B) process data communications cycle and (C) refresh cycle of the NX bus are automatically synchronized with the (A) task period of the periodic task in the CPU Unit.<sup>\*1</sup> The (B) and (C) that correspond to (A) are given in the following table.

\*1. This applies when the distributed clock is enabled in the EtherCAT Coupler Unit. Or, it applies when the task period of a periodic task is set to a value that is longer than the NX bus refresh cycle that was automatically calculated by the Sysmac Studio.

(A) Task period of the periodic task in the CPU Unit	(B) Process data communications cycle	(C) Refresh cycle of the NX bus
Task period of the primary periodic task (called the primary period)	Process data communications cycle 1	NX bus refresh cycle of the Slave Terminals that refresh I/O in the primary periodic task
Task period of the priority-5 periodic task	Process data communications cycle 2	NX bus refresh cycle of the Slave Terminals that refresh I/O in the priority-5 periodic task

The following is an example. In this example, EtherCAT Slave Terminal #1 is assigned to the primary periodic task and EtherCAT Slave Terminal #2 is assigned to the priority-5 periodic task. Process data communications cycle 1 and the refresh cycle of the NX bus for EtherCAT Slave Terminal #1 are automatically synchronized with the primary period. Process data communications cycle 2 and the refresh cycle of the NX bus for EtherCAT Slave Terminal #2 are automatically synchronized with the priority-5 periodic task.

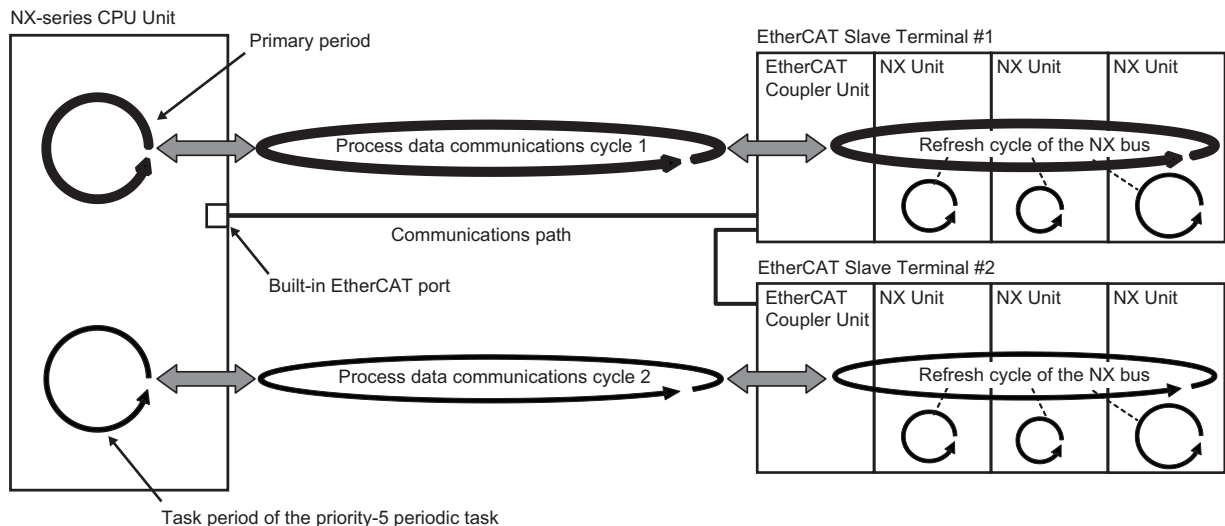

- The (D) refresh cycles of the NX Units depend on the I/O refreshing method of each NX Unit. You can also use NX Units with different I/O refreshing methods together. Refer to *10-3 I/O Refreshing for EtherCAT Slave Terminals* on page 10-8 for information on the I/O refreshing methods of each NX Unit.

### ● CPU Units That Support Process Data Communications Only in Primary Periodic Task

With the built-in EtherCAT port on an NX-series NX1P2 CPU Unit, you can perform process data communications with EtherCAT slaves and EtherCAT Slave Terminals in the primary periodic task.

The I/O refresh operation is the same as for an NJ-series CPU Unit or NY-series Industrial PC. For details on this operation, refer to *I/O Refresh Operation with NJ-series CPU Units or NY-series Industrial PCs* on page 10-4.

For the specifications of the built-in EtherCAT ports on NX-series CPU Units, refer to *Process Data Communications (PDO Communications) in the NJ/NX-series CPU Unit Built-in EtherCAT Port User's Manual (Cat. No. W505)*. For detailed task specifications of NX-series CPU Units, refer to *Designing Tasks in the NJ/NX-series CPU Unit Software User's Manual (Cat. No. W501)*. Refer to *10-3-6 Task Allocations* on page 10-22 for the method to allocate an EtherCAT Slave Terminal to a task.

## I/O Refresh Operation with NJ-series CPU Units or NY-series Industrial PCs

I/O refreshing operates as described below.

- The (B) process data communications cycle and (C) refresh cycle of the NX bus are automatically synchronized with the (A) task period of the primary periodic task in the CPU Unit or Industrial PC.\*<sup>1</sup>
- The (D) refresh cycles of the NX Units depend on the I/O refreshing method of each NX Unit. You can also use NX Units with different I/O refreshing methods together. Refer to *10-3 I/O Refreshing for EtherCAT Slave Terminals* on page 10-8 for information on the I/O refreshing methods of each NX Unit.

- \*1. This applies when the distributed clock is enabled in the EtherCAT Coupler Unit. Or, it applies when the task period of a periodic task is set to a value that is longer than the NX bus refresh cycle that was automatically calculated by the Sysmac Studio.

## I/O Refreshing Type

I/O refreshing is performed between the EtherCAT master and EtherCAT slaves and between the EtherCAT Coupler Unit and the NX Units. The ranges of refreshing are given in the following table.

Range	I/O refreshing type	
	Synchronized	Not synchronized
Refreshing between the EtherCAT master and EtherCAT slaves* <sup>1</sup>	DC Mode	Free-Run Mode
Refreshing between EtherCAT Coupler Unit and NX Units	<ul style="list-style-type: none"> <li>• Synchronous I/O refreshing</li> <li>• Time stamp refreshing</li> <li>• Task period prioritized refreshing</li> </ul>	Free-Run refreshing

- \*1. In this context, an EtherCAT Slave Terminal is an EtherCAT slave.

The operation of refreshing between the built-in EtherCAT port and the NX Units on the EtherCAT Slave Terminal is determined by the combination of the I/O refresh types for the above ranges.

The rest of this section gives a general description of I/O refreshing between the built-in EtherCAT port and EtherCAT slaves. This is followed by a description of I/O refreshing with the NX Units on EtherCAT Slave Terminals.

## 10-2 I/O Refreshing for EtherCAT Slaves

This section provides a general description of I/O refreshing between the built-in EtherCAT port on the NJ/NX-series CPU Unit or NY-series Industrial PC and the EtherCAT slaves.

### 10-2-1 I/O Refreshing Modes

The built-in EtherCAT port uses synchronization that is based on a distributed clock (DC) to process communications with EtherCAT slaves.

This type of synchronization uses a mechanism called a distributed clock for EtherCAT communications to synchronize each slave on the network.

EtherCAT slaves that support distributed clock synchronization have a clock that is shared by all slaves in the network.

Interruptions are generated in the slaves at precise intervals based on this clock. Each slave executes I/O processing based on the timing (Sync0) of these interruptions. The operating mode of slaves that operate in this manner is called *DC Mode*. The times for I/O refreshing that are based on the distributed clock are called the DC times.

Some slaves do not support the DC Mode. In that case, the process data communications cycle and the I/O cycle of the slaves operate asynchronously. The operation mode of slaves that operate in this manner is called *Free-Run Mode*.

The built-in EtherCAT port can execute I/O refreshing at the same time for slaves that operate in the *DC Mode* and slaves that operate in *Free-Run Mode*.

### 10-2-2 I/O Refreshing Mode Operation

This section describes the operation of I/O refreshing between the built-in EtherCAT port and EtherCAT slaves.

#### DC Mode Operation

*Synced slaves #1 and #2* in the figure labeled *Example of I/O Refreshing Mode Operation* on page 10-7 operate in *DC Mode*.

The inputs are read at a fixed interval for each slave based on Sync0. Because the performance levels of the slaves are different, inputs are not read at the same time across all of the slaves ((A) in the figure).

Each slave uses Sync0 as a trigger to perform output processing. Because the performance levels of the slaves are different, the processing results do not appear at the output terminals at the same time across all of the slaves ((B) in the figure).

## Free-Run Mode Operation

Free-run slave #3 in the figure labeled *Example of I/O Refreshing Mode Operation* on page 10-7 in *Free-Run Mode*.

This slave performs I/O processing based on its own unique timing ((C) and (D) in the figure), independent of Sync0.

## Example of I/O Refreshing Mode Operation

An example of operation in each I/O refreshing mode is provided in the following figure. The following figure is an example for the primary periodic task, but the same operation is performed with the priority-5 periodic task.

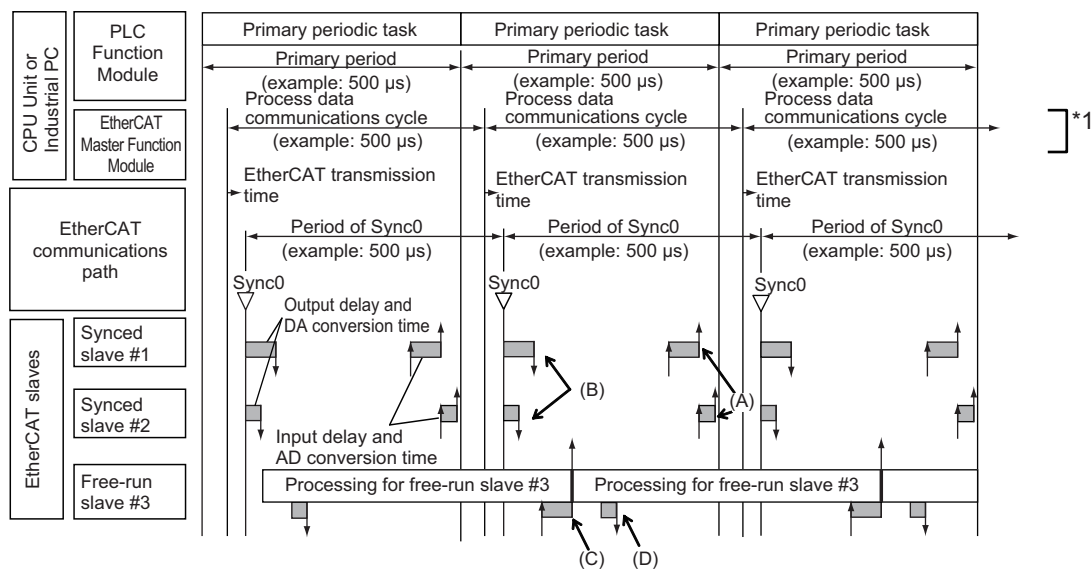

\*1. For a built-in EtherCAT port that can perform process data communications with a Slave Terminal in more than one periodic task, this is called process data communications cycle 1.

## 10-3 I/O Refreshing for EtherCAT Slave Terminals

This section describes I/O refreshing between the built-in EtherCAT port on the NJ/NX-series CPU Unit or NY-series Industrial PC and the EtherCAT Slave Terminals.

### 10-3-1 I/O Refreshing Methods

#### I/O Refreshing between the Built-in EtherCAT Port and the EtherCAT Coupler Unit

The EtherCAT Coupler Unit is an EtherCAT slave that supports DC synchronization.

The I/O refreshing between the built-in EtherCAT port and the EtherCAT Coupler Unit is the same as the operation of DC Mode that is described in *10-2 I/O Refreshing for EtherCAT Slaves* on page 10-6.

#### I/O Refreshing between the EtherCAT Coupler Unit and NX Units

There is more than one I/O refreshing method that you can use between the EtherCAT Coupler Unit and the NX Units.

The I/O refreshing methods that you can use between the EtherCAT Coupler Unit and the NX Units are listed below.

I/O refreshing method name	Outline of operation
Synchronous I/O refreshing	With this I/O refreshing method, the timing to read inputs or to refresh outputs is synchronized on a fixed interval between more than one NX Unit on more than one Slave Terminal.
Task period prioritized refreshing* <sup>1</sup>	With this I/O refreshing method, shortening the task period is given priority over synchronizing the I/O timing with other NX Units. With this I/O refreshing method, the timing of I/O is not consistent with the timing of I/O for NX Units that use synchronous I/O refreshing.
Input prioritized refreshing	With this refreshing method, execution of input processing is given priority over output processing. Output processing is executed after the completion of input processing.
Output prioritized refreshing	With this refreshing method, execution of output processing is given priority over input processing. Input processing is executed after the completion of output processing. The input data from input processing is read by the EtherCAT Coupler Unit in the next period after the period in which the output processing is performed.
Time stamp refreshing	With this I/O refreshing method, the NX Units record the DC times when inputs change or perform outputs at specified DC times. These times are asynchronous to the NX bus refresh cycles. Data exchange between the NX Units and EtherCAT Coupler Unit are performed cyclically on the NX bus refresh cycles.

I/O refreshing method name	Outline of operation
Input refreshing with input changed times	With this I/O refreshing method, the Input Units record the DC times when inputs change.
Output refreshing with specified time stamps	With this I/O refreshing method, the Output Units change outputs at specified DC times.
Free-Run refreshing	With this I/O refreshing method, the refresh cycle of the NX bus and the I/O refresh cycles of the NX Units are asynchronous.

\*1. Of the EtherCAT Coupler Units, only the NX-ECC203 supports this refreshing method.

Because the EtherCAT Coupler Unit can perform all I/O refreshing methods at the same time, NX Units with different I/O refreshing methods can be used together in the EtherCAT Slave Terminals. Refer to the manuals for the specific NX Units for details on the operation for each I/O refreshing method.

### Version Information

Time stamp refreshing is an I/O refreshing method that was added for a version upgrade. Refer to *A-11-2 Functions That Were Added or Changed for Each Unit Version* on page A-103 for the versions that support time stamp refreshing.

## 10-3-2 Setting the I/O Refreshing Methods

The I/O refreshing method between the EtherCAT Coupler Unit and each NX Unit depends on whether the DC is enabled in the EtherCAT Coupler Unit.

DC enable setting in the EtherCAT Coupler Unit	NX Units that support only Free-Run refreshing	NX Units that support only synchronous I/O refreshing	NX Units that support both Free-Run refreshing and synchronous I/O refreshing	NX Units that support Free-Run refreshing, synchronous I/O refreshing, and task period prioritized refreshing	NX Units that support only time stamp refreshing
Enabled (DC for synchronization)* <sup>1</sup>	Free-Run refreshing	Synchronous I/O refreshing	Synchronous I/O refreshing	Synchronous I/O refreshing	Time stamp refreshing
Enabled (DC with priority in cycle time)* <sup>1</sup>				Task period prioritized refreshing	
Disabled (Free-Run)* <sup>2</sup>		Not available.	Free-Run refreshing	Free-Run refreshing	Operation with time stamp refreshing is not possible.* <sup>3</sup>

\*1. The EtherCAT Slave Terminal operates in DC Mode.

\*2. The EtherCAT Slave Terminal operates in Free-Run Mode.

\*3. Refer to the manuals for the specific NX Units for details on the operation when the DC is set to Disabled (FreeRun).



### Additional Information

To enable the distributed clock for the EtherCAT Coupler Unit, set the *Enable Distributed Clock* slave parameter on the Edit Configuration Dialog Box on the Sysmac Studio. The default setting on the Sysmac Studio is *Enabled (DC for synchronization)*.

Refer to *9-2-2 Settings as an EtherCAT Slave* on page 9-7 for the setting method.

### 10-3-3 Selecting NX Units

The I/O refreshing methods that you can use depend on the model of the NX Unit. Select the NX Units according to the I/O refreshing method to use.

Refer to the manuals for the specific Units for the I/O refreshing methods that are supported by individual NX Units.

### 10-3-4 I/O Refreshing Method Operation

This section describes the operation of each I/O refreshing method.

The detailed operation of the I/O refreshing methods depends on the NX Units. Refer to the manuals for the NX Units.



#### Additional Information

Refer to *A-4 Connecting to Masters from Other Manufacturers* on page A-12 for details on the operation of I/O refreshing with connections that do not use the built-in EtherCAT port.

## Operation of Synchronous I/O Refreshing

All NX Units that support synchronous I/O refreshing in the EtherCAT Slave Terminal read their inputs at the same time at a fixed interval based on Sync0. These NX Units also refresh their outputs simultaneously but at different intervals from the intervals for the inputs.

If there is more than one Slave Terminal on the same EtherCAT network, the above operation is performed for the Slave Terminals for which I/O refreshing is performed in the same periodic task. The NX Units that use only synchronous I/O refreshing in all of the Slave Terminals for which I/O is refreshed in the same periodic task receive inputs and refresh outputs simultaneously. The periodic tasks to which you can assign the I/O refreshing of a Slave Terminal depend on the type of CPU Unit or Industrial PC to which the Slave Terminal is connected as shown below.

Type of CPU Unit or Industrial PC*1	Periodic task in which I/O is refreshed
NX-series NX701 CPU Unit	Primary periodic task or priority-5 periodic task
NX-series NX1P2 CPU Unit	Primary periodic task
NJ-series CPU Unit or NY-series Industrial PC	

\*1. If you connect the Slave Terminal to a CPU Unit or Industrial PC whose model is not included in the table, refer to *Assignment and Settings Related to Tasks* in the software user's manual for the connected CPU Unit or Industrial PC for information on the periodic tasks in which Slave Terminal I/O is refreshed.

*NX Units (No.1 to 3) in EtherCAT Slave Terminals #2 and #3* in the figure labeled *Example of Synchronous I/O Refreshing Operation* on page 10-11 provide examples of operation with synchronous I/O refreshing.

All NX Units read their inputs at the same time ((A) in the figure).

All NX Units refresh their outputs at the same time ((B) in the figure).



### Precautions for Correct Use

---

The Sysmac Studio automatically calculates Sync0, the timing of reading and updating outputs, and the maximum NX bus refresh cycle for multiple Slave Terminals. It calculates them according to factors such as the I/O refresh cycles and the data sizes of the NX Units in the Slave Terminals when the Slave Terminals are configured and set up. If you use a built-in EtherCAT port that can perform process data communications with a Slave Terminal in more than one periodic task, this is calculated for each periodic task.

If you use synchronous I/O refreshing, you must set the task period of the periodic task to a value that is longer than the NX bus refresh cycle that is automatically calculated by the Sysmac Studio. Refer to *10-3-5 Setting the Task Periods of Periodic Tasks* on page 10-18 for details.

---



### Additional Information

---

The EtherCAT Slave Terminals with enabled distributed clocks and all EtherCAT slaves that support DC synchronization execute I/O processing based on Sync0, which is shared on the EtherCAT network. Because these EtherCAT Slave Terminals and these EtherCAT slaves have different specifications and performance levels for the timing of reading inputs and updating outputs, they do not read inputs or update outputs simultaneously.

Also, even for two EtherCAT slaves that support distributed clock synchronization, the specifications and performances for the timing of reading inputs and the timing of updating outputs can be different for different slaves. This means that inputs are not always read and outputs are not always updated simultaneously.

---

## ● Example of Synchronous I/O Refreshing Operation

An example of operation for the synchronous I/O refreshing method is provided in the following figure. The following figure is an example for the primary periodic task, but the same operation is performed with the priority-5 periodic task.

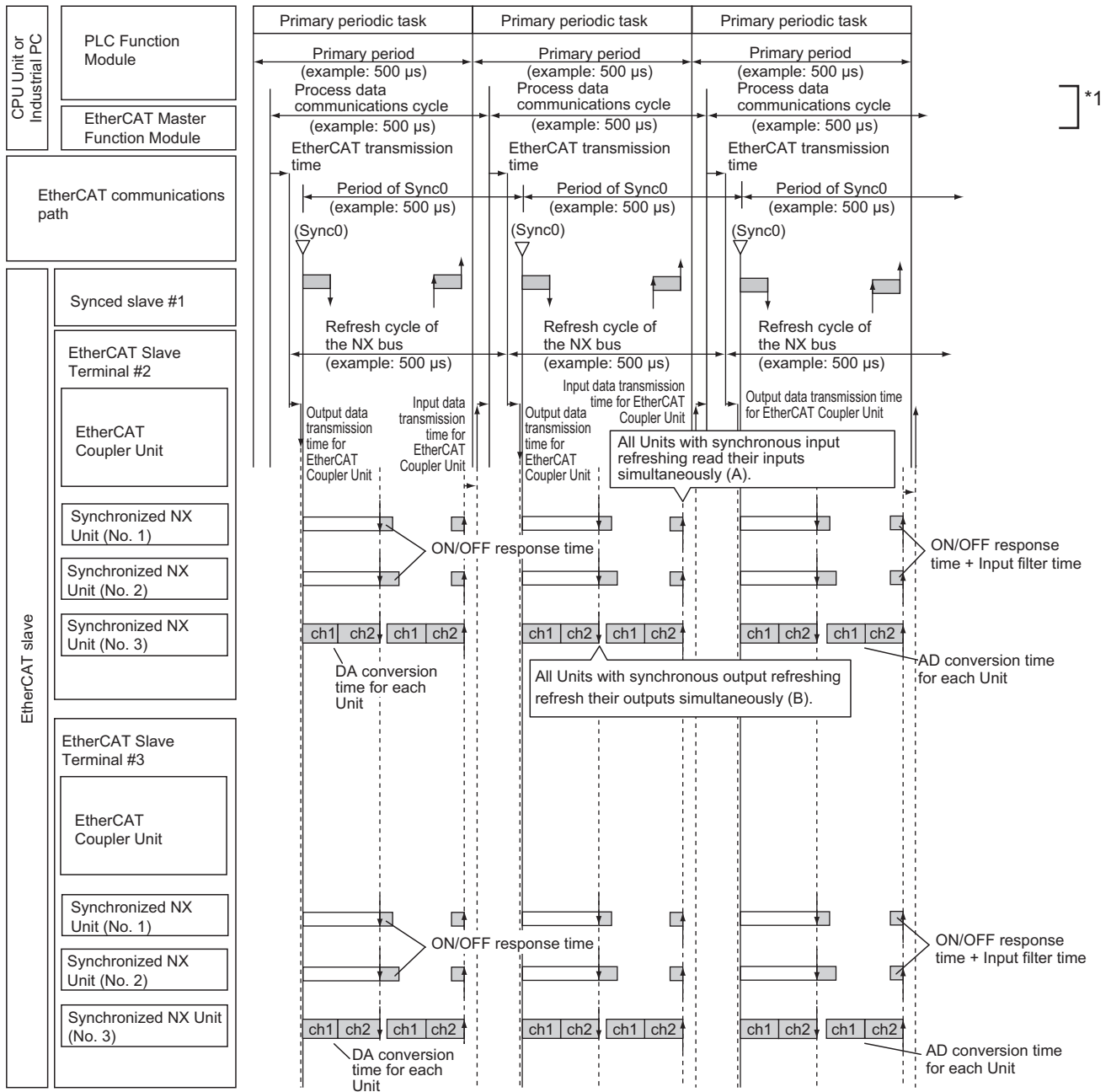

\*1. For a built-in EtherCAT port that can perform process data communications with a Slave Terminal in more than one periodic task, this is called process data communications cycle 1.

## Operation for Task Period Prioritized Refreshing

This section describes the operation of task period prioritized refreshing.

### ● Operation with Input Prioritized Refreshing

The NX Units that use input prioritized refreshing in the EtherCAT Slave Terminal give priority to execution of the input processing for each NX Unit. Output processing is executed after input processing is completed.

*Input-prioritized NX Unit (No. 1) in EtherCAT Slave Terminals #2 and #3* in the figure labeled *Example of Task Period Prioritized Refreshing Operation* on page 10-13 provide examples of operation with input prioritized refreshing.

Execution of input processing for each NX Unit is given priority. Output processing is performed after input processing is completed ((A) in the figure).

Input processing is executed until the I/O refreshing of the EtherCAT Coupler Unit ((B) in the figure).

### ● Operation with Output Prioritized Refreshing

The NX Units that use output prioritized refreshing in the EtherCAT Slave Terminal give priority to execution of the output processing for each NX Unit. Input processing is executed after output processing is completed.

The input data from input processing is read by the EtherCAT Coupler Unit in the next period after the period in which the output processing is performed.

*Output-prioritized NX Unit (No. 2) in EtherCAT Slave Terminals #2 and #3* in the figure labeled *Example of Task Period Prioritized Refreshing Operation* on page 10-13 provide examples of operation with output prioritized refreshing.

The EtherCAT Coupler Unit gets the input data in the next period after the period in which each NX Unit performs output processing ((C) in the figure).

Execution of output processing is given priority starting on Sync0. Input processing is executed after output processing is completed ((D) in the figure).



### Precautions for Correct Use

The Sysmac Studio automatically calculates Sync0, the timing of reading inputs and updating outputs, and the maximum NX bus refresh cycle for multiple Slave Terminals. It calculates them according to factors such as the I/O refresh cycles and the data sizes of the NX Units in the Slave Terminals when the Slave Terminals are configured and set up. If you use a built-in EtherCAT port that can perform process data communications with a Slave Terminal in more than one periodic task, this is calculated for each periodic task.

If you use task period prioritized refreshing, you must set the task period of the periodic task to a value that is longer than the NX bus refresh cycle that is automatically calculated by the Sysmac Studio. Refer to *10-3-5 Setting the Task Periods of Periodic Tasks* on page 10-18 for details.

### ● Example of Task Period Prioritized Refreshing Operation

An example of operation for the task period prioritized refreshing method is provided in the following figure. The following figure is an example for the primary periodic task, but the same operation is performed with the priority-5 periodic task.

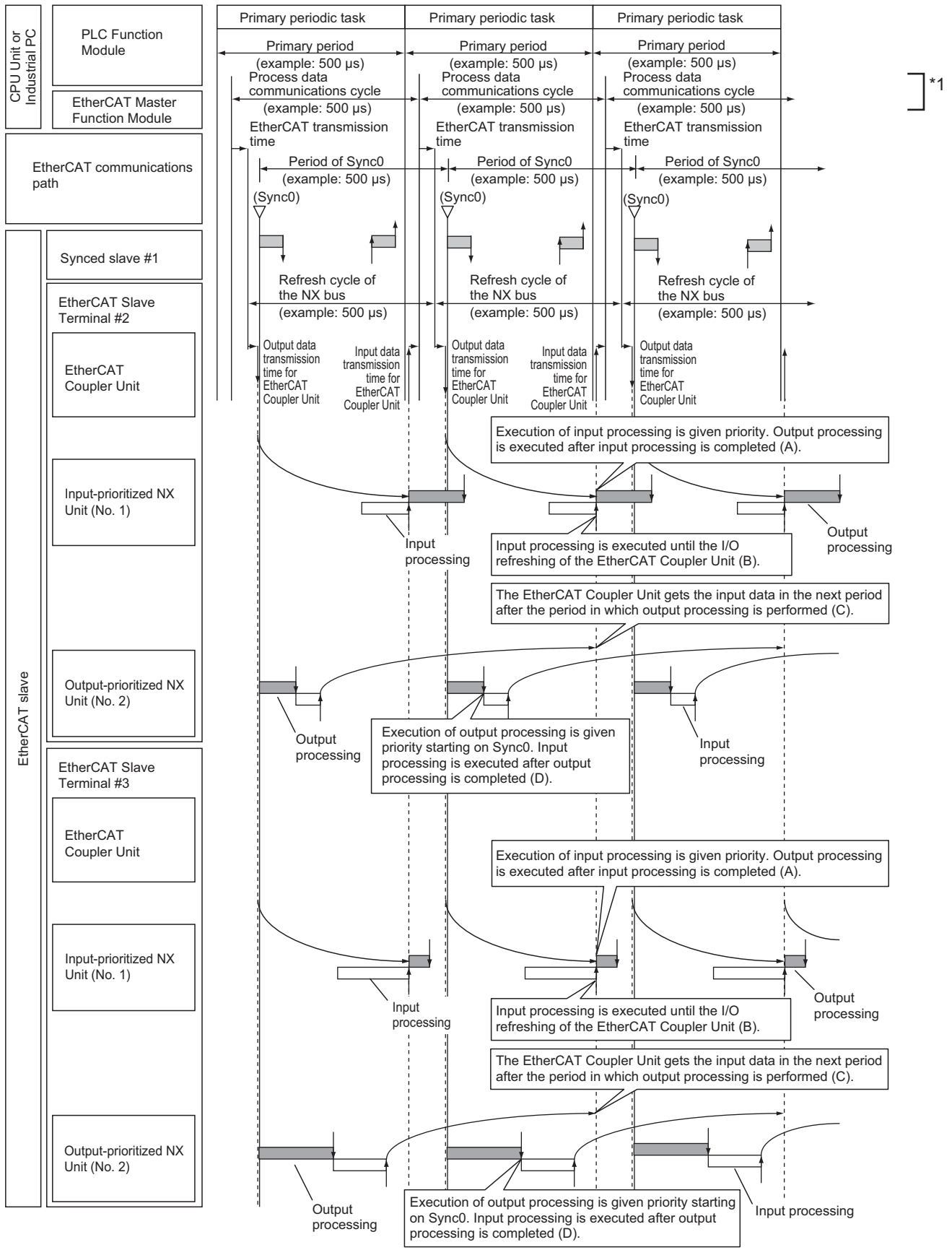

\*1. For a built-in EtherCAT port that can perform process data communications with a Slave Terminal in more than one periodic task, this is called process data communications cycle 1.

## Operation of Time Stamp Refreshing

This section describes the operation of time stamp refreshing.

### ● Operation of Input Refreshing with Input Changed Times

All NX Units that use input refreshing with input changed times in the EtherCAT Slave Terminal record the DC times when inputs change (called input changed times). These times are read when the inputs change at a set fixed interval based on Sync0. The most recent values are always read as the input values.



#### Additional Information

The timing when the input changed times are read is the same as that for reading the inputs for NX Units that use synchronous input refreshing.

If there is more than one Slave Terminal on the same EtherCAT network, the above operation is performed for the Slave Terminals for which I/O refreshing is performed in the same periodic task. The NX Units that use only input refreshing with input changed time in all of the Slave Terminals for which I/O is refreshed in the same periodic task read the input changed times simultaneously. The periodic tasks to which you can assign the I/O refreshing of a Slave Terminal depend on the type of CPU Unit or Industrial PC to which the Slave Terminal is connected as shown below.

Type of CPU Unit or Industrial PC <sup>*1</sup>	Periodic task in which I/O is refreshed
NX-series NX701 CPU Unit	Primary periodic task or priority-5 periodic task
NX-series NX1P2 CPU Unit	Primary periodic task
NJ-series CPU Unit or NY-series Industrial PC	

\*1. If you connect the Slave Terminal to a CPU Unit or Industrial PC whose model is not included in the table, refer to *Assignment and Settings Related to Tasks* in the software user's manual for the connected CPU Unit or Industrial PC for information on the periodic tasks in which Slave Terminal I/O is refreshed.

*NX Unit with input refreshing with input changed times (No. 1) in EtherCAT Slave Terminals #2 and #3* in the figure labeled *Operation Example for Time Stamp Refreshing* on page 10-16 provide an example of operation with input refreshing with input changed times.

All NX Units read their input changed times at the same time ((A) in the figure).

The DC times when the inputs changed are recorded for each NX Unit ((B) in the figure).

### ● Operation of Output Refreshing with Specified Time Stamps

NX Units that support output refreshing with specified time stamps in the EtherCAT Slave Terminal change the outputs at the specified DC times for each NX Unit.

*NX Unit with output refreshing with specified time stamps (No. 2) in EtherCAT Slave Terminals #2 and #3* in the figure labeled *Operation Example for Time Stamp Refreshing* on page 10-16 provide an example of operation with output refreshing with specified time stamps.

The outputs are changed at the specified DC times for each NX Unit ((C) in the figure).



**Precautions for Correct Use**

The Sysmac Studio automatically calculates Sync0, the timing of reading inputs and updating outputs, and the maximum NX bus refresh cycle for multiple Slave Terminals. It calculates them according to factors such as the I/O refresh cycles and the data sizes of the NX Units in the Slave Terminals when the Slave Terminals are configured and set up. If you use a built-in EtherCAT port that can perform process data communications with a Slave Terminal in more than one periodic task, this is calculated for each periodic task.

If you use time stamp refreshing, you must set the task period of the periodic task to a value that is longer than the NX bus refresh cycle that is automatically calculated by the Sysmac Studio. Refer to 10-3-5 *Setting the Task Periods of Periodic Tasks* on page 10-18 for details.

**● Operation Example for Time Stamp Refreshing**

An example of operation for the time stamp refreshing method is provided in the following figure. The following figure is an example for the primary periodic task, but the same operation is performed with the priority-5 periodic task.

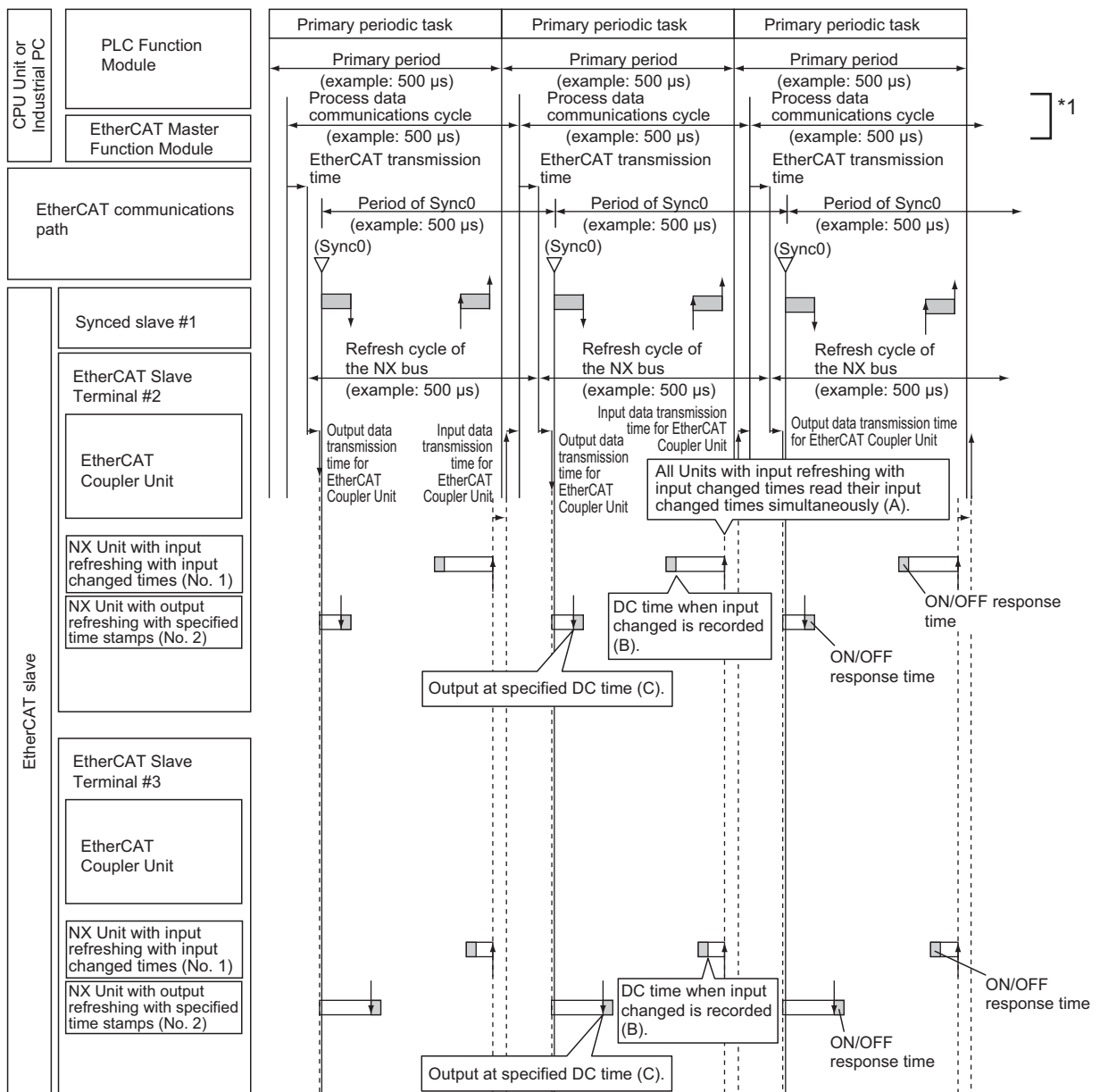

- \*1. For a built-in EtherCAT port that can perform process data communications with a Slave Terminal in more than one periodic task, this is called process data communications cycle 1.

## Operation of Free-Run Refreshing

With Free-Run refreshing, the refresh cycle of the NX bus and the I/O refresh cycle of the NX Units operate asynchronously.

*Free-run NX Unit (No. 1) in EtherCAT Slave Terminal #2* in the figure labeled *Example of Free-Run Refreshing Operation* on page 10-17 provides an example of operation with Free-Run refreshing. The NX Units perform I/O processing based on their own unique timings ((A) and (B) in the figure), independent of Sync0.

### ● Example of Free-Run Refreshing Operation

An example of operation for Free-Run refreshing method is provided in the following figure. This example shows the operation of EtherCAT Slave Terminals in DC Mode. The following figure is an example for the primary periodic task, but the same operation is performed with the priority-5 periodic task.

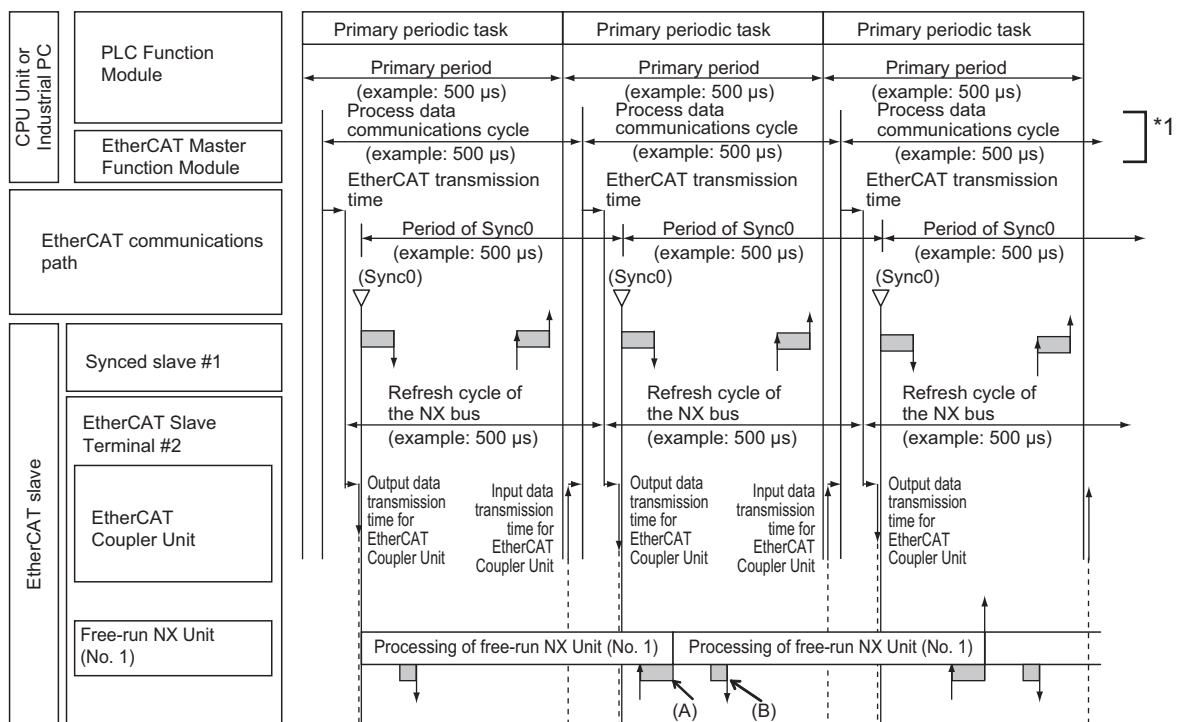

- \*1. For a built-in EtherCAT port that can perform process data communications with a Slave Terminal in more than one periodic task, this is called process data communications cycle 1.

Operation is as follows for EtherCAT Slave Terminals that operate in Free-Run Mode:

- The NX bus refresh cycle is not synchronized with the task periods of the periodic tasks or process data communications cycle. The NX bus operates on its own cycle.
- The refresh cycle of the NX bus and the I/O refresh cycles of the NX Units are asynchronous.

### 10-3-5 Setting the Task Periods of Periodic Tasks

This section describes the settings of the task periods of the primary periodic task and priority-5 periodic task. Process data communications can be performed from these tasks. This is explained for each series of CPU Unit or Industrial PC that connects to EtherCAT Slave Terminals.

#### Connecting to the Built-in EtherCAT Port on an NX-series NX701 CPU Unit

The task periods must be set within the following restrictions.

- Relation of the task periods between different periodic tasks
- Communications cycle for EtherCAT Slave Terminals in DC Mode
- Communications cycle for EtherCAT Slave Terminals in Free-Run Mode
- Refresh cycle of the NX bus

##### ● Relation of the Task Periods between Different Periodic Tasks

Set the task period of the priority-5 periodic task as an integer multiple of the primary period.

For details on setting the task periods for an NX-series CPU Unit, refer to *Specifications of Tasks* for the NX-series CPU Unit in the *NJ/NX-series CPU Unit Software User's Manual (Cat. No. W501)*.

##### ● Communications Cycle for EtherCAT Slave Terminals in DC Mode

To operate an EtherCAT Slave Terminal in DC Mode, set a task period within the specified range for the DC Mode communications cycle supported by the EtherCAT Slave Terminal.

Refer to *3-1-2 EtherCAT Coupler Unit Specifications* on page 3-2 for the DC Mode communications cycles that are supported by the EtherCAT Slave Terminals. There are restrictions in the communications cycles that you can set for some of the NX Units. If you use any of those NX Units, set a task period for a communications cycle that will satisfy the specifications for the refresh cycles that can be executed by the NX Unit. Refer to the appendix of the *NX-series Data Reference Manual (Cat. No. W525)* to see if there are restrictions on any specific NX Units. For information on the communications cycles that you can set, refer to the user's manuals for the NX Units.



##### Precautions for Correct Use

There are restrictions in the communications cycles in DC Mode that you can set for some of the NX Units. For example, there are some models of NX Units that cannot refresh I/O at a task period of 125  $\mu$ s, and there are other models of NX Units that cannot refresh I/O at a task period of 125  $\mu$ s unless you use task period prioritized refreshing. If you use any of those NX Units, set a task period for a communications cycle that will satisfy the specifications for the refresh cycles that can be executed by the NX Unit.

##### ● Communications Cycle for EtherCAT Slave Terminals in Free-Run Mode

To operate an EtherCAT Slave Terminal in Free-Run Mode, set a task period within the specified range for the Free-Run Mode communications cycle supported by the EtherCAT Slave Terminal.

Refer to *3-1-2 EtherCAT Coupler Unit Specifications* on page 3-2 for the Free-Run Mode communications cycles that are supported by the EtherCAT Slave Terminals. There are restrictions in the communications cycles that you can set for some of the NX Units. If you use any of those NX Units, set a task period for a communications cycle that will satisfy the specifications for the refresh cycles that can be executed by the NX Unit. Refer to the appendix of the *NX-series Data Reference*

*Manual (Cat. No. W525)* to see if there are restrictions on any specific NX Units. For information on the communications cycles that you can set, refer to the user's manuals for the NX Units.

## ● Refresh Cycle of the NX Bus

### a. Operating the EtherCAT Slave Terminal in DC Mode

You must set the task periods of the primary task and priority-5 periodic task to values that are longer than the NX bus refresh cycle that is automatically calculated by the Sysmac Studio for each periodic task.

The Sysmac Studio provides a task period warning if the task period of the primary task or priority-5 periodic task is shorter than the NX bus refresh cycle. A warning is displayed to the left of **EtherCAT** under **Configurations and Setup** in the Multiview Explorer and also to the right of the master on the EtherCAT Configuration Edit Tab Page. If you place the cursor on the warning mark, the task period that is required for the primary task or priority-5 periodic task is displayed. Set the task period of the primary periodic task or priority-5 periodic task accordingly.

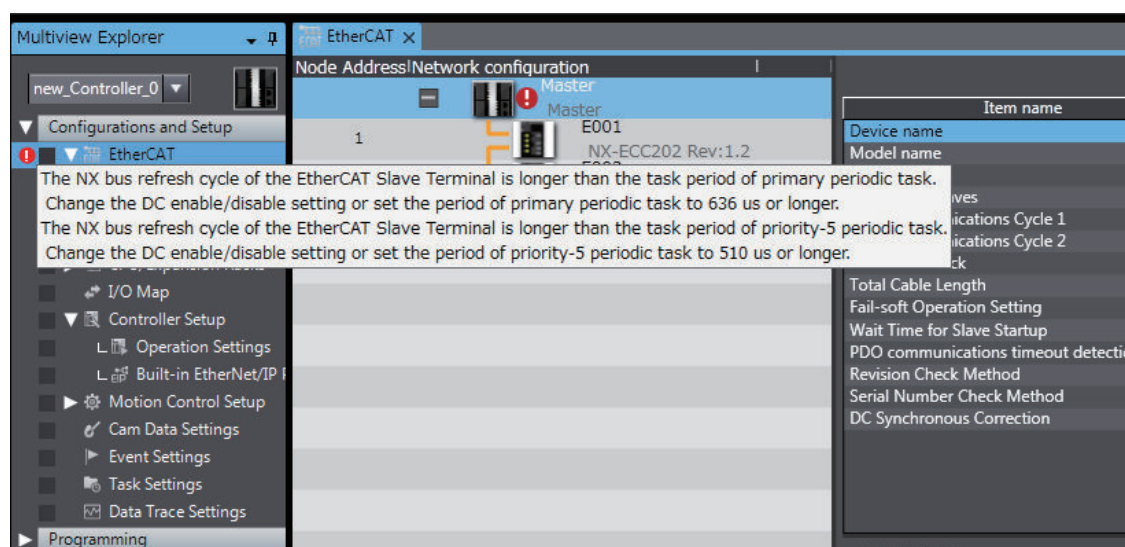

With the task period of the primary task or priority-5 periodic task in **Configurations and Setup - Task Settings**, select the task periods from the lists for the **Period/Execution Conditions** for both the primary task and priority-5 periodic task.

### b. Operating the EtherCAT Slave Terminal in Free-Run Mode

Set the task periods of the primary task and priority-5 periodic task according to *Relation of the Task Periods between Different Periodic Tasks* on page 10-18 and *Communications Cycle for EtherCAT Slave Terminals in Free-Run Mode* on page 10-18.

The NX bus refresh cycle for each process data communications cycle is not synchronized with the following cycles. The NX bus operates on its own cycle.

- Primary period and process data communications cycle 1
- Task period of priority-5 periodic task and process data communications cycle 2

Therefore, the Sysmac Studio will not provide a task period warning if the task period of the primary task or priority-5 periodic task is shorter than the NX bus refresh cycle for either of the process data communications.



### Precautions for Correct Use

#### Restrictions in Process Data Communications for Multiple Communications Cycles

With a built-in EtherCAT port that can perform process data communications in more than one periodic task on the same EtherCAT network, the following restrictions apply because there is physically only one EtherCAT network and because the primary periodic task is given priority.

- Even if the same task period is set for the primary task and priority-5 periodic task, the PDO data size that can be processed for the EtherCAT slave by the built-in EtherCAT port in the priority-5 periodic task may be less than the data size processed in the primary periodic task. For details on the restrictions on process data communications in multiple communications cycles, refer to *Restrictions for Multiple Communications Cycles* in the *NJ/NX-series CPU Unit Built-in EtherCAT Port User's Manual (Cat. No. W505)*.

## Connecting to the Built-in EtherCAT Port on Other NX-series CPU Units

When connected to a built-in EtherCAT port of a CPU Unit that is not an NX-series NX701 CPU Unit, the task periods must be set within the following restrictions.

- Communications cycle for EtherCAT Slave Terminals in DC Mode
- Refresh cycle of the NX bus

### ● Communications Cycle for EtherCAT Slave Terminals in DC Mode

To operate an EtherCAT Slave Terminal in DC Mode, set a task period within the specified range for the DC Mode communications cycle supported by the EtherCAT Slave Terminal. For example, 4,000  $\mu\text{s}$  is the maximum communications cycle for DC Mode with the NX-ECC201 or NX-ECC202. Therefore, when you set the task period to a value greater than 4,000  $\mu\text{s}$  for the built-in EtherCAT port on a CPU Unit, you cannot use the NX-ECC201/ECC202. Refer to *3-1-2 EtherCAT Coupler Unit Specifications* on page 3-2 for the DC Mode communications cycles that are supported by the EtherCAT Slave Terminals.

### ● Refresh Cycle of the NX Bus

The restrictions are the same as when connecting to the built-in EtherCAT port on an NJ-series CPU Unit, which are described below. Refer to *Connecting to the Built-in EtherCAT Port on an NJ-series CPU Unit* on page 10-20 for details.

## Connecting to the Built-in EtherCAT Port on an NJ-series CPU Unit

The task periods must be set within the following restrictions.

- Refresh cycle of the NX bus

Details are given below.

### ● Operating the EtherCAT Slave Terminal in DC Mode

Set the primary period so that it is longer than the NX bus refresh cycle that is automatically calculated by the Sysmac Studio.

The Sysmac Studio provides a task period warning if the primary period is smaller than the NX bus refresh cycle. A warning is displayed to the left of **EtherCAT** under **Configurations and Setup** in the Multiview Explorer and also to the right of the master on the EtherCAT Configuration Edit Tab

Page. If you place the cursor on the warning mark, the required primary period is displayed. Set the primary period accordingly.

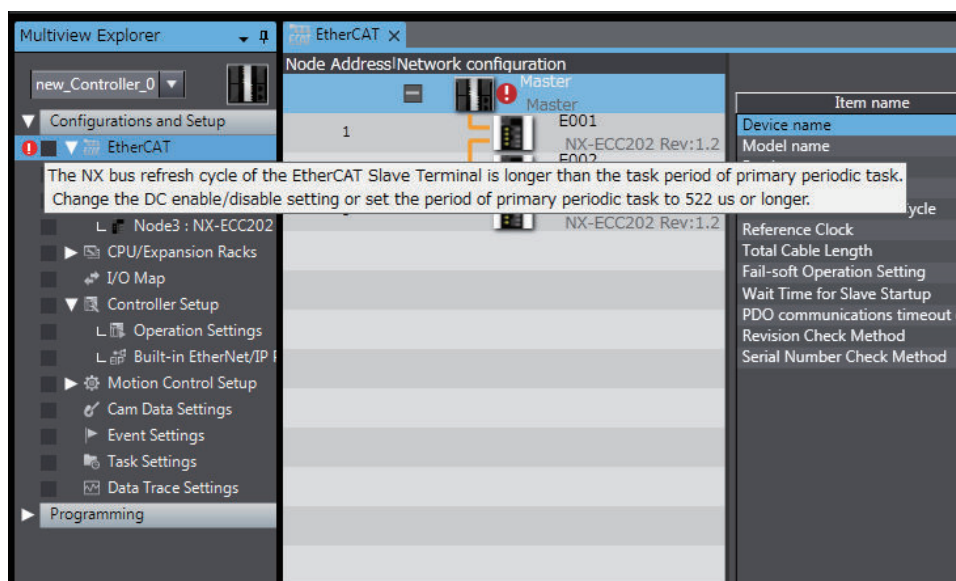

With the primary periodic task in **Configurations and Setup - Task Settings**, select the task period from the list for the **Period/Execution Conditions**.

### ● Operating the EtherCAT Slave Terminal in Free-Run Mode

Set the primary period according to *Communications Cycle for EtherCAT Slave Terminals in Free-Run Mode* on page 10-18. The NX bus refresh cycle is not synchronized with the primary period or process data communications cycle. The NX bus operates on its own cycle. Therefore, the Sysmac Studio does not provide a task period warning if the primary period is smaller than the NX bus refresh cycle.

## Connecting to a Built-in EtherCAT Port on an NY-series Industrial PC

The task periods must be set within the following restrictions.

- Communications cycle for EtherCAT Slave Terminals in DC Mode
- Refresh cycle of the NX bus

### ● Communications Cycle for EtherCAT Slave Terminals in DC Mode

To operate an EtherCAT Slave Terminal in DC Mode, set a task period within the specified range for the DC Mode communications cycle supported by the EtherCAT Slave Terminal. For example, the communications cycle for DC Mode for the NX-ECC201/ECC202 is 4,000  $\mu$ s max. Therefore, if you set the task period for an NY-series Industrial PC to a value greater than 4,000  $\mu$ s, you cannot use the NX-ECC201/ECC202. Refer to *3-1-2 EtherCAT Coupler Unit Specifications* on page 3-2 for the DC Mode communications cycles that are supported by the EtherCAT Slave Terminals.

### ● Refresh Cycle of the NX Bus

The same restrictions apply when connecting to the built-in EtherCAT port on an NJ-series CPU Unit. Refer to *Connecting to the Built-in EtherCAT Port on an NJ-series CPU Unit* on page 10-20 for details.

### 10-3-6 Task Allocations

This section describes the specifications to assign EtherCAT Slave Terminals to tasks in an NJ/NX-series CPU Unit or NY-series Industrial PC. This is explained for each series of CPU Unit that connects to EtherCAT Slave Terminals. If you connect the Slave Terminal to a CPU Unit or Industrial PC whose model is not given here, refer to *Assignment and Settings Related to Tasks* in the software user's manual for the connected CPU Unit or Industrial PC for information on the task assignment specifications.

#### Connecting to the Built-in EtherCAT Port on an NX-series NX701 CPU Unit

##### ● Number of Tasks to Assign

You can assign only one task to each EtherCAT Slave Terminal.  
You cannot assign a task to each NX Unit.

##### ● Assignable Tasks

The tasks that you can assign depends on whether the EtherCAT Slave Terminal to which you are assigning the task contains an NX Unit to which an axis is assigned. The assignable tasks are given in the following table.

NX Unit with axis assignment	Assignable tasks
Present	<ul style="list-style-type: none"> <li>• Primary periodic task</li> <li>• Priority-5 periodic task</li> </ul>
Not present	<ul style="list-style-type: none"> <li>• Primary periodic task</li> <li>• Priority-5 periodic task</li> <li>• Priority-16 periodic task</li> </ul>

If Safety Control Units are mounted to more than one EtherCAT Slave Terminal, there are restrictions in the combinations of tasks that you can assign. You cannot assign both the priority-5 periodic task and a periodic task other than the priority-5 periodic task.

Refer to the *NJ/NX-series CPU Unit Software User's Manual (Cat. No. W501)* for information on designing tasks for an NX-series CPU Unit.

#### Connecting to the Built-in EtherCAT Port on an NX-series NX1P2 CPU Unit

##### ● Number of Tasks to Assign

You can assign only one task to each EtherCAT Slave Terminal.  
You cannot assign a task to each NX Unit.

##### ● Assignable Tasks

The tasks that you can assign depend on whether the EtherCAT Slave Terminal to which you are assigning the task contains an NX Unit to which an axis is assigned. The assignable tasks are given in the following table.

NX Unit with axis assignment	Assignable tasks
Present	Primary periodic task
Not present	

Refer to the *NJ/NX-series CPU Unit Software User's Manual (Cat. No. W501)* for information on designing tasks for an NX-series CPU Unit.

## Connecting to the Built-in EtherCAT Port on an NJ-series CPU Unit

### ● Number of Tasks to Assign

You can assign only one task to each EtherCAT Slave Terminal.

You cannot assign a task to each NX Unit.

### ● Assignable Tasks

The tasks that you can assign depends on whether the EtherCAT Slave Terminal to which you are assigning the task contains an NX Unit to which an axis is assigned. The assignable tasks are given in the following table.

NX Unit with axis assignment	Assignable tasks
Present	Primary periodic task
Not present	Primary periodic task or priority-16 periodic task

Refer to the *NJ/NX-series CPU Unit Software User's Manual (Cat. No. W501)* for information on designing tasks for an NJ-series CPU Unit.

## Connecting to the Built-in EtherCAT Port on an NY-series Industrial PC

The same specifications apply when connecting to the built-in EtherCAT port on an NJ-series CPU Unit. Refer to *Connecting to the Built-in EtherCAT Port on an NJ-series CPU Unit* on page 10-23 for details. For information on task design for an NY-series Industrial PC, refer to the *NY-series IPC Machine Controller Industrial Panel PC / Industrial Box PC Software User's Manual (Cat. No. W558)*.



# 11

## EtherCAT Coupler Unit Functions

This section describes the functions of the EtherCAT Coupler Unit when it is used in an EtherCAT Slave Terminal.

<b>11-1</b>	<b>Functions .....</b>	<b>11-3</b>
<b>11-2</b>	<b>NX Unit Mounting Settings .....</b>	<b>11-6</b>
11-2-1	Introduction.....	11-6
11-2-2	Applications .....	11-7
11-2-3	Operating Specifications for NX Units That Are Set as Unmounted Units .....	11-8
11-2-4	Setting NX Units as Unmounted Units .....	11-9
<b>11-3</b>	<b>Sysmac Device Functionality Unique to EtherCAT Slaves .....</b>	<b>11-11</b>
<b>11-4</b>	<b>Security .....</b>	<b>11-13</b>
11-4-1	Supported Security Functions .....	11-13
11-4-2	Specifications of Verification of Operation Authority for the EtherCAT Slave Terminal.....	11-13
<b>11-5</b>	<b>Event Logs.....</b>	<b>11-15</b>
11-5-1	Introduction.....	11-15
11-5-2	Detailed Information on Event Logs .....	11-16
11-5-3	Reading Event Logs .....	11-19
11-5-4	Clearing Event Logs .....	11-20
11-5-5	Exporting the Event Log .....	11-22
<b>11-6</b>	<b>Clearing All Memory .....</b>	<b>11-23</b>
11-6-1	Introduction.....	11-23
11-6-2	Details on Clearing All Memory .....	11-23
11-6-3	Procedure for Clearing All Memory .....	11-24
<b>11-7</b>	<b>Restarting .....</b>	<b>11-26</b>
11-7-1	Introduction.....	11-26
11-7-2	Details on Restarting .....	11-26
11-7-3	Procedure for Restarting .....	11-27
<b>11-8</b>	<b>Changing Event Levels.....</b>	<b>11-29</b>
11-8-1	Introduction.....	11-29
11-8-2	Details on Changing Event Levels .....	11-29
11-8-3	Procedure to Change an Event Level .....	11-29
<b>11-9</b>	<b>Resetting Errors .....</b>	<b>11-31</b>
11-9-1	Introduction.....	11-31
11-9-2	Details on Resetting Errors .....	11-31
11-9-3	Procedure to Reset Errors.....	11-32
<b>11-10</b>	<b>I/O Checking.....</b>	<b>11-35</b>

11-10-1	Overview .....	11-35
11-10-2	Details on I/O Checking.....	11-35
11-10-3	Procedure Required before I/O Checking .....	11-37
11-10-4	I/O Checking Operating Procedure .....	11-39
<b>11-11</b>	<b>Fail-soft Operation.....</b>	<b>11-41</b>
11-11-1	Overview .....	11-41
11-11-2	Application.....	11-42
11-11-3	Details on Fail-soft Operation .....	11-42
<b>11-12</b>	<b>Prohibiting USB Connections .....</b>	<b>11-45</b>
11-12-1	Overview .....	11-45
11-12-2	Details on Prohibiting USB Connections .....	11-45
<b>11-13</b>	<b>Monitoring Total Power-ON Time.....</b>	<b>11-47</b>
11-13-1	Overview .....	11-47
11-13-2	Details on Monitoring Total Power-ON Times.....	11-47
11-13-3	Checking Total Power-ON Times .....	11-47

# 11-1 Functions

The functions of EtherCAT Coupler Units when they are used in EtherCAT Slave Terminals are listed below. Refer to *A-10 Functional Restrictions by Model* on page A-101 for the functions that are supported by each model of EtherCAT Coupler Unit.

Function	Overview	Reference
Setting Slave Terminals	This function is used to read and set the Slave Terminal parameters from the Sysmac Studio. You can make settings offline, or go online and read and set the Unit configuration of the actual Slave Terminals.	<i>Section 9 Setting Up Slave Terminals</i> on page 9-1
Cyclic I/O Refreshing	The EtherCAT Coupler Unit exchanges I/O data at a fixed interval with the mounted NX Units. There are the following methods to exchange I/O. <ul style="list-style-type: none"> <li>• Free-Run refreshing</li> <li>• Synchronous I/O refreshing</li> <li>• Task period prioritized refreshing<sup>*1</sup></li> <li>• Time stamp refreshing</li> </ul> Even if the EtherCAT Coupler Unit is connected to NX Units that use different refreshing methods, it exchanges I/O data with the NX Units according to the method set for each NX Unit.	<i>Section 10 I/O Refreshing</i> on page 10-1
Free-Run Refreshing	With this I/O refreshing method, the refresh cycle of the NX bus and the I/O refresh cycles of the NX Units are asynchronous.	
Synchronous I/O Refreshing	With this I/O refreshing method, the timing to read inputs or to refresh outputs is synchronized on a fixed interval between more than one NX Unit on more than one Slave Terminal. Use the following methods. <ul style="list-style-type: none"> <li>• Synchronous input refreshing</li> <li>• Synchronous output refreshing</li> </ul>	
Task Period Prioritized Refreshing <sup>*1</sup>	With this I/O refreshing method, shortening the task period is given priority over synchronizing the I/O timing with other NX Units. With this I/O refreshing method, the timing of I/O is not consistent with the timing of I/O for NX Units that use synchronous I/O refreshing. Use the following methods. <ul style="list-style-type: none"> <li>• Input prioritized refreshing</li> <li>• Output prioritized refreshing</li> </ul>	
Time Stamp Refreshing <sup>*2</sup>	With this I/O refreshing method, the NX Units record the DC times when inputs change or perform outputs at specified DC times. These times are asynchronous to the NX bus refresh cycles. Use the following methods. <ul style="list-style-type: none"> <li>• Input refreshing with input changed times</li> <li>• Output refreshing with specified time stamps</li> </ul>	

Function	Overview	Reference
NX Unit Mounting Settings	This function is used to register NX Units that are not connected to the actual configuration but will be added at a later time in the Unit configuration information as unmounted Units. If you use this function, you do not have to modify the user program after the NX Units are added.	11-2 <i>NX Unit Mounting Settings</i> on page 11-6
Systemac Device Functionality Unique to EtherCAT Slaves	These are the unique functions of an EtherCAT slave as a Systemac device.	11-3 <i>Systemac Device Functionality Unique to EtherCAT Slaves</i> on page 11-11
Troubleshooting with Error Notification through Systemac Error Status	This function allows the EtherCAT Coupler Unit to use the Systemac error status, which is assignable to I/O data, to notify the EtherCAT master when an error occurs. This notification acts as a trigger that allows you to use the troubleshooting functions on the Systemac Studio to view and correct errors that occur in the EtherCAT Slave Terminal.	
Saving Node Address Settings	This function sets the node address on the Systemac Studio.	
Verifying the EtherCAT Network Configuration Using Serial Numbers	This function verifies the EtherCAT network configuration based on serial numbers.	
SII Data Checking	The EtherCAT Coupler Unit checks the information in the SII (Slave Information Interface).	
Security	These functions of the NJ/NX-series CPU Unit or NY-series Industrial PC are designed to protect assets and prevent incorrect operation.	11-4 <i>Security</i> on page 11-13, Software user's manual for the connected CPU Unit or Industrial PC
Operation Authority Verification	You can set operation authorities to restrict the operations that can be performed when the Systemac Studio is used to access the EtherCAT Slave Terminal through a connection to the CPU Unit or Industrial PC.	
Event Logs	This function records events, such as errors and status changes, that occur in the EtherCAT Slave Terminal.	11-5 <i>Event Logs</i> on page 11-15
Clear All Memory	This function initializes the entire EtherCAT Slave Terminal or specified Units from the Systemac Studio.	11-6 <i>Clearing All Memory</i> on page 11-23
Restarting <sup>*2</sup>	This function allows you to apply changes to settings with the Systemac Studio or through special instructions, without cycling the Unit power supply.	11-7 <i>Restarting</i> on page 11-26
Changing Event Levels	This function allows you to change the level of errors that occur in the EtherCAT Slave Terminal.	11-8 <i>Changing Event Levels</i> on page 11-29
Resetting Errors	This function allows you to use the Systemac Studio to reset errors that occur in the EtherCAT Slave Terminal.	11-9 <i>Resetting Errors</i> on page 11-31
I/O Checking <sup>*2</sup>	This function allows you to check the wiring between NX Units and I/O devices from the Systemac Studio connected to the peripheral USB port on the EtherCAT Coupler Unit. You can monitor inputs to NX Units and change the output values from NX Units.	11-10 <i>I/O Checking</i> on page 11-35
Fail-soft Operation <sup>*2</sup>	This function allows the EtherCAT Coupler Unit to start or continue I/O refreshing only with the NX Units that can operate normally when an error occurs for the EtherCAT Slave Terminal.	11-11 <i>Fail-soft Operation</i> on page 11-41

Function	Overview	Reference
Prohibiting USB Connection* <sup>2</sup>	This function allows you to prohibit a Sysmac Studio online connection through the peripheral USB port on the EtherCAT Coupler Unit.	<i>11-12 Prohibiting USB Connections</i> on page 11-45
Monitoring Total Power-ON Time* <sup>2</sup>	Each of the EtherCAT Coupler Units and NX Units records the total time that the Unit power supply is ON to it. You can display these times on the Sysmac Studio.	<i>11-13 Monitoring Total Power-ON Time</i> on page 11-47

\*1. This method is supported only by the NX-ECC203.

\*2. These functions were added for version upgrades. Refer to *A-11-2 Functions That Were Added or Changed for Each Unit Version* on page A-103 for version upgrade information.

## 11-2 NX Unit Mounting Settings

This section describes the NX Unit mounting settings.



### Precautions for Correct Use

NX Unit mounting settings can be used when the NX Units are connected with the following OMRON master products.

- NJ/NX-series CPU Units
- NY-series Industrial PCs (NX5□□-1□00 and NY5□□-5□00)

This function cannot be used when the NX Units are connected to other manufacturer's master products or other OMRON master products.

### 11-2-1 Introduction

This function is used to register NX Units that are not connected to the actual configuration but will be added at a later time in the Unit configuration information as unmounted Units.

Using this feature offers the following benefits:

- If an unmounted Unit is registered in the Unit configuration information, it will not result in an error even if it is not actually mounted.  
This allows for the project to be downloaded to the controller, and you can confirm operation of the mounted units.
- You do not have to modify the user program after the NX Units are added.
  - a) I/O memory area is reserved for these unmounted NX Units in the same way that it is reserved for mounted NX Units.
  - b) Unmounted NX Units are also assigned NX Unit numbers. This prevents the NX Unit numbers of other NX Units in the same Slave Terminal from changing when you change the setting of an NX Unit from unmounted to mounted.

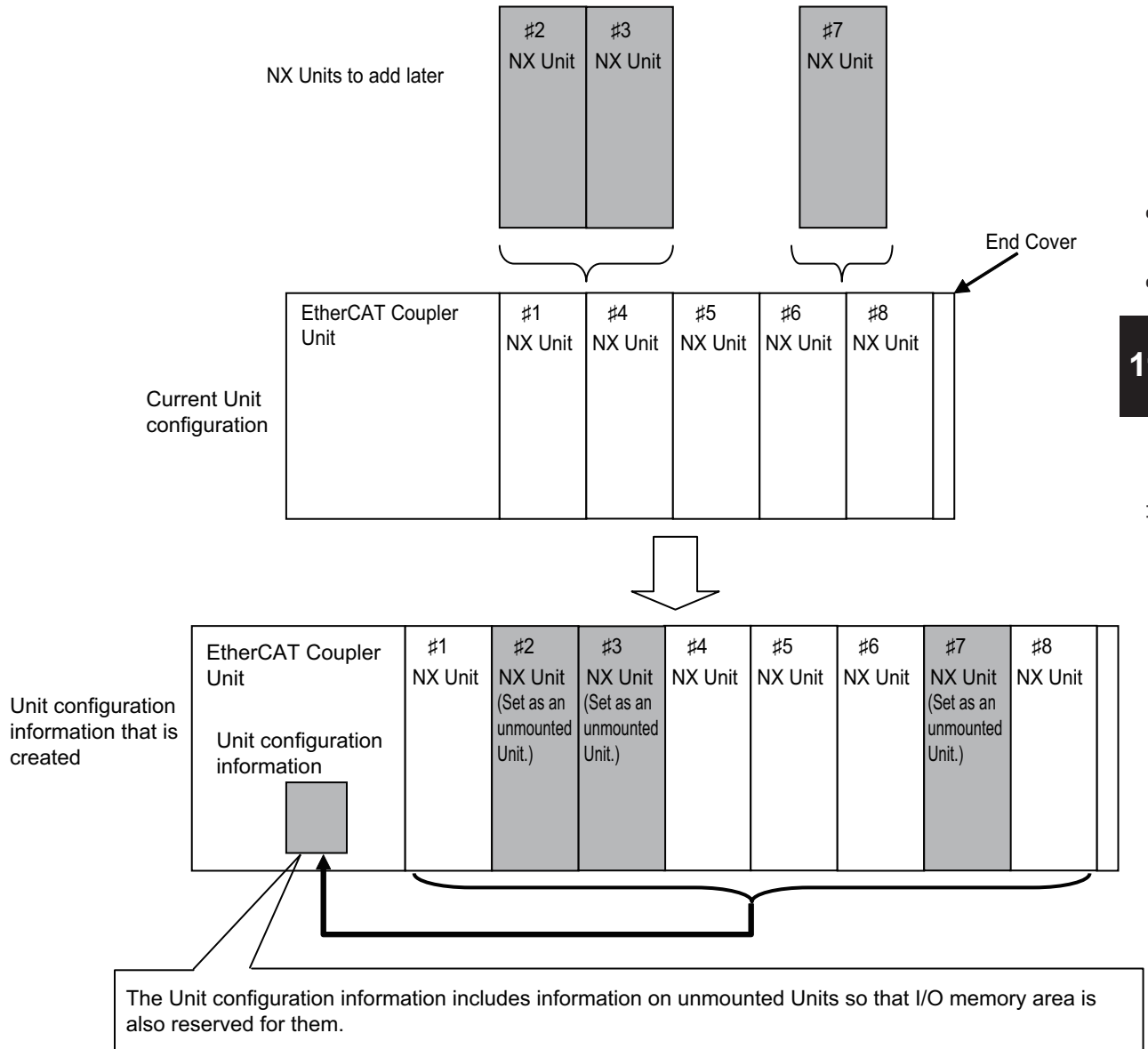

### 11-2-2 Applications

For example, if you use this function in the following cases, you do not have to modify the use program and can confirm that the mounted NX Units are operating correctly.

- When you plan to add Units in the future
- When a specific NX Unit is temporarily unavailable, such as when commissioning the system

### 11-2-3 Operating Specifications for NX Units That Are Set as Unmounted Units

The operating specifications for NX Units that are set as unmounted Units are given in the following table.

Item	Operation
Bandwidth reservation for I/O refresh data with the EtherCAT master	Bandwidth is reserved.
I/O refreshing with the EtherCAT master	The I/O is not refreshed.
Detection of events	Events are not detected.
Assignment of NX Unit numbers to NX Units	Unit numbers are not assigned because the Units do not exist.
Message communications	Not possible because the Units do not exist.
Transfers for the synchronization function of the Sysmac Studio	Not applicable.
Transfer of the Unit operation settings	Not applicable.
Sysmac Studio Controller backup function	Not applicable.
SD Memory Card backup function	Not applicable.
Instructions	Parameters cannot be read or written. An instruction error will occur.
Clearing all memory	Not applicable.
Reading/writing Slave Terminal setting information through backup/restore operations	Not applicable.
Reading event logs	Not applicable.
Notification of status information	Not applicable.

NX Units that are set as unmounted Units are included in the calculations for total power consumption and total Unit width when the Unit configuration is created on the Sysmac Studio.



#### Precautions for Safe Use

Check the user program, data, and parameter settings for proper execution before you use them for actual operation.



#### Precautions for Correct Use

When you mount an NX Unit that was set as an unmounted Unit, a Unit Configuration Verification Error will occur.

## 11-2-4 Setting NX Units as Unmounted Units

You use the Sysmac Studio to set NX Units as unmounted Units. After you change the settings for any NX Units, always transfer the Unit configuration information to the EtherCAT Slave Terminal.

- 1 Select the NX Units to set as unmounted Units from those that are registered to the EtherCAT Coupler Unit on the Edit Slave Terminal Configuration Tab Page. The **Unit Settings Pane** is displayed.

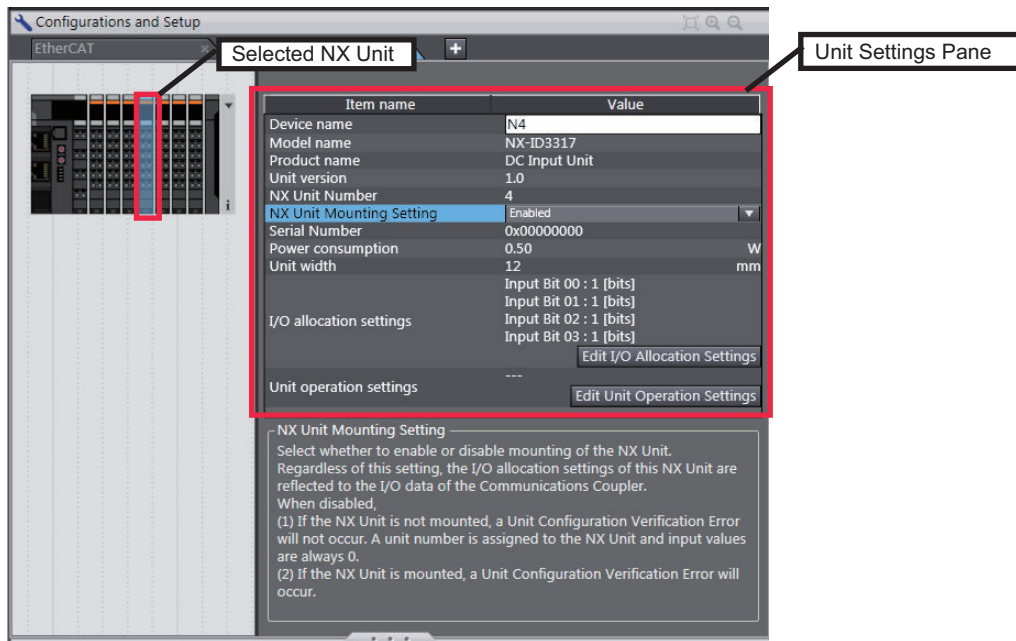

- 2 In the **Unit Setting Pane**, set the **NX Unit Mounting Setting** to **Disabled**. The selected NX Unit is set as an unmounted Unit.

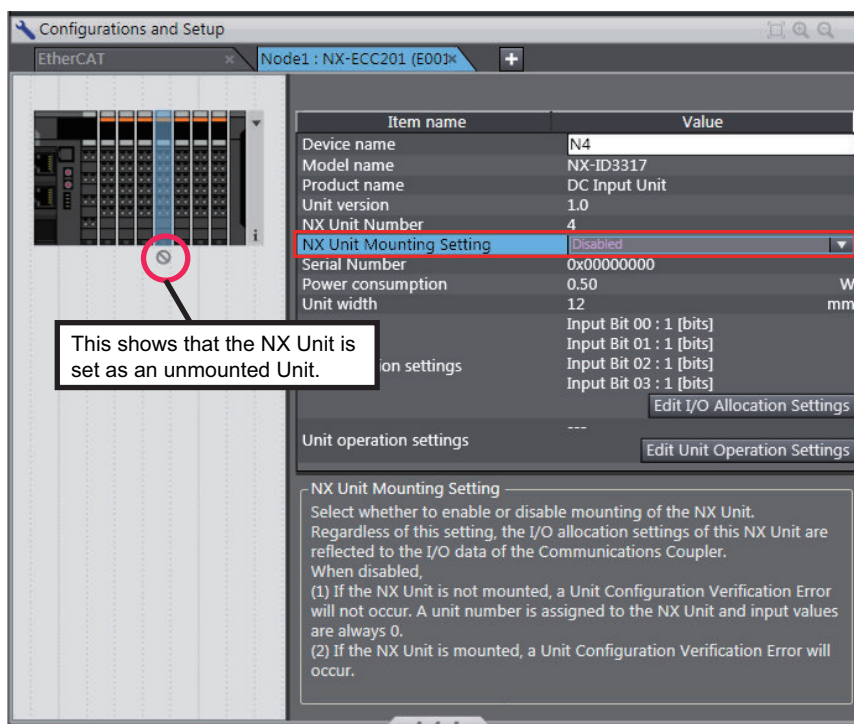

To change an NX Unit that is set as an unmounted Unit to a mounted NX Unit, set the **NX Unit Mounting Setting** to **Enabled** in step 2.

## 11-3 Sysmac Device Functionality Unique to EtherCAT Slaves

“Sysmac devices” is a generic name for EtherCAT slaves and other OMRON control components that were designed with the same communications and user interface specifications.

You can use the EtherCAT Slave Terminals together with NJ/NX/NY-series Machine Automation Controllers and the Sysmac Studio Automation Software to achieve optimum functionality and ease of operation. This is called Sysmac device functionality.

EtherCAT slaves that are Sysmac devices have unique Sysmac device functionality. The EtherCAT Slave Terminal also has unique Sysmac device functionality.

This section describes the unique Sysmac device functionality of EtherCAT slaves.

### ● Troubleshooting with Error Notification through Sysmac Error Status

This function allows the EtherCAT Coupler Unit to use the Sysmac error status, which can be assigned to I/O, to notify the EtherCAT master when an error occurs. This notification acts as a trigger that allows you to use the troubleshooting functions on the Sysmac Studio to view and correct errors that occur in the EtherCAT Slave Terminal.

The Sysmac error status has error level information that is commonly defined for all Sysmac devices.



#### Additional Information

- The Sysmac error status is assigned to I/O by default. Refer to *9-2-4 I/O Allocation Information* on page 9-15 for details on I/O allocations of the Sysmac error status.
- Refer to *13-3 Checking for Errors and Troubleshooting on the Sysmac Studio* on page 13-12 for details on troubleshooting with the Sysmac Studio.

### ● Saving Node Address Settings

This function sets the EtherCAT node addresses on the Sysmac Studio.

If you set the rotary switches and DIP switch pins on the EtherCAT Coupler Unit for the node address to 0, you can use the software setting that is set with the node address setting on the Sysmac Studio.

Place the Sysmac Studio online with the NJ/NX-series CPU or the NY-series Industrial PC to set the node address from the Sysmac Studio. For the procedure to set the node address from the Sysmac Studio, refer to the user’s manual for the built-in EtherCAT port on the connected CPU Unit or Industrial PC.



#### Additional Information

Refer to *4-3 Hardware Switch Settings* on page 4-11 for information on how to set the node address with the rotary switches and DIP switch pins.

### ● Verifying the EtherCAT Network Configuration Using Serial Numbers

Controllers that support Sysmac devices can verify the EtherCAT network configuration based on the serial numbers.

To enable verification, set the **Serial Number Check Method** to **Setting = Actual device** in the **Edit EtherCAT Configuration Edit** Tab Page on the Sysmac Studio.

A Network Configuration Verification Error occurs if the specified standard is not met.

This function detects when the EtherCAT Coupler Unit was replaced so that you can remember to set the parameters for the EtherCAT Coupler Unit.

### ● SII Data Checking

The EtherCAT Coupler Unit checks the information in the SII (slave information interface).

The SII contains setting information that is unique to each EtherCAT slave. It is written to the non-volatile memory in the EtherCAT slave (in the EtherCAT Coupler Unit for an EtherCAT Slave Terminal).

Because the EtherCAT Slave Terminal is a Sysmac device, it checks the SII information at the slave. If the slave contains SII information that prevents it from operating, a Slave Unit Verification Error occurs to inform you that there is an error in the SII data.



#### **Precautions for Correct Use**

---

Do not change the SII information with setting software from other manufacturers.

---

## 11-4 Security

This section describes the subset of *security functions* that are supported by the EtherCAT Slave Terminal, and the specifications that apply to the EtherCAT Slave Terminal. Security is built into the NJ/NX-series CPU Unit or the NY-series Industrial PC.

For information on *security functions*, refer to the software user's manual for the connected CPU Unit or Industrial PC.

### 11-4-1 Supported Security Functions

The following table lists the subset of the security functions that are supported by the EtherCAT Slave Terminal. These *security functions* are built into the NJ/NX-series CPU Unit or the NY-series Industrial PC.

Function	Purpose of function	Remarks
Operation authority verification	Prevention of incorrect operation	---

### 11-4-2 Specifications of Verification of Operation Authority for the EtherCAT Slave Terminal

The authority for operations that affect the EtherCAT Coupler Unit and NX Units are given below.

OK: Operation possible, VR: Verification required for each operation, NP: Operation not possible

Monitoring status	Administrator	Designer	Maintainer	Operator	Observer
Troubleshooting and event logs	OK	OK	OK	OK	OK

I/O monitoring	Administrator	Designer	Maintainer	Operator	Observer
Reading I/O	OK	OK	OK	OK	NP
Writing I/O	OK	OK	OK	VR	NP
Setting/resetting	OK	OK	OK	VR	NP
Forced refreshing (TRUE/FALSE/Clear)	OK	OK	OK	NP	NP

Controller operation	Administrator	Designer	Maintainer	Operator	Observer
RUN mode	OK	OK	VR	NP	NP
PROGRAM mode	OK	OK	VR	NP	NP
Clearing all memory	OK	NP	NP	NP	NP
Resetting Controller	OK	OK	NP	NP	NP
Resetting errors (troubleshooting)	OK	OK	OK	VR	NP
Clearing event logs (troubleshooting)	OK	OK	OK	NP	NP
Restarting	OK	OK	OK	NP	NP

Transfer operation	Adminis- trator	Designer	Main- tainer	Operator	Observ- er
Sysmac Studio synchronization* <sup>1</sup>	OK	OK	OK	NP	NP
Unit operation settings	OK	OK	OK	NP	NP
Transferring data to the Controller from the comput- er					

\*1. For both uploading and downloading.

Backing up and restoring parameters	Adminis- trator	Designer	Main- tainer	Operator	Observ- er
Controller backup, restore, and compare functions	OK	OK	OK	NP	NP
SD Memory Card backup and compare functions	OK	OK	OK	NP	NP
Backing up variables and memory	OK	OK	OK	NP	NP
Restoring variables and memory	OK	OK	NP	NP	NP



#### Precautions for Correct Use

There is no operation authority function if the Sysmac Studio is connected to the EtherCAT Coupler Unit directly through the peripheral USB port.

## 11-5 Event Logs

The EtherCAT Slave Terminal supports the event logs of NJ/NX/NY-series Controllers. This allows you to use the NJ/NX/NY-series Controller to perform troubleshooting.

This section describes event logging for EtherCAT Slave Terminals.

Refer to the troubleshooting manual for the connected CPU Unit or Industrial PC for information on troubleshooting the overall NJ/NX-series Controller.

### 11-5-1 Introduction

The EtherCAT Slave Terminal records events, such as errors and status changes, that occur in the EtherCAT Slave Terminal. You can use the Sysmac Studio to check the meaning of the events in the EtherCAT Slave Terminals.

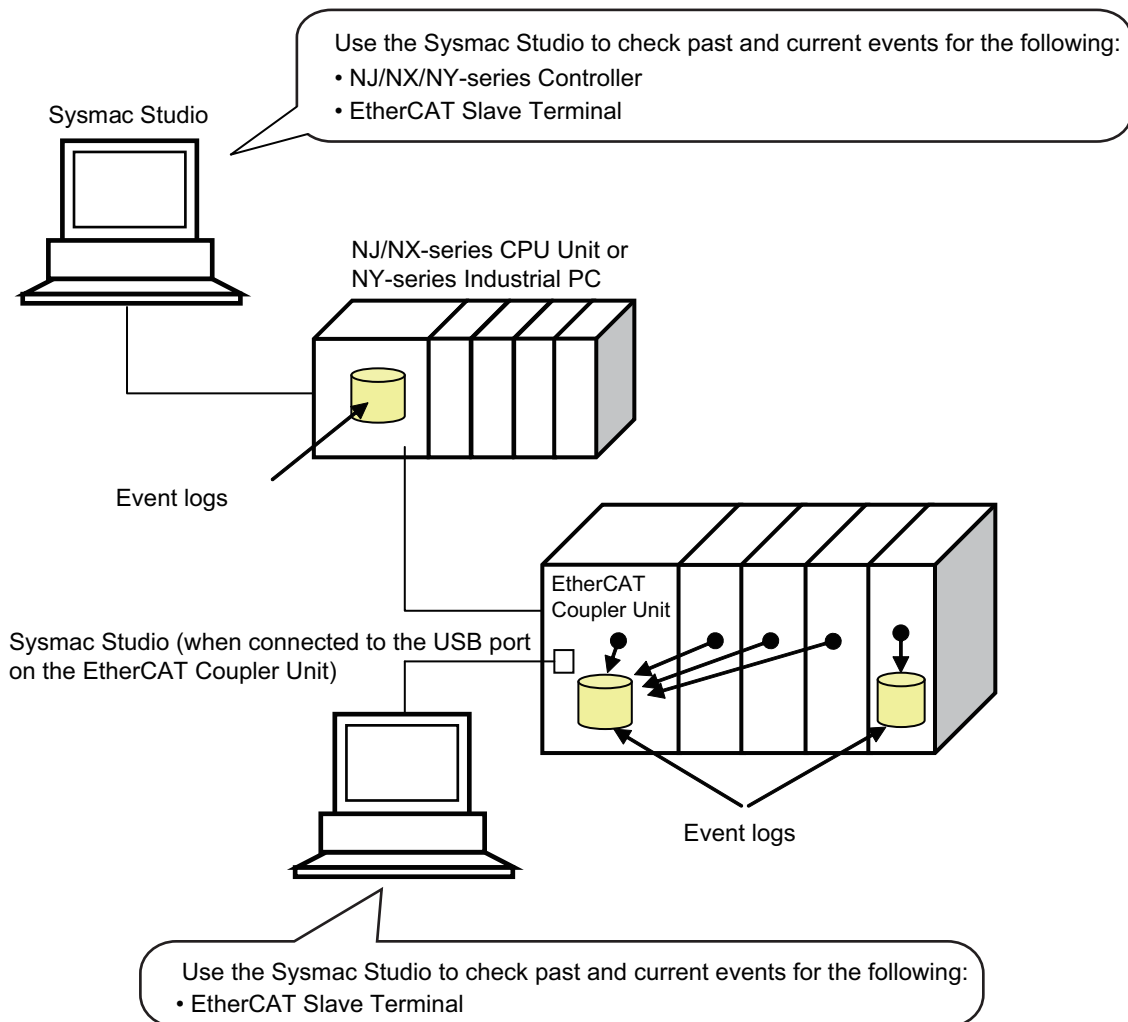

*Event* for an EtherCAT Slave Terminal is a generic term for an unexpected error or for information that does not indicate an error but for which the user must be notified.

## Features

Event logging in the EtherCAT Slave Terminal offers the same benefits that apply to NJ/NX/NY-series Controllers.

- In addition to error logs, various logs are recorded, such as execution of restarting.
- This allows you to check events based on time, which can help you isolate the causes of errors when problems occur.

## Displaying Event Logs

You can use the troubleshooting functions on the Sysmac Studio to check current and past events in an EtherCAT Slave Terminal.



### Additional Information

Refer to the appendices of the troubleshooting manual for the connected CPU Unit or Industrial PC for the specifications for checking EtherCAT Slave Terminal errors on an OMRON HMI.

## 11-5-2 Detailed Information on Event Logs

This section describes the event logs in detail.

## Where Events Are Stored

Events that occur in the EtherCAT Slave Terminal are stored as described below.

Unit where event occurred	Where events are stored
EtherCAT Coupler Unit	In the EtherCAT Coupler Unit
NX Units	In the EtherCAT Coupler Unit or in the NX Unit For the location where events are stored, refer to <i>Current Errors</i> and <i>Log of Past Errors</i> in <i>Troubleshooting</i> in the user's manuals for the NX Units to check the specifications.

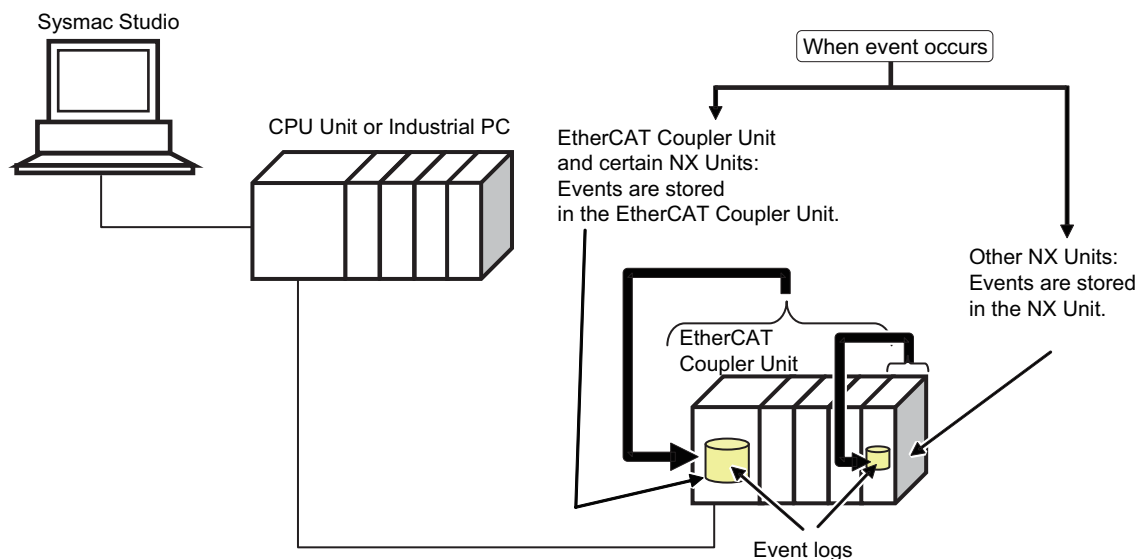

## Event Sources

The sources of events that occur in the EtherCAT Slave Terminal are listed below.

Item	Description
Event source	EtherCAT Master Function Module
Source details	EtherCAT node address, slot position, NX Unit number, and model number

## Event Log Categories

This information gives the category of the event log.

You view each of these logs separately on the Sysmac Studio.

Event type	Event log category	Description
Controller event	System log	This is a log of the events that are detected by each Unit.
	Access log	This is a log of the events that affect the Slave Terminal operation due to user actions.

## Number of Records

Each event log can contain the following number of records. If the number of events exceeds this number, the oldest events are overwritten.

Event log category	Unit type		
	EtherCAT Coupler Unit	NX Unit	
		Units that store events in the EtherCAT Coupler Unit	Units that store their own events
System event log	Total: 128 events	Refer to <i>Current Errors</i> and <i>Log of Past Errors</i> in <i>Troubleshooting</i> in the user's manual for each Unit to check the specifications.	
Access event log	Total: 32 events		

## Retaining Event Logs during Power Interruptions

The EtherCAT Slave Terminal retains event logs even if the Unit power supply is interrupted.

## Event Codes

Event codes are pre-assigned to the events based on the type of event. Event codes are displayed as 8-digit hexadecimal numbers.

Refer to *13-3-2 Event Codes for Errors and Troubleshooting Procedures* on page 13-14 for details on event codes and error meanings.



### Additional Information

When the power supply is turned ON, the EtherCAT Coupler Unit enters the Pre-Operational state. It then resets any current errors and detects errors again. Therefore, the same error may be recorded more than once in the event log of the EtherCAT Slave Terminal. This applies to the following errors.

- Errors that occurred before the power supply to the EtherCAT Slave Terminal was cycled for which the causes of the errors remain.
- Errors that occur after the power supply to the EtherCAT Slave Terminal is turned ON but before it moves to the Pre-Operational state

## Event Levels

Each event has an *event level*.

Events are classified into the following five levels according to the level of impact the events have on control.

No.	Event level	Classification
1	High	Major fault
2		Partial fault level
3		Minor fault level
4		Observation level
5	Low	Information level

Errors with a higher level have a greater impact on the functions that the NJ/NX/NY-series Controller provides, and are more difficult to recover from. These classifications are displayed on the Sysmac Studio when an error occurs.

You can change the level assigned to some events. Refer to *11-8 Changing Event Levels* on page 11-29.

## Clock Information

The time at which an error occurs in the EtherCAT Slave Terminal is recorded based on the time information from the clock built in the CPU Unit or Industrial PC, which is retrieved from the NJ/NX/NY-series Controller.

If the clock information cannot be retrieved from the NJ/NX/NY-series Controller, the time on the Sysmac Studio is displayed as ----/--/-- --:--:--. The times of events that occur before the time is retrieved from the NJ/NX/NY-series Controller are also displayed as ----/--/-- --:--:--.



### Version Information

If the time information cannot be obtained from the NJ/NX/NY-series Controller or if an event occurs before the time information is obtained from the NJ/NX/NY-series Controller, the time of event occurrence was given as *1970/1/1 0:00:00* for Sysmac Studio version 1.14 or lower.

### 11-5-3 Reading Event Logs

Use the following procedure to read the event log.

- 1 Select **Troubleshooting** from the **Tools** Menu while online. You can also click the **Troubleshooting** Button in the toolbar. The following **Troubleshooting** Dialog Box is displayed.

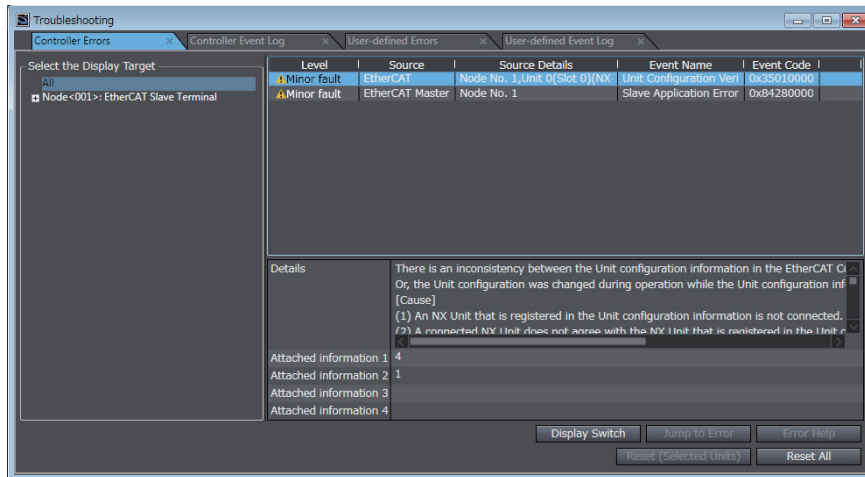

- 2 Click the **Controller Event Log** Tab Page. The event log for the EtherCAT Coupler Unit is displayed. Click the **Update** Button to display the latest event log. If an event is for a Slave Terminal, the node number of the Slave Terminal and the NX Unit number are displayed as the source details.

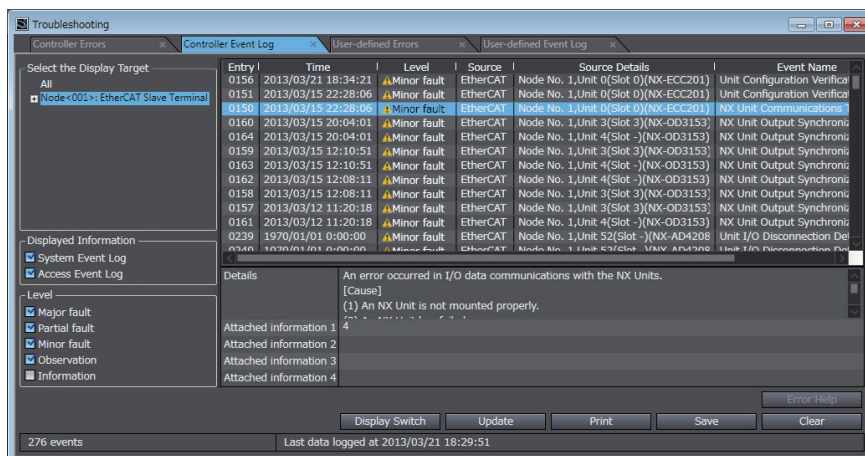



### Additional Information

- The NX Unit numbers that are displayed as the source in the event log are the NX Unit numbers in the current Unit configuration. They are not necessarily the NX Unit numbers at the time that the event occurred.
- You can check the NX Unit event log that is stored in the EtherCAT Coupler Unit for NX Units that are no longer mounted under the EtherCAT Coupler Unit. To check them, select everything or select the EtherCAT Slave Terminal in the **Select the Display Target** from the **Controller Event Log** Tab Page. The event log display will also include NX Units that were previously mounted to the EtherCAT Coupler Unit. For these NX Units, the NX Unit number is the number when the error occurred.  
To display the event log for only the currently mounted NX Units, select the NX Units in the **Select the Display Target**.
- If the most recent version of the Sysmac Studio is not used, the Sysmac Studio may not support some events. If unsupported events occur, *Unknown* is given for the source and *Unknown Event* is given for the event name. The event code and attached information are displayed correctly.  
Use the most recent version of the Sysmac Studio to check events.

## 11-5-4 Clearing Event Logs

You can clear the event logs in the EtherCAT Slave Terminal. This section describes how to clear the event logs.

### Specifying the Scope of Event Logs to Clear

You can specify whether to clear events from the entire EtherCAT Slave Terminal, the EtherCAT Coupler Unit, or the NX Units.

Sysmac Studio connection	Unit to clear log from	
	Clearing event logs in the entire EtherCAT Slave Terminal at once	Clearing events for specific Units
NJ/NX-series CPU Unit or NY-series Industrial PC	<ul style="list-style-type: none"> <li>• Entire Controller</li> <li>• EtherCAT Slave Terminal</li> </ul>	<ul style="list-style-type: none"> <li>• EtherCAT Coupler Unit</li> <li>• NX Units</li> </ul>
Peripheral USB port on EtherCAT Coupler Unit	<ul style="list-style-type: none"> <li>• EtherCAT Slave Terminal</li> </ul>	

## Procedure for Clearing Event Logs

From the Controller Event Log Tab Page, you can clear the events for an entire Slave Terminal or the events for a specified EtherCAT Coupler Unit or NX Unit.

- 1 Select **Troubleshooting** from the **Tools** Menu while online. You can also click the **Troubleshooting** Button in the toolbar. The following **Troubleshooting** Dialog Box is displayed.

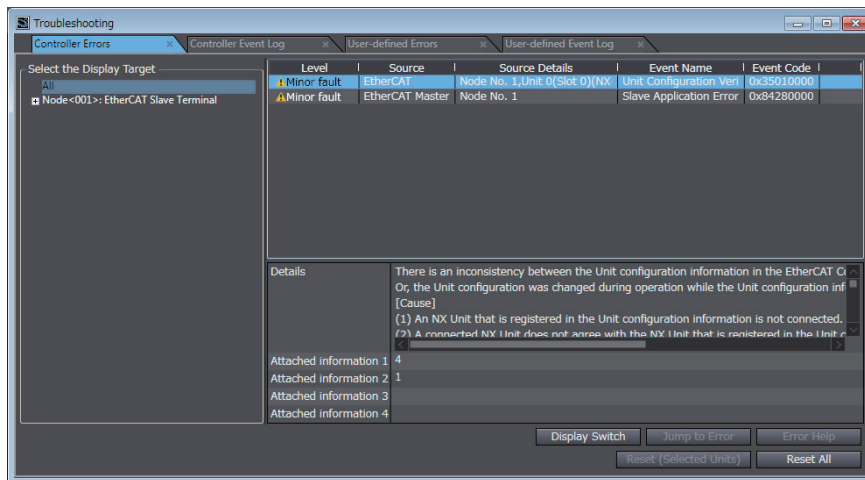

- 2 In the **Select the Display Target** Area of the **Controller Event Log** Tab Page, select the Units to clear and click the **Clear** Button.

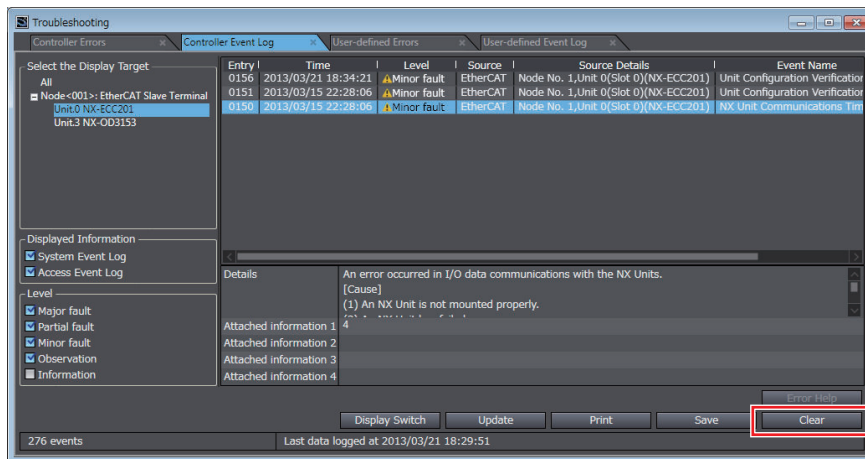

A confirmation dialog box is displayed.

- 3 Click the **Yes** Button. The selected events are cleared.

## 11-5-5 Exporting the Event Log

You can export the contents of the event log to a CSV file.

The event log for the EtherCAT Coupler Unit and NX Units is displayed as part of the Controller event log. Use the Sysmac Studio.

- 1 Select **Troubleshooting** from the **Tools** Menu while online. You can also click the **Troubleshooting** Button in the toolbar.

The following **Troubleshooting** Dialog Box is displayed.

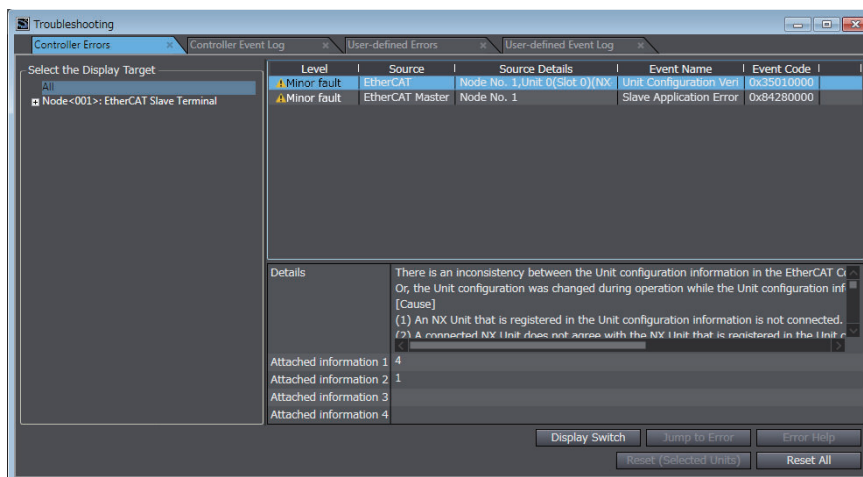

- 2 In the **Select the Display Target** Area of the **Controller Event Log** Tab Page, select the Unit for which to export the events and click the **Save** Button.

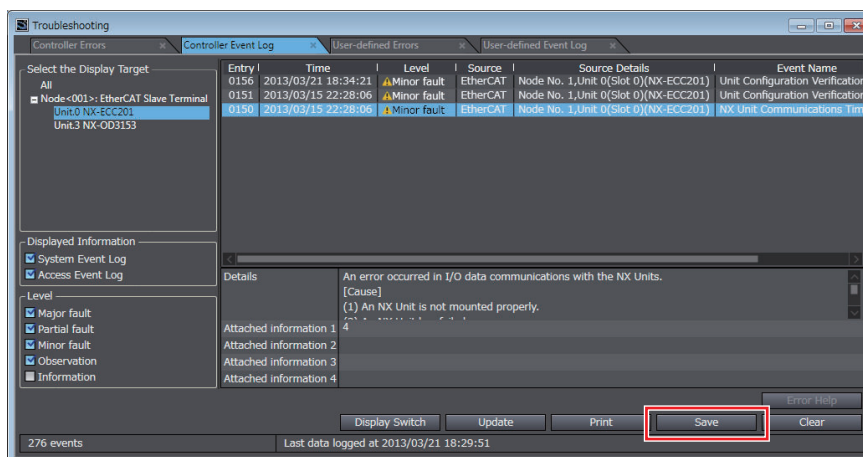

The Save Dialog Box is displayed.

- 3 Input the file name, and then click the **Save** Button.  
The Controller event logs are saved in CSV format.

## 11-6 Clearing All Memory

This section describes how to clear all memory in the EtherCAT Slave Terminals.

This procedure is not used to clear all memory in the Safety Control Units. Refer to the *NX-series Safety Control Unit User's Manual (Cat. No. Z930)* for the procedure for the Clear All Memory operation for the Safety Control Units.

### 11-6-1 Introduction

The clear all memory function initializes various setting information in the EtherCAT Slave Terminal to the default settings, such as the Unit configuration information and the I/O allocation information. You can use this function on the Sysmac Studio to initialize various setting information.

### 11-6-2 Details on Clearing All Memory

#### Specifying the Scope of Memory to Clear

You can specify the scope of the memory to clear from the following.

- EtherCAT Slave Terminal
- EtherCAT Coupler Unit
- NX Units



#### Additional Information

Even if you clear all memory on the NJ/NX-series CPU Unit or NY-series Industrial PC, the memory in the EtherCAT Slave Terminal is not cleared.

#### Scope of Data to Clear and State of Memory After It Is Cleared

The function clears the following data in the EtherCAT Slave Terminal.

Data	Status after Clear All Memory operation for each specification		
	Entire EtherCAT Slave Terminal	EtherCAT Coupler Unit	NX Unit
Unit configuration information	This data is set to the default settings. If you turn ON the Unit power supply immediately after the Clear All Memory operation is completed, the Slave Terminal starts based on the actual Unit configuration information.	The data is not cleared.	The data is not cleared.
I/O allocation information	This data is set to the default settings.	The data is not cleared.	The data is not cleared.
Unit operation settings	This data is set to the default settings.	This data is set to the default settings.	This data is set to the default settings.

Data	Status after Clear All Memory operation for each specification		
	Entire EtherCAT Slave Terminal	EtherCAT Coupler Unit	NX Unit
Unit application data	Refer to the manual for each NX Unit for the operating specifications when the Clear All Memory operation is used on NX Units that have Unit application data.	---	Refer to the manual for each NX Unit for the operating specifications when the Clear All Memory operation is used on NX Units that have Unit application data.
Event logs	Event logs are cleared if you select the Clear event log Option when you execute the Clear All Memory operation.	Event logs are cleared if you select the Clear event log Option when you execute the Clear All Memory operation.	Event logs are cleared if you select the Clear event log Option when you execute the Clear All Memory operation.

## Restarting after Clear All Memory Operation

Restarting is performed after the Clear All Memory operation.

The following table gives the target of the Clear All Memory operation and the type of restart that is performed after the Clear All Memory operation.

Target of Clear All Memory operation	Type of restart
Entire EtherCAT Slave Terminal	Restarting the Slave Terminal.
EtherCAT Coupler Unit	Restarting the Slave Terminal.
NX Unit	Restarting the Slave Terminal or the NX Unit.* <sup>1</sup>

- \*1. The function to restart individual NX Units was added for a version upgrade.  
 The NX Unit is restarted if the unit versions of the EtherCAT Coupler Unit and the NX Unit support restarting individual NX Units.  
 The Slave Terminal is restarted if the unit version of either the EtherCAT Coupler Unit or the NX Unit does not support restarting individual NX Units.  
 Refer to *A-11-2 Functions That Were Added or Changed for Each Unit Version* on page A-103 for the versions that support restarting individual NX Units.

### 11-6-3 Procedure for Clearing All Memory

Use the following procedure to clear all of the memory in the Slave Terminal.

Use the Sysmac Studio.

- 1** Connect the computer on which the Sysmac Studio is installed through the NJ/NX-series CPU Unit or NY-series Industrial PC or to the peripheral USB port on the EtherCAT Coupler Unit and go online.
- 2** Right-click the Unit on the Edit Slave Terminal Configuration Tab Page and select **Clear All Memory**. To clear the memory in all Units, right-click the EtherCAT Coupler Unit and select **Clear All Memory**.  
 The **Clear All Memory** Dialog Box is displayed.

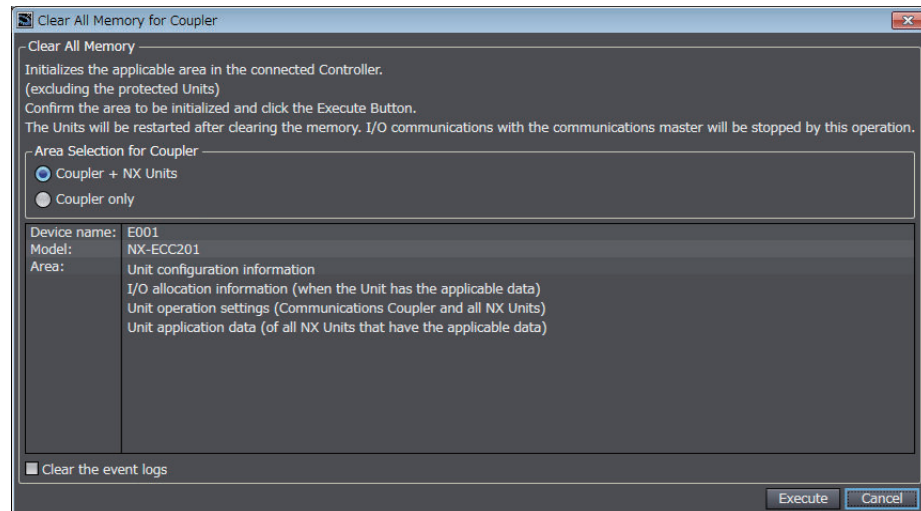

- 3 Check the areas to clear and then click the **Execute** Button.
  - To clear the event log, select the **Clear the event logs** Check Box.
  - To clear the memory in all Units, select the **Coupler + NX Units** Option in the *Area Selection for Coupler* Area.

An execution confirmation dialog box is displayed.

- 4 Click the **Yes** Button.
 

After memory is cleared, the Memory All Cleared Dialog Box is displayed.



#### Precautions for Correct Use

Refer to the manuals for the specific Units for details on the areas that are cleared and the status after memory is cleared.

# 11-7 Restarting

This section describes restarting an EtherCAT Slave Terminal.

## 11-7-1 Introduction

The restart function is used to apply changes to settings with the Sysmac Studio or by executing instructions without cycling the Unit power supply to the EtherCAT Slave Terminal.

## 11-7-2 Details on Restarting

This section describes the types of restarts: Restarting the Slave Terminal and restarting individual NX Units.

### Types of Restarts

The following table gives the types of restarts.

Type	Function
Restarting Slave Terminal	The EtherCAT Coupler Unit and all NX Units mounted to the Slave Terminal are restarted.
Restarting individual NX Units	The specified NX Unit is restarted.



#### Version Information

The function to restart individual NX Units was added for a version upgrade. Refer to *A-11-2 Functions That Were Added or Changed for Each Unit Version* on page A-103 for the versions that support restarting individual NX Units.

### Restarting Slave Terminals

The EtherCAT Coupler Unit and all NX Units mounted to the Slave Terminal are restarted. Select the EtherCAT Coupler Unit of the EtherCAT Slave Terminal to restart and then execute the restart.

The methods for restarting are listed below.

- Sysmac Studio
- RestartNXUnit (Restart NX Unit) instruction

Refer to the instructions reference manual for the connected CPU Unit or Industrial PC for information on the RestartNXUnit instruction.



### Precautions for Correct Use

- The EtherCAT master may detect an error when the Slave Terminal is restarted after a restart operation is performed with a direct USB connection between the Sysmac Studio and EtherCAT Coupler Unit. If an error is detected, you need to reset the error in the EtherCAT master.
- When the Slave Terminal is restarted, all of the Units on the Slave Terminal perform the same operation as when the power supply is cycled. Refer to the manuals for the specific Units for the operation that is performed when the power supply is turned ON.

## Restarting Individual NX Units

One specified NX Unit is restarted.

The methods for restarting an NX Unit are listed below.

- Sysmac Studio
- RestartNXUnit (Restart NX Unit) instruction

Refer to the instructions reference manual for the connected CPU Unit or Industrial PC for information on the RestartNXUnit instruction.

The EtherCAT Coupler Unit and all NX Units that were not specified for restarting continue to operate.

### 11-7-3 Procedure for Restarting

This section gives the restart procedures for the Sysmac Studio.

## Restarting the Slave Terminal

Use the following procedure to restart all of the Units in the Slave Terminal.

- 1 Go online, right-click the EtherCAT Coupler Unit in the Edit Slave Terminal Configuration Tab Page, and select **Restart**.  
A Restart Confirmation Dialog Box is displayed.

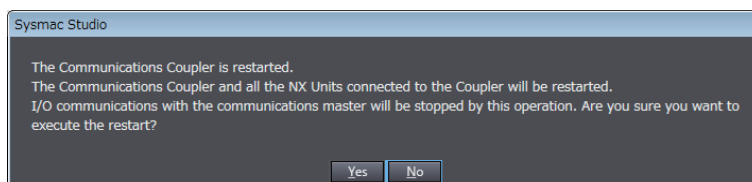

- 2 Click the **Yes** Button.  
After the Units are restarted, a Restart Completion Dialog Box is displayed.

## Restarting an NX Unit

---

Use the following procedure to restart an NX Unit.

- 1** Go online, right-click the NX Unit to restart in the Edit Slave Terminal Configuration Tab Page, and select **Restart**.  
A Restart Confirmation Dialog Box is displayed.

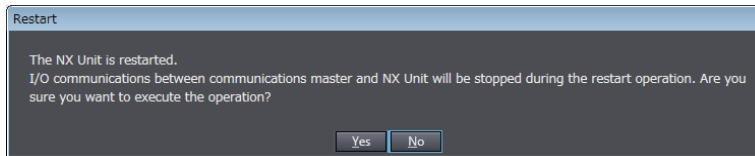

- 2** Click the **Yes** Button.  
After the Unit is restarted, a Restart Completion Dialog Box is displayed.

## 11-8 Changing Event Levels

This section describes changing event levels for the EtherCAT Slave Terminals.

### 11-8-1 Introduction

You can change the event levels that are assigned to each Controller event.

### 11-8-2 Details on Changing Event Levels

#### Unit of Event Level Settings

Levels are set for each event in each Unit. If the same event code occurs in more than one Unit, you can set a different event level for each Unit.

#### Events with Changeable Levels

- **EtherCAT Coupler Unit**

The EtherCAT Coupler Unit does not have events for which you can change the event level.

- **NX Units**

For events for which you can change the event level in each NX Unit, refer to *Error Event Codes and Troubleshooting* or *Event Codes and Corrections for Errors* in the *Troubleshooting* section of the user's manual for the NX Unit.

#### When Changes Take Effect

Changes to the event levels take effect only after they are downloaded and the Unit power supply is cycled or the Units are restarted.



#### Additional Information

##### Changing the Event Levels for Current Errors

The event levels of current errors do not change when the event level settings are changed and downloaded. You must restart the EtherCAT Coupler Unit or cycle the Unit power supply to enable the changes.

### 11-8-3 Procedure to Change an Event Level

Use the Sysmac Studio to change an event level.

After you change an event level, always transfer the operation settings to the Controller.

- 1 On the Edit Slave Terminal Configuration Tab Page, select the Unit for which to change the event level and click the **Unit Operation Settings** Button.  
The Edit Unit Operation Settings Tab Page is displayed.

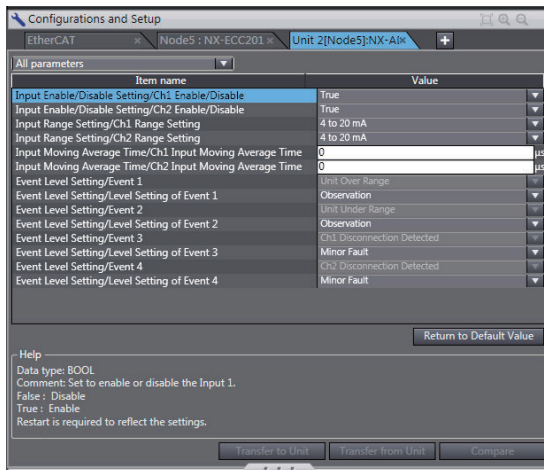

- 2 From the events for which *Level setting* is displayed, select the event for which you want to change the level, and then select a level from the list in the Value field.

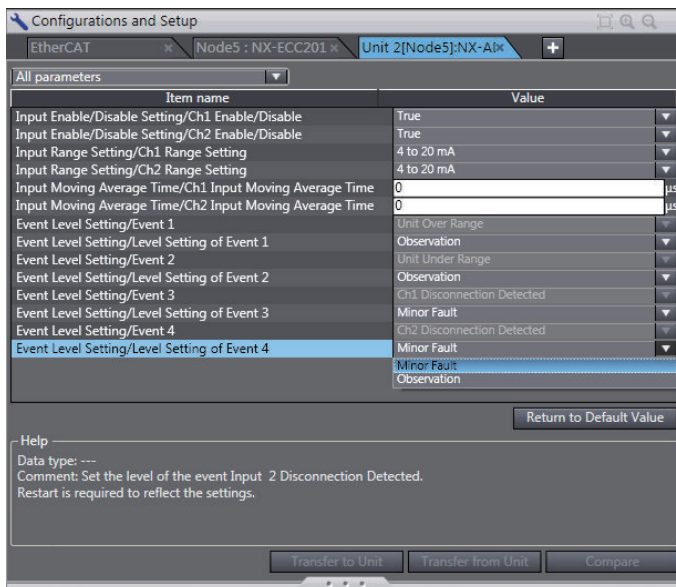

- 3 After you make the change, go online and click the **Transfer to Unit** Button to transfer the change to the Controller.  
The specified event level is changed.

There are no events for the EtherCAT Coupler Unit for which you can change the event level. If there are Controller events for which you can change the event level in an NX Unit, they will be given in the manual for the NX Unit. Refer to *Error Event Codes and Troubleshooting* or *Event Codes and Corrections for Errors* in the *Troubleshooting* section of the user's manual for the NX Unit.



### Precautions for Correct Use

If you change the event level of a Controller error, the output status when the error occurs may also change. Confirm safety before you change an event level.

# 11-9 Resetting Errors

This section describes how to reset errors that occur in the EtherCAT Slave Terminal.

## 11-9-1 Introduction

The error reset function is used to change the error status of a target EtherCAT Slave Terminal to a normal state.

## 11-9-2 Details on Resetting Errors

### Error Reset Methods

Refer to *13-4 Resetting Errors* on page 13-53 for the error reset methods.

### Methods and Specified Range for Resetting Errors

The following table describes how to reset errors in the EtherCAT Slave Terminal from the Sysmac Studio, and gives the range of errors that you can reset.

Sysmac Studio connection	Batch reset	Individual reset
NJ/NX-series CPU Unit or NY-series Industrial PC	Resets all error in the Controller. This includes resetting errors in the EtherCAT Slave Terminal.	Resets errors in the specified Unit.
Peripheral USB port on EtherCAT Coupler Unit	Resets all errors in the EtherCAT Slave Terminal.	

With Safety Control Units, you may have to reset some errors by accessing safety programs, depending on the contents of the errors. Refer to the *NX-series Safety Control Unit User's Manual (Cat. No. Z930)* for information on resetting errors for Safety Control Units.



#### Additional Information

Refer to the appendices of the troubleshooting manual for the connected CPU Unit or Industrial PC for the specified ranges to use when resetting errors from an OMRON HMI.

### 11-9-3 Procedure to Reset Errors

The current errors and the contents of the event logs in the online Controller are read and reset in the **Troubleshooting** Dialog Box. Use the Sysmac Studio.

#### Resetting Errors Individually in Units in the EtherCAT Slave Terminal

- 1 Connect the computer on which the Sysmac Studio is installed through the NJ/NX-series CPU Unit or NY-series Industrial PC or to the peripheral USB port on the EtherCAT Coupler Unit and go online.
- 2 Select **Troubleshooting** from the **Tools** Menu while online. You can also click the **Troubleshooting** Button in the toolbar. The following **Troubleshooting** Dialog Box is displayed.

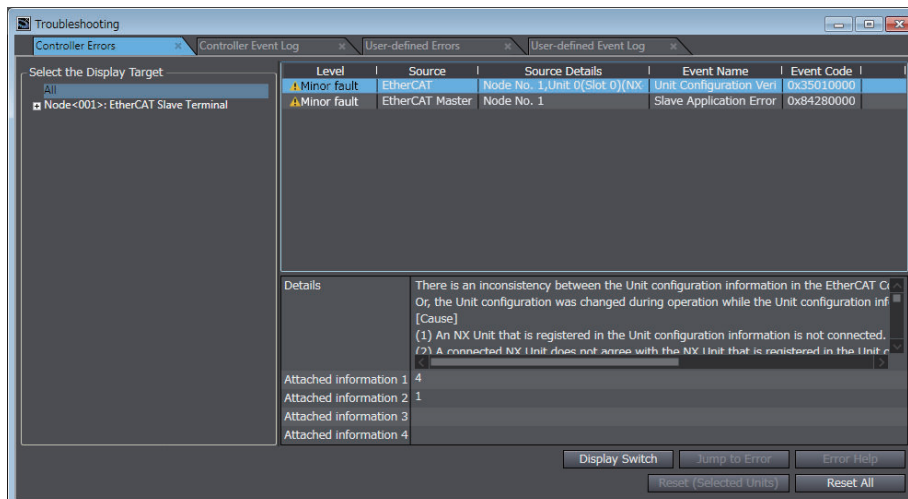

The current Controller errors are displayed on the **Controller Errors** Tab Page. (Observations and information are not displayed.)

- 3 In the **Select the Display Target** of the **Controller Errors** Tab Page, select the Unit for which to reset the errors and click the **Reset (Selected Units)** Button.

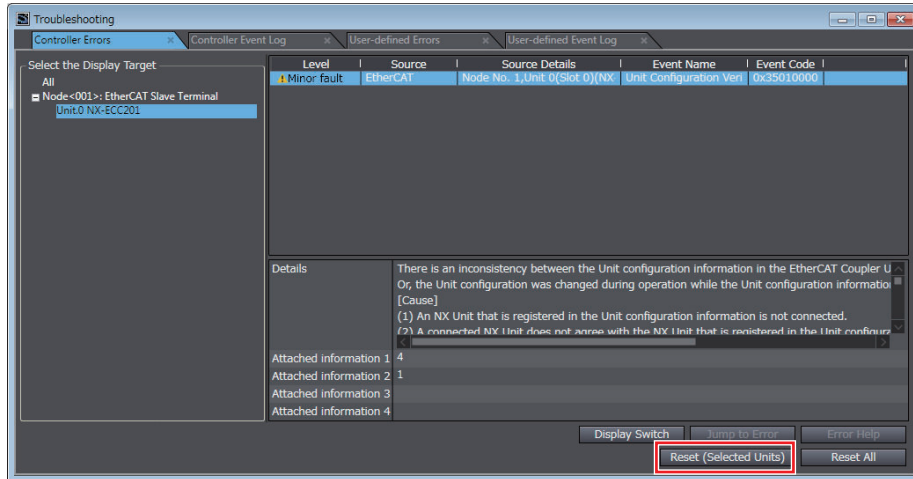

The errors in the selected NX Unit are reset.



### Additional Information

If you select the EtherCAT Slave Terminal or EtherCAT Coupler Unit, errors are reset for the entire EtherCAT Slave Terminal.

## Resetting the Errors in All Units in the EtherCAT Slave Terminal at the Same Time

- 1 Connect the computer on which the Sysmac Studio is installed through the NJ/NX-series CPU Unit or NY-series Industrial PC or to the peripheral USB port on the EtherCAT Coupler Unit and go online.
- 2 Select **Troubleshooting** from the **Tools** Menu while online. You can also click the **Troubleshooting** Button in the toolbar.  
The following **Troubleshooting** Dialog Box is displayed.

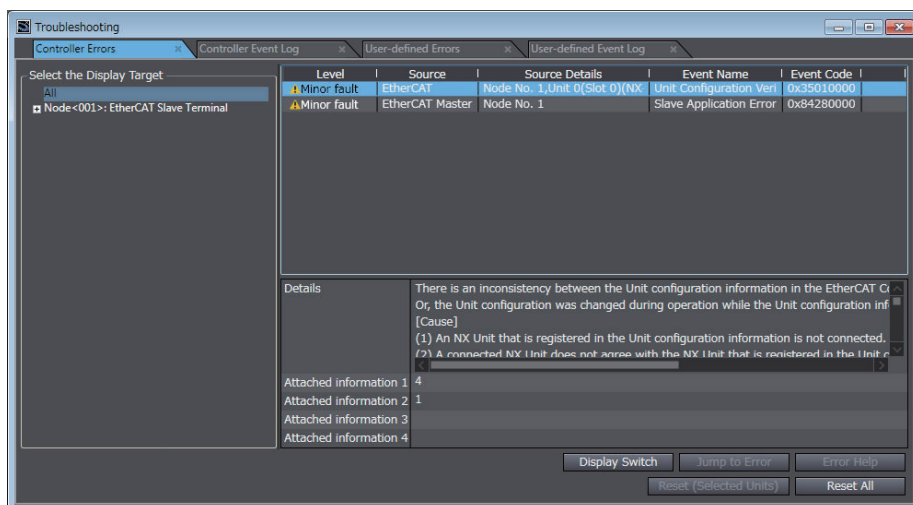

The current Controller errors are displayed on the **Controller Errors** Tab Page. (Observations and information are not displayed.)

- 3** Click the **Reset All** Button.  
The errors are reset. Any errors for which the causes remain are displayed again.

# 11-10 I/O Checking

This section describes how to check I/O for an EtherCAT Slave Terminal.



## Version Information

The function for I/O checking was added for a version upgrade. Refer to *A-11-2 Functions That Were Added or Changed for Each Unit Version* on page A-103 for the versions that support I/O checking.

## 11-10-1 Overview

This function allows you to check the wiring between NX Units and I/O devices from the Sysmac Studio connected to the peripheral USB port on the EtherCAT Coupler Unit.

You can monitor inputs to NX Units and change the output values from NX Units.

This allows you to check wiring in the following cases.

- You can check the wiring between NX Units and I/O devices in advance during system commissioning when the CPU Unit is temporarily not available.
- You can check the wiring between NX Units and I/O devices in advance during system commissioning when EtherCAT network wiring is not completed.
- You can check wiring between the NX Units and I/O devices from close to the EtherCAT Slave Terminal.
- More than one person can simultaneously check wiring between the NX Units and I/O devices when there is more than one EtherCAT Slave Terminal.

## 11-10-2 Details on I/O Checking

This section describes I/O checking in detail.

You can use I/O checking to perform the following for EtherCAT Slave Terminal inputs and outputs that are displayed as I/O ports on the Sysmac Studio.

Item	Function
Inputs	You can monitor the values of inputs to a Unit.
Outputs	You can output specified values from Units.

However, for Position Interface Units and other NX Units that are assigned to axes, you can monitor the input values but you cannot output values. If an axis is assigned to an NX Unit, use the MC Test Run or axis status monitoring (MC Monitor Table) of the Sysmac Studio instead of I/O checking to check wiring.

I/O checking cannot be used for some models or unit versions of the NX Unit. Refer to *Support Functions of the Communications Coupler Units and Restrictions on the NX Units* of the *NX-series Data Reference Manual (Cat. No. W525)* for the restrictions on NX Units.

## Range of Application of I/O Checking

I/O checking is applicable to an EtherCAT Slave Terminal that is online with the Sysmac Studio that is connected to the peripheral USB port of the EtherCAT Coupler Unit. You cannot use I/O checking for any Units that are not connected to the Sysmac Studio, such as a CPU Unit, an Industrial PC, or other EtherCAT slaves including other EtherCAT Slave Terminals.

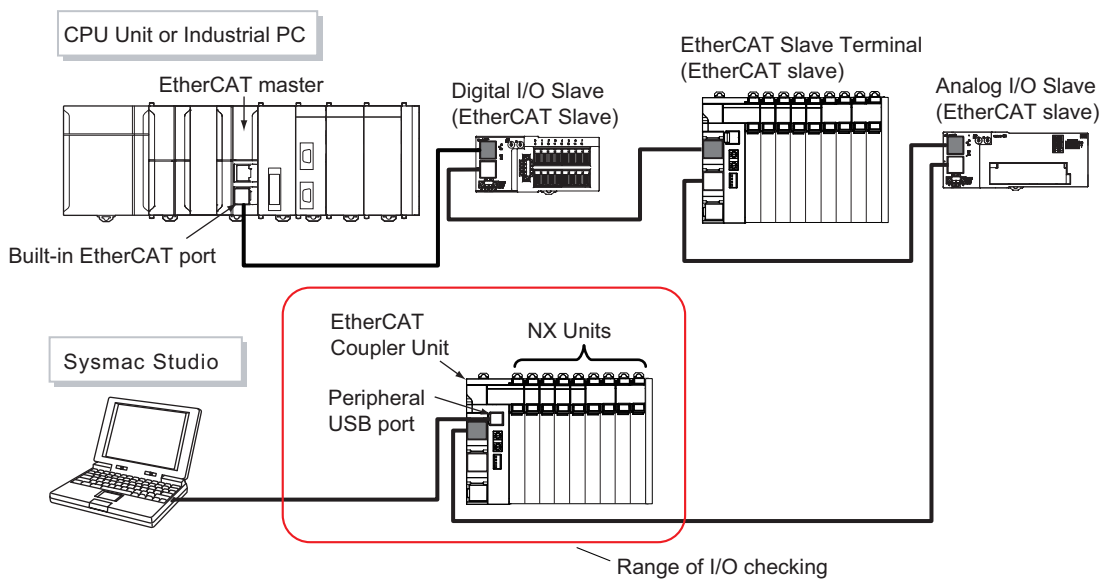

## I/O Checking Operation Specifications

This section gives the operation specifications of I/O checking.

### ● Conditions for Starting I/O Checking

To start I/O checking, the following conditions must be met for the EtherCAT Slave Terminal. You cannot start I/O checking unless all of these conditions are met.

- Communications with the EtherCAT master must be stopped.
- The Unit configuration information in the EtherCAT Coupler Unit must match the actual configuration.
- The Unit configuration information in the Sysmac Studio project must match the actual configuration.
- There must be no current errors. <sup>\*1</sup>

\*1. I/O checking can be started even when an NX Unit Initialization Error has occurred during fail-soft operation. However, you cannot use I/O checking for any NX Unit where there is an NX Unit Initialization Error.

### ● Indicator Status during I/O Checking

The following table shows the indicator status during I/O checking when the EtherCAT Slave Terminal is in normal status.

Indicator	Indicator status on EtherCAT Coupler Unit	Indicator status on NX Units*1
TS	Flashing green at 0.5-s intervals.	Lit green.
UNIT PWR	Lit green.	Lit green.
I/O PWR	Lit green.	Lit green.
L/A IN	Not lit.	---
L/A OUT	Not lit.	---
RUN	Not lit.	---
ERR	Not lit.	---
Signal I/O status indicators	---	The current I/O status is shown.

\*1. The indicator status is given for Units that have the relevant indicators.

### ● Operation Specifications for Interference during I/O Checking

The following table gives the operation specifications for when errors or other interference occurs during I/O checking.

Interference	Operation specifications
Bus Controller Error	I/O checking cannot be continued. The outputs from the EtherCAT Slave Terminal will follow the output values at load rejection.
Unit Configuration Verification Error	I/O checking is continued during fail-soft operation. However, you cannot use I/O checking for an NX Unit that cannot operate normally. I/O checking is not continued if fail-soft operation is not used. The outputs from the EtherCAT Slave Terminal will follow the output values at load rejection.
NX Message Communications Error	I/O checking can be continued. However, you cannot use I/O checking for an NX Unit that has a current error.
Disconnection of communications between Sysmac Studio and EtherCAT Slave Terminal	Such as when USB cable is disconnected The EtherCAT Slave Terminal continues I/O checking. The current values output by the EtherCAT Slave Terminal will continue. The Sysmac Studio will remain in an online status. When the Sysmac Studio is connected to the EtherCAT Coupler Unit, it will go online and you can continue I/O checking.
Unit power supply to EtherCAT Coupler Unit is turned OFF.	I/O checking cannot be continued.

If an error occurs in the EtherCAT Slave Terminal during I/O checking, the error is recorded in the event log. The indicators will show the error.

### ● I/O Checking for Unmounted Units

You cannot use I/O checking for an NX Unit that is set as an unmounted Unit in the NX Unit Mounting Setting.

## 11-10-3 Procedure Required before I/O Checking

This section describes the procedure that is required before you can start I/O checking. To start I/O checking, the conditions to start I/O checking must be met. For the specific conditions to start I/O checking, refer to *Conditions for Starting I/O Checking* on page 11-36.

The procedure depends on whether you have already transferred the Slave Terminal setting information to the EtherCAT Slave Terminal.

## Procedure When the Slave Terminal Setting Information Was Not Previously Transferred

Use the following procedure when you have not transferred the Slave Terminal setting information to the EtherCAT Slave Terminal. You do not have to perform the following procedure if you have already transferred the settings information with the procedure given in *3-2 Procedures* on page 3-7.

- 1** Perform steps 1 to 4 in *3-2 Procedures* on page 3-7. However, do not wire the communications cables. Also, you do not necessarily have to create the Unit application data.
- 2** Turn ON the Unit power supply and I/O power supply to the EtherCAT Slave Terminal.
- 3** Connect the Sysmac Studio to the peripheral USB port on the EtherCAT Coupler Unit and place it online.
- 4** Use the compare and merge operation for the physical configurations to see if the EtherCAT Slave Terminal Unit configuration that is set on the Sysmac Studio agrees with the actual configuration.  
Refer to *Comparing and Merging with Actual Unit Configuration of the Slave Terminal* on page 9-29 for information on comparing and merging with the actual configuration.
- 5** Transfer the Slave Terminal setting information to the EtherCAT Slave Terminal.  
Refer to *A-2-3 Transferring Slave Terminal Setting Information through the USB Port on the EtherCAT Coupler Unit* on page A-8 for the transfer procedure.

After you perform the above procedure and complete I/O checking, perform the remaining procedures in *3-2 Procedures* on page 3-7 to commission the EtherCAT Slave Terminal.

## Procedure When the Slave Terminal Setting Information Was Previously Transferred

Use the following procedure when you previously transferred the Slave Terminal setting information to the EtherCAT Slave Terminal. After you complete I/O checking, perform the remaining procedures in *3-2 Procedures* on page 3-7 to commission the EtherCAT Slave Terminal.

### ● When Communications with EtherCAT Master Are Active

- 1** Disconnect the EtherCAT Slave Terminal from the EtherCAT network.  
Refer to the user's manual for the built-in EtherCAT port on the connected CPU Unit or Industrial PC for the procedures to disconnect and connect the EtherCAT Coupler Unit from and to the EtherCAT network.
- 2** Turn OFF the Unit power supply and I/O power supply to the Slave Terminal.
- 3** Disconnect the communications cable from the EtherCAT Coupler Unit.
- 4** Turn ON the Unit power supply and I/O power supply to the Slave Terminal.

## ● When Communications with EtherCAT Master Are Not Active

- 1 Turn OFF the Unit power supply and I/O power supply to the Slave Terminal.
- 2 Disconnect the communications cable from the EtherCAT Coupler Unit.
- 3 Turn ON the Unit power supply and I/O power supply to the Slave Terminal.



### Additional Information

If there is no project on the Sysmac Studio, upload the Slave Terminal setting information from the EtherCAT Slave Terminal to the Sysmac Studio. By doing so, the Unit configuration information on the project agrees with the information in the EtherCAT Coupler Unit, and I/O checking will be possible. Refer to *Uploading Slave Terminal Settings through the USB Port on the EtherCAT Coupler Unit* on page 9-32 for the upload procedure.

## 11-10-4 I/O Checking Operating Procedure

Use the Sysmac Studio to perform I/O checking.

- 1 Connect the Sysmac Studio to the peripheral USB port on the EtherCAT Coupler Unit and place it online.
- 2 Right-click the EtherCAT Coupler Unit in the Edit Slave Terminal Configuration Tab Page, and select **Coupler Connection (USB) – Start I/O Check**.  
The following confirmation dialog box is displayed to confirm starting I/O checking.

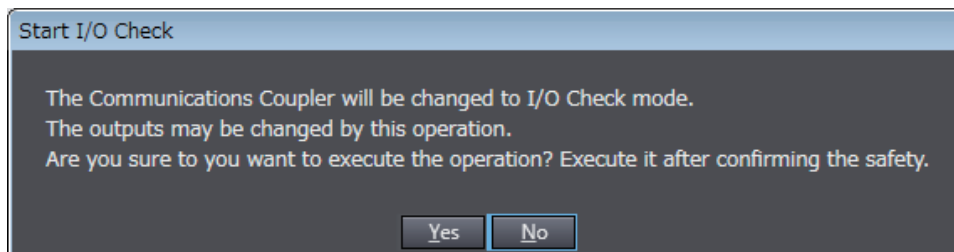

- 3 Click the **Yes** Button.  
The I/O checking function is enabled.  
You cannot perform any other online operations on the Sysmac Studio while the I/O checking function is enabled.
- 4 On the I/O Map Tab Page, monitor the input values or set the output values for the NX Units for which to check the wiring.

Pos	Port	Description	R/W	Data Type	Value	Variable
	▼ EtherCAT Network Con					
	Master					
	▼ NX-ECC201					
	▼ Sysmac Error Status	Sysmac error status	R	BYTE	16#2	
	Observation	Observation	R	BOOL	FALSE	
	Minor Fault	Minor fault	R	BOOL	FALSE	
	Partial Fault	Partial fault	R	BOOL	FALSE	
	Major Fault	Major fault	R	BOOL	FALSE	
	▶ NX Unit Registration	Status whether the N	R	ARRAY[0..15] OF BOOL		
	▶ NX Unit Message En	Status whether com	R	ARRAY[0..15] OF BOOL		
	Ur					
	▼ NX-OD3256					
	Output Bit 00	Output Bit 00	W	BOOL	TRUE	
	Output Bit 01	Output Bit 01	W	BOOL	FALSE	
	Output Bit 02	Output Bit 02	W	BOOL	FALSE	
	Output Bit 03	Output Bit 03	W	BOOL	FALSE	
	Ur					
	▼ NX-OD3256					
	Output Bit 00	Output Bit 00	W	BOOL	FALSE	
	Output Bit 01	Output Bit 01	W	BOOL	FALSE	
	Output Bit 02	Output Bit 02	W	BOOL	FALSE	
	Output Bit 03	Output Bit 03	W	BOOL	FALSE	
	Ur					
	▼ NX-ID3443					
	Input Bit 00	Input Bit 00	R	BOOL	FALSE	
	Input Bit 01	Input Bit 01	R	BOOL	FALSE	
	Input Bit 02	Input Bit 02	R	BOOL	FALSE	
	Input Bit 03	Input Bit 03	R	BOOL	FALSE	
	▼ CPU/Expansion Racks					
	CPU Rack 0					

Monitor type:  Data type  Binary  Hex  Signed decimal  Unsigned decimal

Bit order:  MSB-LSB  LSB-MSB

- 5 After you finish checking the wiring, right-click the EtherCAT Coupler Unit in the Edit Slave Terminal Configuration Tab Page, and select **Coupler Connection (USB) – Stop I/O Check**. The following confirmation dialog box is displayed to confirm ending I/O checking.

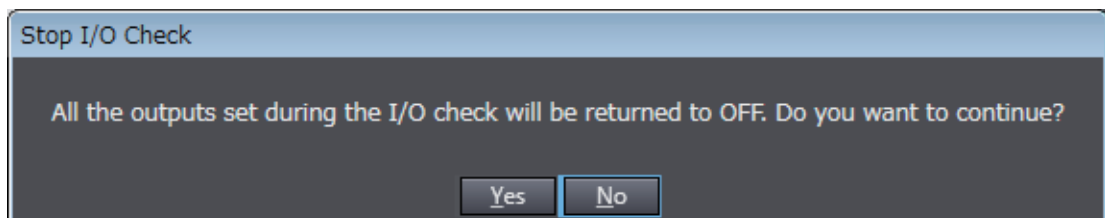

- 6 Click the **Yes** Button.  
When I/O checking is ended, the Slave Terminal is restarted.



#### Precautions for Correct Use

When the Slave Terminal is restarted, all of the Units on the Slave Terminal perform the same operation as when the power supply is cycled. Refer to the manuals for the specific Units for the operation that is performed when the power supply is turned ON.

# 11-11 Fail-soft Operation

This section describes the fail-soft operation for EtherCAT Slave Terminals.

## ✓ Version Information

Fail-soft operation was added for a version upgrade. Refer to *A-11-2 Functions That Were Added or Changed for Each Unit Version* on page A-103 for the unit versions that support fail-soft operation.

### 11-11-1 Overview

This function allows the EtherCAT Coupler Unit to start or continue I/O refreshing only with the NX Units that can operate normally when an error occurs for the EtherCAT Slave Terminal.

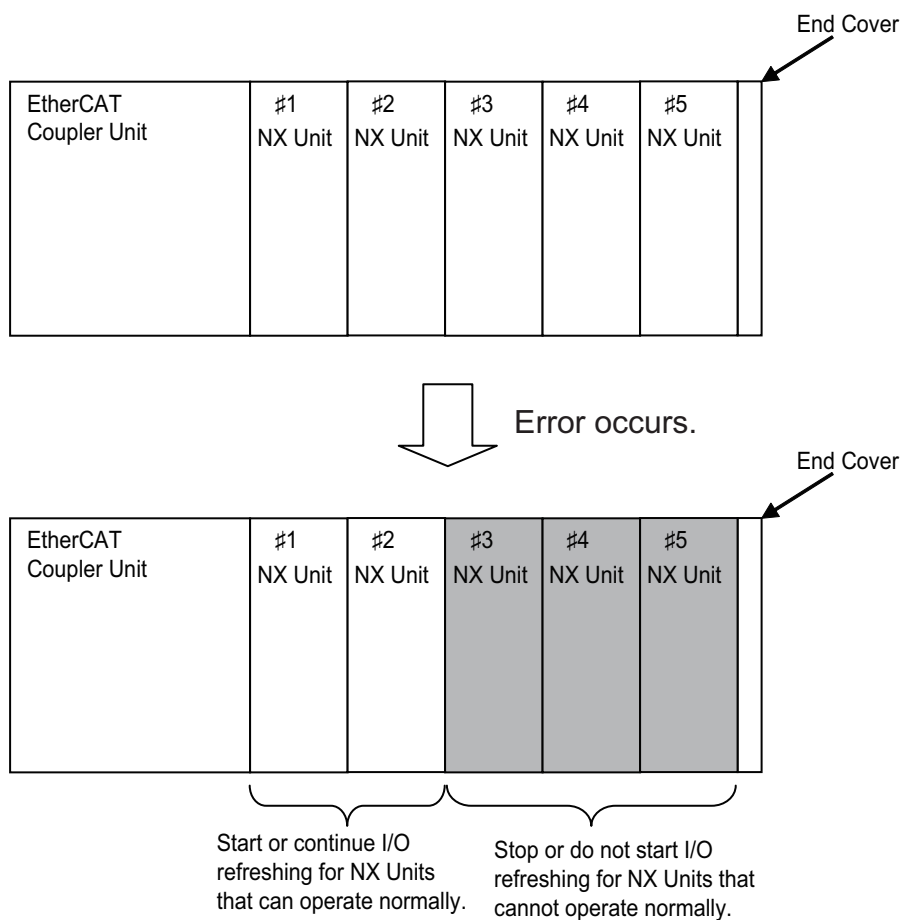



### Precautions for Safe Use

- If you change the fail-soft operation setting, the output status when the error occurs may also change. Confirm safety before you change the setting.
- If you use fail-soft operation, write programming to determine whether Unit I/O data is valid. Without such programming, the user program cannot distinguish between Units for which I/O refreshing is continued and Units for which I/O refreshing is stopped.  
To determine whether Unit I/O data is valid, you must assign the *NX Unit I/O Data Active Status* and the *NX Unit Error Status* from the I/O data that is assignable to the EtherCAT Coupler Unit.  
The *NX Unit Error Status* is not assigned by default. Add it to the I/O entry mapping.  
For sample programming that determines whether the I/O Unit data is valid, refer to *Testing the Validity of I/O Data for Individual Units* on page 9-40 in 9-3-3 *I/O Ports for Status That Accept Device Variable Assignments* on page 9-39.

## 11-11-2 Application

You can use this function in the following cases.

- When it is dangerous to stop the entire EtherCAT Slave Terminal all at once
- To continue the operation of the EtherCAT Slave Terminal until the system can be stopped safely through the user program or user operation
- To not stop all devices, i.e., to continue operation for only some devices

## 11-11-3 Details on Fail-soft Operation

This section describes fail-soft operation in detail.

### Operation for Errors with and without Fail-soft Operation

The following table describes the operation of an EtherCAT Slave Terminal when the EtherCAT Slave Terminal is used with and without fail-soft operation.

Operating status	Operation when an error occurs while starting the EtherCAT Slave Terminal	Operation when an error occurs during normal operation of the EtherCAT Slave Terminal
With fail-soft operation	The EtherCAT Coupler Unit starts I/O refreshing for the NX Units that can operate normally. It does not start I/O refreshing for NX Units that cannot operate normally.	The EtherCAT Coupler Unit continues I/O refreshing for the NX Units that can operate normally. It stops I/O refreshing for NX Units that cannot operate normally.
Without fail-soft operation*1	The EtherCAT Coupler Unit does not start I/O refreshing for any of the NX Units.	The EtherCAT Coupler Unit stops I/O refreshing for all of the NX Units.

\*1. When fail-soft operation is not used, all I/O refreshing is stopped.

Except for the I/O refreshing, the operation when an error occurs for the EtherCAT Slave Terminal is the same regardless of whether fail-soft operation is used. Specifically, error notification is provided and errors are recorded in the event log. Also, the indicators will show the error.

## Setting Fail-soft Operation

### ● Using Fail-soft Operation

To enable fail-soft operation, use the Sysmac Studio to set the *Fail-soft Operation Setting* in the Unit operation settings for the EtherCAT Coupler Unit to *Fail-soft operation*.

After you change the setting, always transfer the Unit operation settings to the EtherCAT Coupler Unit.

For the Unit operation settings of the EtherCAT Coupler Unit and editing procedures, refer to *9-2-5 Unit Operation Settings* on page 9-26. Refer to *9-4 Transferring and Comparing Settings* on page 9-42 for the procedure to transfer the settings.

### ● Not Using Fail-soft Operation

To disable fail-soft operation, use the Sysmac Studio to set the *Fail-soft Operation Setting* in the Unit operation settings for the EtherCAT Coupler Unit to *Stop*. The default setting is *Stop*.

After you change the setting, always transfer the Unit operation settings to the EtherCAT Coupler Unit.

For the Unit operation settings of the EtherCAT Coupler Unit and editing procedures, refer to *9-2-5 Unit Operation Settings* on page 9-26. Refer to *9-4 Transferring and Comparing Settings* on page 9-42 for the procedure to transfer the settings.

## Errors to Which Fail-soft Operation Applies

The following errors are examples of the errors to which fail-soft operation applies.

- Unit Configuration Verification Error\*<sup>1</sup>
- NX Unit Communications Timeout
- NX Unit Initialization Error
- NX Unit Startup Error

\*1. Even if you enable fail-soft operation, the EtherCAT Coupler Unit may not start refreshing I/O for any of the NX Units when the EtherCAT Slave Terminal is started, depending on the cause of the error.

Refer to *Causes of Unit Configuration Verification Errors and Error Operation* on page 11-44 for details on the operation for different error causes.

Refer to *Error Descriptions* on page 13-20 for the errors to which fail-soft operation applies.

If an error occurs to which fail-soft operation does not apply, the EtherCAT Coupler Unit will stop I/O refreshing for all of the NX Units even if you enable *fail-soft operation*.

## Causes of Unit Configuration Verification Errors and Error Operation

Depending on the cause of a Unit Configuration Verification Error, I/O refreshing may not start when the EtherCAT Slave Terminal starts even if *fail-soft operation* is enabled.

Examples are provided below.

Example of Unit configuration information and actual configuration		NX Unit numbers					Description of configuration	Operation when EtherCAT Slave Terminal starts
		1	2	3	4	5		
		Unit configuration information	A	B	C	D		
Actual configuration	Case 1	A	B	C	---	---	Unit D is not mounted.	I/O refreshing is started for NX Unit numbers 1, 2, and 3 because fail-soft operation is enabled.
	Case 2	A	C	D	---	---	Unit B is not mounted.	I/O refreshing does not start for any of the NX Units.
	Case 3	A	B	D	C	---	Units C and D are mounted in reverse order.	I/O refreshing does not start for any of the NX Units.
	Case 4	A	B	C	D	D	An extra Unit D is mounted for NX Unit number 5.	I/O refreshing does not start for any of the NX Units.
	Case 5	A	B	C	F	---	Unit F is mounted for NX Unit number 4, but it does not exist in the Unit configuration information.	I/O refreshing does not start for any of the NX Units.
	Case 6	A	B	C	D	E	Unit E is mounted for NX Unit number 5 even though its NX Unit Mounting Setting is set to <i>Disable</i> .	I/O refreshing does not start for any of the NX Units.

# 11-12 Prohibiting USB Connections

This section describes prohibiting USB connections to an EtherCAT Slave Terminal.



## Version Information

The function for prohibiting USB connections was added for a version upgrade. Refer to *A-11-2 Functions That Were Added or Changed for Each Unit Version* on page A-103 for the unit versions that support prohibiting USB connections.

## 11-12-1 Overview

This function allows you to prohibit a Sysmac Studio online connection through the peripheral USB port on the EtherCAT Coupler Unit.

You can use this function to prevent incorrect machine operation caused by operation mistakes on the Sysmac Studio during machine operation when the Sysmac Studio is connected to the peripheral USB port on an EtherCAT Coupler Unit.

## 11-12-2 Details on Prohibiting USB Connections

This section describes prohibiting USB connections in detail.

### Setting to Prohibit USB Connections

#### ● Enabling Prohibition of USB Connections

To enable prohibiting USB connections, use the Sysmac Studio to set the *Preventing Incorrect Operation/USB Connection Prohibition Setting* in the Unit operation settings for the EtherCAT Coupler Unit to *Enable*.

After you change the setting, always transfer the Unit operation settings to the EtherCAT Coupler Unit.

After you transfer the Unit operation settings with the Sysmac Studio connected to the peripheral USB port on the EtherCAT Coupler Unit, always place the Sysmac Studio offline. If you only transfer the settings, an online connection can be continued.

For the Unit operation settings of the EtherCAT Coupler Unit and editing procedures, refer to *9-2-5 Unit Operation Settings* on page 9-26. Refer to *9-4 Transferring and Comparing Settings* on page 9-42 for the procedure to transfer the settings.

#### ● Disabling Prohibition of USB Connections

To disable prohibiting USB connections, use the Sysmac Studio to set the *Preventing Incorrect Operation/USB Connection Prohibition Setting* in the Unit operation settings for the EtherCAT Coupler Unit to *Disable*. The default setting is *Disable*.

After you change the setting, place the Sysmac Studio online with the EtherCAT Slave Terminal through the NJ/NX-series CPU Unit or NY-series Industrial PC and transfer the Unit operation settings to the EtherCAT Coupler Unit.

For the Unit operation settings of the EtherCAT Coupler Unit and editing procedures, refer to *9-2-5 Unit Operation Settings* on page 9-26. Refer to *9-4 Transferring and Comparing Settings* on page 9-42 for the procedure to transfer the settings.



### Additional Information

---

To transfer the changed Unit operation settings to the EtherCAT Coupler Unit through a connection to the peripheral USB port on the EtherCAT Coupler Unit, disconnect the EtherCAT Slave Terminal from the EtherCAT network first and then transfer the settings.

---

## Situations That Allow Users To Place Sysmac Studio Online Even When Prohibiting USB Connections Is Enabled

---

You can place the Sysmac Studio online in the following situations even when prohibiting USB connections is enabled.

- When an error occurs in the EtherCAT Slave Terminal
- When the communications cable to the EtherCAT Coupler Unit is broken
- When the communications cable is not connected to the EtherCAT Coupler Unit
- When the EtherCAT Slave Terminal is disconnected from the EtherCAT network

Always place the Sysmac Studio offline after these situations are resolved.

If you only resolve the situation, an online connection can be continued.

# 11-13 Monitoring Total Power-ON Time

This section describes how to monitor the total power-ON time for EtherCAT Coupler Units and NX Units.



## Version Information

The function to monitor the total power-ON time was added for a version upgrade. Refer to *A-11-2 Functions That Were Added or Changed for Each Unit Version* on page A-103 for the unit versions that support monitoring the total power-ON time.

## 11-13-1 Overview

Each of the EtherCAT Coupler Units and NX Units records the total time that the Unit power supply is ON to it. You can display these times on the Sysmac Studio.



## Precautions for Correct Use

To record the total power-ON time for any NX Unit that supports this function, you must use an EtherCAT Coupler Unit with a unit version that supports this function.

If you use an EtherCAT Coupler Unit with a unit version that does not support this function, the total power-ON times will not be recorded for the NX Units.

## 11-13-2 Details on Monitoring Total Power-ON Times

The specifications of monitoring the total power-ON times are given in the following table.

Item	Specification
Display unit	<ul style="list-style-type: none"> <li>When total power-ON time is less than 1 hour: Minutes</li> <li>When total power-ON time is 1 hour or longer: Hours</li> </ul>
Update interval	<ul style="list-style-type: none"> <li>When total power-ON time is less than 24 hours: 10 minutes</li> <li>When total power-ON time is 24 hours or longer: 1 hour</li> </ul>
Measurement error	1 hour/month max.
Default setting	0 minutes

## 11-13-3 Checking Total Power-ON Times

You can use the Sysmac Studio to check the total power-ON times of the EtherCAT Coupler Unit and NX Units.

With an NJ-series CPU Unit with version 1.10 or later, an NX-series CPU Unit, or an NY-series Industrial PC, the following instruction can be used to check the total power ON time.

- NX\_ReadTotalPowerOnTime instruction

Refer to the instructions reference manual for the connected CPU Unit or Industrial PC for information on the NX\_ReadTotalPowerOnTime instruction.

On the Sysmac Studio, you can use the **Production Information** to check.

For the procedure to check the **Production Information** on the Sysmac Studio, refer to *Confirming Unit Versions with the Sysmac Studio* on page 36.

- **Display When Times Cannot Be Recorded**

If the total power-ON time cannot be recorded because of a non-volatile memory hardware error, the total power-ON time is displayed as *Invalid record* on the Sysmac Studio.

- **Display for Units That Do Not Support Monitoring the Total Power-ON Time**

If a Unit does not support monitoring the total power-ON time, the total power-ON time for the Unit is displayed as "---" on the Sysmac Studio.

- **Display When Reading the Time Failed**

If reading the time failed, the total power-ON time is displayed as "---" on the Sysmac Studio.



---

**Precautions for Correct Use**

---

To check the total power-ON time for any NX Unit that supports this function, you must use a Sysmac Studio version and an EtherCAT Coupler Unit with a unit version that support this function.

If the unit version of the EtherCAT Coupler Unit or the Sysmac Studio version that you use does not support this function, the total power-ON times will not be recorded for the NX Units.

---

# 12

## Communications Performance

This section describes the I/O response performance of process data communications and the response performance of message communications for EtherCAT Slave Terminals.

---

<b>12-1</b>	<b>Performance of Process Data Communications</b> .....	<b>12-2</b>
12-1-1	I/O Response Times for Synchronous I/O Refreshing .....	12-2
12-1-2	I/O Response Times for Task Period Prioritized Refreshing .....	12-16
12-1-3	I/O Response Times for Time Stamp Refreshing .....	12-23
12-1-4	I/O Response Times for Free-Run Refreshing .....	12-27
<b>12-2</b>	<b>Message Response Time</b> .....	<b>12-36</b>
12-2-1	Special Instructions .....	12-36
12-2-2	Minimum Message Response Time .....	12-36

# 12-1 Performance of Process Data Communications

This section describes the performance of process data communications when an EtherCAT Slave Terminal is connected to the built-in EtherCAT port on an NJ/NX-series CPU Unit or NY-series Industrial PC and I/O refreshing is performed.

The performance of process data communications depends on the I/O refreshing method.

Refer to *Calculating Safety Reaction Times* in the *NX-series Safety Control Unit User's Manual (Cat. No. Z930)* for information on the performance of process data communications when Safety Control Units are connected under the EtherCAT Coupler Unit.



## Precautions for Correct Use

The values found with the calculation formulas for the communications performance are only guidelines. Actual transfer times will vary. Always test performance with the actual equipment before you use the system.

### 12-1-1 I/O Response Times for Synchronous I/O Refreshing

This section describes the I/O response times of NX Units on EtherCAT Slave Terminals under the following conditions.

Item	Condition
CPU Unit or Industrial PC periodic task in which I/O is refreshed	Primary periodic task or priority-5 periodic task*1
I/O refreshing mode	DC Mode
I/O refreshing method for NX Units	Synchronous I/O refreshing

\*1. The connected CPU Unit or Industrial PC must support a priority-5 periodic task. For example, NX701 CPU Units support them. Refer to *Assignment and Settings Related to Tasks* in the software user's manual for the connected CPU Unit or Industrial PC for information on the periodic tasks that are supported by the CPU Unit or Industrial PC.

The I/O response time is the time required for the following processing: The CPU Unit or Industrial PC processes an external signal input to one NX Unit, and another NX Unit outputs the processed result as an external signal.

With synchronous I/O refreshing, when there is more than one EtherCAT Slave Terminal in the same EtherCAT network, the inputs are read or the outputs are updated simultaneously for all of the NX Units that operate with synchronous I/O refreshing on the EtherCAT Slave Terminals for which I/O is refreshed in the same periodic task.

Therefore, when you calculate the I/O response times for an NX Unit on an EtherCAT Slave Terminal, you must use in the calculations the longest elements for the EtherCAT Slave Terminals for which I/O is refreshed in the same periodic task.

Refer to *10-3-4 I/O Refreshing Method Operation* on page 10-10 for details on the operation of synchronous I/O refreshing.

## Prerequisites for Calculations

The calculations that are described in this section assume that the following conditions are met.

- a. Sequence control and motion control in the NJ/NX-series CPU Unit or NY-series Industrial PC are performed within the task period of the periodic task in which EtherCAT communications were refreshed.
- b. The refresh cycle of the NX bus of the EtherCAT Slave Terminal is within the task period of the periodic task.
- c. If you use an NX Unit that has restrictions in the communications cycle in DC Mode, it must be set to a task period for a communications cycle that will satisfy the specifications for the refresh cycles that can be executed by the NX Unit.

You can check for condition (a) by estimating the task execution time. For the checking procedure, refer to the section on *designing tasks* in the software user's manual for the connected CPU Unit or Industrial PC.

You can check for condition (b) from the Sysmac Studio. Refer to *10-3-5 Setting the Task Periods of Periodic Tasks* on page 10-18 for the confirmation procedure.

For condition (c), refer to the appendix of the *NX-series Data Reference Manual (Cat. No. W525)* to see if there are restrictions on any specific NX Units. If there are restrictions, refer to the user's manual for the NX Unit, and confirm that the task period satisfies the specifications for the refresh cycles that can be executed by the NX Unit.

## Timing Chart and Configuration Elements of the I/O Response Time

A timing chart for the I/O response time with synchronous I/O refreshing is provided in the following figure. This timing chart shows the maximum I/O response time.

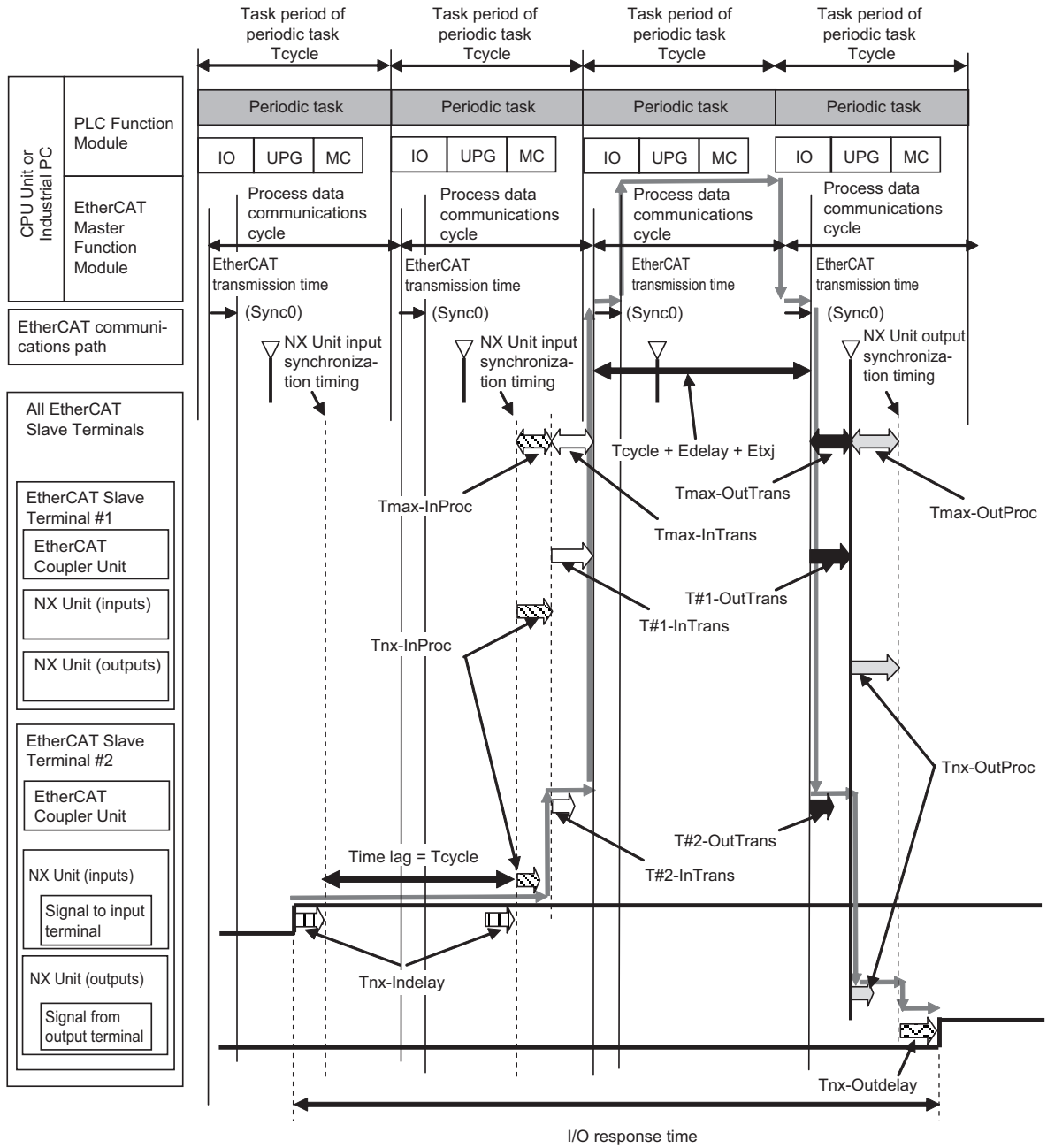

The maximum and minimum values of the I/O response time are calculated as shown below. The minimum value occurs when the time lag that is shown in the above figure does not occur.

Formula: Maximum I/O response time =	$T_{cycle} \times 2 + E_{delay} + E_{txj} + T_{max-InTrans} + T_{max-OutTrans} + T_{max-InProc} + T_{max-OutProc} + T_{nx-Indelay} + T_{nx-Outdelay}$
--------------------------------------	---

Formula: Minimum I/O response time =	$T_{cycle} + E_{delay} + E_{txj} + T_{max-InTrans} + T_{max-OutTrans} + T_{max-InProc} + T_{max-OutProc} + T_{nx-Indelay} + T_{nx-Outdelay}$
--------------------------------------	--

If you perform I/O refreshing for EtherCAT Slave Terminals at a built-in EtherCAT port that supports process data communications with a Slave Terminal in more than one periodic task, calculate the I/O response times for each EtherCAT Slave Terminal for the task period of each periodic task of the CPU Unit that performs the I/O refreshing.

The elements in the formulas are as follows:

- Tcycle: Task period of the periodic task in the CPU Unit or Industrial PC
- Edelay: Transmission delay time of the EtherCAT master
- Etxj: Transmission jitter of the EtherCAT master
- Tmax-InTrans: Longest input data transmission time of all of the EtherCAT Coupler Units.
- Tmax-OutTrans: Longest output data transmission time of all of the EtherCAT Coupler Units.
- Tmax-InProc: Longest input data processing time of all of the NX Units.
- Tmax-OutProc: Longest output data processing time of all of the NX Units.
- Tnx-Indelay: Input delay time of the NX Unit
- Tnx-Outdelay: Output delay time of the NX Unit

## Definitions of Formula Elements and Calculation Methods

This section defines the calculation formula elements and describes the calculation methods.

### ● Tcycle

This is the time that is set for the task period of the periodic task in the CPU Unit or Industrial PC.

### ● Edelay

This is the transmission delay time of the EtherCAT master. The calculation method of Edelay depends on the type of the CPU Unit or Industrial PC and the periodic task in the CPU Unit or the Industrial PC that performs I/O refreshing. These are given in the following table.

Type of CPU Unit or Industrial PC*1	CPU Unit or Industrial PC periodic task in which I/O is refreshed	Calculation method
NX-series NX701 CPU Unit	Primary periodic task	<ul style="list-style-type: none"> <li>• Calculate with the Sysmac Studio.</li> <li>• Calculate with a formula.</li> </ul>
	Priority-5 periodic task	Calculate with the Sysmac Studio.
NX-series NX1P2 CPU Unit	Primary periodic task	<ul style="list-style-type: none"> <li>• Calculate with the Sysmac Studio.</li> <li>• Calculate with a formula.</li> </ul>
NJ-series CPU Unit		Calculate with a formula.
NY-series Industrial PC		<ul style="list-style-type: none"> <li>• Calculate with the Sysmac Studio.</li> <li>• Calculate with a formula.</li> </ul>
		Calculate with a formula.

\*1. If you connect the Slave Terminal to a CPU Unit or Industrial PC whose model is not given in the table, refer to *Transmission Delay Time in System Response Time in Process Data Communications* in the user's manual for the built-in EtherCAT port on the connected CPU Unit or Industrial PC for information on the calculation method.

Details on the calculation methods are given below.

#### a. Calculation with the Sysmac Studio

You can display the transmission delay times of the EtherCAT master with the Sysmac Studio. Refer to *Displaying the Transmission Delay Times of the EtherCAT Master* on page 9-34 in *9-2-7 Sysmac Studio Functions Used as Required* on page 9-28 for details on the calculation methods.

#### b. Calculation with a Formula

The formula depends on the model or unit version of the connected CPU Unit or Industrial PC. Refer to *Transmission Delay Time in System Response Time in Process Data Communications* in the user's manual for the built-in EtherCAT port on the connected CPU Unit or Industrial PC for details on the formula for the CPU Unit or Industrial PC.

For example, when an NJ/NX-series CPU Unit with project unit version earlier than 1.40 in the Sysmac Studio project is connected, use the following formula to calculate Edelay.

The value that is found in the formula is a roughly-estimated value.

Formula: $Edelay = 1.24 [\mu s] \times \text{Number of EtherCAT slaves}$ $+ 0.082 [\mu s] \times \text{EtherCAT frame length in bytes}$ $+ 0.01 [\mu s] \times \text{Total cable length (m)}$
---

The parameters required for the calculation are described in the following table.

Parameter	Meaning
Number of EtherCAT Slaves	This is the number of all of the EtherCAT slaves in the same EtherCAT network. An EtherCAT Slave Terminal is counted as one EtherCAT slave.
EtherCAT Frame Length in Bytes	<p>The EtherCAT frame length is the data byte size that is calculated under the following conditions for the EtherCAT slaves in the same EtherCAT network and for which I/O is refreshed in the primary periodic task.</p> <ul style="list-style-type: none"> <li>• If the total data size is less than 64 bytes, use 64 bytes in the calculation.</li> <li>• For EtherCAT slaves that have both input and output data, use the larger of the input data size and output data size.</li> </ul> <p>For example, the EtherCAT frame length in bytes for the following configuration is as given below.  <i>EtherCAT frame length</i> = 20 bytes + 20 bytes + 50 bytes = 90 bytes            Configuration Example</p> <ul style="list-style-type: none"> <li>• Two OMRON GX-series EtherCAT slaves: Data size of 20 bytes/slave</li> <li>• One EtherCAT Slave Terminal: Input data size of 50 bytes and output data size of 30 bytes</li> </ul>
Total Cable Length (m)	This is the total cable length, including the cable between the master and a slave and cables between slaves.

## ● Etxj

This is the transmission jitter of the EtherCAT master.

The following table gives the value of Etxj for the different types of CPU Units and Industrial PCs.

Type of CPU Unit or Industrial PC*1	Etxj
NX-series NX701 CPU Unit	10 [ $\mu$ s]
NX-series NX1P2 CPU Unit	10 [ $\mu$ s]
NY-series Industrial PC	10 [ $\mu$ s]
NJ-series CPU Unit	100 [ $\mu$ s]

\*1. If you connect the Slave Terminal to a CPU Unit or Industrial PC whose model is not given in the table, refer to *Transmission Jitter in System Response Time in Process Data Communications* in the user's manual for the built-in EtherCAT port on the connected CPU Unit or Industrial PC to check Etxj values.

## ● Tmax-InTrans

This is the longest input transmission time of the EtherCAT Coupler Units in the EtherCAT Slave Terminals in the same EtherCAT network and for which I/O is refreshed in the same periodic task. The input data transmission time is the time that is required for the EtherCAT Coupler Unit to read all of the input data for all of the NX Units. After all of the input data is read, the EtherCAT Coupler Unit is ready to send the data to the EtherCAT communications path.

Use the following formula to find Tmax-InTrans.

Formula:  $T_{\max\text{-InTrans}} = \text{Max}(T_{\#1\text{-InTrans}}, T_{\#2\text{-InTrans}}, \dots, T_{\#n\text{-InTrans}})$   
 "Max" indicates the maximum value in the parentheses.

- \*1.  $T_{\#1\text{-InTrans}}$  is the input data transmission time of the EtherCAT Coupler Unit in the EtherCAT Slave Terminal with node address 1.
- \*2.  $T_{\#2\text{-InTrans}}$  is the input data transmission time of the EtherCAT Coupler Unit in the EtherCAT Slave Terminal with node address 2.
- \*3.  $T_{\#n\text{-InTrans}}$  is the input data transmission time of the EtherCAT Coupler Unit in the EtherCAT Slave Terminal with node address n. "#n" indicates the node address of the EtherCAT Slave Terminal. "n" is the address.

The formula to calculate  $T_{\#n\text{-InTrans}}$  depends on the model of the EtherCAT Coupler Unit. Use the calculation formula for the EtherCAT Coupler Unit that you will use.

### a. NX-ECC203

Use the following formula.

Formula:  $T_{\#n\text{-InTrans}} = 5.92 \times (\text{Integer quotient of total byte size}^{*1} \text{ of the NX Unit input data} \div 32)^2 + 0.19 \times (\text{Remainder of quotient of total byte size}^{*1} \text{ of the NX Unit input data} \div 32)^3 + (0.36 \times \text{Number of NX Units with BOOL input data}^{*4} + 1.19)^5 + 2.15 \times \text{Number of NX Units}^{*6} + 0.15 \times \text{Total byte size of NX Unit input data}^{*1} + 35.85$   
 (Unit:  $\mu\text{s}$ )

- \*1. This is the total byte size of the input data of all of the NX Units in the EtherCAT Slave Terminal.
  - \*2. Round down the value that results from the calculation in parentheses to an integer. It is expressed as follows with a Microsoft Excel function:  
 $\text{ROUNDDOWN}(\text{Total\_byte\_size\_of\_all\_NX\_Unit\_input\_data}/32,0)$
  - \*3. This is the remainder. It is expressed as follows with a Microsoft Excel function:  
 $\text{MOD}(\text{Total\_byte\_size\_of\_all\_NX\_Unit\_input\_data}/32,0)$
  - \*4. This is the number of all of the NX Units for which there are I/O assignments to BOOL input data in the EtherCAT Slave Terminal. For example, the NX-ID3317 meets this condition because it is an NX Unit that has BOOL input data. However, the NX-ID4342 does not meet this condition because it is an NX Unit that has BYTE input data.
  - \*5. If there are no NX Units in the EtherCAT Slave Terminal that have I/O assignments to BOOL input data, use 0 for the calculation in parentheses.
  - \*6. This is the total number of all of the NX Units in the EtherCAT Slave Terminal.
- ### b. NX-ECC201 or NX-ECC202
- Use the following formula.

Formula: T#n-InTrans =	$  \begin{aligned}  &9.22 \times (\text{Integer quotient of } \textit{total byte size}^{*1} \textit{ of the NX Unit input data} \div 32)^2 \\  &+ 0.55 \times (\text{Remainder of } \textit{quotient of total byte size}^{*1} \textit{ of the NX Unit input data} \div \\  &32)^3 \\  &+ (0.34 \times \textit{Number of NX Units with BOOL input data}^{*4} + 3.41)^{*5} \\  &+ 3.53 \times \textit{Number of NX Units}^{*6} \\  &+ 0.014 \times \textit{Total byte size of NX Unit input data}^{*1} \\  &+ 75.17  \end{aligned}  $	(Unit: $\mu\text{s}$ )
---------------------------	---	------------------------

- \*1. This is the total byte size of the input data of all of the NX Units in the EtherCAT Slave Terminal.
- \*2. Round down the value that results from the calculation in parentheses to an integer. It is expressed as follows with a Microsoft Excel function:  
`ROUNDDOWN(Total_byte_size_of_all_NX_Unit_input_data/32,0)`
- \*3. This is the remainder. It is expressed as follows with a Microsoft Excel function:  
`MOD(Total_byte_size_of_all_NX_Unit_input_data/32,0)`
- \*4. This is the number of all of the NX Units for which there are I/O assignments to BOOL input data in the EtherCAT Slave Terminal. For example, the NX-ID3317 meets this condition because it is an NX Unit that has BOOL input data. However, the NX-ID4342 does not meet this condition because it is an NX Unit that has BYTE input data.
- \*5. If there are no NX Units in the EtherCAT Slave Terminal that have I/O assignments to BOOL input data, use 0 for the calculation in parentheses.
- \*6. This is the total number of all of the NX Units in the EtherCAT Slave Terminal.

## ● Tmax-OutTrans

This is the longest output transmission time of the EtherCAT Coupler Units in the EtherCAT Slave Terminals in the same EtherCAT network and for which I/O is refreshed in the same periodic task. The output data transmission time is the time that is required for the EtherCAT Coupler Unit to read the output data from the EtherCAT communications path and send the data to the NX Units. With synchronous I/O refreshing or task period prioritized refreshing, the data transmission is completed before the Sync0 timing.

Use the following formula to find Tmax-OutTrans.

Formula: Tmax-OutTrans = Max(T#1-OutTrans, <sup>*1</sup> T#2-OutTrans, <sup>*2</sup> ...T#n-OutTrans <sup>*3</sup> "Max" indicates the maximum value in the parentheses.
---

- \*1. T#1-OutTrans is the output data transmission time of the EtherCAT Coupler Unit in the EtherCAT Slave Terminal with node address 1.
- \*2. T#2-OutTrans is the output data transmission time of the EtherCAT Coupler Unit in the EtherCAT Slave Terminal with node address 2.
- \*3. T#n-OutTrans is the output data transmission time of the EtherCAT Coupler Unit in the EtherCAT Slave Terminal with node address n. "#n" indicates the node address of the EtherCAT Slave Terminal. "n" is the address.

The formula to calculate T#n-OutTrans depends on the model of the EtherCAT Coupler Unit. Use the calculation formula for the EtherCAT Coupler Unit that you will use.

- a. NX-ECC203  
 Use the following formula.

$$\begin{aligned}
 \text{Formula: } T\#n\text{-OutTrans} = & 6.08 \times (\text{Integer quotient of } total\ byte\ size^{*1}\ \text{of the NX Unit output data} \div 32)^2 \\
 & + 0.19 \times (\text{Remainder of quotient of } total\ byte\ size^{*1}\ \text{of the NX Unit output data} \div 32)^3 \\
 & + (0.31 \times \text{Number of NX Units with BOOL output data}^{*4} + 1.22)^{*5} \\
 & + (3.31 \times \text{Number of NX Units with output refreshing with specific time stamps}^{*6} + 2.80)^{*7} \\
 & + 0.38 \times \text{Number of NX Units}^{*8} \\
 & + 0.15 \times \text{Total byte size of NX Unit output data}^{*1} \\
 & + 17.76
 \end{aligned}$$

(Unit:  $\mu$ s)

- \*1. This is the total byte size of the output data of all of the NX Units in the EtherCAT Slave Terminal.
- \*2. Round down the value that results from the calculation in parentheses to an integer. It is expressed as follows with a Microsoft Excel function:  
`ROUNDDOWN(Total_byte_size_of_all_NX_Unit_output_data/32,0)`
- \*3. This is the remainder. It is expressed as follows with a Microsoft Excel function:  
`MOD(Total_byte_size_of_all_NX_Unit_output_data/32,0)`
- \*4. This is the number of all of the NX Units for which there are I/O assignments to BOOL output data in the EtherCAT Slave Terminal. For example, the NX-OD3121 meets this condition because it is an NX Unit that has BOOL output data. However, the NX-OD4121 does not meet this condition because it is an NX Unit that has BYTE output data.
- \*5. If there are no NX Units in the EtherCAT Slave Terminal that have I/O assignments to BOOL output data, use 0 for the calculation in parentheses.
- \*6. This is the total number of NX Units that support output refreshing with specified time stamps with the following model numbers in the EtherCAT Slave Terminal.  
 NX-OD2154 or NX-OD2258
- \*7. If there are no NX Units that support output refreshing with specified time stamps with the following model numbers in the EtherCAT Slave Terminal, use a value of 0.  
 NX-OD2154 or NX-OD2258
- \*8. This is the total number of all of the NX Units in the EtherCAT Slave Terminal.

b. NX-ECC201 or NX-ECC202

Use the following formula.

$$\begin{aligned}
 \text{Formula: } T\#n\text{-OutTrans} = & 11.71 \times (\text{Integer quotient of } total\ byte\ size^{*1}\ \text{of the NX Unit output data} \div 32)^2 \\
 & + 0.46 \times (\text{Remainder of quotient of } total\ byte\ size^{*1}\ \text{of the NX Unit output data} \div 32)^3 \\
 & + (0.19 \times \text{Number of NX Units with BOOL output data}^{*4} + 2.93)^{*5} \\
 & + (8.10 \times \text{Number of NX Units with output refreshing with specified time stamps}^{*6} + 4.49)^{*7} \\
 & + 0.38 \times \text{Number of NX Units}^{*8} \\
 & + 0.014 \times \text{Total byte size of NX Unit output data}^{*1} \\
 & + 30.40
 \end{aligned}$$

(Unit:  $\mu$ s)

- \*1. This is the total byte size of the output data of all of the NX Units in the EtherCAT Slave Terminal.
- \*2. Round down the value that results from the calculation in parentheses to an integer. It is expressed as follows with a Microsoft Excel function:  
`ROUNDDOWN(Total_byte_size_of_all_NX_Unit_output_data/32,0)`
- \*3. This is the remainder. It is expressed as follows with a Microsoft Excel function:  
`MOD(Total_byte_size_of_all_NX_Unit_output_data/32,0)`

- \*4. This is the number of all of the NX Units for which there are I/O assignments to BOOL output data in the EtherCAT Slave Terminal. For example, the NX-OD3121 meets this condition because it is an NX Unit that has BOOL output data. However, the NX-OD4121 does not meet this condition because it is an NX Unit that has BYTE output data.
- \*5. If there are no NX Units in the EtherCAT Slave Terminal that have I/O assignments to BOOL output data, use 0 for the calculation in parentheses.
- \*6. This is the total number of NX Units that support output refreshing with specified time stamps with the following model numbers in the EtherCAT Slave Terminal.  
NX-OD2154 or NX-OD2258
- \*7. If there are no NX Units that support output refreshing with specified time stamps with the following model numbers in the EtherCAT Slave Terminal, use a value of 0.  
NX-OD2154 or NX-OD2258
- \*8. This is the total number of all of the NX Units in the EtherCAT Slave Terminal.

### ● Tmax-InProc

This is the longest time in the NX Unit input processing times (Tnx-InProc) in the EtherCAT Slave Terminals in the same EtherCAT network and for which I/O is refreshed in the same periodic task. This is the longest time of the NX Units that operate with the following I/O refresh methods in the calculations of the I/O response times for synchronous I/O refreshing.

- Synchronous I/O refreshing
- Input refreshing with input changed time for time stamp refreshing

Calculations of NX Units that operate with Free-Run refreshing or task period prioritized refreshing are not included.

The input data processing time of an NX Unit (Tnx-InProc) is the time from reading the status of the NX Unit input terminals into memory until preparations to pass the read data to the EtherCAT Coupler Unit are completed. There is a unique value for each type of NX Unit. With synchronous I/O refreshing, this is the time from the NX Unit input synchronization timing until preparations to pass the data to the EtherCAT Coupler Unit are completed. The NX Unit input synchronization timing is when all NX Units with synchronous input refreshing simultaneously read the inputs and all NX Units with input refreshing with input changed times simultaneously read the input changed times in the EtherCAT Slave Terminals in the same EtherCAT network and for which I/O is refreshed in the same periodic task.

The NX Unit input data processing time (Tnx-InProc) depends on the NX Unit. Refer to the appendix of the *NX-series Data Reference Manual (Cat. No. W525)* for the values of Tnx-InProc for NX Units that operate with synchronous I/O refreshing or with input refreshing with input changed time for time stamp refreshing.

### ● Tmax-OutProc

This is the longest time in the NX Unit output processing times (Tnx-OutProc) in the EtherCAT Slave Terminals in the same EtherCAT network and for which I/O is refreshed in the same periodic task. This is the longest time of the NX Units that operate with synchronous I/O refreshing in the calculations of the I/O response times for synchronous I/O refreshing. Calculations of NX Units that operate with Free-Run refreshing, task period prioritized refreshing, or time stamp refreshing are not included.

The output data processing time of an NX Unit (Tnx-OutProc) is the time from when the NX Unit reads the output data that was sent by the EtherCAT Coupler Unit until preparations to update the

output data are completed. There is a unique value for each type of NX Unit. With synchronous I/O refreshing, each NX Unit completes processing before the NX Unit output synchronization timing. The NX Unit output synchronization timing is when all of the NX Units that use synchronous output refreshing in the EtherCAT Slave Terminals in the same EtherCAT network and for which I/O is refreshed in the same periodic task simultaneously update the output data.

The NX Unit output data processing time (Tnx-OutProc) depends on the NX Unit. Refer to the appendix of the *NX-series Data Reference Manual (Cat. No. W525)* for the values of Tnx-OutProc for NX Units that operate with synchronous I/O refreshing.

### ● Tnx-Indelay

This is the input delay time of the NX Unit. It is the time required for the NX Unit to read the status of the input terminals into NX Unit memory. There is a unique value for each type of NX Unit. The NX Unit input delay time depends on the NX Unit. Refer to the appendix of the *NX-series Data Reference Manual (Cat. No. W525)* for the values of Tnx-Indelay for NX Units that operate with synchronous I/O refreshing.

### ● Tnx-Outdelay

This is the output delay time of the NX Unit. This is the time to change the output terminals according to the updated output data in the NX Unit. There is a unique value for each type of NX Unit. The NX Unit output delay time depends on the NX Unit. Refer to the appendix of the *NX-series Data Reference Manual (Cat. No. W525)* for the values of Tnx-Outdelay for NX Units that operate with synchronous I/O refreshing.

## Calculation Precautions

Observe the following precautions when you make the calculations.

- If you perform I/O refreshing for EtherCAT Slave Terminals at a built-in EtherCAT port that supports process data communications with a Slave Terminal in more than one periodic task, calculate the I/O response times for each EtherCAT Slave Terminal for the task period of each periodic task of the CPU Unit that performs the I/O refreshing.
- Include the NX Units that are set to *Disable* in the NX Unit Mounting Setting.
- Even if you disabled a channel when you select the channels to use for an Analog I/O Unit, use the data size for when all channels are enabled to calculate the elements.
- Use bytes as the unit for NX Units that have a data byte size of less than one byte.  
For example, the byte size is as follows for an NX Unit with a data size of 4 bits.  
 $4 \text{ (bits)} \div 8 \text{ (bits/byte)} = 0.5 \text{ (bytes)}$
- Use the data sizes that you will actually use in the data size calculations.

Refer to this manual, the user's manuals for individual NX Units, or to the *NX-series Data Reference Manual (Cat. No. W525)* for the default values of the Unit data sizes.

## Calculation Example

This section provides a calculation example for I/O response times.

## ● Calculation Conditions

Calculations are made for the following conditions.

### a. Configuration

The following configuration is used. In this example, an NJ-series CPU Unit with project unit version earlier than 1.40 in the Sysmac Studio project is used to refresh I/O with an EtherCAT Slave Terminal. The total cable length is 50 m.

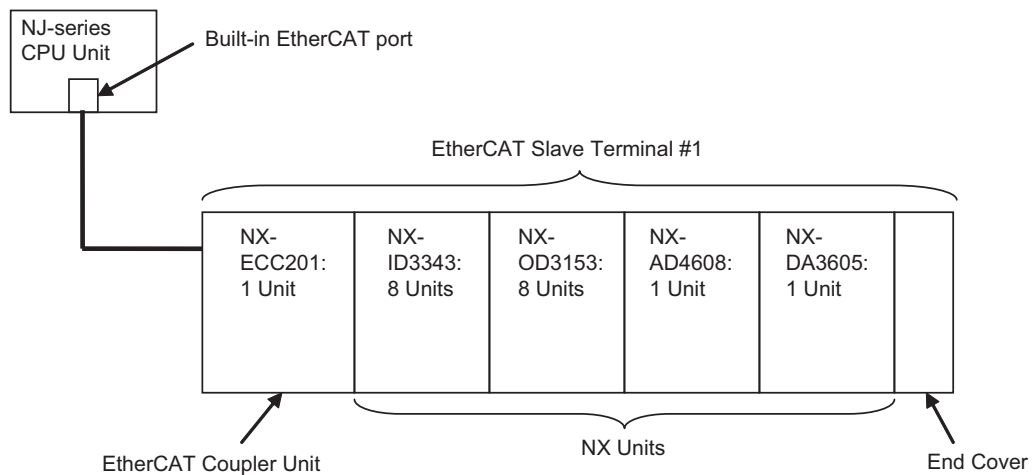

- b. With the above configuration, the I/O response time is calculated as the time from when the CPU Unit processes an external input signal to the NX-ID3343 until the signal is output from the NX-OD3153.
- c. It is assumed that  $T_{cycle}$  is set to 500  $\mu$ s.
- d. The default I/O allocations settings are used for the EtherCAT Slave Terminal.
- e. The input filter time for the NX-ID3343 is set to *No filter*.
- f. The power supply design conditions are not considered in this calculation example.

## ● Unit Configuration and Data Sizes in the EtherCAT Slave Terminal

The unit configuration and data sizes in the EtherCAT Slave Terminal are given in the following table.

Unit type	Model number	Number of Units	Byte size of input data	Byte size of output data	No. of NX Units with BOOL input data	No. of NX Units with BOOL output data
EtherCAT Coupler Unit	NX-ECC201	1	34	0	---	---
Digital Input Units	NX-ID3343	8	4*1	0	8	---
Digital Output Units	NX-OD3153	8	0	4*2	---	8
Analog Input Units	NX-AD4608	1	16	0	0*3	---
Analog Output Units	NX-DA3605	1	0	8	---	0*4
Total for EtherCAT Slave Terminal		19	54	12	---	---
Total for NX Units		18	20	12	8	8

\*1. The input data size of one NX-ID3343 is 0.5 bytes. Therefore, the byte size of the input data is 8 Units  $\times$  0.5 bytes, or 4 bytes.

- \*2. The output data size of one NX-OD3153 is 0.5 bytes. Therefore, the byte size of the input data is 8 Units  $\times$  0.5 bytes, or 4 bytes.
- \*3. This Unit has INT data, so there are 0 Units.
- \*4. This Unit has INT data, so there are 0 Units.

There are no NX-OD2154 or NX-OD2258 Units, which support output refreshing with specified time stamps, in the configuration example.

## ● Calculating the Elements of the I/O Response Times

This section shows how to calculate the elements of the I/O response times.

### a. Calculating Edelay

The following parameters are required to calculate the value.

Parameter	Value	Remarks
Number of EtherCAT slaves	1*1	An EtherCAT Slave Terminal is counted as one EtherCAT slave.
EtherCAT frame length in bytes	64 bytes*1	The EtherCAT Slave Terminal has a total input data size of 54 bytes and a total output data size of 12 bytes. Both the input data size and output data size are less than 64 bytes, so 64 bytes is used.
Total Cable Length (m)	50 m	The value is for this configuration example.

\*1. Refer to *Unit Configuration and Data Sizes in the EtherCAT Slave Terminal* on page 12-12 for the parameter values.

Therefore, the value of Edelay is as follows:

Formula:	=	$1.24 \times \text{Number of EtherCAT slaves}$
Edelay	+	$0.082 \times \text{EtherCAT frame length in bytes}$
	+	$0.01 \times \text{Total cable length (m)}$
	=	$1.24 \times 1 \text{ unit} + 0.082 \times 64 \text{ bytes} + 0.01 \times 50 \text{ m}$
	=	6.988
	≈	7
		(Unit: $\mu\text{s}$ )

### b. Calculating Etxj

The value of Etxj is fixed. The value is given below.

Formula: Etxj = 100	(Unit: $\mu\text{s}$ )
---------------------	------------------------

### c. Calculating Tmax-InTrans

There is only one EtherCAT Slave Terminal, so the value is as follows:

$$T_{\text{max-InTrans}} = T_{\#1\text{-InTrans}}$$

The following parameters are required to calculate T#1-InTrans.

Parameter	Value	Remarks
Total byte size of the input data of the NX Unit	20 bytes	This is the total input data size of the NX Unit.
Number of NX Units	18 Units	---
Number of NX Units with BOOL input data	8 Units	---

Refer to *Unit Configuration and Data Sizes in the EtherCAT Slave Terminal* on page 12-12 for the values of the above parameters.

Therefore, the value of Tmax-InTrans is as follows:

Formula: Tmax-In-Trans	=	T#1-InTrans
	=	9.22 × (Integer quotient of <i>total byte size of the input data of the NX Unit</i> ÷ 32)
		+ 0.55 × (Remainder of <i>total byte size of the input data of the NX Unit</i> ÷ 32)
		+ (0.34 × <i>Number of NX Units with BOOL input data</i> + 3.41)
		+ 3.53 × <i>Number of NX Units</i>
		+ 0.014 × <i>Total byte size of NX Unit input data</i>
		+ 75.17
	=	9.22 × (Integer quotient of 20 bytes ÷ 32)
		+ 0.55 × (Remainder of 20 bytes ÷ 32)
		+ (0.34 × 8 Units + 3.41) + 3.53 × 18 Units
		+ 0.014 × 20 bytes + 75.17
	=	9.22 × 0.00 + 0.55 × 20.00 + (0.34 × 8 Units + 3.41)
		+ 3.53 × 18 Units + 0.014 × 20 bytes + 75.17
	=	156.12

(Unit: μs)

d. Calculating Tmax-OutTrans

There is only one EtherCAT Slave Terminal, so the value is as follows:

$$T_{\max}\text{-OutTrans} = T\#1\text{-OutTrans}$$

The following parameters are required to calculate T#1-OutTrans.

Parameter	Value	Remarks
Total byte size of the output data of the NX Unit	12 bytes	This is the total output data size of the NX Unit.
Number of NX Units	18 Units	---
Number of NX Units with BOOL output data	8 Units	---

Refer to *Unit Configuration and Data Sizes in the EtherCAT Slave Terminal* on page 12-12 for the values of the above parameters.

Therefore, the value of Tmax-OutTrans is as follows:

Formula: Tmax-Out-Trans	=	T#1-OutTrans
	=	11.71 × (Integer quotient of <i>total byte size of the output data of the NX Unit</i> ÷ 32) + 0.46 × (Remainder of <i>total byte size of the output data of the NX Unit</i> ÷ 32)
		+ (0.19 × <i>Number of NX Units with BOOL output data</i> + 2.93)
		+ (8.10 × <i>Number of NX Units with output refreshing with specified time stamps</i> + 4.49) + 0.38 × <i>Number of NX Units</i> + 0.014 × <i>Total byte size of NX Unit output data</i> + 30.40
	=	11.71 × (Integer quotient of 12 bytes ÷ 32) + 0.46 × (Remainder of 12 bytes ÷ 32) + (0.19 × 8 Units + 2.93) + 0 + 0.38 × 18 Units + 0.014 × 12 bytes + 30.40
	=	11.71 × 0.00 + 0.46 × 12.00 + (0.19 × 8 Units + 2.93) + 0 + 0.38 × 18 Units + 0.014 × 12 bytes + 30.40
	=	47.38

(Unit: μs)

## e. Calculating Tmax-InProc

Tnx-InProc for an NX-ID3343 Digital Input Unit and an NX-AD4608 Analog Input Unit is 0 μs. Therefore, the value of Tmax-InProc is as follows:

Formula: Tmax-InProc = 0.00
-----------------------------

(Unit: μs)

## f. Calculating Tmax-OutProc

Tnx-OutProc of an NX-OD3153 Digital Output Unit is 0 μs.

Tnx-OutProc of an NX-DA3605 Analog Output Unit is defined as the *conversion time times the number of points*. The conversion time is 10 μs per point and there are 4 points.

Therefore, the value of Tmax-OutProc is as follows:

Formula: Tmax-OutProc = <i>Conversion time</i> × <i>Number of points</i> = 10 × 4 points = 40.00
--

(Unit: μs)

## g. Calculating Tnx-Indelay

Tnx-Indelay of an NX-ID3343 Digital Input Unit is defined as the *ON/OFF response time plus the input filter time*. The ON/OFF response time is 0.10 μs and the input filter time is 0 μs.\*1

\*1. Calculation condition (e) says there is *no filter*, so the time is 0 μs.

Therefore the value of Tnx-Indelay for the NX-ID3343 Digital Input Unit is as follows:

Formula: Tnx-Indelay = 0.10
-----------------------------

(Unit: μs)

## h. Calculating Tnx-Outdelay

The Tnx-Outdelay of an NX-OD3153 Digital Output Unit is defined as the *ON/OFF response time*. The ON/OFF response time is 0.30 μs.

Therefore the value of Tnx-Outdelay for the NX-OD3153 Digital Output Unit is as follows:

Formula: Tnx-Outdelay = 0.30
------------------------------

(Unit: μs)

## ● Calculating the I/O Response Times

The I/O response times are as follows based on the calculation results for the elements.

Formula: Maximum I/O response time	=	$T_{\text{cycle}} \times 2 + E_{\text{delay}} + E_{\text{txj}} + T_{\text{max-InTrans}} + T_{\text{max-OutTrans}} + T_{\text{max-InProc}} + T_{\text{max-OutProc}} + T_{\text{nx-InDelay}} + T_{\text{nx-OutDelay}}$
	=	$500 \times 2 + 7 + 100 + 156.12 + 47.38 + 0.00 + 40.00 + 0.10 + 0.30$
	=	1350.90

(Unit:  $\mu\text{s}$ )

Formula: Minimum I/O response time	=	$T_{\text{cycle}} + E_{\text{delay}} + E_{\text{txj}} + T_{\text{max-InTrans}} + T_{\text{max-OutTrans}} + T_{\text{max-InProc}} + T_{\text{max-OutProc}} + T_{\text{nx-InDelay}} + T_{\text{nx-OutDelay}}$
	=	$500 + 7 + 100 + 156.12 + 47.38 + 0.00 + 40.00 + 0.10 + 0.30$
	=	850.90

(Unit:  $\mu\text{s}$ )

## 12-1-2 I/O Response Times for Task Period Prioritized Refreshing

This section describes the I/O response times of NX Units on EtherCAT Slave Terminals under the following conditions.

Item	Condition
CPU Unit or Industrial PC periodic task in which I/O is refreshed	Primary periodic task or priority-5 periodic task* <sup>1</sup>
I/O refreshing mode	DC Mode
I/O refreshing method for NX Units	Task period prioritized refreshing

\*1. The connected CPU Unit or Industrial PC must support a priority-5 periodic task. For example, NX701 CPU Units support them. Refer to *Assignment and Settings Related to Tasks* in the software user's manual for the connected CPU Unit or Industrial PC for information on the periodic tasks that are supported by the CPU Unit or Industrial PC.

The I/O response time is the time required for the following processing: The CPU Unit or Industrial PC processes an external signal input to one NX Unit, and another NX Unit outputs the processed result as an external signal.

With task period prioritized refreshing, shortening the task period is given priority over synchronizing the I/O timing with other NX Units. With this I/O refreshing method, the timing of I/O is not consistent with the timing of I/O for NX Units that use synchronous I/O refreshing.

Refer to *10-3-4 I/O Refreshing Method Operation* on page 10-10 for details on the operation of task period prioritized refreshing.

### Prerequisites for Calculations

These are the same as the prerequisites for calculating the I/O response time for synchronous I/O refreshing.

Refer to *Prerequisites for Calculations* on page 12-3 in *12-1-1 I/O Response Times for Synchronous I/O Refreshing* on page 12-2 for the prerequisites for calculations.

### Timing Chart and Configuration Elements of the I/O Response Time

A timing chart for the maximum I/O response time with task period prioritized refreshing is provided in the following figure.

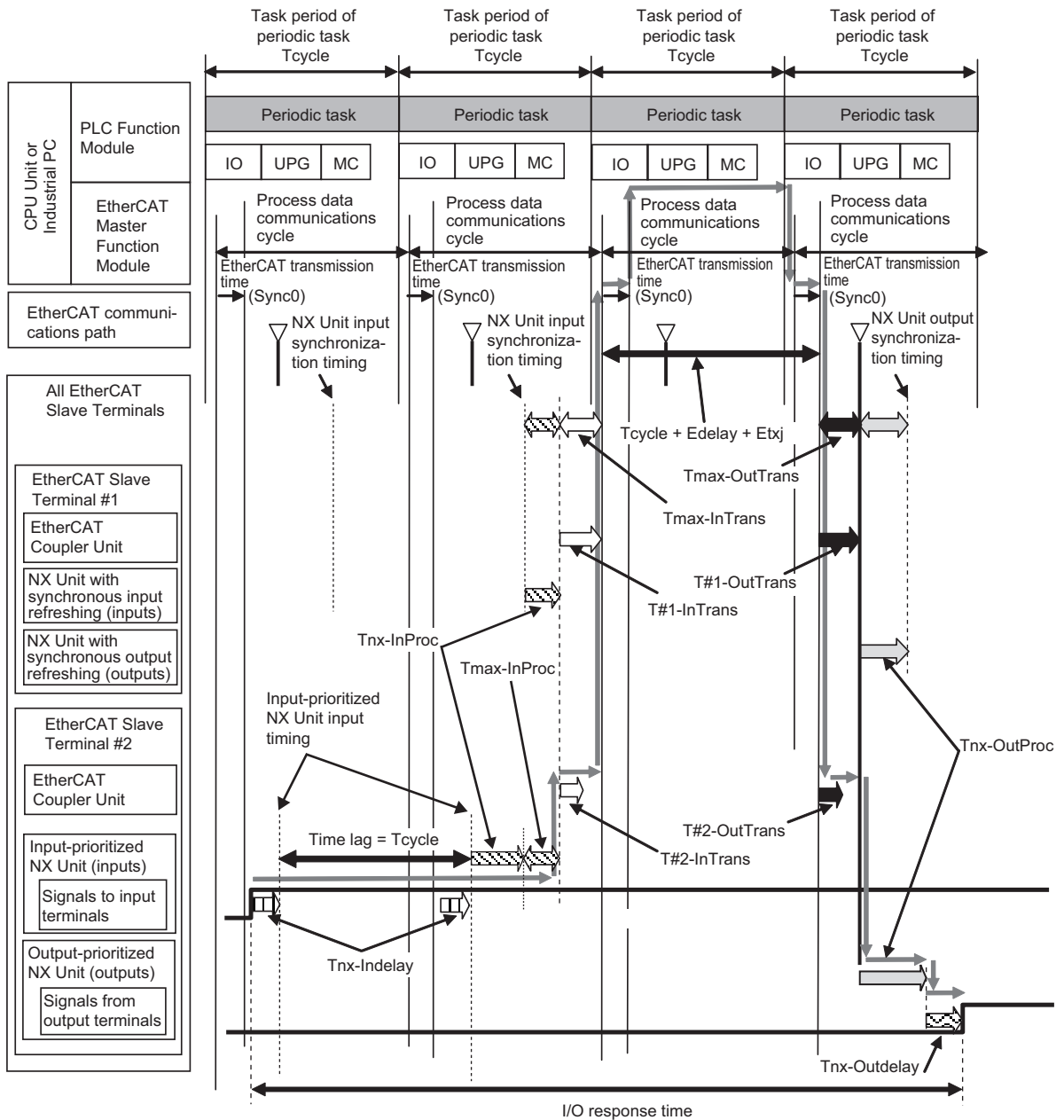

The maximum and minimum NX values of the I/O response time are calculated as shown below. The minimum value occurs when the time lag that is shown in the above figure does not occur.

Formula: Maximum I/O response time =	$T_{cycle} \times 2 + E_{delay} + E_{tj} + T_{max-InTrans} + T_{max-OutTrans} + T_{max-InProc} + T_{nx-InProc} + T_{nx-OutProc} + T_{nx-Indelay} + T_{nx-Outdelay}$
--------------------------------------	---

Formula: Minimum I/O response time =	$T_{cycle} + E_{delay} + E_{tj} + T_{max-InTrans} + T_{max-OutTrans} + T_{max-InProc} + T_{nx-InProc} + T_{nx-OutProc} + T_{nx-Indelay} + T_{nx-Outdelay}$
--------------------------------------	--

If you perform I/O refreshing for EtherCAT Slave Terminals at a built-in EtherCAT port that supports process data communications with a Slave Terminal in more than one periodic task, calculate the I/O response times for each EtherCAT Slave Terminal for the task period of each periodic task of the CPU Unit that performs the I/O refreshing.

The elements in the formulas are as follows:

- Tcycle: Task period of the periodic task in the CPU Unit or Industrial PC
- Edelay: Transmission delay time of the EtherCAT master
- Etxj: Transmission jitter of the EtherCAT master
- Tmax-InTrans: Longest input data transmission time of all of the EtherCAT Coupler Units.
- Tmax-OutTrans: Longest output data transmission time of all of the EtherCAT Coupler Units.
- Tmax-InProc: Longest input data processing time of all of the NX Units.
- Tnx-InProc: Input data processing time of the NX Unit
- Tnx-OutProc: Output data processing time of the NX Unit
- Tnx-Indelay: Input delay time of the NX Unit
- Tnx-Outdelay: Output delay time of the NX Unit



### Additional Information

The figure in *Timing Chart and Configuration Elements of the I/O Response Time* on page 12-16 shows an example in which the NX Units with synchronous I/O refreshing are in the same EtherCAT network as NX Units with time stamp refreshing. The formula for when only NX Units with task period prioritized refreshing are in an EtherCAT network is the same as the formula in *Timing Chart and Configuration Elements of the I/O Response Time* on page 12-16.

## Definition of Formula Elements and Calculation Methods

This section defines the calculation formula elements and describes the calculation methods.

Tcycle, Edelay, Etxj, Tmax-InTrans, and Tmax-OutTrans are the same in terms of definitions and calculation methods as the elements for calculating the I/O response time for synchronous I/O refreshing. In the calculations of Tmax-InTrans and Tmax-OutTrans, select the formula for an NX-ECC203 EtherCAT Coupler Unit, which supports task period prioritized refreshing. Refer to *Definitions of Formula Elements and Calculation Methods* on page 12-5 in *12-1-1 I/O Response Times for Synchronous I/O Refreshing* on page 12-2 for the definitions and calculation methods for these elements.

### ● Tmax-InProc

In the calculations of the I/O response time for task period prioritized refreshing, Tmax-InProc is added. Tmax-InProc is an element of the I/O response time for synchronous I/O refreshing and time stamp refreshing. Refer to *Definitions of Formula Elements and Calculation Methods* on page 12-5 in *12-1-1 I/O Response Times for Synchronous I/O Refreshing* on page 12-2 for the method to calculate Tmax-InProc.

### ● Tnx-InProc

This is the input data processing time of the NX Unit. It is the time from reading the status of the NX Unit input terminals into memory until preparations to pass the read data to the EtherCAT Coupler Unit are completed. There is a unique value for each type of NX Unit. Refer to the appendix of the *NX-series Data Reference Manual (Cat. No. W525)* for the values of Tnx-InProc for NX Units that operate with input prioritized refreshing for task period prioritized refreshing.

### ● Tnx-OutProc

This is the output data processing time of the NX Unit. It is the time from when the NX Unit reads the output data that was sent by the EtherCAT Coupler Unit until preparations to update the output data are completed. There is a unique value for each type of NX Unit. Refer to the appendix of the

*NX-series Data Reference Manual (Cat. No. W525)* for the values of Tnx-OutProc for NX Units that operate with output prioritized refreshing for task period prioritized refreshing.

### ● Tnx-Indelay

This is the input delay time of the NX Unit. It is the time required for the NX Unit to read the status of the input terminals into NX Unit memory. There is a unique value for each type of NX Unit. Refer to the appendix of the *NX-series Data Reference Manual (Cat. No. W525)* for the values of Tnx-Indelay for NX Units that operate with output prioritized refreshing for task period prioritized refreshing.

### ● Tnx-Outdelay

This is the output delay time of the NX Unit. This is the time to change the output terminals according to the updated output data in the NX Unit. There is a unique value for each type of NX Unit. Refer to the appendix of the *NX-series Data Reference Manual (Cat. No. W525)* for the values of Tnx-Outdelay for NX Units that operate with output prioritized refreshing for task period prioritized refreshing.

## Calculation Precautions

Refer to *Calculation Precautions* on page 12-11 in *12-1-1 I/O Response Times for Synchronous I/O Refreshing* on page 12-2 for calculation precautions.

## Calculation Example

This section provides a calculation example for I/O response times.

### ● Calculation Conditions

Calculations are made for the following conditions.

#### a. Configuration

The following configuration is used. In this example, an NX-series NX701 CPU Unit with project unit version earlier than 1.40 in the Sysmac Studio project is used to refresh I/O with an EtherCAT Slave Terminal. The total cable length is 50 m.

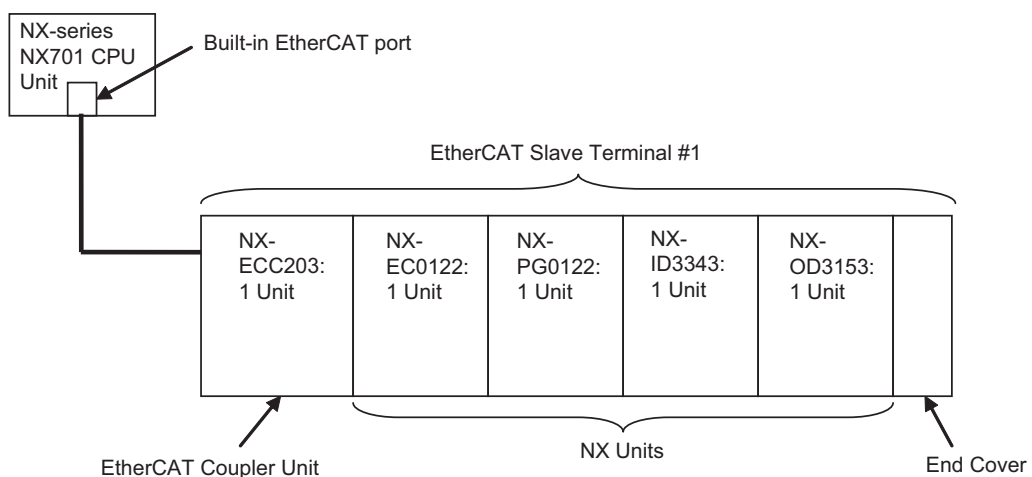

- b. With the above configuration, the I/O response time is calculated as the time from when the CPU Unit processes an external input signal to the NX-EC0122 until the signal is output from the NX-PG0122.
- c. It is assumed that  $T_{\text{cycle}}$  is set to 250  $\mu\text{s}$ .
- d. The I/O refreshing method for the NX Unit is as follows:

NX Unit	I/O refreshing method
NX-EC0122*1	Task period prioritized refreshing
NX-PG0122*1	
NX-ID3343	Synchronous I/O refreshing
NX-OD3153	

\*1. The unit version is 1.2 or later.

- e. The default I/O allocation settings are used for the EtherCAT Slave Terminal.
- f. It is assumed that I/O refreshing for the EtherCAT Slave Terminal is performed in the primary periodic task of the NX701 CPU Unit.
- g. The power supply design conditions are not considered in this calculation example.

## ● Unit Configuration and Data Sizes in the EtherCAT Slave Terminal

The unit configuration and data sizes in the EtherCAT Slave Terminal are given in the following table.

Unit type	Model number	Number of Units	Byte size of input data	Byte size of output data	No. of NX Units with BOOL input data	No. of NX Units with BOOL output data
EtherCAT Coupler Unit	NX-ECC203	1	18	0	-	-
Incremental Encoder Input Units	NX-EC0122	1	18	4	0	-
Pulse Output Units	NX-PG0122	1	18	14	-	0
Digital Input Units	NX-ID3343	1	0.5	0	1	-
Digital Output Units	NX-OD3153	1	0	0.5	-	1
Total for EtherCAT Slave Terminal		5	54.5	18.5	-	-
Total for NX Units		4	36.5	18.5	1	1

There are no NX-OD2154 or NX-OD2258 Units, which support output refreshing with specified time stamps, in the configuration example.

## ● Calculating the Elements of the I/O Response Times

This section shows how to calculate the elements of the I/O response times.

- a. Calculating Edelay

The calculation method with a formula is described here. Edelay can also be calculated with the Sysmac Studio because this is an example of performing I/O refreshing of an EtherCAT Slave Terminal in the primary periodic task of an NX701 CPU Unit. Refer to *Displaying the Transmission Delay Times of the EtherCAT Master* on page 9-34 in *9-2-7 Sysmac Studio Functions Used as Required* on page 9-28 for details on the calculation method with the Sysmac Studio.

The following parameters are required to calculate the value.

Parameter	Value	Remarks
Number of EtherCAT slaves	1*1	An EtherCAT Slave Terminal is counted as one EtherCAT slave.
EtherCAT frame length in bytes	64 bytes*1	The EtherCAT Slave Terminal has a total input data size of 54.5 bytes and a total output data size of 18.5 bytes. Both the input data size and output data size are less than 64 bytes, so 64 bytes is used.
Total Cable Length (m)	50 m	The value is for this configuration example.

\*1. Refer to *Unit Configuration and Data Sizes in the EtherCAT Slave Terminal* on page 12-20 for the parameter values.

Therefore, the value of  $E_{delay}$  is as follows:

Formula:	=	$1.24 \times \text{Number of EtherCAT slaves}$
$E_{delay}$	+	$0.082 \times \text{EtherCAT frame length in bytes}$
	+	$0.01 \times \text{Total cable length (m)}$
	=	$1.24 \times 1 \text{ unit} + 0.082 \times 64 \text{ bytes} + 0.01 \times 50 \text{ m}$
	=	6.988
	≈	7
		(Unit: $\mu\text{s}$ )

b. Calculating  $E_{txj}$

The value of  $E_{txj}$  is fixed. The value is given below. The value for an NX701 CPU Unit is used.

Formula:	$E_{txj} = 10$
	(Unit: $\mu\text{s}$ )

c. Calculating  $T_{max-InTrans}$

There is only one EtherCAT Slave Terminal, so the value is as follows:

$$T_{max-InTrans} = T\#1-InTrans$$

The following parameters are required to calculate  $T\#1-InTrans$ .

Parameter	Value	Remarks
Total byte size of the input data of the NX Unit	36.5 bytes	This is the total input data size of the NX Unit.
Number of NX Units	4 Units	-
Number of NX Units with BOOL input data	1 Unit	-

Refer to *Unit Configuration and Data Sizes in the EtherCAT Slave Terminal* on page 12-20 for the values of the above parameters.

Therefore, the value of  $T_{max-InTrans}$  is as follows: The calculation formula for the NX-ECC203 is used.

Formula: Tmax-In-Trans	=	T#1-InTrans
	=	5.92 × (Integer quotient of <i>total byte size of the input data of the NX Unit</i> ÷ 32)
		+ 0.19 × (Remainder of <i>total byte size of the input data of the NX Unit</i> ÷ 32)
		+ (0.36 × <i>Number of NX Units with BOOL input data</i> + 1.19)
		+ 2.15 × <i>Number of NX Units</i>
		+ 0.15 × <i>Total byte size of NX Unit input data</i>
		+ 35.85
	=	5.92 × (Integer quotient of 36.5 bytes ÷ 32)
		+ 0.19 × (Remainder of 36.5 bytes ÷ 32)
		+ (0.36 × 1 Unit + 1.19) + 2.15 × 4 Units
		+ 0.15 × 36.5 bytes + 35.85
	=	5.92 × 1.00 + 0.19 × 4.50 + (0.36 × 1 Unit + 1.19)
		+ 2.15 × 4 Units + 0.15 × 36.5 bytes + 35.85
	=	58.25

(Unit: μs)

## d. Calculating Tmax-OutTrans

There is only one EtherCAT Slave Terminal, so the value is as follows:

$$T_{\max\text{-OutTrans}} = T_{\#1\text{-OutTrans}}$$

The following parameters are required to calculate T#1-OutTrans.

Parameter	Value	Remarks
Total byte size of the output data of the NX Unit	18.5 bytes	This is the total output data size of the NX Unit.
Number of NX Units	4 Units	-
Number of NX Units with BOOL output data	1 Unit	-

Refer to *Unit Configuration and Data Sizes in the EtherCAT Slave Terminal* on page 12-20 for the values of the above parameters.

Therefore, the value of Tmax-OutTrans is as follows:

Formula: Tmax-Out-Trans	=	T#1-OutTrans
	=	6.08 × (Integer quotient of <i>total byte size of the output data of the NX Unit</i> ÷ 32) + 0.19 × (Remainder of <i>total byte size of the output data of the NX Unit</i> ÷ 32)
		+ (0.31 × <i>Number of NX Units with BOOL output data</i> + 1.22)
		+ (3.31 × <i>Number of NX Units with output refreshing with specified time stamps</i> + 2.80) + 0.38 × <i>Number of NX Units</i> + 0.15 × <i>Total byte size of NX Unit output data</i> + 17.76
	=	6.08 × (Integer quotient of 18.5 bytes ÷ 32) + 0.19 × (Remainder of 18.5 bytes ÷ 32)
		+ (0.31 × 1 Unit + 1.22) + 0 + 0.38 × 4 Units + 0.15 × 18.5 bytes + 17.76
	=	6.08 × 0.00 + 0.19 × 18.50 + (0.31 × 1 Unit + 1.22) + 0
		+ 0.38 × 4 Units + 0.15 × 18.5 bytes + 17.76
	=	27.10

(Unit: μs)

## e. Calculating Tmax-InProc

The NX-EC0122 Incremental Encoder Input Unit and NX-PG0122 Pulse Output Unit use task period prioritized refreshing, so they are not included in this calculation. Tnx-InProc of an NX-ID3343 Digital Input Unit with synchronous I/O refreshing is 0 μs.

Therefore, the value of Tmax-InProc is as follows:

Formula: Tmax-InProc = 0.00

(Unit:  $\mu\text{s}$ )

f. Calculating Tnx-InProc

Tnx-InProc of an NX-EC0122 Incremental Encoder Input Unit is 85  $\mu\text{s}$ .

Therefore, the value of Tnx-InProc is as follows:

Formula: Tnx-InProc = 85.00

(Unit:  $\mu\text{s}$ )

g. Calculating Tnx-OutProc

Tnx-OutProc of an NX-PG0122 Pulse Output Unit is 70  $\mu\text{s}$ .

Therefore, the value of Tnx-OutProc is as follows:

Formula: Tnx-OutProc = 70.00

(Unit:  $\mu\text{s}$ )

h. Calculating Tnx-Indelay

Tnx-Indelay of an NX-EC0122 Incremental Encoder Input Unit is 0  $\mu\text{s}$ .

Therefore, the value of Tnx-Indelay is as follows:

Formula: Tnx-Indelay = 0.00

(Unit:  $\mu\text{s}$ )

i. Calculating Tnx-Outdelay

Tnx-Outdelay of an NX-PG0122 Pulse Output Unit is 0  $\mu\text{s}$ .

Therefore, the value of Tnx-Outdelay is as follows:

Formula: Tnx-Outdelay = 0.00

(Unit:  $\mu\text{s}$ )

### ● Calculating the I/O Response Times

The I/O response times are as follows based on the calculation results for the elements.

Formula: Maximum I/O response time	$= T_{\text{cycle}} \times 2 + E_{\text{delay}} + E_{\text{tj}} + T_{\text{max-InTrans}} + T_{\text{max-OutTrans}} + T_{\text{max-InProc}} + T_{\text{nx-InProc}} + T_{\text{nx-OutProc}} + T_{\text{nx-Indelay}} + T_{\text{nx-Outdelay}}$ $= 250 \times 2 + 7 + 10 + 58.25 + 27.10 + 0.00 + 85.00 + 70.00 + 0.00 + 0.00$ $= 757.35$
	(Unit: $\mu\text{s}$ )

Formula: Minimum I/O response time	$= T_{\text{cycle}} + E_{\text{delay}} + E_{\text{tj}} + T_{\text{max-InTrans}} + T_{\text{max-OutTrans}} + T_{\text{max-InProc}} + T_{\text{nx-InProc}} + T_{\text{nx-OutProc}} + T_{\text{nx-Indelay}} + T_{\text{nx-Outdelay}}$ $= 250 + 7 + 10 + 58.25 + 27.10 + 0.00 + 85.00 + 70.00 + 0.00 + 0.00$ $= 507.35$
	(Unit: $\mu\text{s}$ )

## 12-1-3 I/O Response Times for Time Stamp Refreshing

This section describes the I/O response times of NX Units on EtherCAT Slave Terminals under the following conditions.

Item	Condition
CPU Unit or Industrial PC periodic task in which I/O is refreshed	Primary periodic task or priority-5 periodic task <sup>*1</sup>

Item	Condition
I/O refreshing mode	DC Mode
I/O refreshing method for NX Units	Time stamp refreshing

\*1. The connected CPU Unit or Industrial PC must support a priority-5 periodic task. For example, NX701 CPU Units support them. Refer to *Assignment and Settings Related to Tasks* in the software user's manual for the connected CPU Unit or Industrial PC for information on the periodic tasks that are supported by the CPU Unit or Industrial PC.

The I/O response time for time stamp refreshing is the specific time required to produce the output after the input changed time. You specify the time in the user program. Specify a time that has sufficient leeway to ensure that the output is produced at the expected time.

The minimum specified time for which the expected output is produced is defined as the maximum I/O response time for time stamp refreshing. It is described in this section.

With input refreshing with input changed times for time stamp refreshing, when there is more than one EtherCAT Slave Terminal in the same EtherCAT network, the inputs for all of the NX Units that operate with synchronous input refreshing and the changed times for all of the NX Units that operate with input refreshing with input changed times on the EtherCAT Slave Terminals for which I/O is refreshed in the same periodic task are read at the same time.

Therefore, when you calculate the I/O response times for an NX Unit on an EtherCAT Slave Terminal, you must use in the calculations the longest elements for the EtherCAT Slave Terminals that are refreshed in the same periodic task.

Refer to *10-3-4 I/O Refreshing Method Operation* on page 10-10 for details on the operation of time stamp refreshing.

## Prerequisites for Calculations

These are the same as the prerequisites for calculating the I/O response time for synchronous I/O refreshing.

Refer to *Prerequisites for Calculations* on page 12-3 in *12-1-1 I/O Response Times for Synchronous I/O Refreshing* on page 12-2 for the prerequisites for calculations.

## Timing Chart and Configuration Elements of the I/O Response Time

A timing chart for the maximum I/O response time with time stamp refreshing is provided in the following figure.

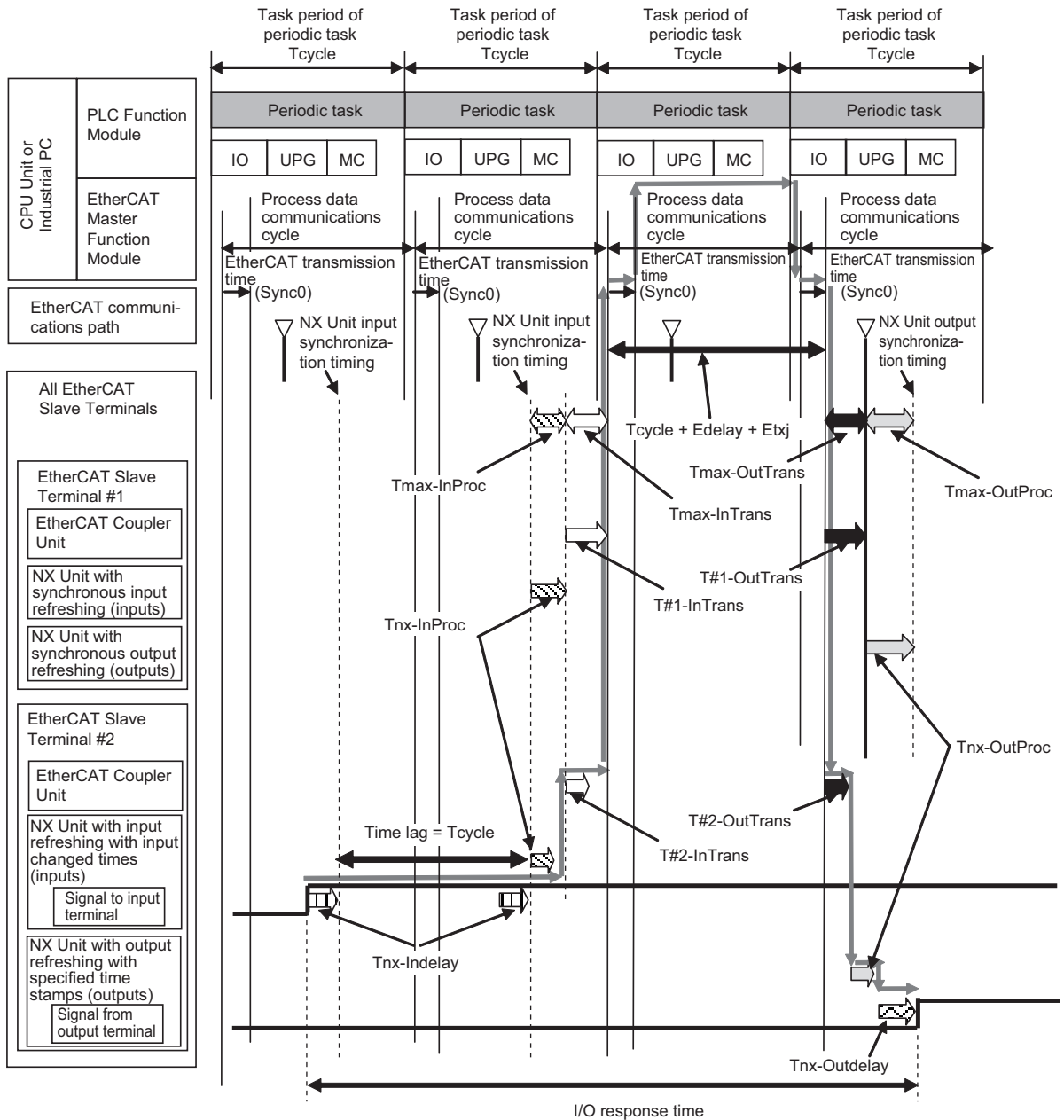

The maximum I/O response time is given below.

<p>Formula: Maximum I/O response time = <math>T_{cycle} \times 2 + E_{delay} + E_{txj} + T_{max-InTrans} + T_{\#n-OutTrans}^{*1} + T_{max-InProc} + T_{nx-OutProc} + T_{nx-Indelay} + T_{nx-Outdelay}</math></p>
--

\*1. In the example in the above figure, this is the output data transmission time ( $T_{\#2-OutTrans}$ ) of the EtherCAT Coupler Unit in the EtherCAT Slave Terminal with node address 2.

If you perform I/O refreshing for EtherCAT Slave Terminals at a built-in EtherCAT port that supports process data communications with a Slave Terminal in more than one periodic task, calculate the I/O response times for each EtherCAT Slave Terminal for the task period of each periodic task of the CPU Unit that performs the I/O refreshing.

The elements in the formulas are as follows:

- $T_{cycle}$ : Task period of the periodic task in the CPU Unit or Industrial PC
- $E_{delay}$ : Transmission delay time of the EtherCAT master
- $E_{txj}$ : Transmission jitter of the EtherCAT master

- Tmax-InTrans: Longest input data transmission time of all of the EtherCAT Coupler Units.
- T#n-OutTrans: Output data transmission time of the EtherCAT Coupler Unit in the EtherCAT Slave Terminal with node address n.
- Tmax-InProc: Longest input data processing time of all of the NX Units.
- Tnx-OutProc: Output data processing time of the NX Unit
- Tnx-Indelay: Input delay time of the NX Unit
- Tnx-Outdelay: Output delay time of the NX Unit



### Precautions for Correct Use

Specify a time that has sufficient leeway to ensure that the output is produced at the expected time. If you specify times, you must use the status of the Output Units with output refreshing with specified time stamps when you create the user program. Refer to the manuals for the specific NX Units for details on the specifications and operation of time stamp refreshing.



### Additional Information

The figure in *Timing Chart and Configuration Elements of the I/O Response Time* on page 12-24 shows an example in which the NX Units with synchronous I/O refreshing are on the same EtherCAT network as NX Units with time stamp refreshing. The formula for when only NX Units with time stamp refreshing are on an EtherCAT network is the same as the formula in *Timing Chart and Configuration Elements of the I/O Response Time* on page 12-24.

## Definition of Formula Elements and Calculation Methods

This section defines the calculation formula elements and describes the calculation methods.

Tcycle, Edelay, Etxj, and Tmax-InTrans are the same in terms of definitions and calculation methods as the elements for calculating the I/O response time for synchronous I/O refreshing. Refer to *Definitions of Formula Elements and Calculation Methods* on page 12-5 in *12-1-1 I/O Response Times for Synchronous I/O Refreshing* on page 12-2 for the definitions and calculation methods for these elements.

### ● T#n-OutTrans

This is the output data transmission time of the EtherCAT Coupler Unit in the EtherCAT Slave Terminal with node address n. The output data transmission time is the time that is required for the EtherCAT Coupler Unit to read the output data from the EtherCAT communications path and send the data to the NX Units.

Refer to *Definitions of Formula Elements and Calculation Methods* on page 12-5 in *12-1-1 I/O Response Times for Synchronous I/O Refreshing* on page 12-2 for the formula for T#n-OutTrans. Use the formula for T#n-OutTrans in the description of Tmax-OutTrans in the referenced section.

### ● Tmax-InProc

This is the longest time in the NX Unit input processing times (Tnx-InProc) in the EtherCAT Slave Terminals in the same EtherCAT network and for which I/O is refreshed in the same periodic task. This is the longest time of the NX Units that operate with the following I/O refresh methods in the calculations of the I/O response times for time stamp refreshing.

- Synchronous I/O refreshing
- Input refreshing with input changed time for time stamp refreshing

Calculations of NX Units that operate with Free-Run refreshing or task period prioritized refreshing are not included.

The input data processing time of an NX Unit (Tnx-InProc) is the time from reading the status of the NX Unit input terminals into memory until preparations to pass the read data to the EtherCAT Coupler Unit are completed. There is a unique value for each type of NX Unit. With input refreshing with input changed times for time stamp refreshing, this is the time from the NX Unit input synchronization timing until preparations to pass the input changed times to the EtherCAT Coupler Unit are completed. The NX Unit input synchronization timing is when all NX Units with synchronous input refreshing simultaneously read the inputs and all NX Units with input refreshing with input changed times simultaneously read the input changed times in the EtherCAT Slave Terminals in the same EtherCAT network and for which I/O is refreshed in the same periodic task.

Refer to the appendix of the *NX-series Data Reference Manual (Cat. No. W525)* for the values of Tnx-InProc for NX Units that operate with synchronous I/O refreshing or with input refreshing with input changed time for time stamp refreshing.

- **Tnx-OutProc**

This is the output data processing time of the NX Unit. It is the time from when the NX Unit reads the output data that was sent by the EtherCAT Coupler Unit until preparations to update the output data are completed. There is a unique value for each type of NX Unit. Refer to the appendix of the *NX-series Data Reference Manual (Cat. No. W525)* for the values of Tnx-OutProc for NX Units that operate with output refreshing with specified time stamp for time stamp refreshing.

- **Tnx-Indelay**

This is the input delay time of the NX Unit. It is the time required for the NX Unit to read the status of the input terminals into NX Unit memory. There is a unique value for each type of NX Unit. Refer to the appendix of the *NX-series Data Reference Manual (Cat. No. W525)* for the values of Tnx-Indelay for NX Units that operate with input refreshing with input changed time for time stamp refreshing.

- **Tnx-Outdelay**

This is the output delay time of the NX Unit. This is the time to change the output terminals according to the updated output data in the NX Unit. There is a unique value for each type of NX Unit. Refer to the appendix of the *NX-series Data Reference Manual (Cat. No. W525)* for the values of Tnx-Outdelay for NX Units that operate with output refreshing with specified time stamp for time stamp refreshing.

## Calculation Precautions

Refer to *Calculation Precautions* on page 12-11 in *12-1-1 I/O Response Times for Synchronous I/O Refreshing* on page 12-2 for calculation precautions.

### 12-1-4 I/O Response Times for Free-Run Refreshing

This section describes the I/O response times of NX Units on EtherCAT Slave Terminals under the following conditions.

Item	Condition
CPU Unit or Industrial PC periodic task in which I/O is refreshed	Primary periodic task and priority-5 periodic task* <sup>1</sup>
I/O refreshing mode	Free-Run Mode
I/O refreshing method for NX Units	Free-Run refreshing

\*1. The connected CPU Unit or Industrial PC must support a priority-5 periodic task. For example, NX701 CPU Units support them. Refer to *Assignment and Settings Related to Tasks* in the software user's manual for the connected CPU Unit or Industrial PC for information on the periodic tasks that are supported by the CPU Unit or Industrial PC.

The I/O response time is the time required for the following processing: The CPU Unit or Industrial PC processes an external signal input to one NX Unit, and another NX Unit outputs the processed result as an external signal.

With Free-Run refreshing, the refresh cycle of the NX bus and the I/O refresh cycle of the NX Units operate asynchronously. In Free-Run Mode, the NX bus refresh cycle is not synchronized with the task period of the periodic task or process data communications cycle. The NX bus operates on its own cycle. Refer to *Section 10 I/O Refreshing* on page 10-1 for details on the operation of Free-Run refreshing and synchronous I/O refreshing.

## Prerequisites for Calculations

The calculations that are described in this section assume that the following conditions are met.

- a. Sequence control and motion control in the NJ/NX-series CPU Unit or Industrial PC are performed within the task period of the periodic task in which EtherCAT communications were refreshed.
- b. If you use an NX Unit that has restrictions in the communications cycle in Free-Run Mode, it must be set to a task period for a communications cycle that will satisfy the specifications for the refresh cycles that can be executed by the NX Unit.

You can check for condition (a) by estimating the task execution time. For the checking procedure, refer to the section on *designing tasks* in the software user's manual for the connected CPU Unit or Industrial PC.

For condition (b), refer to the appendix of the *NX-series Data Reference Manual (Cat. No. W525)* to see if there are restrictions on any specific NX Units. If there are restrictions, refer to the user's manual for the NX Unit, and confirm that the task period satisfies the specifications for the refresh cycles that can be executed by the NX Unit.

## Timing Chart and Configuration Elements of the I/O Response Time

A timing chart for the I/O response time with Free-Run refreshing is provided in the following figure. This timing chart shows the maximum I/O response time.

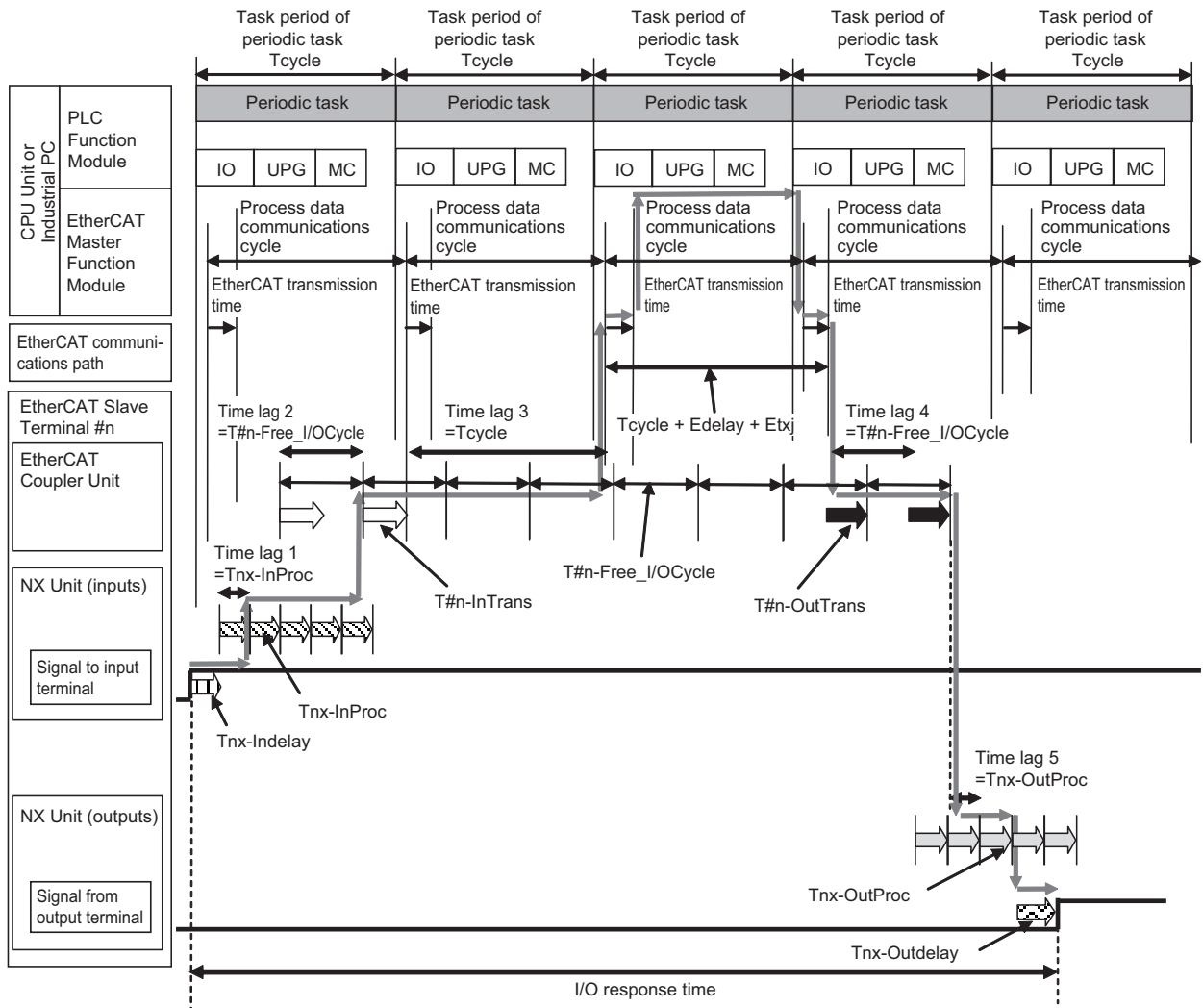

The maximum and minimum values of the I/O response time are calculated as shown below. The minimum value occurs when the time lags that are shown in the above figure do not occur.

Formula: Maximum I/O response time =	$T_{cycle} \times 2 + E_{delay} + E_{txj} + T_{\#n-Free\_I/OCycle} \times 2 + T_{\#n-InTrans} + T_{\#n-OutTrans} + T_{nx-InProc} \times 2 + T_{nx-OutProc} \times 2 + T_{nx-Indelay} + T_{nx-Outdelay}$
--------------------------------------	---

Formula: Minimum I/O response time =	$T_{cycle} + E_{delay} + E_{txj} + T_{\#n-InTrans} + T_{\#n-OutTrans} + T_{nx-InProc} + T_{nx-OutProc} + T_{nx-Indelay} + T_{nx-Outdelay}$
--------------------------------------	--

If you perform I/O refreshing for EtherCAT Slave Terminals at a built-in EtherCAT port that supports process data communications with a Slave Terminal in more than one periodic task, calculate the I/O response times for each EtherCAT Slave Terminal for the task period of each periodic task of the CPU Unit that performs the I/O refreshing.

The elements in the formulas are as follows: “#n” indicates the node address of the EtherCAT Slave Terminal. “n” is the address.

- Tcycle: Task period of the periodic task in the CPU Unit or Industrial PC
- Edelay: Transmission delay time of the EtherCAT master
- Etxj: Transmission jitter of the EtherCAT master
- T#n-InTrans: Input data transmission time of the EtherCAT Coupler Unit in the EtherCAT Slave Terminal with node address n.

- **T#n-OutTrans**: Output data transmission time of the EtherCAT Coupler Unit in the EtherCAT Slave Terminal with node address n.
- **T#n-Free\_I/OCycle**: Refresh cycle of NX bus in EtherCAT Slave Terminal in Free-Run Mode.
- **Tnx-InProc**: Input data processing time of the NX Unit
- **Tnx-OutProc**: Output data processing time of the NX Unit
- **Tnx-Indelay**: Input delay time of the NX Unit
- **Tnx-Outdelay**: Output delay time of the NX Unit

## Definition of Formula Elements and Calculation Methods

This section defines the elements and describes the calculation methods.

### ● **Tcycle**

This is the time that is set for the task period of the periodic task in the CPU Unit or Industrial PC.

### ● **Edelay**

This is the transmission delay time of the EtherCAT master. Refer to *Definitions of Formula Elements and Calculation Methods* on page 12-5 in *12-1-1 I/O Response Times for Synchronous I/O Refreshing* on page 12-2 for the calculation methods for Edelay.

### ● **Etj**

This is the transmission jitter of the EtherCAT master. Refer to *Definitions of Formula Elements and Calculation Methods* on page 12-5 in *12-1-1 I/O Response Times for Synchronous I/O Refreshing* on page 12-2 for the values of Etj.

### ● **T#n-InTrans**

This is the input data transmission time of the EtherCAT Coupler Unit in the EtherCAT Slave Terminal with node address n. The input data transmission time is the time that is required for the EtherCAT Coupler Unit to read all of the input data for all of the NX Units. After all of the input data is read, the EtherCAT Coupler Unit is ready to send the data to the EtherCAT communications path. Refer to *Definitions of Formula Elements and Calculation Methods* on page 12-5 in *12-1-1 I/O Response Times for Synchronous I/O Refreshing* on page 12-2 for the formula for T#n-InTrans. Use the formula for T#n-InTrans in the description of Tmax-InTrans in the referenced section.

### ● **T#n-OutTrans**

This is the output data transmission time of the EtherCAT Coupler Unit in the EtherCAT Slave Terminal with node address n. The output data transmission time is the time that is required for the EtherCAT Coupler Unit to read the output data from the EtherCAT communications path and send the data to the NX Units.

Refer to *Definitions of Formula Elements and Calculation Methods* on page 12-5 in *12-1-1 I/O Response Times for Synchronous I/O Refreshing* on page 12-2 for the formula for T#n-OutTrans. Use the formula for T#n-OutTrans in the description of Tmax-OutTrans in the referenced section.

### ● **T#n-Free\_I/OCycle**

This is the refresh cycle of the NX bus in the EtherCAT Slave Terminal with node address #n in Free-Run Mode. Use the following formula.

Formula:  $T\#n\text{-Free\_I/OCycle} = T\#n\text{-InTrans} + T\#n\text{-OutTrans} + T\#n\text{-exsoft}$

(Unit:  $\mu\text{s}$ )

Refer to  $T\#n\text{-InTrans}$  on page 12-30 and to  $T\#n\text{-OutTrans}$  on page 12-30 for the definitions of and calculation methods for  $T\#n\text{-InTrans}$  and  $T\#n\text{-OutTrans}$ . Here, the calculation method for  $T\#n\text{-exsoft}$  is described.

$T\#n\text{-exsoft}$  is the internal processing time in the EtherCAT Coupler Unit in the EtherCAT Slave Terminal with node address  $n$  in Free-Run Mode.

The formula to calculate  $T\#n\text{-exsoft}$  depends on the model of the EtherCAT Coupler Unit. Use the calculation formula for the EtherCAT Coupler Unit that you will use.

a. NX-ECC203

Use the following formula.

Formula:  $T\#n\text{-exsoft} = 25.72 + \{0.3 \times \{T\#n\text{-InTrans} + T\#n\text{-OutTrans} + (0.03 \times \text{Number of NX Units}^{*1}) + 31.94\}\} \div 0.7$

(Unit:  $\mu\text{s}$ )

\*1. This is the number of NX Units in the EtherCAT Slave Terminal with node address  $\#n$ .

b. NX-ECC201 or NX-ECC202

Use the following formula.

Formula:  $T\#n\text{-exsoft} = 60 + \{0.3 \times \{T\#n\text{-InTrans} + T\#n\text{-OutTrans} + (0.75 \times \text{Number of NX Units}^{*1}) + 54\}\} \div 0.7$

(Unit:  $\mu\text{s}$ )

\*1. This is the number of NX Units in the EtherCAT Slave Terminal with node address  $\#n$ .

### ● Tnx-InProc

This is the input data processing time of the NX Unit. It is the time from reading the status of the NX Unit input terminals into memory until preparations to pass the read data to the EtherCAT Coupler Unit are completed. There is a unique value for each type of NX Unit.

The NX Unit input data processing time depends on the NX Unit. Refer to the appendix of the *NX-series Data Reference Manual (Cat. No. W525)* for the values of Tnx-InProc for NX Units that operate with Free-Run refreshing.

### ● Tnx-OutProc

This is the output data processing time of the NX Unit. It is the time from when the NX Unit reads the output data that was sent by the EtherCAT Coupler Unit until preparations to update the output data are completed. There is a unique value for each type of NX Unit.

The NX Unit output data processing time depends on the NX Unit. Refer to the appendix of the *NX-series Data Reference Manual (Cat. No. W525)* for the values of Tnx-OutProc for NX Units that operate with Free-Run refreshing.

### ● Tnx-Indelay

This is the input delay time of the NX Unit. It is the time required to read the status of the input terminals into NX Unit memory.

The NX Unit input delay time depends on the NX Unit. Refer to the appendix of the *NX-series Data Reference Manual (Cat. No. W525)* for the values of Tnx-Indelay for NX Units that operate with Free-Run refreshing.

### ● Tnx-Outdelay

This is the output delay time of the NX Unit. This is the time to change the output terminals according to the updated output data in the NX Unit. There is a unique value for each type of NX Unit. The NX Unit output delay time depends on the NX Unit. Refer to the appendix of the *NX-series Data Reference Manual (Cat. No. W525)* for the values of Tnx-Outdelay for NX Units that operate with Free-Run refreshing.

## Calculation Precautions

Refer to *Calculation Precautions* on page 12-11 in *12-1-1 I/O Response Times for Synchronous I/O Refreshing* on page 12-2 for the formula for calculation precautions.

## Calculation Example

This section provides a calculation example for I/O response times.

### ● Calculation Conditions

The conditions are the same as those for calculating the I/O response time for synchronous I/O refreshing. Refer to *Calculation Example* on page 12-11 and *Calculation Conditions* on page 12-12 in *12-1-1 I/O Response Times for Synchronous I/O Refreshing* on page 12-2 for details.

### ● Unit Configuration and Data Sizes in the EtherCAT Slave Terminal

These are the same as those for calculating the I/O response time for synchronous I/O refreshing. Refer to *Calculation Example* on page 12-11 and *Unit Configuration and Data Sizes in the EtherCAT Slave Terminal* on page 12-12 in *12-1-1 I/O Response Times for Synchronous I/O Refreshing* on page 12-2 for details.

### ● Calculating the Elements of the I/O Response Times

This section shows how to calculate the elements of the I/O response times.

Because the calculation conditions are the same as for calculating the I/O response time for synchronous I/O refreshing, a description of the required parameters is omitted here and only the calculation results are given. Refer to *Calculation Example* on page 12-11 and *Calculating the Elements of the I/O Response Times* on page 12-13 in *12-1-1 I/O Response Times for Synchronous I/O Refreshing* on page 12-2 for a description of the parameters required for the calculation.

#### a. Calculating Edelay

The value of Edelay is as follows:

$$\begin{aligned}
 \text{Formula:} &= 1.24 \times \text{Number of EtherCAT slaves} \\
 \text{Edelay} &+ 0.082 \times \text{EtherCAT frame length in bytes} \\
 &+ 0.01 \times \text{Total cable length (m)} \\
 &= 1.24 \times 1 \text{ unit} + 0.082 \times 64 \text{ bytes} + 0.01 \times 50 \text{ m} \\
 &= 6.988 \\
 &\approx 7
 \end{aligned}$$

(Unit:  $\mu\text{s}$ )

## b. Calculating Etxj

The value of Etxj is fixed. The value is given below.

$$\text{Formula: Etxj} = 100$$

(Unit:  $\mu\text{s}$ )

## c. Calculating T#1-InTrans

The value of T#1-InTrans is as follows:

$$\begin{aligned}
 \text{Formula: T\#1-In-} &= 9.22 \times (\text{Integer quotient of total byte size of the input data of the NX Unit} \div 32) \\
 \text{Trans} &+ 0.55 \times (\text{Remainder of total byte size of the input data of the NX Unit} \div 32) \\
 &+ (0.34 \times \text{Number of NX Units with BOOL input data} + 3.41) \\
 &+ 3.53 \times \text{Number of NX Units} + 0.014 \times \text{Total byte size of NX Unit input data} + 75.17 \\
 &= 9.22 \times (\text{Integer quotient of 20 bytes} \div 32) + 0.55 \times (\text{Remainder of 20 bytes} \div 32) \\
 &+ (0.34 \times 8 \text{ Units} + 3.41) + 3.53 \times 18 \text{ Units} \\
 &+ 0.014 \times 20 \text{ bytes} + 75.17 \\
 &= 9.22 \times 0.00 + 0.55 \times 20.00 + (0.34 \times 8 \text{ Units} + 3.41) \\
 &+ 3.53 \times 18 \text{ Units} + 0.014 \times 20 \text{ bytes} + 75.17 \\
 &= 156.12
 \end{aligned}$$

(Unit:  $\mu\text{s}$ )

## d. Calculating T#1-OutTrans

The value of T#1-OutTrans is as follows:

$$\begin{aligned}
 \text{Formula: T\#1-Out-} &= 11.71 \times (\text{Integer quotient of total byte size of the output data of the NX Unit} \div 32) \\
 \text{Trans} &+ 0.46 \times (\text{Remainder of total byte size of the output data of the NX Unit} \div 32) \\
 &+ (0.19 \times \text{Number of NX Units with BOOL output data} + 2.93) \\
 &+ (8.10 \times \text{Total number of NX Units with output refreshing with specified time stamps} + 4.49) + 0.38 \times \text{Number of NX Units} + 0.014 \times \text{Total byte size of NX Unit output data} + 30.40 \\
 &= 11.71 \times (\text{Integer quotient of 12 bytes} \div 32) + 0.46 \times (\text{Remainder of 12 bytes} \div 32) \\
 &+ (0.19 \times 8 \text{ Units} + 2.93) + 0 + 0.38 \times 18 \text{ Units} + 0.014 \times 12 \text{ bytes} + 30.40 \\
 &= 11.71 \times 0.00 + 0.46 \times 12.00 + (0.19 \times 8 \text{ Units} + 2.93) \\
 &+ 0 + 0.38 \times 18 \text{ Units} + 0.014 \times 12 \text{ bytes} + 30.40 \\
 &= 47.38
 \end{aligned}$$

(Unit:  $\mu\text{s}$ )

## e. Calculating T#1-Free\_I/OCycle

T#1-exsoft is calculated with the calculation formula for T#1-Free\_I/OCycle.

There are 18 NX Units.

Based on the calculation results for (c) and (d), the values of T#1-InTrans and T#1-OutTrans are as follows:

$$T\#1\text{-InTrans} = 156.12 \mu\text{s}$$

$$T\#1\text{-OutTrans} = 47.38 \mu\text{s}$$

Therefore, the value of T#1-exsoft is as follows:

Formula: T#1-ex-soft	=	$60 + \{0.3 \times \{T\#1\text{-InTrans} + T\#1\text{-OutTrans} + (0.75 \times \text{Number of NX Units}) + 54\}\} \div 0.7$
	=	$60 + \{0.3 \times \{156.12 + 47.38 + (0.75 \times 18 \text{ Units}) + 54\}\} \div 0.7$
	=	176.14

(Unit:  $\mu\text{s}$ )

Therefore, the value of T#1-Free\_I/OCycle is as follows:

Formula: T#n-Free_I/OCycle	=	$T\#n\text{-InTrans} + T\#n\text{-OutTrans} + T\#n\text{-exsoft}$
	=	$156.12 + 47.38 + 176.14$
	=	379.64

(Unit:  $\mu\text{s}$ )

f. Calculating Tnx-InProc

Tnx-InProc of an NX-ID3343 Digital Input Unit is 0  $\mu\text{s}$ .

Therefore the value of Tnx-InProc for the NX-ID3343 Digital Input Unit is as follows:

Formula: Tnx-InProc	=	0.00
---------------------	---	------

(Unit:  $\mu\text{s}$ )

g. Calculating Tnx-OutProc

Tnx-OutProc of an NX-OD3153 Digital Output Unit is 0  $\mu\text{s}$ .

Therefore the value of Tnx-OutProc for the NX-OD3153 Digital Output Unit is as follows:

Formula: Tnx-OutProc	=	0.00
----------------------	---	------

(Unit:  $\mu\text{s}$ )

h. Calculating Tnx-Indelay

Tnx-Indelay of an NX-ID3343 Digital Input Unit is defined as the *ON/OFF response time plus the input filter time*. The ON/OFF response time is 0.10  $\mu\text{s}$  and the input filter time is 0  $\mu\text{s}$ .<sup>\*1</sup>

\*1. Calculation condition (e) says there is *no filter*, so the time is 0  $\mu\text{s}$ .

Therefore the value of Tnx-Indelay for the NX-ID3343 Digital Input Unit is as follows:

Formula: Tnx-Indelay	=	0.10
----------------------	---	------

(Unit:  $\mu\text{s}$ )

i. Calculating Tnx-Outdelay

The Tnx-Outdelay of an NX-OD3153 Digital Output Unit is defined as the *ON/OFF response time*. The ON/OFF response time is 0.30  $\mu\text{s}$ .

Therefore the value of Tnx-Outdelay for the NX-OD3153 Digital Output Unit is as follows:

Formula: Tnx-Outdelay	=	0.30
-----------------------	---	------

(Unit:  $\mu\text{s}$ )

## ● Calculating the I/O Response Times

The I/O response times are as follows based on the calculation results for the elements.

Formula: Maximum I/O response time	$  \begin{aligned}  &= T_{\text{cycle}} \times 2 + E_{\text{delay}} + E_{\text{txj}} + T_{\#1\text{-Free\_I/OCycle}} \times 2 \\  &\quad + T_{\#1\text{-InTrans}} + T_{\#1\text{-OutTrans}} + T_{\text{nx-InProc}} \times 2 \\  &\quad + T_{\text{nx-OutProc}} \times 2 + T_{\text{nx-Indelay}} + T_{\text{nx-Outdelay}} \\  &= 500 \times 2 + 7 + 100 + 379.64 \times 2 + 156.12 + 47.38 \\  &\quad + 0.00 \times 2 + 0.00 \times 2 + 0.10 + 0.30 \\  &= 2070.18  \end{aligned}  $	(Unit: $\mu\text{s}$ )
------------------------------------	---	------------------------

Formula: Minimum I/O response time	$  \begin{aligned}  &= T_{\text{cycle}} + E_{\text{delay}} + E_{\text{txj}} + T_{\#1\text{-InTrans}} + T_{\#1\text{-OutTrans}} \\  &\quad + T_{\text{nx-InProc}} + T_{\text{nx-OutProc}} + T_{\text{nx-Indelay}} \\  &\quad + T_{\text{nx-Outdelay}} \\  &= 500 + 7 + 100 + 156.12 + 47.38 + 0.00 + 0.00 + 0.10 \\  &\quad + 0.30 \\  &= 810.9  \end{aligned}  $	(Unit: $\mu\text{s}$ )
------------------------------------	--	------------------------

## 12-2 Message Response Time

This section describes the minimum message response time for SDO communications and for NX object read/write instructions when an EtherCAT Slave Terminal is connected to the built-in EtherCAT port on an NJ/NX-series CPU Unit or NY-series Industrial PC and I/O refreshing is performed. Refer to the *NX-series Safety Control Unit User's Manual (Cat. No. Z930)* for information on the message response performance when Safety Control Units are connected under the EtherCAT Coupler Unit.

### 12-2-1 Special Instructions

This section describes the instructions that are used to execute message communications.

#### ● Reading and Writing SDO Data

You can read and write SDO data with the following EtherCAT communications instruction to execute SDO communications.

Function name	Instruction	Description
Read EtherCAT CoE SDO	EC_CoESDORead	Sets the parameters and reads data from the object dictionary (SDO data) in the EtherCAT Slave Terminal.
Write EtherCAT CoE SDO	EC_CoESDOWrite	Sets the parameters and writes data to the object dictionary (SDO data) in the EtherCAT Slave Terminal.

#### ● Reading and Writing NX Objects

You can use the following NX object read/write instructions to read and write NX objects.

Function name	Instruction	Description
Read NX Unit Object	NX_ReadObj	Sets the parameters and reads data from the NX objects in the EtherCAT Slave Terminal.
Write NX Unit Object	NX_WriteObj	Sets the parameters and writes data to the NX objects in the EtherCAT Slave Terminal.

### 12-2-2 Minimum Message Response Time

This section describes the minimum message response times of EtherCAT Coupler Units and NX Units on EtherCAT Slave Terminals under the following conditions.

Item	Condition
CPU Unit or Industrial PC periodic task in which I/O is refreshed	Primary periodic task or priority-5 periodic task*1

\*1. The connected CPU Unit or Industrial PC must support a priority-5 periodic task. For example, NX701 CPU Units support them. Refer to *Assignment and Settings Related to Tasks* in the software user's manual for the connected CPU Unit or Industrial PC for information on the periodic tasks that are supported by the CPU Unit or Industrial PC.

The minimum message response time is the time from when the SDO communications instruction or Read NX Unit Object or Write NX Unit Object instruction is executed in the user program until execution of the instruction is completed.

When the instruction is executed in the user program, the EtherCAT master sends a frame to the EtherCAT Coupler Unit or to an NX Unit in the EtherCAT Slave Terminal through the system service. When the EtherCAT Coupler Unit and NX Unit receive the frame, they process the message. When the message processing is completed, the EtherCAT master receives a response from the EtherCAT Slave Terminal to complete execution of the instruction.

The calculations that are described in this section assume that the following conditions are met.

- a. Sequence control and motion control in the NJ/NX-series CPU Unit or NY-series Industrial PC are performed within the task period of the periodic task in which EtherCAT communications were refreshed.
- b. The EtherCAT Coupler Unit is not processing any of the following high-load processes.
  - Multiple message communications
  - Error processing
- c. In DC Mode, the refresh cycle of the NX bus of the EtherCAT Slave Terminal is within the task period of the periodic task.
- d. If you use an NX Unit that has restrictions in the communications cycle in DC Mode, it must be set to a task period for a communications cycle that will satisfy the specifications for the refresh cycles that can be executed by the NX Unit.
- e. If you use an NX Unit that has restrictions in the communications cycle in Free-Run Mode, it must be set to a task period for a communications cycle that will satisfy the specifications for the refresh cycles that can be executed by the NX Unit.

The following sections describe the calculation formulas for the minimum message response time for EtherCAT Slave Terminals for which I/O is refreshed in a periodic task. This is explained for each series of CPU Unit or Industrial PC that connects to EtherCAT Slave Terminals.

## When Connected to the Built-in EtherCAT Port on an NX-series CPU Unit

The calculation formula that is used for the minimum message response time depends on whether the task period of the periodic task is less than 4 ms or is 4 ms or longer.

### ● Calculation Formula When Task Period of Periodic Task Is Less Than 4 ms

Use the following formula to calculate the minimum message response time.

Minimum message response time =	$T_{\text{cycle}} + \{( \text{Rounded up quotient of } (T_{\text{s-resp}} \div T_{\text{cycle}}) )^{*1} \times T_{\text{cycle}}\} + T_{\text{cycle}} + \{( \text{Rounded up quotient of } ( \textit{Message response data byte size} \div \textit{Data byte size to read} ) )^{*2} \times T_{\text{cycle}}\} + T_{\text{cycle}}$
---------------------------------	--

\*1. Round up the value that results from the calculation in parentheses to an integer. It is expressed as follows with a Microsoft Excel function:

ROUNDUP(Ts-resp / Tcycle,0)

\*2. Round up the value that results from the calculation in parentheses to an integer. It is expressed as follows with a Microsoft Excel function:

ROUNDUP(Message\_response\_byte\_size / Data\_byte\_size\_to\_read,0)

- Tcycle: Task period of the periodic task in the CPU Unit
- Ts-resp: Slave message processing time

Calculate the minimum message response times for all EtherCAT Slave Terminals for each periodic task of the CPU Unit that performs I/O refreshing for the EtherCAT Slave Terminals.

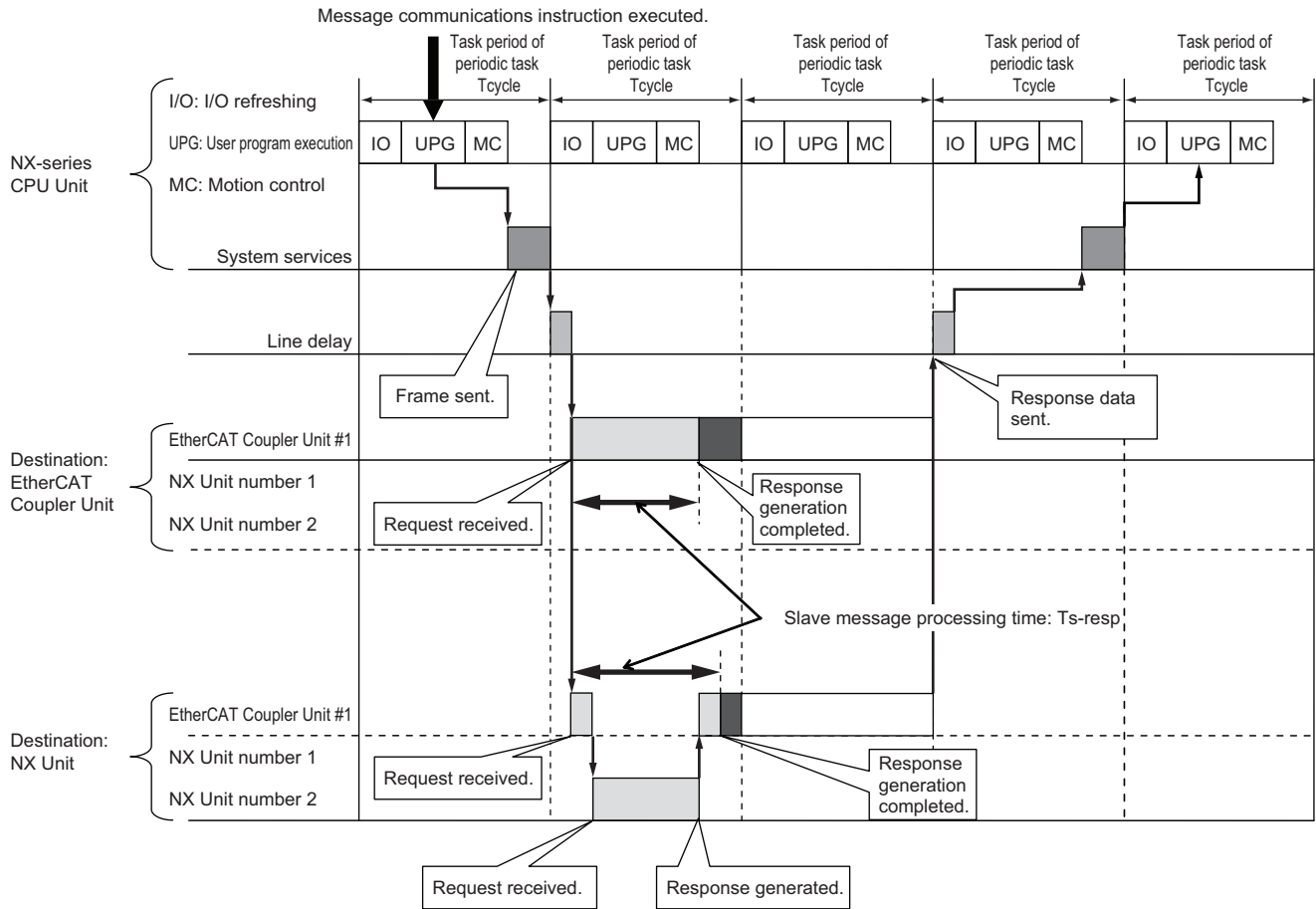

The definitions and values of  $T_{s-resp}$  and the data size to read are given below.

a.  $T_{s-resp}$

$T_{s-resp}$  is the slave message processing time. This is the time from when the message request is received until the EtherCAT Slave Terminal completes generating the response. The minimum values of  $T_{s-resp}$  are given below.

Special Instructions	Message destination	Minimum value of $T_{s-resp}$	
		NX-ECC201 or NX-ECC202	NX-ECC203
Reading and writing of SDO data	EtherCAT Coupler Unit	64.8 [ $\mu$ s]	22.4 [ $\mu$ s]
Reading and writing of NX objects	EtherCAT Coupler Unit	945 [ $\mu$ s]	244 [ $\mu$ s]
	NX Unit	945 [ $\mu$ s]	244 [ $\mu$ s]

b. Data Size to Read

The EtherCAT master reads this size of the message response data from the EtherCAT Slave Terminal in each task period of the periodic task. The size of data to read depends on the set value of the task period of the periodic task as given in the following table.

Value set for the task period of a periodic task	Data size to read
125 $\mu$ s	64 bytes
250 $\mu$ s	128 bytes
500 to 3,750 $\mu$ s*1	256 bytes

\*1. Set in increments of 250  $\mu$ s.

● **Calculation Formula When Task Period of Periodic Task Is 4 ms or Longer**

Use the following formula to calculate the minimum message response time.

$$\text{Minimum message response time} = \text{Divided period} + \{(\text{Rounded up quotient of } (T_{s\text{-resp}} + \text{Divided period}))^{*1} \times \text{Divided period}\} + \text{Divided period} + \{(\text{Rounded up quotient of } (\text{Message response data byte size} \div 256))^{*2} \times \text{Divided period}\} + \text{Divided period}$$

- \*1. Round up the value that results from the calculation in parentheses to an integer. It is expressed as follows with a Microsoft Excel function:  
ROUNDUP(Ts-resp / Divided\_period,0)
- \*2. Round up the value that results from the calculation in parentheses to an integer. It is expressed as follows with a Microsoft Excel function:  
ROUNDUP(Message\_response\_data\_byte\_size / 256,0)

- Divided period: The period that results from dividing the task period of the periodic task.
- Ts-resp: Slave message processing time

Calculate the minimum message response times for all EtherCAT Slave Terminals for each periodic task of the CPU Unit that performs I/O refreshing for the EtherCAT Slave Terminals.

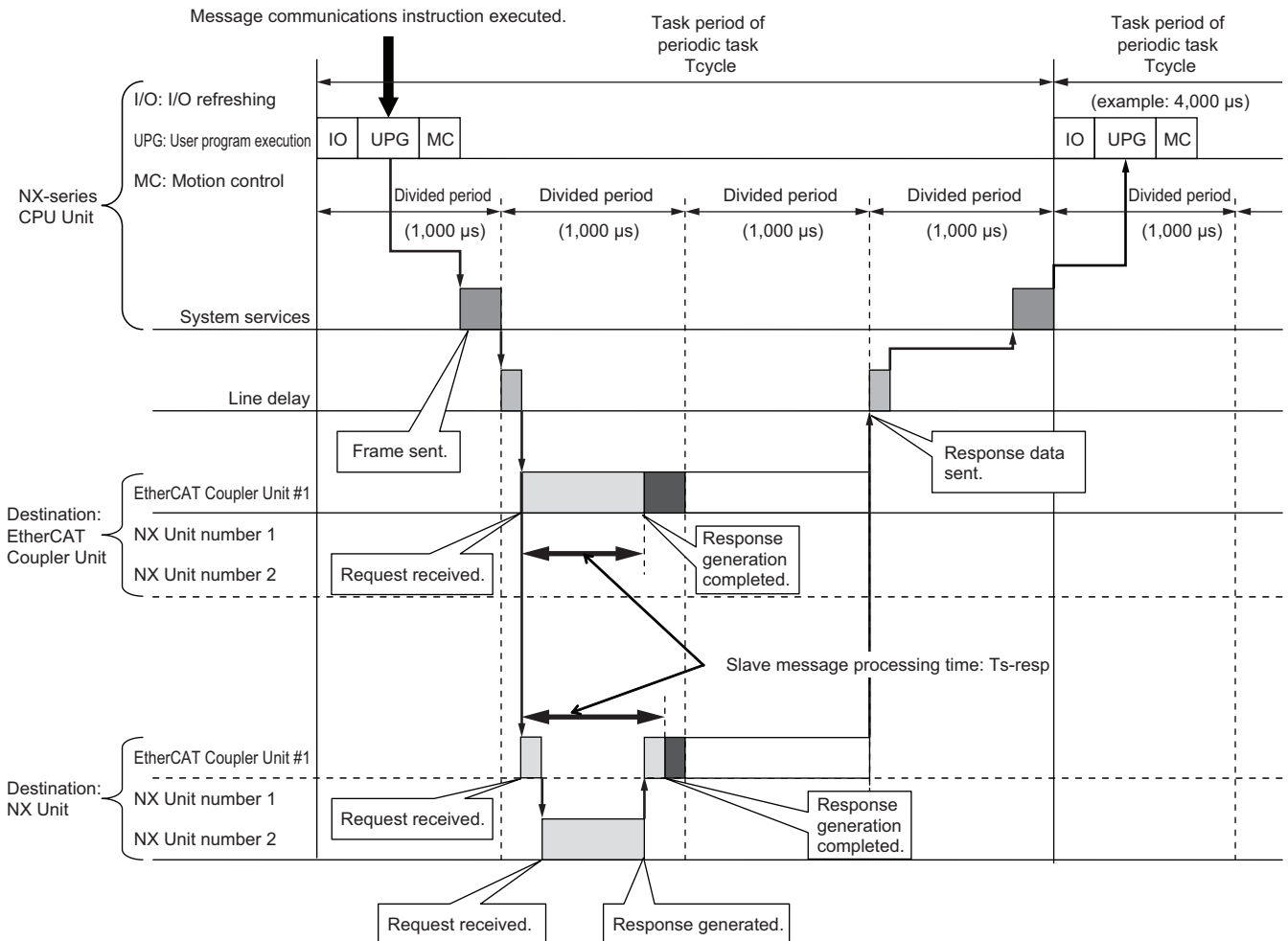

The definitions and values of Ts-resp and the divided period are given below.

a. Ts-resp

The definitions and values of Ts-resp are the same as the definitions and values for the calculation formula for when the task period of the periodic task is less than 4 ms. Refer to *Calculation*

*Formula When Task Period of Periodic Task Is Less Than 4 ms* on page 12-37 under *12-2-2 Minimum Message Response Time* on page 12-36.

b. Divided Period

The period that results from dividing the task period of a periodic task is called the divided period. If the task period of the periodic task is 4 ms or longer, the EtherCAT master sends message communications frames to the EtherCAT slaves and reads message response data from the EtherCAT Slave Terminal according to the divided period.

Use 1,000  $\mu$ s as the divided period in calculations.

## When Connected to the Built-in EtherCAT Port on an NJ-series CPU Unit

Use the following formula to calculate the minimum message response time.

Minimum message response time =	$T_{\text{cycle}} + \{(\text{Rounded up quotient of } (T_{\text{s-resp}} \div T_{\text{cycle}}))^{*1} \times T_{\text{cycle}}\} + T_{\text{cycle}} + \{(\text{Rounded up quotient of } (\text{Message response data byte size} \div 256))^{*2} \times T_{\text{cycle}}\} + T_{\text{cycle}}$
---------------------------------	--

\*1. Round up the value that results from the calculation in parentheses to an integer. It is expressed as follows with a Microsoft Excel function:

`ROUNDUP(Ts-resp / Tcycle,0)`

\*2. Round up the value that results from the calculation in parentheses to an integer. It is expressed as follows with a Microsoft Excel function:

`ROUNDUP(Message_response_data_byte_size / 256,0)`

- Tcycle: Task period of the primary periodic task in the CPU Unit
- Ts-resp: Slave message processing time

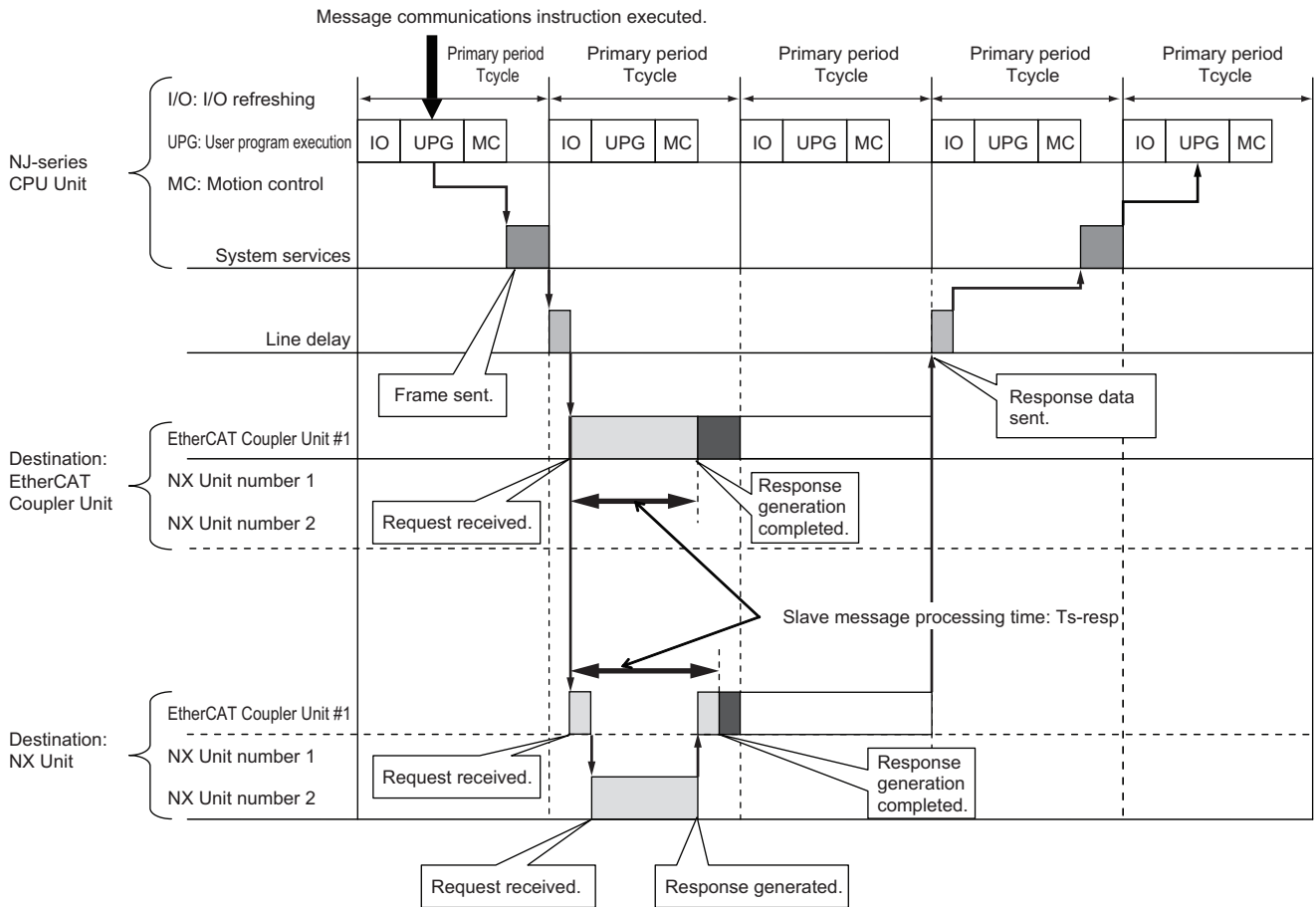

The definitions and values of  $T_{s-resp}$  are the same as the definitions and values for the calculation formula when connected to the built-in EtherCAT port on an NX-series CPU Unit. Refer to *Calculation Formula When Task Period of Periodic Task Is Less Than 4 ms* on page 12-37 under *12-2-2 Minimum Message Response Time* on page 12-36 for the definitions and values of  $T_{s-resp}$ .

## When Connected to a Built-in EtherCAT Port on an NY-series Industrial PC

The minimum message response time is calculated using the same formula as is used for a connection to the built-in EtherCAT port on an NX-series CPU Unit. Refer to *When Connected to the Built-in EtherCAT Port on an NX-series CPU Unit* on page 12-37 for the formulas. The periodic tasks in which I/O is refreshed and the task periods that can be set for the period tasks are different here from when the Slave Terminal is connected to the built-in EtherCAT port on an NX-series CPU Unit. Be careful to use the correct values in the calculations. Refer to *10-3-4 I/O Refreshing Method Operation* on page 10-10 for the periodic tasks in which Slave Terminal I/O can be refreshed. For information on the task periods of the periodic tasks that you can set for NY-series Industrial PCs, refer to *Specifications of Tasks* in the *NY-series IPC Machine Controller Industrial Panel PC / Industrial Box PC Software User's Manual (Cat. No. W558)*.



# 13

## Troubleshooting

There are several ways to check errors on an EtherCAT Slave Terminal. If an error occurs, refer to this section to troubleshoot the error.

13

<b>13-1</b>	<b>How to Check for Errors .....</b>	<b>13-2</b>
<b>13-2</b>	<b>Checking for Errors and Troubleshooting with the Indicators .....</b>	<b>13-3</b>
13-2-1	Checking for Errors and Troubleshooting with the Indicators on the EtherCAT Coupler Unit.....	13-3
13-2-2	Checking for Errors and Troubleshooting with the Indicators on the NX Units .....	13-11
<b>13-3</b>	<b>Checking for Errors and Troubleshooting on the Sysmac Studio .....</b>	<b>13-12</b>
13-3-1	Checking for Errors from the Sysmac Studio .....	13-12
13-3-2	Event Codes for Errors and Troubleshooting Procedures.....	13-14
<b>13-4</b>	<b>Resetting Errors .....</b>	<b>13-53</b>
<b>13-5</b>	<b>Error Notification Methods .....</b>	<b>13-54</b>
<b>13-6</b>	<b>Error Notifications Based on the Sysmac Error Status.....</b>	<b>13-55</b>
<b>13-7</b>	<b>Emergency Messages.....</b>	<b>13-56</b>
13-7-1	Enabling/Disabling Emergency Message Notification .....	13-56
13-7-2	Error Logs.....	13-56
13-7-3	Emergency Error Codes .....	13-57
<b>13-8</b>	<b>Error Notifications Based on the AL Status .....</b>	<b>13-60</b>
13-8-1	Procedure for Checking AL Status Codes.....	13-60
13-8-2	AL Status Codes .....	13-60
<b>13-9</b>	<b>Troubleshooting Other Errors.....</b>	<b>13-64</b>
<b>13-10</b>	<b>Troubleshooting Flow When Errors Occur .....</b>	<b>13-65</b>
13-10-1	When the Sysmac Studio Is Connected to a CPU Unit or an Industrial PC .....	13-65
13-10-2	When the Sysmac Studio Is Connected to the EtherCAT Coupler Unit .....	13-66
<b>13-11</b>	<b>Troubleshooting When the Sysmac Studio Cannot Go Online.....</b>	<b>13-68</b>
13-11-1	Causes and Corrective Actions When the Sysmac Studio Cannot Go Online.....	13-68
13-11-2	Troubleshooting by Cause.....	13-69

## 13-1 How to Check for Errors

Use the following methods to check the status of errors on the EtherCAT Slave Terminal.

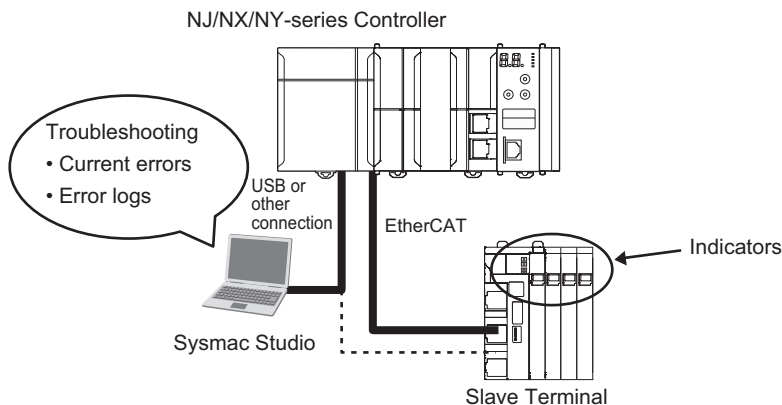

Checking method	What you can check
Checking the indicators	The indicators tell you the status of each Unit, and the level of the error.
Troubleshooting with the Sysmac Studio	You can check for current Controller errors, a log of past Controller errors, error sources, error causes, and corrections.

If you use an NJ/NX/NY-series Controller, refer to the troubleshooting manual for the connected CPU Unit or Industrial PC for the procedures to check for errors in the entire Controller.



### Precautions for Correct Use

If an error occurs where the controller cannot communicate with the EtherCAT Coupler Unit such as a State Transition Impossible (AL status: 0001 hex), the Sysmac Studio connected to the controller will not be able to detect the error of the EtherCAT Coupler Unit. In that case, please connect Sysmac Studio directly to the EtherCAT Coupler Unit.



### Additional Information

Refer to the appendices of the troubleshooting manual for the connected CPU Unit or Industrial PC for the specifications for checking EtherCAT Slave Terminal errors on an OMRON HMI.

## 13-2 Checking for Errors and Troubleshooting with the Indicators

You can check for errors in the EtherCAT Slave Terminal with the indicators on the EtherCAT Coupler Unit and the NX Units. This section tells you about the errors that the indicators show and the troubleshooting procedures for them.

### 13-2-1 Checking for Errors and Troubleshooting with the Indicators on the EtherCAT Coupler Unit

#### Indicators

Name	Function
L/A IN	The L/A IN indicator shows the status of the inputs in EtherCAT communications.
L/A OUT	The L/A OUT indicator shows the status of the outputs in EtherCAT communications.
RUN	The RUN indicator shows the operating status of EtherCAT communications for the EtherCAT Coupler Unit.
ERR	The ERR indicator provides information on errors in the EtherCAT Coupler Unit.
TS	The TS indicator gives the status of the EtherCAT Coupler Unit and the communications status between the EtherCAT Coupler Unit and the NX Units.
UNIT PWR	The UNIT PWR indicator shows the status of the Unit power supply.
IO PWR	The IO PWR indicator shows the status of the I/O power supply.

#### Primary Errors That the Indicators Show and Troubleshooting Procedures

Here, the following abbreviations are used to describe the status of the indicators.

Abbreviation	Indicator status
Lit	Lit.
Not Lit	Not lit.
FS ()	A flashing pattern other than flickering, blinking, single flash, and double flash. The numeric value in parenthesis is the interval.
FK	Flickering
B	Blinking
SF	Single flash
DF	Double flash
---	Undefined.

The timing of indicator flashing is given below.

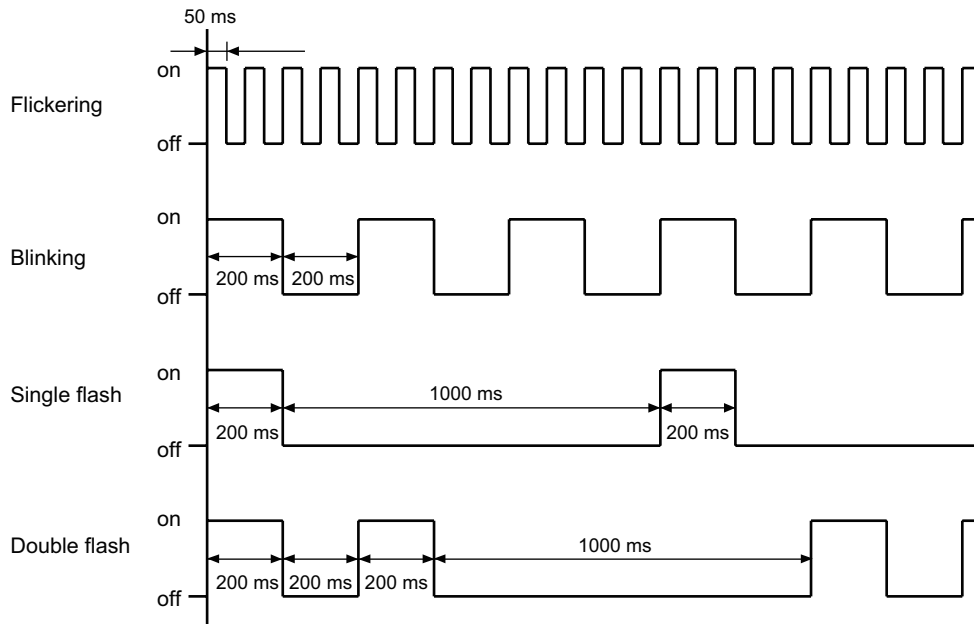

● Troubleshooting the Primary Errors That Are Displayed with the UNIT PWR, L/A IN, L/A OUT, ERR, and TS Indicators

UNIT PWR [green ]	L/A IN L/A OUT [green]	RUN [green ]	ERR [red]	TS		Cause	Corrective action
				Green	Red		
Lit	FK	Lit	Not Lit	Lit	Not Lit	---	--- (This is the normal status.)
Not Lit	Not Lit	Not Lit	Not Lit	Not Lit	Not Lit	No power is supplied by the Unit power supply.	Check the following items and make sure that power is correctly supplied from the Unit power supply. Checks Related to the Power Supply <ul style="list-style-type: none"> <li>• Make sure that the power supply cable is wired properly.</li> <li>• Make sure that there are no breaks in the power supply cable.</li> <li>• Make sure that the power supply voltage is within the specified range.</li> <li>• Make sure that the power supply has enough capacity.</li> <li>• Make sure that the power supply has not failed.</li> </ul>
Lit	---	Not Lit	Lit	Not Lit	Lit	Hardware failure	If cycling the power supply to the EtherCAT Slave Terminal does not clear the error, replace the EtherCAT Coupler Unit.

UNIT PWR [green ]	L/A IN L/A OUT [green]	RUN [green ]	ERR [red]	TS		Cause	Corrective action
				Green	Red		
Lit	---	Not Lit	Not Lit	Not Lit	Not Lit	Node address setting errors (the TS indicator on the NX Unit is also not lit).	Set the node address correctly. <ul style="list-style-type: none"> <li>The same node address is also used for another slave.</li> <li>The node address is out of the setting range for the EtherCAT master. For the node address setting range for the EtherCAT Coupler Unit, refer to 3-1-2 <i>EtherCAT Coupler Unit Specifications</i> on page 3-2.</li> </ul>
						If you cannot resolve the problem after you check the above items and cycle the Unit power supply, the EtherCAT Coupler Unit may have a hardware failure. Replace the EtherCAT Coupler Unit.	
Lit	---	Not Lit	FK	Not Lit	Lit	ESC Error	If cycling the power supply to the EtherCAT Slave Terminal does not clear the error, replace the EtherCAT Coupler Unit.
Lit	---	---	B	Not Lit	FS (1s)	NX Unit Communications Timeout	Check the following items. <ul style="list-style-type: none"> <li>Make sure that the NX Unit is mounted correctly.</li> </ul> If the error occurs again even after you make the above correction, replace the NX Unit.
Lit	---					NX Unit Initialization Error	Connect the Sysmac Studio, and then set and save the Unit configuration information in the Communications Coupler Unit again. If this error occurs again, check that there are no errors in the NX Unit settings and I/O data mapping information, and correct any errors that are found. <p>For an Analog I/O Unit, set the Channel Enable/Disable Setting to <i>Enable</i> for at least one channel.</p> If the error occurs again even after you check the items above, cycle the power supply to the NX Unit in question. If this error persists, replace the NX Unit.
Lit	---	---	B	Not Lit	Lit	Bus Controller Error	Mount the NX Units and End Cover securely and secure them with End Plates.
						Non-volatile Memory Control Parameter Error	If you turn OFF the power supply to the NX Unit or disconnect the Sysmac Studio communications while writing the control parameters is in progress, write the control parameters again.

UNIT PWR [green ]	L/A IN L/A OUT [green]	RUN [green ]	ERR [red]	TS		Cause	Corrective action
				Green	Red		
						Memory Corruption De- tected	Cycle the power supply to the Ether- CAT Slave Terminal. If this error oc- curs again even after you cycle the power supply, replace the EtherCAT Coupler Unit.
						Unit Configuration Error, Too Many Units	Make sure that the number of NX Units that are connected does not ex- ceed the upper limit of the specifica- tions.
						Unit Configuration Error, Unsupported Configura- tion	Make sure that the total byte size of all I/O data in the EtherCAT Slave Termi- nal does not exceed the upper size limit of 1,024 bytes for input data or 1,024 bytes for output data.
						Unit Configuration Infor- mation Error	If you turn OFF the power supply to the EtherCAT Coupler Unit or discon- nect communications with the Sysmac Studio while a download of Unit con- figuration information is in progress, clear all memory on the EtherCAT Coupler Unit, and then download the Unit configuration information again.
						Unit Configuration Verifi- cation Error	There is an inconsistency between the Unit configuration information in the EtherCAT Coupler Unit and the Units that are actually connected. <ul style="list-style-type: none"> <li>• Make sure that the Unit that is con- nected is registered.</li> <li>• Make sure that the Unit that is reg- istered is connected.</li> </ul>
		Not Lit				Slave Unit Verification Error	Cycle the power supply to the Ether- CAT Slave Terminal. If this error oc- curs again even after you cycle the power supply, replace the EtherCAT Coupler Unit.
		---				NX Unit Startup Error	Cycle the power supply to the Ether- CAT Slave Terminal. If this error oc- curs again even after you cycle the power supply, replace the NX Unit.
						Check the items described above. If this error occurs again even after you cycle the power supply, replace the EtherCAT Coupler Unit.	

UNIT PWR [green ]	L/A IN L/A OUT [green]	RUN [green ]	ERR [red]	TS		Cause	Corrective action
				Green	Red		
Lit	---	B	B	---	FS (1 s)	Mailbox Setting Error	<p>When the master from another manufacturer is connected Correct the mailbox setting and then download the settings to the EtherCAT master again. If the error occurs again even after you make the above correction, replace the relevant EtherCAT Coupler Unit.</p> <p>When the NJ/NX-series CPU Unit or NY-series Industrial PC is connected Cycle the power supply to the NJ/NX-series CPU Unit or NY-series Industrial PC. Then, cycle the power supply to the EtherCAT Coupler Unit. If this error occurs again even after you make the above correction, replace the relevant CPU Unit, Industrial PC, or EtherCAT Coupler Unit.</p>
		---	<ul style="list-style-type: none"> <li>• RxPDO Setting Error</li> <li>• TxPDO Setting Error</li> <li>• PDO WDT Setting Error</li> <li>• SM Event Mode Setting Error</li> <li>• TxPDO Mapping Error</li> <li>• RxPDO Mapping Error</li> </ul>			Correct the setting and then download the settings to the EtherCAT master again.	
		B	<ul style="list-style-type: none"> <li>• Illegal State Transition Request Received</li> <li>• Error State Transition Received</li> </ul>			Change states correctly according to EtherCAT specifications.	
						Synchronization Cycle Setting Error	Correct the setting and then download the settings to the EtherCAT master again.

UNIT PWR [green ]	L/A IN L/A OUT [green]	RUN [green ]	ERR [red]	TS		Cause	Corrective action
				Green	Red		
Lit	---	SF	SF	Not Lit	FS (1 s)	Synchronization Inter- ruption Error	<p>Check the following items, and then reset the error in the EtherCAT Coupler Unit.</p> <p>Items Related to the Communications Cable</p> <ul style="list-style-type: none"> <li>• Make sure that the communications cable is wired properly.</li> <li>• Make sure that there are no breaks in the communications cable or loosening in the mating parts.</li> <li>• Make sure that the cable is of the appropriate length.</li> <li>• Make sure that the communications cable meets the recommended specifications.</li> </ul> <p>Items Related to the Synchronization Settings</p> <ul style="list-style-type: none"> <li>• Make sure that the synchronization settings for the EtherCAT Coupler Unit are equal or longer than the minimum time for synchronizing the EtherCAT Coupler Unit.</li> </ul> <p>If the error occurs again even after you make the above correction, the Communications Coupler Unit may have a hardware failure. In that case, replace the EtherCAT Coupler Unit.</p>
						Synchronization Error	Same as above.
						Communications Syn- chronization Error	<p>Check the following items, and then reset the error in the EtherCAT Coupler Unit. If the power to the host EtherCAT master was interrupted, reset the error in the Controller.</p> <p>Items Related to the Communications Cable</p> <ul style="list-style-type: none"> <li>• Make sure that the communications cable is wired properly.</li> <li>• Make sure that there are no breaks in the communications cable or loosening in the mating parts.</li> <li>• Make sure that the cable is of the appropriate length.</li> <li>• Make sure that the communications cable meets the recommended specifications.</li> </ul> <p>Items Related to the Host EtherCAT Master</p> <ul style="list-style-type: none"> <li>• Check if there was a power interruption during process data communications with the host EtherCAT master.</li> </ul>

UNIT PWR [green ]	L/A IN L/A OUT [green]	RUN [green ]	ERR [red]	TS		Cause	Corrective action
				Green	Red		
Lit	---	SF	DF	Not Lit	FS (1 s)	Process Data WDT Error	<p>Check the following items, and then reset the error in the EtherCAT Coupler Unit. Check the host EtherCAT master for problems and take the appropriate measures.</p> <p>Items Related to the Communications Cable</p> <ul style="list-style-type: none"> <li>• Make sure that the communications cable is wired properly.</li> <li>• Make sure that there are no breaks in the communications cable or loosening in the mating parts.</li> <li>• Make sure that the cable is of the appropriate length.</li> <li>• Make sure that the communications cable meets the recommended specifications.</li> </ul> <p>Items Related to the Host EtherCAT Master</p> <ul style="list-style-type: none"> <li>• Make sure that the host EtherCAT master does not have operational errors.</li> </ul>
Lit	Lit	---	---	---	---	A link was established in the physical layer.	--- (The Coupler Unit is in standby status after the link was established in the physical layer. Wait until processing is completed.)
Lit	Not Lit	---	---	---	---	A link was not established in the physical layer.	<p>Check the following items, and then restart the Slave Terminal based on the specifications of the connected EtherCAT master.</p> <p>Items Related to the Communications Cable</p> <ul style="list-style-type: none"> <li>• Make sure that the communications cable is wired properly.</li> <li>• Make sure that there are no breaks in the communications cable or loosening in the mating parts.</li> <li>• Make sure that the cable is of the appropriate length.</li> <li>• Make sure that the communications cable meets the recommended specifications.</li> </ul>
						The host master is not operating.	Make sure that the operation of the EtherCAT master is correct.
						If you cannot resolve the problem after you check the above items and cycle the Unit power supply, there may be a hardware failure. In that case, replace the EtherCAT Coupler Unit.	
Lit	---	---	---	FS (2 s)	Not Lit	Initializing	--- (This status is normal. Wait until processing is completed.)

UNIT PWR [green ]	L/A IN L/A OUT [green]	RUN [green ]	ERR [red]	TS		Cause	Corrective action
				Green	Red		
Lit	---	---	---	FS (0.5 s)	Not Lit	Unit configuration information is not set. The EtherCAT Coupler Unit is operating according to the actual Unit configuration.	Promptly check whether the configuration is the intended configuration, and then register the Unit configuration information on the Sysmac Studio.

### ● I/O PWR Indicator

Color	Status	Meaning	Cause	Corrective action
Green	Lit	Power is currently supplied from the I/O power supply.	---	---- (This is the normal status.)
	Not Lit	No power is currently supplied.	There is no I/O power supply.	Check the following items and make sure that power is correctly supplied from the I/O power supply. Checks Related to the Power Supply <ul style="list-style-type: none"> <li>• Make sure that the power supply cable is wired properly.</li> <li>• Make sure that there are no breaks in the power supply cable.</li> <li>• Make sure that the power supply voltage is within the specified range.</li> <li>• Make sure that the power supply has enough capacity.</li> <li>• Make sure that the power supply has not failed.</li> </ul>

## 13-2-2 Checking for Errors and Troubleshooting with the Indicators on the NX Units

The TS indicator on an NX Unit tells you the status and level of any errors in the NX Unit.

For details on the other indicators on the NX Units, refer to *Checking for Errors with the Indicators* in the user's manuals for the NX Units.

## 13-3 Checking for Errors and Troubleshooting on the Sysmac Studio

Error management on the NX-series is based on the methods used for the NJ/NX/NY-series Controllers.

This allows you to use the Sysmac Studio to check the meanings of errors and troubleshooting procedures.

### 13-3-1 Checking for Errors from the Sysmac Studio

When an error occurs, you can place the Sysmac Studio online to the Controller or the EtherCAT Coupler Unit to check current Controller errors and the log of past Controller errors.

The methods that are used to check errors depend on the Controller you use.

Controller used	Sysmac Studio connection	Scope of check	Remarks
NJ/NX/NY-series Controller	NJ/NX-series CPU Unit or NY-series Industrial PC	You can check the errors that are managed by the Controller. This includes errors for the connected EtherCAT Slave Terminals.	<ul style="list-style-type: none"> <li>You cannot check errors if there is a <i>fatal error in the CPU Unit or Industrial PC</i>.</li> <li>You cannot check errors if there is a <i>fatal error in the EtherCAT Coupler Unit</i>.</li> <li>Some errors in the NX Units cannot be checked if a <i>fatal error occurs in that NX Unit</i>.<sup>*1</sup></li> </ul>
	EtherCAT Coupler Unit	You can check the errors that are managed by the EtherCAT Coupler Unit. You can check errors in the EtherCAT Coupler Unit to which the Sysmac Studio is connected, and errors in the NX Units that are connected after the EtherCAT Coupler Unit.	<ul style="list-style-type: none"> <li>You can check errors in the Slave Terminals even if there is a <i>fatal error in the CPU Unit or Industrial PC</i>.</li> <li>You cannot check errors if there is a <i>fatal error in the EtherCAT Coupler Unit</i>.</li> <li>Some errors in the NX Units cannot be checked if a <i>fatal error occurs in that NX Unit</i>.<sup>*1</sup></li> </ul>
Other controllers	EtherCAT Coupler Unit	Same as above.	Same as above.

\*1. On NX Units that manage their own errors, current errors cannot be checked after a *fatal error occurs in that NX Unit*. On NX Units that record their own event logs, the error log cannot be checked after a *fatal error occurs in that NX Unit*.

Refer to the troubleshooting manual for the connected CPU Unit or Industrial PC for information on NJ/NX/NY-series error management methods.

Refer to the *Sysmac Studio Version 1 Operation Manual (Cat. No. W504)* for details on troubleshooting with the Sysmac Studio.

If you cannot check the error on the Sysmac Studio, check the error by following the flow outlined in *13-10 Troubleshooting Flow When Errors Occur* on page 13-65.



### Additional Information

Refer to the appendices of the troubleshooting manual for the connected CPU Unit or Industrial PC for the specifications for checking EtherCAT Slave Terminal errors on an OMRON HMI.

## Current Errors

Open the Sysmac Studio's **Controller Error** Tab Page to check the current *error's level, source, source details, event name, event codes, details, attached information 1 to 4, and correction*. Errors in the *observation level* are not displayed.



### Additional Information

#### Number of Current Errors

The following table gives the number of errors that are reported simultaneously as current errors in each Unit.

Unit	Number of simultaneous error notifications
EtherCAT Coupler Unit	128 errors
NX Units	<p>For NX Units that manage their own current errors, the number of current errors depends on the specifications of the individual Units.</p> <p>For NX Units that do not manage their own current errors, current errors are managed in the EtherCAT Coupler Unit, so the number of current errors is limited by the number of errors for the EtherCAT Coupler Unit.</p> <p>Refer to the manual for each NX Unit to find out if the NX Unit manages its own current errors.</p>

If the number of errors exceeds the maximum number of reportable current errors, errors are reported with a priority given to the oldest and highest-level errors. Errors that exceed the limit on simultaneous error notifications are not reported. Errors that are not reported are still reflected in the error status.

## Log of Past Errors

Open the Sysmac Studio's **Controller Event Log** Tab Page to check the *times, levels, sources, source details, event names, event codes, details, attached information 1 to 4, and corrections for previous errors*.

Refer to the troubleshooting manual for the connected CPU Unit or Industrial PC and the *Sysmac Studio Version 1 Operation Manual (Cat. No. W504)* for the items that you can check and the procedures to check for errors. Refer to *11-5 Event Logs* on page 11-15 for details on the event log in the Slave Terminal.

Refer to *13-3-2 Event Codes for Errors and Troubleshooting Procedures* on page 13-14 for details on event codes.

### ● Error Notifications for Slave Terminals

The NJ/NX/NY-series Controller can use the Sysmac error status to detect errors that occur in an EtherCAT Slave Terminal. Refer to *13-6 Error Notifications Based on the Sysmac Error Status* on page 13-55 for details on the Sysmac error status.

## 13-3-2 Event Codes for Errors and Troubleshooting Procedures

This section describes the errors (events) that can occur and how to troubleshoot them.

### Error Table

The errors (i.e., events) that can occur in the EtherCAT Coupler Unit are given on the following pages. The following abbreviations are used in the Level column.

Abbreviation	Meaning
Maj	Major fault level
Prt	Partial fault level
Min	Minor fault level
Obs	Observation level
Info	Information level

A version in parentheses in the Event code column is the model or unit version of the EtherCAT Coupler Unit when the event occurs for only specific models or unit versions of the EtherCAT Coupler Unit.

Refer to the troubleshooting manual for the connected CPU Unit or Industrial PC for information on NJ/NX/NY-series event codes.

Event code	Event name	Meaning	Assumed cause	Level					Reference
				Maj	Prt	Min	Obs	Info	
00210000 hex	Bus Controller Error	An internal bus error occurred.	<ul style="list-style-type: none"> <li>A Unit failed or an I/O communications error occurred between the Communications Coupler Unit and the NX Unit.</li> </ul>			○			page 13-22
00220000 hex	Non-volatile Memory Hardware Error	An error occurred in non-volatile memory.	<ul style="list-style-type: none"> <li>Non-volatile memory failure</li> </ul>			○			page 13-23
05010000 hex	ESC Error	An error occurred in the EtherCAT slave communications controller.	<ul style="list-style-type: none"> <li>An error occurred in the EtherCAT slave communications controller.</li> </ul>			○			page 13-24
05020000 hex	ESC Initialization Error	Initialization of the EtherCAT slave communications controller failed.	<ul style="list-style-type: none"> <li>An initialization error occurred in the EtherCAT slave communications controller.</li> </ul>			○			page 13-25
05030000 hex	Slave Unit Verification Error	An error occurred in Slave Unit verification.	<ul style="list-style-type: none"> <li>An error occurred in Slave Unit information.</li> </ul>			○			page 13-26

Event code	Event name	Meaning	Assumed cause	Level					Reference
				Maj	Prt	Min	Obs	In-fo	
10420000 hex	Non-volatile Memory Control Parameter Error	An error occurred in the control parameters.	<ul style="list-style-type: none"> <li>The power supply to the Communications Coupler Unit was turned OFF or Support Software communications were disconnected while writing the Unit operation settings was in progress.</li> </ul>			○			page 13-27
10430000 hex	Memory Corruption Detected	Memory corruption was detected.	<ul style="list-style-type: none"> <li>Memory corruption was detected.</li> </ul>			○			page 13-28
24A00000 hex	Unit Configuration Error, Too Many Units	The number of connected NX Units exceeds the maximum value for the Communications Coupler Unit.	<ul style="list-style-type: none"> <li>More than the maximum number of NX Units is connected to the Communications Coupler Unit.</li> </ul>			○			page 13-29
24A10000 hex	Unit Configuration Error, Unsupported Configuration	An unsupported NX Unit is mounted. Or, the total byte size of all I/O data for the connected NX Units exceeds the predetermined maximum value for the Communications Coupler Unit.	<ul style="list-style-type: none"> <li>An unsupported NX Unit was detected.</li> <li>The total byte size of all I/O data for the connected NX Units exceeds the predetermined maximum value for the Communications Coupler Unit.</li> </ul>			○			page 13-30
35000000 hex	Unit Configuration Information Error	An error occurred in the Unit configuration information in the Communications Coupler Unit.	<ul style="list-style-type: none"> <li>The power supply to the Communications Coupler Unit was turned OFF or Support Software communications were disconnected while downloading the Unit configuration information.</li> </ul>			○			page 13-31

Event code	Event name	Meaning	Assumed cause	Level					Reference
				Maj	Prt	Min	Obs	In-fo	
35010000 hex	Unit Configuration Verification Error	There is an inconsistency between the Unit configuration information in the Communications Coupler Unit and the Units that are actually connected. Or, the Unit configuration was changed during operation while the Unit configuration information was not set in the Communications Coupler Unit.	<ul style="list-style-type: none"> <li>An NX Unit that is registered in the Unit configuration information is not connected.</li> <li>A connected NX Unit does not agree with the NX Unit that is registered in the Unit configuration information.</li> <li>An NX Unit that is not registered in the Unit configuration information is connected.</li> <li>A mounted Unit is disabled in the NX Unit Mounting Setting for the Unit configuration information.</li> <li>An NX Unit became disconnected during operation.</li> <li>An NX Unit was connected during operation.</li> <li>The serial number of a Unit that is registered in the Unit configuration information does not agree with the serial number of the Unit that is connected. (The Serial Number Check Method is set to <i>Setting = Actual device</i>.)</li> <li>The version of a Unit that is registered in the Unit configuration information is newer than the version of the Unit that is connected.</li> <li>The power supply to an Additional NX Unit Power Supply Unit is not turned ON.</li> </ul>			○			page 13-32
35020000 hex	NX Unit Minor Fault	A minor fault was detected in an NX Unit.	<ul style="list-style-type: none"> <li>A minor fault level error occurred in a Unit where an error was detected.</li> </ul>			○			page 13-34
35040000 hex	Mailbox Setting Error	An incorrect mailbox setting was detected for the Sync Manager. (AL-Status Code: 0016 hex)	<ul style="list-style-type: none"> <li>An incorrect mailbox setting was detected for the Sync Manager.</li> </ul>			○			page 13-35

Event code	Event name	Meaning	Assumed cause	Level					Reference
				Maj	Prt	Min	Obs	Info	
35050000 hex	RxPDO Setting Error	An error was detected in the RxPDO settings. (AL-Status Code: 001D hex)	• An error was detected in the RxPDO settings.			○			page 13-36
35060000 hex	TxPDO Setting Error	An error was detected in the TxPDO settings. (AL-Status Code: 001E hex)	• An error was detected in the TxPDO settings.			○			page 13-36
35070000 hex	PDO WDT Setting Error	An incorrect PDO WDT setting was detected. (AL-Status Code: 001F hex)	• An incorrect PDO WDT setting was detected.			○			page 13-37
35080000 hex	SM Event Mode Setting Error	An SM Event Mode that is not supported was set. (AL-Status Code: 0028 hex)	• An SM Event Mode that is not supported was set.			○			page 13-37
35090000 hex	TxPDO Mapping Error	An incorrect TxPDO was set. (AL-Status Code: 0024 hex)	• An incorrect TxPDO was set, e.g., the index, subindex, or size was outside of the allowable range.			○			page 13-38
350A0000 hex	RxPDO Mapping Error	An incorrect RxPDO was set. (AL-Status Code: 0025 hex)	• An incorrect RxPDO was set, e.g., the index, subindex, or size was outside of the allowable range.			○			page 13-38
350B0000 hex	Illegal State Transition Request Received	An incorrect state transition request was received. (AL-Status Code: 0011 hex)	• An incorrect state transition request was received.			○			page 13-39
350C0000 hex	Error State Transition Received	An unclear state transition request was received. (AL-Status Code: 0012 hex)	• An unclear state transition request was received.			○			page 13-40
350D0000 hex	Synchronization Cycle Setting Error	When DC Mode was confirmed, the cycle time was set to a value that made operation impossible. (AL-Status Code: 0035 hex)	• When DC Mode was confirmed, the cycle time was set to a value that made operation impossible.			○			page 13-40
40200000 hex	NX Unit Processing Error	A fatal error occurred in an NX Unit.	• An error occurred in the software.			○			page 13-41
84C00000 hex	NX Unit Communications Timeout	An error occurred in I/O data communications with the NX Units.	• An NX Unit is not mounted properly. • An NX Unit has failed.			○			page 13-42

Event code	Event name	Meaning	Assumed cause	Level					Reference
				Maj	Prt	Min	Obs	In-fo	
84C10000 hex	NX Unit Initialization Error	Initializing an NX Unit failed.	<ul style="list-style-type: none"> <li>An error occurred in processing the Communications Coupler Unit.</li> <li>An initialization error occurred in an NX Unit.</li> <li>The Channel Enable/Disable Setting for all channels of the Analog Input Unit are set to <i>Disable</i>. The Channel Enable/Disable Setting for all channels of the Analog Output Unit are set to <i>Disable</i>.</li> </ul>			○			page 13-43
85000000 hex	Process Data WDT Error	Process data communications were stopped for more than the specified period of time.	<ul style="list-style-type: none"> <li>The EtherCAT communications cable is disconnected or broken.</li> <li>There is an error in the host controller.</li> </ul>			○			page 13-44
85010000 hex	Synchronization Interruption Error	A synchronization interruption error occurred.	<ul style="list-style-type: none"> <li>The EtherCAT communications cable is disconnected or broken.</li> <li>There is a synchronization setting error in the EtherCAT Coupler Unit.</li> <li>There is a hardware error in the EtherCAT Coupler Unit.</li> </ul>			○			page 13-45
85020000 hex	Synchronization Error	A synchronization error occurred.	<ul style="list-style-type: none"> <li>The EtherCAT communications cable is disconnected or broken.</li> <li>There is a synchronization setting error in the EtherCAT master or EtherCAT Coupler Unit.</li> <li>There is a hardware error in the EtherCAT Coupler Unit.</li> </ul>			○			page 13-46
85030000 hex	Communications Synchronization Error	The number of consecutive communications errors in receiving the synchronization data exceeded the value that is set for the Consecutive Communications Error Detection Count parameter in the Communications Error Settings.	<ul style="list-style-type: none"> <li>Power to the host controller was interrupted during process data communications.</li> <li>The EtherCAT communications cable is disconnected or broken.</li> <li>Noise is entering on an EtherCAT communications cable.</li> </ul>			○			page 13-47
84C50000 hex	NX Unit Startup Error	Starting an NX Unit failed.	<ul style="list-style-type: none"> <li>A startup error occurred in an NX Unit.</li> </ul>			○			page 13-48

Event code	Event name	Meaning	Assumed cause	Level					Reference
				Maj	Prt	Min	Obs	In-fo	
35030000 hex	NX Unit Observation	An observation was detected in an NX Unit.	<ul style="list-style-type: none"> <li>An observation level error occurred in a Unit where an error was detected.</li> </ul>				○		page 13-49
350E0000 hex	NX Bus Cycle Delay Detected	Exceeding the NX bus cycle was detected.	<ul style="list-style-type: none"> <li>The NX bus cycle was exceeded.</li> </ul>				○		page 13-49
80220000 hex	NX Message Communications Error	An error was detected in message communications and the message frame was discarded.	<p>For the NX bus of CPU Units</p> <ul style="list-style-type: none"> <li>The message communications load is high.</li> </ul> <p>For Communications Coupler Units</p> <ul style="list-style-type: none"> <li>The message communications load is high.</li> <li>The communications cable is disconnected or broken.</li> <li>Message communications were cutoff in communications.</li> </ul>				○		page 13-50
90400000 hex	Event Log Cleared	The event log was cleared.	<ul style="list-style-type: none"> <li>The event log was cleared by the user.</li> </ul>					○	page 13-51
90420000 hex	Restart Executed	A restart was executed.	<ul style="list-style-type: none"> <li>A restart command was received.</li> </ul>					○	page 13-51
90430000 hex	Memory All Cleared	The Unit settings were cleared.	<ul style="list-style-type: none"> <li>The Clear All Memory operation was executed.</li> </ul>					○	page 13-52
94600000 hex (Ver. 1.2 or later)	I/O Check Execution Started	I/O checking was started.	<ul style="list-style-type: none"> <li>I/O checking was started.</li> </ul>					○	page 13-52

## Error Descriptions

This section describes the information that is given for individual errors.

### ● Controller Error Descriptions

The items that are used to describe individual errors (events) are described in the following copy of an error table.

<b>Event name</b>	Gives the name of the error.			<b>Event code</b>	Gives the code of the error.	
<b>Meaning</b>	Gives a short description of the error.					
<b>Source</b>	Gives the source of the error.		<b>Source details</b>	Gives details on the source of the error.	<b>Detection timing</b>	Tells when the error is detected.
	<b>Level</b>	Tells the level of influence on control. *1	<b>Log category</b>	Tells which log the error is saved in. *2		
<b>Error attributes</b>	<b>Recovery</b>	Gives the recovery method. *3				
<b>Effects</b>	<b>User program</b>	Tells what will happen to execution of the user program. *4	<b>Operation</b>	Provides special information on the operation that results from the error.		
<b>Indicators</b>	Gives the status of the built-in EtherNet/IP port and built-in EtherCAT port indicators. Indicator status is given only for errors in the EtherCAT Master Function Module and the EtherNet/IP Function Module.					
<b>System-defined variables</b>	<b>Variable</b>	<b>Data type</b>	<b>Name</b>			
	Lists the variable names, data types, and meanings for system-defined variables that provide direct error notification, that are directly affected by the error, or that contain settings that cause the error.					
<b>Cause and correction</b>	<b>Assumed cause</b>	<b>Correction</b>	<b>Prevention</b>			
	Lists the possible causes, corrections, and preventive measures for the error.					
<b>Attached information</b>	This is the attached information that is displayed by the Support Software or an HMI. *5, *6					
<b>Precautions/Remarks</b>	Provides precautions, restrictions, and supplemental information. If the user can set the event level, the event levels that can be set, the recovery method, operational information, and other information are also provided.					

\*1. One of the following:

- Major fault: Major fault level
- Partial fault: Partial fault level
- Minor fault: Minor fault level
- Observation
- Information

\*2. One of the following:

- System: System event log
- Access: Access event log

\*3. One of the following:

- Automatic recovery: Normal status is restored automatically when the cause of the error is removed.
- Error reset: Normal status is restored when the error is reset after the cause of the error is removed.
- Cycle the power supply: Normal status is restored when the power supply to the Controller is turned OFF and then back ON after the cause of the error is removed.
- Controller reset: Normal status is restored when the Controller is reset after the cause of the error is removed.
- Depends on cause: The recovery method depends on the cause of the error.

\*4. One of the following:

- Continues: Execution of the user program will continue.

- Stops: Execution of the user program stops.
  - Starts: Execution of the user program starts.
- \*5. “System information” indicates internal system information that is used by OMRON.
- \*6. Refer to the appendices of the troubleshooting manual for the connected CPU Unit or Industrial PC for the applicable range of the HMI Troubleshooter.

## ● Error Descriptions

If a manual name is given in a description, use the appropriate manual for the connected product.

<b>Event name</b>	Bus Controller Error		<b>Event code</b>	00210000 hex		
<b>Meaning</b>	An internal bus error occurred.					
<b>Source</b>	EtherCAT Master Function Module		<b>Source details</b>	EtherCAT Coupler Unit	<b>Detection timing</b>	When power is turned ON to the EtherCAT Coupler Unit or during NX bus communications
<b>Error attributes</b>	<b>Level</b>	Minor fault	<b>Recovery</b>	Cycle the power supply to the EtherCAT Coupler Unit.	<b>Log category</b>	System
<b>Effects</b>	<b>User program</b>	Continues.	<b>Operation</b>	I/O refreshing for the NX Units in the Slave Terminal stops.		
<b>System-defined variables</b>	<b>Variable</b>	<b>Data type</b>		<b>Name</b>		
	None	---		---		
<b>Cause and correction</b>	<b>Assumed cause</b>		<b>Correction</b>		<b>Prevention</b>	
	A Unit failed or an I/O communications error occurred between the Communications Coupler Unit and the NX Unit.		Mount the NX Units and End Cover securely and secure them with End Plates. Cycle the power supply to the Communications Coupler Unit. If the error occurs again even after you make the above correction, replace the Communications Coupler Unit.		None	
<b>Attached information</b>	None					
<b>Precautions/Remarks</b>	None					

<b>Event name</b>	Non-volatile Memory Hardware Error		<b>Event code</b>	00220000 hex	
<b>Meaning</b>	An error occurred in non-volatile memory.				
<b>Source</b>	EtherCAT Master Function Module	<b>Source details</b>	EtherCAT Coupler Unit	<b>Detection timing</b>	When power is turned ON to the EtherCAT Coupler Unit or when parameters are read or written
<b>Error attributes</b>	<b>Level</b>	Minor fault	<b>Recovery</b>	Cycle the power supply to the EtherCAT Coupler Unit.	<b>Log category</b> System
<b>Effects</b>	<b>User program</b>	Continues.	<b>Operation</b>	Writing to non-volatile memory will not be possible. I/O refreshing for the NX Units in the Slave Terminal stops. Messages cannot be sent to the NX Units in the Slave Terminal.	
<b>System-defined variables</b>	<b>Variable</b>	<b>Data type</b>	<b>Name</b>		
	None	---	---		
<b>Cause and correction</b>	<b>Assumed cause</b>	<b>Correction</b>	<b>Prevention</b>		
	Non-volatile memory failure	Replace the Communications Coupler Unit.	None		
<b>Attached information</b>	None				
<b>Precautions/Remarks</b>	For an EtherCAT Coupler Unit with unit version 1.2 or later, this event is detected only <i>when the power supply to the EtherCAT Coupler Unit is turned ON.</i>				

<b>Event name</b>	ESC Error		<b>Event code</b>	05010000 hex		
<b>Meaning</b>	An error occurred in the EtherCAT slave communications controller.					
<b>Source</b>	EtherCAT Master Function Module		<b>Source details</b>	EtherCAT Coupler Unit	<b>Detection timing</b>	When establishing EtherCAT communications after power is turned ON to the EtherCAT Coupler Unit
<b>Error attributes</b>	<b>Level</b>	Minor fault	<b>Recovery</b>	Cycle the power supply to the EtherCAT Coupler Unit.	<b>Log category</b>	System
<b>Effects</b>	<b>User program</b>	Continues.	<b>Operation</b>	I/O refreshing for the NX Units in the Slave Terminal stops. Messages cannot be sent to the NX Units in the Slave Terminal.		
<b>System-defined variables</b>	<b>Variable</b>	<b>Data type</b>		<b>Name</b>		
	None	---		---		
<b>Cause and correction</b>	<b>Assumed cause</b>		<b>Correction</b>		<b>Prevention</b>	
	An error occurred in the EtherCAT slave communications controller.		Replace the EtherCAT Coupler Unit.		None	
<b>Attached information</b>	None					
<b>Precautions/Remarks</b>	None					

<b>Event name</b>	ESC Initialization Error		<b>Event code</b>	05020000 hex		
<b>Meaning</b>	Initialization of the EtherCAT slave communications controller failed.					
<b>Source</b>	EtherCAT Master Function Module	<b>Source details</b>	EtherCAT Coupler Unit	<b>Detection timing</b>	When establishing EtherCAT communications after power is turned ON to the EtherCAT Coupler Unit	
<b>Error attributes</b>	<b>Level</b>	Minor fault	<b>Recovery</b>	Cycle the power supply to the EtherCAT Coupler Unit.	<b>Log category</b>	System
<b>Effects</b>	<b>User program</b>	Continues.	<b>Operation</b>	I/O refreshing for the NX Units in the Slave Terminal stops. Messages cannot be sent to the NX Units in the Slave Terminal.		
<b>System-defined variables</b>	<b>Variable</b>	<b>Data type</b>		<b>Name</b>		
	None	---		---		
<b>Cause and correction</b>	<b>Assumed cause</b>	<b>Correction</b>		<b>Prevention</b>		
	An initialization error occurred in the EtherCAT slave communications controller.	Replace the EtherCAT Coupler Unit.		None		
<b>Attached information</b>	None					
<b>Precautions/Remarks</b>	None					

<b>Event name</b>	Slave Unit Verification Error		<b>Event code</b>	05030000 hex		
<b>Meaning</b>	An error occurred in Slave Unit verification.					
<b>Source</b>	EtherCAT Master Function Module		<b>Source details</b>	EtherCAT Coupler Unit	<b>Detection timing</b>	When establishing EtherCAT communications after power is turned ON to the EtherCAT Coupler Unit
<b>Error attributes</b>	<b>Level</b>	Minor fault	<b>Recovery</b>	Cycle the power supply to the EtherCAT Coupler Unit.	<b>Log category</b>	System
<b>Effects</b>	<b>User program</b>	Continues.	<b>Operation</b>	I/O refreshing for the NX Units in the Slave Terminal stops. Messages cannot be sent to the NX Units in the Slave Terminal.		
<b>System-defined variables</b>	<b>Variable</b>	<b>Data type</b>		<b>Name</b>		
	None	---		---		
<b>Cause and correction</b>	<b>Assumed cause</b>		<b>Correction</b>		<b>Prevention</b>	
	An error occurred in Slave Unit information.		Replace the EtherCAT Coupler Unit.		None	
<b>Attached information</b>	None					
<b>Precautions/Remarks</b>	None					

<b>Event name</b>	Non-volatile Memory Control Parameter Error		<b>Event code</b>	10420000 hex	
<b>Meaning</b>	An error occurred in the control parameters.				
<b>Source</b>	EtherCAT Master Function Module	<b>Source details</b>	EtherCAT Coupler Unit	<b>Detection timing</b>	When power is turned ON to the EtherCAT Coupler Unit or when parameters are read or written
<b>Error attributes</b>	<b>Level</b>	Minor fault	<b>Recovery</b>	Cycle the power supply to the EtherCAT Coupler Unit.	<b>Log category</b> System
<b>Effects</b>	<b>User program</b>	Continues.	<b>Operation</b>	I/O refreshing for the NX Units in the Slave Terminal stops. Messages cannot be sent to the NX Units in the Slave Terminal.	
<b>System-defined variables</b>	<b>Variable</b>	<b>Data type</b>		<b>Name</b>	
	None	---		---	
<b>Cause and correction</b>	<b>Assumed cause</b>	<b>Correction</b>		<b>Prevention</b>	
	The power supply to the Communications Coupler Unit was turned OFF or Support Software communications were disconnected while writing the Unit operation settings was in progress.	Download the Unit operation settings of the Communications Coupler Unit again.		Do not turn OFF the power supply to the Communications Coupler Unit or disconnect Support Software communications while transfer of the Unit operation settings for the Communications Coupler Unit by the Support Software or save of NX Unit parameters by a message is in progress.	
<b>Attached information</b>	None				
<b>Precautions/Remarks</b>	For an EtherCAT Coupler Unit with unit version 1.2 or later, this event is detected only <i>when the power supply to the EtherCAT Coupler Unit is turned ON.</i>				

<b>Event name</b>	Memory Corruption Detected		<b>Event code</b>	10430000 hex	
<b>Meaning</b>	Memory corruption was detected.				
<b>Source</b>	EtherCAT Master Function Module		<b>Source details</b>	EtherCAT Coupler Unit	<b>Detection timing</b> Continuously
<b>Error attributes</b>	<b>Level</b>	Minor fault	<b>Recovery</b>	Cycle the power supply to the EtherCAT Coupler Unit.	<b>Log category</b> System
<b>Effects</b>	<b>User program</b>	Continues.	<b>Operation</b>	I/O refreshing for the NX Units in the Slave Terminal stops. Messages cannot be sent to the NX Units in the Slave Terminal.	
<b>System-defined variables</b>	<b>Variable</b>		<b>Data type</b>		<b>Name</b>
	None		---		---
<b>Cause and correction</b>	<b>Assumed cause</b>		<b>Correction</b>		<b>Prevention</b>
	Memory corruption was detected.		Cycle the power supply to the Communications Coupler Unit. If this error occurs again even after you cycle the power supply, replace the Communications Coupler Unit.		None
<b>Attached information</b>	None				
<b>Precautions/Remarks</b>	None				

<b>Event name</b>	Unit Configuration Error, Too Many Units		<b>Event code</b>	24A00000 hex		
<b>Meaning</b>	The number of connected NX Units exceeds the maximum value for the Communications Coupler Unit.					
<b>Source</b>	EtherCAT Master Function Module	<b>Source details</b>	EtherCAT Coupler Unit	<b>Detection timing</b>	When power is turned ON to the EtherCAT Coupler Unit or the Slave Terminal is restarted	
<b>Error attributes</b>	<b>Level</b>	Minor fault	<b>Recovery</b>	Cycle power to the EtherCAT Coupler Unit or restart the Slave Terminal.	<b>Log category</b>	System
<b>Effects</b>	<b>User program</b>	Continues.	<b>Operation</b>	The Slave Terminal stops in Pre-Operational state. I/O refreshing for the NX Units in the Slave Terminal stops. Messages cannot be sent to the NX Units in the Slave Terminal.		
<b>System-defined variables</b>	<b>Variable</b>	<b>Data type</b>		<b>Name</b>		
	None	---		---		
<b>Cause and correction</b>	<b>Assumed cause</b>	<b>Correction</b>		<b>Prevention</b>		
	More than the maximum number of NX Units is connected to the Communications Coupler Unit.	Reduce the number of NX Units that are connected to the maximum number or fewer.		Configure the EtherCAT Slave Terminal within the maximum number of NX Units.		
<b>Attached information</b>	None					
<b>Precautions/Remarks</b>	None					

<b>Event name</b>	Unit Configuration Error, Unsupported Configuration		<b>Event code</b>	24A10000 hex	
<b>Meaning</b>	An unsupported NX Unit is mounted. Or, the total byte size of all I/O data for the connected NX Units exceeds the predetermined maximum value for the Communications Coupler Unit.				
<b>Source</b>	EtherCAT Master Function Module		<b>Source details</b>	EtherCAT Coupler Unit	<b>Detection timing</b> When power is turned ON to the EtherCAT Coupler Unit or the Slave Terminal is restarted
<b>Error attributes</b>	<b>Level</b>	Minor fault	<b>Recovery</b>	Cycle power to the EtherCAT Coupler Unit or restart the Slave Terminal.	<b>Log category</b> System
<b>Effects</b>	<b>User program</b>	Continues.	<b>Operation</b>	The Slave Terminal stops in Pre-Operational state. I/O refreshing for the NX Units in the Slave Terminal stops. Messages cannot be sent to the NX Units in the Slave Terminal.	
<b>System-defined variables</b>	<b>Variable</b>		<b>Data type</b>		<b>Name</b>
	None		---		---
<b>Cause and correction</b>	<b>Assumed cause</b>		<b>Correction</b>		<b>Prevention</b>
	An unsupported NX Unit was detected.		Remove the unsupported NX Unit or replace it with a supported NX Unit.		Connect only supported NX Units to the Communications Coupler Unit.
		The total byte size of all I/O data for the connected NX Units exceeds the predetermined maximum value for the Communications Coupler Unit.	Configure the NX Units so that the total byte size of all I/O for the connected NX Units does not exceed the predetermined maximum value for the Communications Coupler Unit.		Configure the NX Units so that the total byte size of all I/O for the connected NX Units does not exceed the predetermined maximum value for the Communications Coupler Unit.
<b>Attached information</b>	Attached information 1: Unit number of the NX Unit where the error was detected				
<b>Precautions/Remarks</b>	None				

<b>Event name</b>	Unit Configuration Information Error		<b>Event code</b>	35000000 hex	
<b>Meaning</b>	An error occurred in the Unit configuration information in the Communications Coupler Unit.				
<b>Source</b>	EtherCAT Master Function Module	<b>Source details</b>	EtherCAT Coupler Unit	<b>Detection timing</b>	When power is turned ON to the EtherCAT Coupler Unit or the Slave Terminal is restarted
<b>Error attributes</b>	<b>Level</b>	Minor fault	<b>Recovery</b>	Cycle power to the EtherCAT Coupler Unit or restart the Slave Terminal.	<b>Log category</b> System
<b>Effects</b>	<b>User program</b>	Continues.	<b>Operation</b>	The Slave Terminal stops in Pre-Operational state. I/O refreshing for the NX Units in the Slave Terminal stops. Messages cannot be sent to the NX Units in the Slave Terminal.	
<b>System-defined variables</b>	<b>Variable</b>	<b>Data type</b>		<b>Name</b>	
	None	---		---	
<b>Cause and correction</b>	<b>Assumed cause</b>	<b>Correction</b>		<b>Prevention</b>	
	The power supply to the Communications Coupler Unit was turned OFF or Support Software communications were disconnected while downloading the Unit configuration information.	Clear all memory in the Communications Coupler Unit, and then download the Unit configuration information again.		Do not turn OFF the power supply to the Communications Coupler Unit or disconnect Support Software communications while downloading the Unit configuration information.	
<b>Attached information</b>	None				
<b>Precautions/Remarks</b>	None				

<b>Event name</b>	Unit Configuration Verification Error		<b>Event code</b>	35010000 hex		
<b>Meaning</b>	There is an inconsistency between the Unit configuration information in the Communications Coupler Unit and the Units that are actually connected. Or, the Unit configuration was changed during operation while the Unit configuration information was not set in the Communications Coupler Unit.					
<b>Source</b>	EtherCAT Master Function Module		<b>Source details</b>	EtherCAT Coupler Unit	<b>Detection timing</b>	When power is turned ON to the EtherCAT Coupler Unit, when the Slave Terminal is restarted, or during NX bus communications
<b>Error attributes</b>	<b>Level</b>	Minor fault	<b>Recovery</b>	Cycle power to the EtherCAT Coupler Unit or restart the Slave Terminal.	<b>Log category</b>	System
<b>Effects</b>	<b>User program</b>	Continues.	<b>Operation</b>	<p>When Fail-soft Operation Is Set to <i>Fail-soft</i> and Fail-soft Operation Is Possible</p> <ul style="list-style-type: none"> <li>EtherCAT Coupler Unit, NX Bus I/O refreshing for the NX Units that have a verification error in the Slave Terminal stops. Messages cannot be sent to the NX Units that have a verification error in the Slave Terminal.</li> </ul> <p>When Fail-soft Operation Is Set to <i>Fail-soft</i> and Fail-soft Operation Is Not Possible The operation is the same as <i>when fail-soft operation is set to Stop</i>.</p> <p>When Fail-soft Operation Is Set to <i>Stop</i></p> <ul style="list-style-type: none"> <li>EtherCAT Coupler Unit, EtherCAT Communications A <i>Slave Application Error</i> occurs. Pre-Operational state is entered.</li> <li>EtherCAT Coupler Unit, NX Bus I/O refreshing for the NX Units in the Slave Terminal stops. Messages cannot be sent to the NX Units in the Slave Terminal.</li> </ul>		
<b>System-defined variables</b>	<b>Variable</b>		<b>Data type</b>		<b>Name</b>	
	None		---		---	
<b>Cause and correction</b>	<b>Assumed cause</b>		<b>Correction</b>		<b>Prevention</b>	

An NX Unit that is registered in the Unit configuration information is not connected.	Connect the NX Units that are registered in the Unit configuration information. Or, connect the Support Software, unregister the unconnected NX Unit from the Unit configuration information, and download the Unit configuration information to the Communications Coupler Unit.	Download the Unit configuration information that contains the actually connected configuration to the Communications Coupler Unit.
A connected NX Unit does not agree with the NX Unit that is registered in the Unit configuration information.	Connect the NX Units that are registered in the Unit configuration information. Or, connect the Support Software, change the Unit configuration information to reflect the actually connected NX Units, and download the Unit configuration information to the Communications Coupler Unit.	
An NX Unit that is not registered in the Unit configuration information is connected.	Remove the NX Unit that is not registered in the Unit configuration information. Or, connect the Support Software, add the unregistered NX Unit to the Unit configuration information, and download the Unit configuration information to the Communications Coupler Unit.	
A mounted Unit is disabled in the NX Unit Mounting Setting for the Unit configuration information.	Remove the Unit that is disabled in the NX Unit Mounting Setting for the Unit configuration information. Or, connect the Support Software, enable the disabled Unit in the NX Unit Mounting Setting, download the Unit configuration information to the Communications Coupler Unit, and mount the enabled Unit.	Remove the Unit that is disabled in the NX Unit Mounting Setting for the Unit configuration information. Or, connect the Support Software, enable the disabled Unit in the NX Unit Mounting Setting, download the Unit configuration information to the Communications Coupler Unit, and mount the enabled Unit.
An NX Unit became disconnected during operation.	Turn OFF the power supply to the Slave Terminal, mount the NX Units securely, and turn the power supply to the Slave Terminal back ON.	Do not connect or disconnect NX Units during operation.
An NX Unit was connected during operation.	Cycle the power supply to the Slave Terminal.	
The serial number of a Unit that is registered in the Unit configuration information does not agree with the serial number of the Unit that is connected. (The Serial Number Check Method is set to <i>Setting = Actual device</i> .)	Download the Unit configuration information in which the serial number of the connected Unit is set to the Communications Coupler Unit.	If the Serial Number Check Method is set to <i>Setting = Actual device</i> , read the serial numbers of the actually connected Units to the Support Software and use them.

	The version of a Unit that is registered in the Unit configuration information is newer than the version of the Unit that is connected.	Create a Unit configuration information with the version of the actually connected Unit, and download it to the Communications Coupler Unit.	Make sure that the results of the compare and merge operation for the Unit configuration of the Slave Terminal <i>do not indicate any incompatibilities</i> before you download the Unit configuration information to the Communications Coupler Unit.
	The power supply to an Additional NX Unit Power Supply Unit is not turned ON.	Turn ON the power supply to the Additional NX Unit Power Supply Units before the NX Unit wait time expires.	Increase the length of the NX Unit wait time. Turn ON the power supply to the Additional NX Unit Power Supply Unit before you turn ON the power supply to the Communications Coupler Unit.
<b>Attached information</b>	Attached information 1: Unit number of the NX Unit where the error was detected Attached Information 2: Error details  0: A connected Unit has the same model number as the Unit that is registered in the Unit configuration information, but the Unit is not compatible. 1: A Unit that is registered in the Unit configuration information is not connected. 2: A Unit that is not registered in the Unit configuration information is connected.		
<b>Precautions/Remarks</b>	None		

<b>Event name</b>	NX Unit Minor Fault		<b>Event code</b>	35020000 hex	
<b>Meaning</b>	A minor fault was detected in an NX Unit.				
<b>Source</b>	EtherCAT Master Function Module		<b>Source details</b>	NX Unit	<b>Detection timing</b> Continuously
<b>Error attributes</b>	<b>Level</b>	Minor fault	<b>Recovery</b>	Depends on the error that occurred.	<b>Log category</b> Depends on the error that occurred.
<b>Effects</b>	<b>User program</b>	Continues.	<b>Operation</b>	Depends on the error that occurred.	
<b>System-defined variables</b>	<b>Variable</b>	None	<b>Data type</b>	---	
<b>Cause and correction</b>	<b>Assumed cause</b>	A minor fault level error occurred in a Unit where an error was detected.	<b>Correction</b>	Check the cause of the minor fault in the NX Unit.	
<b>Attached information</b>	None				
<b>Precautions/Remarks</b>	For an EtherCAT Coupler Unit with unit version 1.6 or earlier, this event is recorded in the event log in the EtherCAT Coupler Unit. For an EtherCAT Coupler Unit with unit version 1.7 or later, this event is not recorded in the event log.				

<b>Event name</b>	Mailbox Setting Error		<b>Event code</b>	35040000 hex		
<b>Meaning</b>	An incorrect mailbox setting was detected for the Sync Manager. (AL-Status Code: 0016 hex)					
<b>Source</b>	EtherCAT Master Function Module	<b>Source details</b>	EtherCAT Coupler Unit	<b>Detection timing</b>	When moving from Init state to Pre-Operational state.	
<b>Error attributes</b>	<b>Level</b>	Minor fault	<b>Recovery</b>	Reset the EtherCAT master parameters.	<b>Log category</b>	System
<b>Effects</b>	<b>User program</b>	Continues.	<b>Operation</b>	The Slave Terminal stops in Init state.		
<b>System-defined variables</b>	<b>Variable</b>	<b>Data type</b>		<b>Name</b>		
	None	---		---		
<b>Cause and correction</b>	<b>Assumed cause</b>	<b>Correction</b>		<b>Prevention</b>		
	An incorrect mailbox setting was detected for the Sync Manager.	<p>When the master from another manufacturer is connected Correct the mailbox setting and then download the settings to the EtherCAT master again. If the error occurs again even after you make the above correction, replace the relevant EtherCAT Coupler Unit.</p> <p>When the NJ/NX-series CPU Unit or NY-series Industrial PC is connected Cycle the power supply to the NJ/NX-series CPU Unit or NY-series Industrial PC. Then, cycle the power supply to the EtherCAT Coupler Unit. If this error occurs again even after you make the above correction, replace the relevant CPU Unit, Industrial PC, or EtherCAT Coupler Unit.</p>		Set the communications for the Slave Terminal that are set in the EtherCAT master according to the ESI.		
<b>Attached information</b>	None					
<b>Precautions/Remarks</b>	None					

<b>Event name</b>	RxPDO Setting Error		<b>Event code</b>	35050000 hex		
<b>Meaning</b>	An error was detected in the RxPDO settings. (AL-Status Code: 001D hex)					
<b>Source</b>	EtherCAT Master Function Module		<b>Source details</b>	EtherCAT Coupler Unit	<b>Detection timing</b>	When moving from Pre-Operational state to Safe-Operational state.
<b>Error attributes</b>	<b>Level</b>	Minor fault	<b>Recovery</b>	Reset the EtherCAT master parameters.	<b>Log category</b>	System
<b>Effects</b>	<b>User program</b>	Continues.	<b>Operation</b>	The Slave Terminal stops in Pre-Operational state.		
<b>System-defined variables</b>	<b>Variable</b>		<b>Data type</b>		<b>Name</b>	
	None		---		---	
<b>Cause and correction</b>	<b>Assumed cause</b>		<b>Correction</b>		<b>Prevention</b>	
	An error was detected in the RxPDO settings.		Correct the RxPDO setting and then download the settings to the EtherCAT master again.		Set the communications for the Slave Terminal that are set in the EtherCAT master according to the ESI.	
<b>Attached information</b>	None					
<b>Precautions/Remarks</b>	None					

<b>Event name</b>	TxPDO Setting Error		<b>Event code</b>	35060000 hex		
<b>Meaning</b>	An error was detected in the TxPDO settings. (AL-Status Code: 001E hex)					
<b>Source</b>	EtherCAT Master Function Module		<b>Source details</b>	EtherCAT Coupler Unit	<b>Detection timing</b>	When moving from Pre-Operational state to Safe-Operational state.
<b>Error attributes</b>	<b>Level</b>	Minor fault	<b>Recovery</b>	Reset the EtherCAT master parameters.	<b>Log category</b>	System
<b>Effects</b>	<b>User program</b>	Continues.	<b>Operation</b>	The Slave Terminal stops in Pre-Operational state.		
<b>System-defined variables</b>	<b>Variable</b>		<b>Data type</b>		<b>Name</b>	
	None		---		---	
<b>Cause and correction</b>	<b>Assumed cause</b>		<b>Correction</b>		<b>Prevention</b>	
	An error was detected in the TxPDO settings.		Correct the TxPDO setting and then download the settings to the EtherCAT master again.		Set the communications for the Slave Terminal that are set in the EtherCAT master according to the ESI.	
<b>Attached information</b>	None					
<b>Precautions/Remarks</b>	None					

<b>Event name</b>	PDO WDT Setting Error		<b>Event code</b>	35070000 hex	
<b>Meaning</b>	An incorrect PDO WDT setting was detected. (AL-Status Code: 001F hex)				
<b>Source</b>	EtherCAT Master Function Module	<b>Source details</b>	EtherCAT Coupler Unit	<b>Detection timing</b>	When moving from Pre-Operational state to Safe-Operational state.
<b>Error attributes</b>	<b>Level</b>	Minor fault	<b>Recovery</b>	Reset the EtherCAT master parameters.	<b>Log category</b> System
<b>Effects</b>	<b>User program</b>	Continues.	<b>Operation</b>	The Slave Terminal stops in Pre-Operational state.	
<b>System-defined variables</b>	<b>Variable</b>	None	<b>Data type</b>	---	
<b>Cause and correction</b>	<b>Assumed cause</b>	<b>Correction</b>		<b>Prevention</b>	
	An incorrect PDO WDT setting was detected.	Correct the PDO WDT setting and then download the settings to the EtherCAT master again.		Set the communications for the Slave Terminal that are set in the EtherCAT master according to the ESI.	
<b>Attached information</b>	None				
<b>Precautions/Remarks</b>	None				

<b>Event name</b>	SM Event Mode Setting Error		<b>Event code</b>	35080000 hex	
<b>Meaning</b>	An SM Event Mode that is not supported was set. (AL-Status Code: 0028 hex)				
<b>Source</b>	EtherCAT Master Function Module	<b>Source details</b>	EtherCAT Coupler Unit	<b>Detection timing</b>	When moving from Pre-Operational state to Safe-Operational state.
<b>Error attributes</b>	<b>Level</b>	Minor fault	<b>Recovery</b>	Reset the EtherCAT master parameters.	<b>Log category</b> System
<b>Effects</b>	<b>User program</b>	Continues.	<b>Operation</b>	The Slave Terminal stops in Pre-Operational state.	
<b>System-defined variables</b>	<b>Variable</b>	None	<b>Data type</b>	---	
<b>Cause and correction</b>	<b>Assumed cause</b>	<b>Correction</b>		<b>Prevention</b>	
	An SM Event Mode that is not supported was set.	Correct the synchronization setting and then download the settings to the EtherCAT master again.		Set the communications for the Slave Terminal that are set in the EtherCAT master according to the ESI.	
<b>Attached information</b>	None				
<b>Precautions/Remarks</b>	None				

<b>Event name</b>	TxPDO Mapping Error		<b>Event code</b>	35090000 hex		
<b>Meaning</b>	An incorrect TxPDO was set. (AL-Status Code: 0024 hex)					
<b>Source</b>	EtherCAT Master Function Module		<b>Source details</b>	EtherCAT Coupler Unit	<b>Detection timing</b>	When moving from Pre-Operational state to Safe-Operational state.
<b>Error attributes</b>	<b>Level</b>	Minor fault	<b>Recovery</b>	Reset the EtherCAT master parameters.	<b>Log category</b>	System
<b>Effects</b>	<b>User program</b>	Continues.	<b>Operation</b>	The Slave Terminal stops in Pre-Operational state.		
<b>System-defined variables</b>	<b>Variable</b>		<b>Data type</b>		<b>Name</b>	
	None		---		---	
<b>Cause and correction</b>	<b>Assumed cause</b>		<b>Correction</b>		<b>Prevention</b>	
	An incorrect TxPDO was set, e.g., the index, subindex, or size was outside of the allowable range.		Correct the TxPDO setting and then download the settings to the EtherCAT master again.		Set the communications for the Slave Terminal that are set in the EtherCAT master according to the ESI.	
<b>Attached information</b>	None					
<b>Precautions/Remarks</b>	None					

<b>Event name</b>	RxPDO Mapping Error		<b>Event code</b>	350A0000 hex		
<b>Meaning</b>	An incorrect RxPDO was set. (AL-Status Code: 0025 hex)					
<b>Source</b>	EtherCAT Master Function Module		<b>Source details</b>	EtherCAT Coupler Unit	<b>Detection timing</b>	When moving from Pre-Operational state to Safe-Operational state.
<b>Error attributes</b>	<b>Level</b>	Minor fault	<b>Recovery</b>	Reset the EtherCAT master parameters.	<b>Log category</b>	System
<b>Effects</b>	<b>User program</b>	Continues.	<b>Operation</b>	The Slave Terminal stops in Pre-Operational state.		
<b>System-defined variables</b>	<b>Variable</b>		<b>Data type</b>		<b>Name</b>	
	None		---		---	
<b>Cause and correction</b>	<b>Assumed cause</b>		<b>Correction</b>		<b>Prevention</b>	
	An incorrect RxPDO was set, e.g., the index, subindex, or size was outside of the allowable range.		Correct the RxPDO setting and then download the settings to the EtherCAT master again.		Set the communications for the Slave Terminal that are set in the EtherCAT master according to the ESI.	
<b>Attached information</b>	None					
<b>Precautions/Remarks</b>	None					

<b>Event name</b>	Illegal State Transition Request Received		<b>Event code</b>	350B0000 hex	
<b>Meaning</b>	An incorrect state transition request was received. (AL-Status Code: 0011 hex)				
<b>Source</b>	EtherCAT Master Function Module	<b>Source details</b>	EtherCAT Coupler Unit	<b>Detection timing</b>	At EtherCAT communications state transition
<b>Error attributes</b>	<b>Level</b>	Minor fault	<b>Recovery</b>	Reset the EtherCAT master parameters.	<b>Log category</b> System
<b>Effects</b>	<b>User program</b>	Continues.	<b>Operation</b>	Depends on the state when the state transition request was received.	
<b>System-defined variables</b>	<b>Variable</b>	<b>Data type</b>		<b>Name</b>	
	None	---		---	
<b>Cause and correction</b>	<b>Assumed cause</b>	<b>Correction</b>		<b>Prevention</b>	
	An incorrect state transition request was received.	Change states correctly according to EtherCAT specifications.		Change the communications state as following for the Slave Terminal: Between Init state and Pre-Operational state, between Pre-Operational state and Safe-Operational state, or between Safe-Operational state and Operational state.	
<b>Attached information</b>	None				
<b>Precautions/Remarks</b>	None				

<b>Event name</b>	Error State Transition Received		<b>Event code</b>	350C0000 hex		
<b>Meaning</b>	An unclear state transition request was received. (AL-Status Code: 0012 hex)					
<b>Source</b>	EtherCAT Master Function Module		<b>Source details</b>	EtherCAT Coupler Unit	<b>Detection timing</b>	At EtherCAT communications state transition
<b>Error attributes</b>	<b>Level</b>	Minor fault	<b>Recovery</b>	Reset the EtherCAT master parameters.	<b>Log category</b>	System
<b>Effects</b>	<b>User program</b>	Continues.	<b>Operation</b>	Depends on the state when the state transition request was received.		
<b>System-defined variables</b>	<b>Variable</b>		<b>Data type</b>		<b>Name</b>	
	None		---		---	
<b>Cause and correction</b>	<b>Assumed cause</b>		<b>Correction</b>		<b>Prevention</b>	
	An unclear state transition request was received.		Change states correctly according to EtherCAT specifications.		Change the communications state as following for the Slave Terminal: Between Init state and Pre-Operational state, between Pre-Operational state and Safe-Operational state, or between Safe-Operational state and Operational state.	
<b>Attached information</b>	None					
<b>Precautions/Remarks</b>	None					

<b>Event name</b>	Synchronization Cycle Setting Error		<b>Event code</b>	350D0000 hex		
<b>Meaning</b>	When DC Mode was confirmed, the cycle time was set to a value that made operation impossible. (AL-Status Code: 0035 hex)					
<b>Source</b>	EtherCAT Master Function Module		<b>Source details</b>	EtherCAT Coupler Unit	<b>Detection timing</b>	When moving from Pre-Operational state to Safe-Operational state.
<b>Error attributes</b>	<b>Level</b>	Minor fault	<b>Recovery</b>	Reset the EtherCAT master parameters.	<b>Log category</b>	System
<b>Effects</b>	<b>User program</b>	Continues.	<b>Operation</b>	The Slave Terminal stops in Pre-Operational state.		
<b>System-defined variables</b>	<b>Variable</b>		<b>Data type</b>		<b>Name</b>	
	None		---		---	
<b>Cause and correction</b>	<b>Assumed cause</b>		<b>Correction</b>		<b>Prevention</b>	
	When DC Mode was confirmed, the cycle time was set to a value that made operation impossible.		Correct the synchronization setting and then download the settings to the EtherCAT master again.		Set the communications for the Slave Terminal that are set in the EtherCAT master according to the ESI.	
<b>Attached information</b>	None					
<b>Precautions/Remarks</b>	None					

<b>Event name</b>	NX Unit Processing Error		<b>Event code</b>	40200000 hex	
<b>Meaning</b>	A fatal error occurred in an NX Unit.				
<b>Source</b>	EtherCAT Master Function Module	<b>Source details</b>	EtherCAT Coupler Unit	<b>Detection timing</b>	Continuously
<b>Error attributes</b>	<b>Level</b>	Minor fault	<b>Recovery</b>	Cycle the power supply to the EtherCAT Coupler Unit.	<b>Log category</b> System
<b>Effects</b>	<b>User program</b>	Continues.	<b>Operation</b>	I/O refreshing for the NX Units in the EtherCAT Slave Terminal stops. Messages cannot be sent to the NX Units in the EtherCAT Slave Terminal.	
<b>System-defined variables</b>	<b>Variable</b>	<b>Data type</b>		<b>Name</b>	
	None	---		---	
<b>Cause and correction</b>	<b>Assumed cause</b>		<b>Correction</b>		<b>Prevention</b>
	An error occurred in the software.		Contact your OMRON representative.		None
<b>Attached information</b>	Attached information 1: System information Attached information 2: System information Attached information 3: System information Attached information 4: System information				
<b>Precautions/Remarks</b>	None				

<b>Event name</b>	NX Unit Communications Timeout		<b>Event code</b>	84C00000 hex	
<b>Meaning</b>	An error occurred in I/O data communications with the NX Units.				
<b>Source</b>	EtherCAT Master Function Module		<b>Source details</b>	EtherCAT Coupler Unit	<b>Detection timing</b> Continuously
<b>Error attributes</b>	<b>Level</b>	Minor fault	<b>Recovery</b>	Reset error in EtherCAT Coupler Unit.	<b>Log category</b> System log
<b>Effects</b>	<b>User program</b>	Continues.	<b>Operation</b>	<p>When Fail-soft Operation Is Set to <i>Fail-soft</i> Not affected.</p> <p>When Fail-soft Operation Is Set to <i>Stop</i></p> <ul style="list-style-type: none"> <li>EtherCAT Coupler Unit, EtherCAT Communications <i>A Slave Application Error</i> occurs. Pre-Operational state is entered.</li> <li>EtherCAT Coupler Unit, NX Bus I/O refreshing for the NX Units in the Slave Terminal stops.</li> </ul>	
<b>System-defined variables</b>	<b>Variable</b>	<b>Data type</b>		<b>Name</b>	
	None	---		---	
<b>Cause and correction</b>	<b>Assumed cause</b>		<b>Correction</b>		<b>Prevention</b>
	An NX Unit is not mounted properly.		Mount the NX Units and End Cover securely and secure them with End Plates.		Mount the NX Units and End Cover securely and secure them with End Plates.
	An NX Unit has failed.		If the error occurs again even after you make the above correction, replace the NX Unit.		None
<b>Attached information</b>	Attached information 1: Unit number of the NX Unit where the error was detected				
<b>Precautions/Remarks</b>	None				

<b>Event name</b>	NX Unit Initialization Error		<b>Event code</b>	84C10000 hex		
<b>Meaning</b>	Initializing an NX Unit failed.					
<b>Source</b>	EtherCAT Master Function Module	<b>Source details</b>	EtherCAT Coupler Unit	<b>Detection timing</b>	When power is turned ON to the EtherCAT Coupler Unit, the Slave Terminal is restarted, an NX Unit is restarted, or an error is reset in the EtherCAT Coupler Unit	
<b>Error attributes</b>	<b>Level</b>	Minor fault	<b>Recovery</b>	Reset error in EtherCAT Coupler Unit.	<b>Log category</b>	System
<b>Effects</b>	<b>User program</b>	Continues.	<b>Operation</b>	<p>When Fail-soft Operation Is Set to <i>Fail-soft</i></p> <ul style="list-style-type: none"> <li>EtherCAT Coupler Unit, NX Bus I/O refreshing for all of the NX Units that have an initialization error in the Slave Terminal stops.</li> </ul> <p>When Fail-soft Operation Is Set to <i>Stop</i></p> <ul style="list-style-type: none"> <li>EtherCAT Coupler Unit, EtherCAT Communications A <i>Slave Application Error</i> occurs. Pre-Operational state is entered.</li> <li>EtherCAT Coupler Unit, NX Bus I/O refreshing for the NX Units in the Slave Terminal stops.</li> </ul>		
<b>System-defined variables</b>	<b>Variable</b>	<b>Data type</b>		<b>Name</b>		
	None	---		---		
<b>Cause and correction</b>	<b>Assumed cause</b>	<b>Correction</b>		<b>Prevention</b>		
	An error occurred in processing the Communications Coupler Unit.	Set and save the Unit configuration information in the Communications Coupler Unit again. If this error occurs again, check that there are no errors in the NX Unit settings and I/O data mapping information, and correct any errors that are found.		Correctly set NX Units and I/O data mapping information, and set and save the Unit configuration information in the Communications Coupler Unit.		
	An initialization error occurred in an NX Unit.	Cycle the power supply to the relevant NX Unit. If the error occurs again, replace the NX Unit.		None		
	The Channel Enable/Disable Setting for all channels of the Analog Input Unit are set to <i>Disable</i> . The Channel Enable/Disable Setting for all channels of the Analog Output Unit are set to <i>Disable</i> .	Set the Channel Enable/Disable Setting to <i>Enable</i> for at least one channel.		Set the Channel Enable/Disable Setting to <i>Disabled</i> for only the unused channels.		
<b>Attached information</b>	Attached information 1: Unit number of the NX Unit where the error was detected					

<b>Precautions/Remarks</b>	None					
<b>Event name</b>	Process Data WDT Error		<b>Event code</b>	85000000 hex		
<b>Meaning</b>	Process data communications were stopped for more than the specified period of time.					
<b>Source</b>	EtherCAT Master Function Module		<b>Source details</b>	EtherCAT Coupler Unit	<b>Detection timing</b>	Continuously
<b>Error attributes</b>	<b>Level</b>	Minor fault	<b>Recovery</b>	Reset error in EtherCAT Coupler Unit.	<b>Log category</b>	System
<b>Effects</b>	<b>User program</b>	Continues.	<b>Operation</b>	<ul style="list-style-type: none"> <li>EtherCAT Coupler Unit, EtherCAT Communications A <i>Slave Application Error</i> occurs. Safe-Operational state is entered.</li> <li>EtherCAT Coupler Unit, NX Bus Output refreshing for the NX Units in the Slave Terminal stops.</li> </ul>		
<b>System-defined variables</b>	<b>Variable</b>	<b>Data type</b>		<b>Name</b>		
	None	---		---		
<b>Cause and correction</b>	<b>Assumed cause</b>	<b>Correction</b>		<b>Prevention</b>		
	The EtherCAT communications cable is disconnected or broken.	Connect the EtherCAT communications cable securely.		Connect the EtherCAT communications cable securely.		
	There is an error in the host controller.	Check the operation of the host controller and take appropriate measures if there is a problem.		None		
<b>Attached information</b>	None					
<b>Precautions/Remarks</b>	None					

<b>Event name</b>	Synchronization Interruption Error		<b>Event code</b>	85010000 hex	
<b>Meaning</b>	A synchronization interruption error occurred.				
<b>Source</b>	EtherCAT Master Function Module	<b>Source details</b>	EtherCAT Coupler Unit	<b>Detection timing</b>	Continuously
<b>Error attributes</b>	<b>Level</b>	Minor fault	<b>Recovery</b>	Reset error in EtherCAT Coupler Unit.	<b>Log category</b> System
<b>Effects</b>	<b>User program</b>	Continues.	<b>Operation</b>	<ul style="list-style-type: none"> <li>EtherCAT Coupler Unit, EtherCAT Communications A <i>Slave Application Error</i> occurs. Safe-Operational state is entered.</li> <li>EtherCAT Coupler Unit, NX Bus Output refreshing for the NX Units in the Slave Terminal stops.</li> </ul>	
<b>System-defined variables</b>	<b>Variable</b>	<b>Data type</b>		<b>Name</b>	
	None	---		---	
<b>Cause and correction</b>	<b>Assumed cause</b>	<b>Correction</b>		<b>Prevention</b>	
	The EtherCAT communications cable is disconnected or broken.	Connect the EtherCAT communications cable securely.		Connect the EtherCAT communications cable securely.	
	There is a synchronization setting error in the EtherCAT Coupler Unit.	Set the synchronization frequency to the value set in the Sync Error Monitoring Time parameter for the EtherCAT Coupler Unit or higher.		Set the synchronization frequency to the value set in the Sync Error Monitoring Time parameter for the EtherCAT Coupler Unit or higher.	
	There is a hardware error in the EtherCAT Coupler Unit.	If the error occurs again even after you make the above correction, replace the EtherCAT Coupler Unit.		None	
<b>Attached information</b>	None				
<b>Precautions/Remarks</b>	None				

<b>Event name</b>	Synchronization Error		<b>Event code</b>	85020000 hex		
<b>Meaning</b>	A synchronization error occurred.					
<b>Source</b>	EtherCAT Master Function Module		<b>Source details</b>	EtherCAT Coupler Unit	<b>Detection timing</b>	Continuously
<b>Error attributes</b>	<b>Level</b>	Minor fault	<b>Recovery</b>	Reset error in EtherCAT Coupler Unit.	<b>Log category</b>	System
<b>Effects</b>	<b>User program</b>	Continues.	<b>Operation</b>	<ul style="list-style-type: none"> <li>EtherCAT Coupler Unit, EtherCAT Communications <i>A Slave Application Error</i> occurs. Safe-Operational state is entered.</li> <li>EtherCAT Coupler Unit, NX Bus Output refreshing for the NX Units in the Slave Terminal stops.</li> </ul>		
<b>System-defined variables</b>	<b>Variable</b>	<b>Data type</b>		<b>Name</b>		
	None	---		---		
<b>Cause and correction</b>	<b>Assumed cause</b>	<b>Correction</b>		<b>Prevention</b>		
	The EtherCAT communications cable is disconnected or broken.	Connect the EtherCAT communications cable securely.		Connect the EtherCAT communications cable securely.		
	There is a synchronization setting error in the EtherCAT master or EtherCAT Coupler Unit.	Set the communications cycle of the EtherCAT master so that the Slave Terminal can operate.		Set the communications cycle of the EtherCAT master so that the Slave Terminal can operate.		
	There is a hardware error in the EtherCAT Coupler Unit.	If the error occurs again even after you make the above correction, replace the EtherCAT Coupler Unit.		None		
<b>Attached information</b>	Attached information 1: System information					
<b>Precautions/Remarks</b>	For an EtherCAT Coupler Unit with unit version 1.6 or earlier, there is no attached information for this event.					

<b>Event name</b>	Communications Synchronization Error		<b>Event code</b>	85030000 hex	
<b>Meaning</b>	The number of consecutive communications errors in receiving the synchronization data exceeded the value that is set for the Consecutive Communications Error Detection Count parameter in the Communications Error Settings.				
<b>Source</b>	EtherCAT Master Function Module	<b>Source details</b>	EtherCAT Coupler Unit	<b>Detection timing</b>	Continuously
<b>Error attributes</b>	<b>Level</b>	Minor fault	<b>Recovery</b>	Reset error in EtherCAT Coupler Unit.	<b>Log category</b> System
<b>Effects</b>	<b>User program</b>	Continues.	<b>Operation</b>	<ul style="list-style-type: none"> <li>EtherCAT Coupler Unit, EtherCAT Communications A <i>Slave Application Error</i> occurs. Safe-Operational state is entered.</li> <li>EtherCAT Coupler Unit, NX Bus Output refreshing for the NX Units in the Slave Terminal stops.</li> </ul>	
<b>System-defined variables</b>	<b>Variable</b>	<b>Data type</b>		<b>Name</b>	
	None	---		---	
<b>Cause and correction</b>	<b>Assumed cause</b>	<b>Correction</b>		<b>Prevention</b>	
	Power to the host controller was interrupted during process data communications.	Reset the error in the host controller. This event indicates that an error was detected when the power supply to the host controller was interrupted. It does not indicate a current error.		Turn OFF the power supply to the EtherCAT Coupler Unit before you turn OFF the power supply to the host controller.	
	The EtherCAT communications cable is disconnected or broken.	Connect the EtherCAT communications cable securely.		Connect the EtherCAT communications cable securely. Disconnect an EtherCAT slave from the network or disable it before you physically remove it during EtherCAT communications.	
	Noise is entering on an EtherCAT communications cable.	Implement suitable noise countermeasures for the EtherCAT communications cables.		Implement suitable noise countermeasures for the EtherCAT communications cables.	
		Increase the set values of the PDO communications timeout detection count in the EtherCAT master settings and the Consecutive Communications Error Detection Count in the Unit operation settings for the EtherCAT Coupler Unit.		---	
	If the I/O refreshing methods that operate only when the EtherCAT Slave Terminal is in DC Mode are not necessary, operate the EtherCAT Slave Terminal in Free-Run Mode.		If the I/O refreshing methods that operate only when the EtherCAT Slave Terminal is in DC Mode are not necessary, operate the EtherCAT Slave Terminal in Free-Run Mode.		
<b>Attached information</b>	None				
<b>Precautions/Remarks</b>	None				

<b>Event name</b>	NX Unit Startup Error		<b>Event code</b>	84C50000 hex	
<b>Meaning</b>	Starting an NX Unit failed.				
<b>Source</b>	EtherCAT Master Function Module		<b>Source details</b>	EtherCAT Coupler Unit	<b>Detection timing</b> When power is turned ON to the EtherCAT Coupler Unit, the Slave Terminal is restarted, or an error is reset in the EtherCAT Coupler Unit
<b>Error attributes</b>	<b>Level</b>	Minor fault	<b>Recovery</b>	Cycle the power supply to the EtherCAT Coupler Unit or restart the EtherCAT Coupler Unit.	<b>Log category</b> System
<b>Effects</b>	<b>User program</b>	Continues.	<b>Operation</b>	<p>When Fail-soft Operation Is Set to <i>Fail-soft</i></p> <ul style="list-style-type: none"> <li>EtherCAT Coupler Unit, NX Bus I/O refreshing for all of the NX Units that have a startup error in the Slave Terminal stops. Messages cannot be sent to the NX Units that have an initialization error in the Slave Terminal.</li> </ul> <p>When Fail-soft Operation Is Set to <i>Stop</i></p> <ul style="list-style-type: none"> <li>EtherCAT Coupler Unit, EtherCAT Communications A <i>Slave Application Error</i> occurs. Pre-Operational state is entered.</li> <li>EtherCAT Coupler Unit, NX Bus I/O refreshing for the NX Units in the Slave Terminal stops. Messages cannot be sent to the NX Units that have a startup error in the Slave Terminal.</li> </ul>	
<b>System-defined variables</b>	<b>Variable</b>		<b>Data type</b>	<b>Name</b>	
	None		---	---	
<b>Cause and correction</b>	<b>Assumed cause</b>		<b>Correction</b>	<b>Prevention</b>	
	A startup error occurred in an NX Unit.		Cycle the power supply to the Communications Coupler Unit. If this error occurs again even after you cycle the power supply, replace the NX Unit.	None	
<b>Attached information</b>	Attached information 1: Slot number of the NX Unit where the error occurred				
<b>Precautions/Remarks</b>	None				

<b>Event name</b>	NX Unit Observation		<b>Event code</b>	35030000 hex		
<b>Meaning</b>	An observation was detected in an NX Unit.					
<b>Source</b>	EtherCAT Master Function Module		<b>Source details</b>	NX Unit	<b>Detection timing</b>	Continuously
<b>Error attributes</b>	<b>Level</b>	Observation	<b>Recovery</b>	Depends on the error that occurred.	<b>Log category</b>	Depends on the error that occurred.
<b>Effects</b>	<b>User program</b>	Continues.	<b>Operation</b>	Depends on the error that occurred.		
<b>System-defined variables</b>	<b>Variable</b>		<b>Data type</b>		<b>Name</b>	
	None		---		---	
<b>Cause and correction</b>	<b>Assumed cause</b>		<b>Correction</b>		<b>Prevention</b>	
	An observation level error occurred in a Unit where an error was detected.		Check the cause of the observation in the NX Unit.		---	
<b>Attached information</b>	None					
<b>Precautions/Remarks</b>	For an EtherCAT Coupler Unit with unit version 1.6 or earlier, this event is recorded in the event log in the EtherCAT Coupler Unit. For an EtherCAT Coupler Unit with unit version 1.7 or later, this event is not recorded in the event log.					

<b>Event name</b>	NX Bus Cycle Delay Detected		<b>Event code</b>	350E0000 hex		
<b>Meaning</b>	Exceeding the NX bus cycle was detected.					
<b>Source</b>	EtherCAT Master Function Module		<b>Source details</b>	EtherCAT Coupler Unit	<b>Detection timing</b>	Safe-Operational or Operational state
<b>Error attributes</b>	<b>Level</b>	Observation	<b>Recovery</b>	---	<b>Log category</b>	System
<b>Effects</b>	<b>User program</b>	Continues.	<b>Operation</b>	Not affected.		
<b>System-defined variables</b>	<b>Variable</b>		<b>Data type</b>		<b>Name</b>	
	None		---		---	
<b>Cause and correction</b>	<b>Assumed cause</b>		<b>Correction</b>		<b>Prevention</b>	
	The NX bus cycle was exceeded.		Use the Support Software and download the configuration information.		None	
<b>Attached information</b>	None					
<b>Precautions/Remarks</b>	This event occurs only when the EtherCAT Coupler Unit is in Free-Run Mode.					

<b>Event name</b>	NX Message Communications Error		<b>Event code</b>	80220000 hex		
<b>Meaning</b>	An error was detected in message communications and the message frame was discarded.					
<b>Source</b>	EtherCAT Master Function Module		<b>Source details</b>	EtherCAT Coupler Unit	<b>Detection timing</b>	During message communications
<b>Error attributes</b>	<b>Level</b>	Observation	<b>Recovery</b>	---	<b>Log category</b>	System
<b>Effects</b>	<b>User program</b>	Continues.	<b>Operation</b>	Not affected.		
<b>System-defined variables</b>	<b>Variable</b>		<b>Data type</b>		<b>Name</b>	
	None		---		---	
<b>Cause and correction</b>	<b>Assumed cause</b>		<b>Correction</b>		<b>Prevention</b>	
	For the NX bus of CPU Units					
	The message communications load is high.		Reduce the number of times that instructions are used to send NX messages.		Reduce the number of times that instructions are used to send NX messages.	
	For Communications Coupler Units					
	The message communications load is high.		Reduce the number of times that instructions are used to send NX messages.		Reduce the number of times that instructions are used to send NX messages.	
	The communications cable is disconnected or broken. This cause does not apply if attached information 2 is 0 (NX bus).		Connect the communications cable securely.		Connect the communications cable securely.	
Message communications were cutoff by executing the followings in message communications.		---		---		
<ul style="list-style-type: none"> <li>• Transfer of parameters by the Support Software</li> <li>• Restoration of the backup data (if this error occurred in the EtherCAT Slave Terminal)</li> <li>• Disconnection of an EtherCAT slave (if this error occurred in the EtherCAT Slave Terminal)</li> </ul>						
<b>Attached information</b>	Attached information 1: System information Attached Information 2: Type of communications where error occurred 0: NX bus 1: EtherCAT 2: Serial communications (USB) 3: EtherNet/IP 65535: Internal Unit communications (routing)					
<b>Precautions/Remarks</b>	None					

<b>Event name</b>	Event Log Cleared		<b>Event code</b>	90400000 hex		
<b>Meaning</b>	The event log was cleared.					
<b>Source</b>	EtherCAT Master Function Module	<b>Source details</b>	EtherCAT Coupler Unit	<b>Detection timing</b>	When commanded from user	
<b>Error attributes</b>	<b>Level</b>	Information	<b>Recovery</b>	---	<b>Log category</b>	Access
<b>Effects</b>	<b>User program</b>	Continues.	<b>Operation</b>	Not affected.		
<b>System-defined variables</b>	<b>Variable</b>	<b>Data type</b>		<b>Name</b>		
	None	---		---		
<b>Cause and correction</b>	<b>Assumed cause</b>		<b>Correction</b>		<b>Prevention</b>	
	The event log was cleared by the user.		---		---	
<b>Attached information</b>	Attached information 1: Events that were cleared 1: The system event log was cleared. 2: The access event log was cleared.					
<b>Precautions/Remarks</b>	None					

<b>Event name</b>	Restart Executed		<b>Event code</b>	90420000 hex		
<b>Meaning</b>	A restart was executed.					
<b>Source</b>	EtherCAT Master Function Module	<b>Source details</b>	EtherCAT Coupler Unit	<b>Detection timing</b>	When the Slave Terminal or an NX Unit is restarted	
<b>Error attributes</b>	<b>Level</b>	Information	<b>Recovery</b>	---	<b>Log category</b>	Access
<b>Effects</b>	<b>User program</b>	Continues.	<b>Operation</b>	Operation starts after the restart is executed.		
<b>System-defined variables</b>	<b>Variable</b>	<b>Data type</b>		<b>Name</b>		
	None	---		---		
<b>Cause and correction</b>	<b>Assumed cause</b>		<b>Correction</b>		<b>Prevention</b>	
	A restart command was received.		---		---	
<b>Attached information</b>	Attached information 1: Type of restart 0: The Slave Terminal was restarted. 1: An NX Unit was restarted. Attached information 2: Unit number of the NX Unit where the restart was executed					
<b>Precautions/Remarks</b>	None					

<b>Event name</b>	Memory All Cleared		<b>Event code</b>	90430000 hex		
<b>Meaning</b>	The Unit settings were cleared.					
<b>Source</b>	EtherCAT Master Function Module		<b>Source details</b>	EtherCAT Coupler Unit	<b>Detection timing</b>	When commanded from user
<b>Error attributes</b>	<b>Level</b>	Information	<b>Recovery</b>	---	<b>Log category</b>	Access
<b>Effects</b>	<b>User program</b>	Continues.	<b>Operation</b>	The Unit settings were cleared.		
<b>System-defined variables</b>	<b>Variable</b>		<b>Data type</b>		<b>Name</b>	
	None		---		---	
<b>Cause and correction</b>	<b>Assumed cause</b>		<b>Correction</b>		<b>Prevention</b>	
	The Clear All Memory operation was executed.		---		---	
<b>Attached information</b>	<p>Attached information 1 and 3: Unit number of the NX Unit where the Clear All Memory operation was performed. If the Clear All Memory operation was performed for the entire Slave Terminal, the information given will be 255.</p> <p>Attached information 2 and 4: Execution results</p> <ul style="list-style-type: none"> <li>0: Successful</li> <li>1: Hardware error</li> <li>2: Initialization failed</li> <li>3: Initialization not possible</li> </ul>					
<b>Precautions/Remarks</b>	Refer to the attached information for the results of the Clear All Memory operation.					

<b>Event name</b>	I/O Check Execution Started		<b>Event code</b>	94600000 hex*1		
<b>Meaning</b>	I/O checking was started.					
<b>Source</b>	EtherCAT Master Function Module		<b>Source details</b>	EtherCAT Coupler Unit	<b>Detection timing</b>	When I/O checking starts
<b>Error attributes</b>	<b>Level</b>	Information	<b>Recovery</b>	---	<b>Log category</b>	Access
<b>Effects</b>	<b>User program</b>	Continues.	<b>Operation</b>	An I/O check is started.		
<b>System-defined variables</b>	<b>Variable</b>		<b>Data type</b>		<b>Name</b>	
	None		---		---	
<b>Cause and correction</b>	<b>Assumed cause</b>		<b>Correction</b>		<b>Prevention</b>	
	I/O checking was started.		---		---	
<b>Attached information</b>	None					
<b>Precautions/Remarks</b>	None					

\*1. This event code occurs for unit version 1.2 or later of the EtherCAT Coupler Unit.

## 13-4 Resetting Errors

Current errors in a Slave Terminal are retained, unless you reset them, until you cycle the power supply or restart the Slave Terminal.

To reset errors, you must remove the cause of the current error. If you reset an error without removing the cause, the same error will occur again.



### Precautions for Correct Use

Resetting the errors does not remove the cause of the error.  
Always remove the cause of the error, and then reset the error.

You can use the following methods to reset errors in a Slave Terminal.

Method	Operation	Scope of error reset	Description
Commands from Sysmac Studio	Resetting Controller errors* <sup>1</sup>	All errors in the Controller	Reset the Controller error from the Troubleshooting Dialog Box on the Sysmac Studio.
		All errors in the Slave Terminal	Refer to <i>11-9 Resetting Errors</i> on page 11-31 for details on resetting errors in the EtherCAT Slave Terminal.
		Errors for individually specified NX Units	
	Clearing all memory for the Slave Terminal	All errors in the Slave Terminal	If the causes for the Controller errors are removed, all Controller errors in the Slave Terminals are reset.
Restarting Slave Terminals			
Commands from the user program	Resetting Controller errors in the EtherCAT Master Function Module* <sup>1</sup>	All errors in the EtherCAT Master Function Module	Execute the Reset EtherCAT Error (ResetECError) instruction in the user program of the NJ/NX/NY-series Controller.
Cycling the Unit power supply to the Slave Terminal	---	All errors in the Slave Terminal	If the causes for the Controller errors are removed, all Controller errors in the Slave Terminals are reset.

\*1. With Safety Control Units, the above operations may not be able to reset some errors depending on the contents of the errors, and you may have to access safety programs to reset them.  
Refer to the *NX-series Safety Control Unit User's Manual (Cat. No. Z930)* for information on resetting errors for Safety Control Units.

Refer to the *Sysmac Studio Version 1 Operation Manual (Cat. No. W504)* for Sysmac Studio operating procedures.

Refer to the instructions reference manual for the connected CPU Unit or Industrial PC for information on the ResetECError (Reset EtherCAT Error) instruction.



### Additional Information

Refer to the appendices of the troubleshooting manual for the connected CPU Unit or Industrial PC for the specifications for resetting EtherCAT Slave Terminal errors on an OMRON HMI.

## 13-5 Error Notification Methods

The EtherCAT Slave Terminal uses the following methods to notify the Controller or EtherCAT master that errors have occurred.

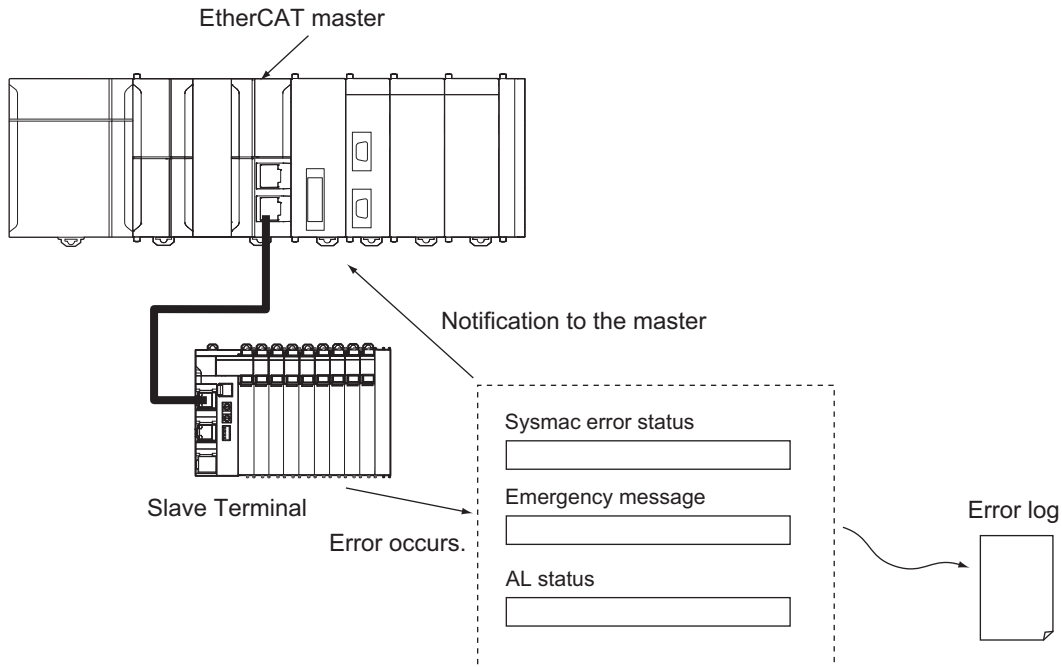

Type of error notification	Overview	Notification method
Sysmac error status	This status reports errors that are detected in the application section.	The status is assigned to the TxPDO and notified cyclically to the master.
Emergency message	The emergency message reports application level errors. The error code contains the CiA-defined error code, and an additional error code in the unique header area.	When an error occurs, the slave notifies the EtherCAT master.
AL status	This status reports errors related to EtherCAT communications. The ETG-defined method is used for the error detection and error code.	When an error occurs, the error is written to the AL status register to notify the EtherCAT master.

## 13-6 Error Notifications Based on the Sysmac Error Status

The Sysmac error status is assigned to the TxPDO to provide cyclic notifications of the level of current errors in the Slave Terminal to the EtherCAT master.

With NJ/NX/NY-series Controllers, the Sysmac error status notification allows the Controller to detect and make use of the error status in the Slave Terminal.

Detected error show in	Possible actions
System-defined variables	The error status variables can also be used to detect errors that occur in a Slave Terminal.
Controller operation	The Controller can perform operations based on the level of errors that exist in the Slave Terminal.

Refer to the troubleshooting manual for the connected CPU Unit or Industrial PC for information on the error status variables and NJ/NX/NY-series Controller operation based on the level of errors.

## 13-7 Emergency Messages

EtherCAT Slave Terminals are able to report emergency messages to the EtherCAT master by using the SDO communications if they detect errors.

### 13-7-1 Enabling/Disabling Emergency Message Notification

You can use SDO communications to specify whether notification is provided with emergency messages.

The applicable indexes are a subindex of 05 hex: (Flags) in index 10F3 hex (Diagnostic History).

The settings are as follows:

Setting value	Emergency message notification
0000 hex	No notification
0001 hex	Notification

When the Unit power supply is turned ON, the EtherCAT Slave Terminal always starts with the *No Notification* setting.

If you want to use a Slave Terminal with emergency message notification, enable it every time you turn ON the power supply.

Emergency messages cannot be sent while there is an EtherCAT communications error.

Byte	0	1	2	3	4	5	6	7
Contents	Emergency error code	Reserved.			Event codes			

Refer to *13-7-3 Emergency Error Codes* on page 13-57 for the meanings of the emergency messages.

Refer to *13-3-2 Event Codes for Errors and Troubleshooting Procedures* on page 13-14 for details on event codes.



#### Additional Information

If you use an NJ/NX-series CPU Unit or NY-series Industrial PC, you can use the setting to provide notification just by turning ON the Unit power supply. Set the *Diagnosis History/Flags* setting parameter for the EtherCAT Coupler Unit to *1 (Notification)* from the Sysmac Studio.

### 13-7-2 Error Logs

A log of the errors that were reported with emergency messages is saved in the non-volatile memory of the EtherCAT Coupler Unit. This log can save up to 128 errors. You can read the errors with SDO communications. The indexes to read are from subindexes 06 to 85 hex (Diagnosis Messages 1 to 128) in index 10F3 hex (Diagnostic History).

The error log saves errors sequentially from Diagnosis Message 1 to Diagnosis Message 128. The count returns to Diagnosis Message 1 on the 129th error. Even if an emergency message cannot be sent to the EtherCAT master, it is still saved in the error log. Errors related to the non-volatile memory are not saved in the error log.

### 13-7-3 Emergency Error Codes

The following table lists the emergency error codes that are used with EtherCAT Slave Terminals, and the meaning of each error.

Error code (hex)	Error type	Error name	Description	Error log record	Notification to EtherCAT master	Corrective action
5530	Hardware errors	Hardware Error	An error occurred in non-volatile memory.	Not saved.	Not possible.	If cycling the power supply to the EtherCAT Coupler Unit does not reset the error, replace the EtherCAT Coupler Unit.
			An error occurred in other hardware.	Saved.	Not possible.	
7040	Errors related to settings or configurations	Non-volatile Memory Control Parameter Error	An error occurred in the control parameters.	Saved.	Possible.	Write the control parameters again.
		Unit Configuration Error, Too Many Units	The number of connected NX Units exceeds the maximum value for the Communications Coupler Unit.	Saved.	Possible.	Configure the EtherCAT Slave Terminal within the maximum number of NX Units.
		Unit Configuration Error, Unsupported Configuration	The total byte size of all I/O data for the connected NX Units exceeds the predetermined maximum value for the EtherCAT Coupler Unit.	Saved.	Possible.	Configure the NX Units so that the total byte size of all I/O data for the connected NX Units does not exceed 1,024 bytes for input data or 1,024 bytes for output data.
		Unit Configuration Information Error	An error occurred in the Unit configuration information in the EtherCAT Coupler Unit.	Saved.	Possible.	Clear all memory in the EtherCAT Coupler Unit, and then download the Unit configuration information again.

Error code (hex)	Error type	Error name	Description	Error log record	Notification to EtherCAT master	Corrective action
7040	Errors related to settings or configurations	Unit Configuration Verification Error	There is an inconsistency between the Unit configuration information in the EtherCAT Coupler Unit and the Units that are actually connected.	Saved.	Possible.	<p>Cause</p> <p>An NX Unit that is registered in the Unit configuration information is not connected.</p> <p>Corrective Action</p> <p>Connect the NX Units that are registered in the Unit configuration information. Or, connect the Sysmac Studio, unregister the unconnected NX Unit from the Unit configuration information, and download the Unit configuration information to the EtherCAT Coupler Unit.</p> <hr/> <p>Cause</p> <p>A connected NX Unit does not agree with the NX Unit that is registered in the Unit configuration information.</p> <p>Corrective Action</p> <p>Connect the NX Units that are registered in the Unit configuration information. Or, connect the Sysmac Studio, change the Unit configuration information to reflect the actually connected NX Units, and download the Unit configuration information to the EtherCAT Coupler Unit.</p> <hr/> <p>Cause</p> <p>An NX Unit that is not registered in the Unit configuration information is connected.</p> <p>Corrective Action</p> <p>Remove the NX Unit that is not registered in the Unit configuration information. Or, connect the Sysmac Studio, add the NX Unit to the Unit configuration information, and download the Unit configuration information to the EtherCAT Coupler Unit.</p>
		Memory Corruption	Memory corruption was detected.	Saved.	Possible.	If the error occurs again after cycling the power supply to the EtherCAT Coupler Unit, replace the EtherCAT Coupler Unit.

Error code (hex)	Error type	Error name	Description	Error log record	Notification to EtherCAT master	Corrective action
7041	Errors related to communications with NX Units	NX Unit Communications Timeout	An error occurred in I/O data communications with the NX Units.	Saved.	Possible.	Cause The NX Unit is not mounted properly. Corrective Action Mount the NX Unit properly.
						Cause Influence from noise Corrective Action Implement noise countermeasures if there is excessive noise.
						Cause The NX Unit has failed. Corrective Action If the error occurs again even after you make the above correction, replace the NX Unit.
		NX Unit Initialization Error	Initializing an NX Unit failed.	Saved.	Possible.	Cause An error occurred in processing the EtherCAT Coupler Unit. Corrective Action Set and save the Unit configuration information in the EtherCAT Coupler Unit again. If this error occurs again, check that there are no errors in the NX Unit settings and I/O data mapping information, and correct any errors that are found.
						Cause An initialization error occurred in an NX Unit. Corrective Action Cycle the power supply to the relevant NX Unit. If the error occurs again, replace the NX Unit.
						Cause An initialization error occurred in an NX Unit. Corrective Action Cycle the power supply to the relevant NX Unit. If the error occurs again, replace the NX Unit.
NX Unit Startup Error	Starting an NX Unit failed.	Saved.	Possible.	If the error occurs again after cycling the power supply to the EtherCAT Coupler Unit, replace the NX Unit.		

## 13-8 Error Notifications Based on the AL Status

This status reports errors related to EtherCAT communications.

### 13-8-1 Procedure for Checking AL Status Codes

The AL status is reported as attached information for the *Slave Application Error* event (84280000 hex). Use the troubleshooting functions on the Sysmac Studio to check the code that is displayed for *Attached information 1* in the *Slave Application Error*. Refer to *13-8-2 AL Status Codes* on page 13-60 to troubleshoot the error identified by the AL status code.

### 13-8-2 AL Status Codes

AL status code (hex)	Status name	Contents	Error log record	Notification to Ether-CAT master	Corrective action
0001	State Transition Impossible	The number of received state transition requests exceeded the limit set by the application.	Not saved.	Possible.	An error occurred in the EtherCAT Slave Terminal. Check the event log. To check the event log of the EtherCAT slave terminal, please connect Sysmac Studio directly to the EtherCAT Coupler Unit. When this error is occurring, the CPU Unit and the EtherCAT Coupler Unit cannot communicate.
0011	Illegal State Transition Request Received	An incorrect state transition request was received.	Not saved.	Possible.	Change the status correctly.
0012	Error State Transition Received	An unclear state transition request was received.	Not saved.	Possible.	Change the status correctly.
0014	Slave Unit Verification Error	The non-volatile memory for SII backups does not match the information in the SII (VendorID, ProductCode, RevisionNo, and Serial No.).	Not saved.	Possible.	Cycle the power supply. If the error still occurs, replace the Communications Coupler Unit.

AL status code (hex)	Status name	Contents	Error log record	Notification to EtherCAT master	Corrective action
0016	Mailbox Setting Error	An incorrect mailbox setting was detected for the Sync Manager.	Not saved.	Possible.	When the master from another manufacturer is connected Correct the mailbox setting and then download the settings to the EtherCAT master again. If the error occurs again even after you make the above correction, replace the relevant EtherCAT Coupler Unit. When the NJ/NX-series CPU Unit or NY-series Industrial PC is connected Cycle the power supply to the NJ/NX-series CPU Unit or NY-series Industrial PC. Then, cycle the power supply to the EtherCAT Coupler Unit. If this error occurs again even after you make the above correction, replace the relevant CPU Unit, Industrial PC, or EtherCAT Coupler Unit.
001B	Process Data WDT Error	A timeout was detected for an I/O data send frame.	Not saved.	Possible.	Review the following items, and restart the slave based on the specifications of the connected EtherCAT master. <ul style="list-style-type: none"> <li>• Wire the EtherCAT communications cable correctly.</li> <li>• Check to see if the EtherCAT communications cable is exposed to excessive noise.</li> <li>• Set the synchronization cycle correctly.</li> </ul>
001D	RxPDO Setting Error	An error was detected in the RxPDO settings.	Not saved.	Possible.	Correct the settings, and then download the settings to the EtherCAT master again.
001E	TxPDO Setting Error	An error was detected in the TxPDO settings.	Not saved.	Possible.	Correct the settings, and then download the settings to the EtherCAT master again.
001F	PDO WDT Setting Error	An incorrect PDO WDT setting was detected.	Not saved.	Possible.	Correct the settings, and then download the settings to the EtherCAT master again.
0024	TxPDO Mapping Error	An illegal TxPDO was set.	Not saved.	Possible.	Correct the settings, and then download the settings to the EtherCAT master again.
0025	RxPDO Mapping Error	An illegal RxPDO was set.	Not saved.	Possible.	Correct the settings, and then download the settings to the EtherCAT master again.
0028	SM Event Mode Setting Error	An SM Event Mode that is not supported was set.	Not saved.	Possible.	Correct the settings, and then download the settings to the EtherCAT master again.

AL status code (hex)	Status name	Contents	Error log record	Notification to EtherCAT master	Corrective action
002C <sup>*1</sup>	Synchronization Error during Operation	Inputs of the SYNC0 interrupt signal stopped midway during operation in Safe-Operational state or Operational state.	Not saved.	Possible.	Review the following items, and restart the slave based on the specifications of the connected EtherCAT master. <ul style="list-style-type: none"> <li>• Wire the EtherCAT communications cable correctly.</li> <li>• Check to see if the EtherCAT communications cable is exposed to excessive noise.</li> <li>• Correct the synchronization cycle setting in the EtherCAT master or EtherCAT Coupler Unit.</li> </ul>
002D <sup>*2</sup>	Synchronization Error at Synchronization Start	After changing to Safe-Operational state, the first SYNC0 signal input was never detected.	Not saved.	Possible.	Review the following items, and restart the slave based on the specifications of the connected EtherCAT master. <ul style="list-style-type: none"> <li>• Wire the EtherCAT communications cable correctly.</li> <li>• Check to see if the EtherCAT communications cable is exposed to excessive noise.</li> <li>• Set the synchronization cycle correctly.</li> </ul>
0034 <sup>*3</sup>	Synchronization Error during Operation	During operation in Operational state, inputs of the SYNC0 signal continued, but refreshing of the RxPDO data failed consecutively for the specified number of times.	Not saved.	Possible.	Review the following items, and restart the slave based on the specifications of the connected EtherCAT master. <ul style="list-style-type: none"> <li>• Wire the EtherCAT communications cable correctly.</li> <li>• Check to see if the EtherCAT communications cable is exposed to excessive noise.</li> </ul>
0035	Synchronization Cycle Setting Error	When DC Mode was confirmed, the synchronization cycle was set to a value that made operation impossible.	Not saved.	Possible.	Correct the settings, and then download the settings to the EtherCAT master again.
8000	Slave Restarted	A restart was implemented with a slave restart command.	Not saved.	Possible.	---
8001	Parameter Overwrite Mode	Parameter Overwrite Mode was entered.	Not saved.	Possible.	---

AL status code (hex)	Status name	Contents	Error log record	Notification to Ether-CAT master	Corrective action
8002	Illegal Change in EtherCAT Communications Mode	An illegal change in the EtherCAT communications mode made operation impossible.	Not saved.	Possible.	Cycle the power supply to the EtherCAT Slave Terminal or restart the Slave Terminal.







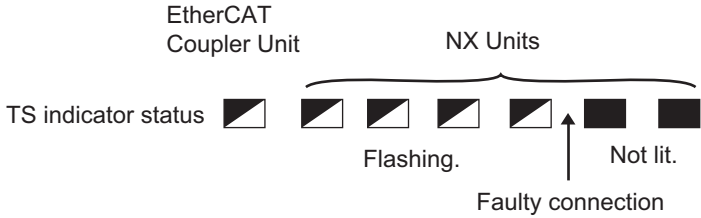

\*1. This code is reported when a *Synchronization Error* event (event code: 85020000 hex) occurs.

\*2. This code is reported when a *Synchronization Interruption Error* event (event code: 85010000 hex) occurs.

\*3. This code is reported when a *Communications Synchronization Error* event (event code: 85030000 hex) occurs.

## 13-9 Troubleshooting Other Errors

This section describes error symptoms that cannot be resolved with the methods for checking for errors and troubleshooting that were described earlier.

Status	Possible cause and correction
<p>When the Unit configuration was registered, the TS indicator on the EtherCAT Coupler Unit flashed green, and the TS indicators on the first few NX Units near the EtherCAT Coupler Unit flash green and the TS indicators on the other NX Units are not lit.</p>	<p>The NX bus connector on the left side of the Units where the TS indicators are not lit is not connected properly. Connect it properly and cycle the power supply.</p>  <p style="text-align: center;">EtherCAT Coupler Unit                      NX Units</p> <p>TS indicator status                            </p> <p style="margin-left: 150px;">Flashing.                      Not lit.</p> <p style="margin-left: 180px;">↑ Faulty connection</p>
<ul style="list-style-type: none"> <li>• All TS indicators on the EtherCAT Slave Terminal (EtherCAT Coupler Unit and NX Units) are lit green.</li> <li>• When the output of the EtherCAT Coupler is active, the OUT indicator on the Digital I/O Unit is lit yellow but the actual output is OFF.</li> <li>• A device (e.g., sensor) that is connected to the Digital I/O Unit is ON, but a signal is not input, and the IN and OUT indicators are both not lit.</li> </ul>	<ul style="list-style-type: none"> <li>• The power supply to the Additional NX Unit Power Supply Unit is not turned ON. Check the wiring and turn ON the power supply.</li> <li>• The NX bus connectors between the Units are not connected properly. Make sure that the Unit hookup guides are properly engaged.</li> <li>• The wiring for the I/O power supply is disconnected. Check the wiring.</li> </ul>

# 13-10 Troubleshooting Flow When Errors Occur

The following figure shows the standard flow for troubleshooting errors that occur when an EtherCAT Slave Terminal is used with an NJ/NX/NY-series Controller. Refer to this flow when it is difficult to isolate errors in the entire Controller.

## 13-10-1 When the Sysmac Studio Is Connected to a CPU Unit or an Industrial PC

The following flow is for troubleshooting when the Sysmac Studio is connected to an NJ/NX-series CPU Unit or an NY-series Industrial PC.

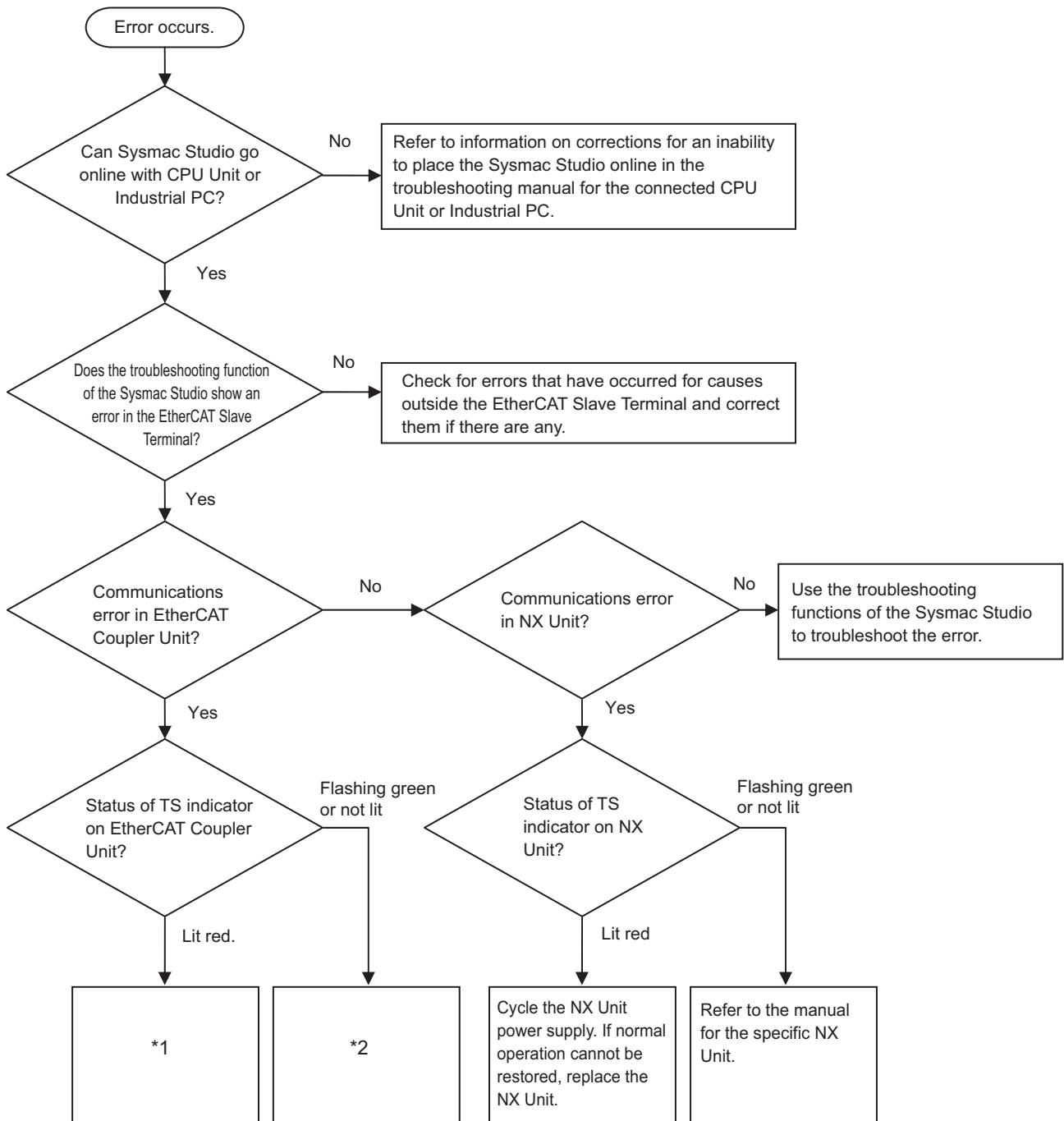

\*1. Refer to *Troubleshooting Fatal Errors in the EtherCAT Coupler Unit* on page 13-70.  
 \*2. Refer to *13-2 Checking for Errors and Troubleshooting with the Indicators* on page 13-3.

### 13-10-2 When the Sysmac Studio Is Connected to the EtherCAT Coupler Unit

The following flow is for troubleshooting when the Sysmac Studio is connected to the EtherCAT Coupler Unit.

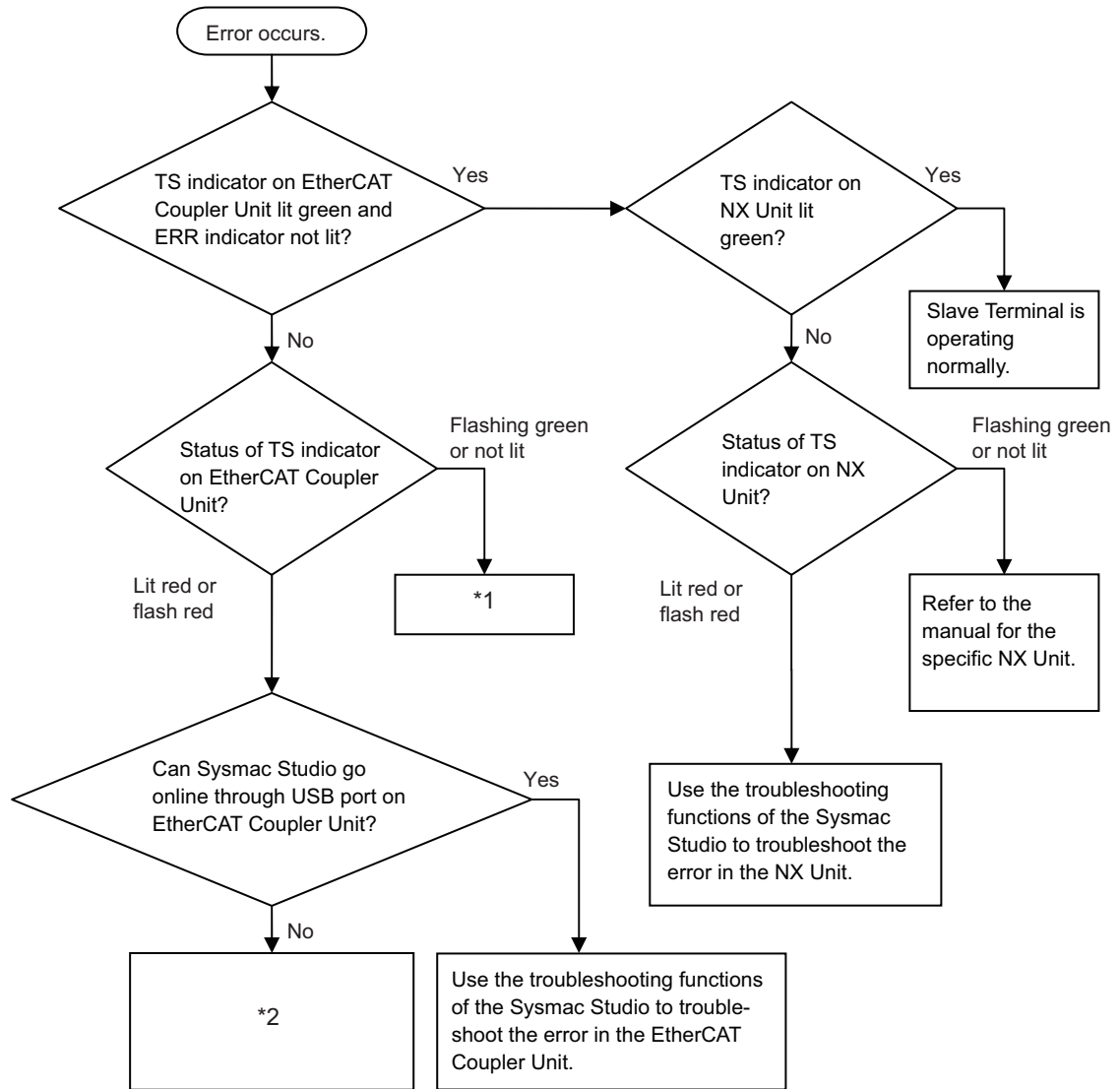

\*1. Refer to 13-2 Checking for Errors and Troubleshooting with the Indicators on page 13-3.  
 \*2. Refer to 13-11 Troubleshooting When the Sysmac Studio Cannot Go Online on page 13-68.

## 13-11 Troubleshooting When the Sysmac Studio Cannot Go Online

This section describes the troubleshooting procedures when you cannot place the Sysmac Studio online with the EtherCAT Coupler Unit.

### 13-11-1 Causes and Corrective Actions When the Sysmac Studio Cannot Go Online

The following table lists the possible causes if you cannot place the Sysmac Studio online with the EtherCAT Coupler Unit.

Cause	Description	Corrective action
Incorrect setting or faulty communications path	The settings used to place the Sysmac Studio online with the EtherCAT Coupler Unit are incorrect. Or, the communications path is faulty.	Refer to <i>Troubleshooting Incorrect Settings or a Faulty Communications Path</i> on page 13-69 under <i>13-11-2 Troubleshooting by Cause</i> on page 13-69.
Fatal error in the EtherCAT Coupler Unit	An fatal error occurred in the EtherCAT Coupler Unit.	Refer to <i>Troubleshooting Fatal Errors in the EtherCAT Coupler Unit</i> on page 13-70 under <i>13-11-2 Troubleshooting by Cause</i> on page 13-69.
Prohibiting USB connections is enabled.	A Sysmac Studio online connection through the peripheral USB port on the EtherCAT Coupler Unit is prohibited.	Set the <i>Preventing Incorrect Operation/USB Connection Prohibition Setting</i> in the Unit operation settings for the EtherCAT Coupler Unit to <i>Disable</i> . Refer to <i>Setting to Prohibit USB Connections</i> on page 11-45 for the setting procedure.

### 13-11-2 Troubleshooting by Cause

This section describes how to troubleshoot by cause.

#### Troubleshooting Incorrect Settings or a Faulty Communications Path

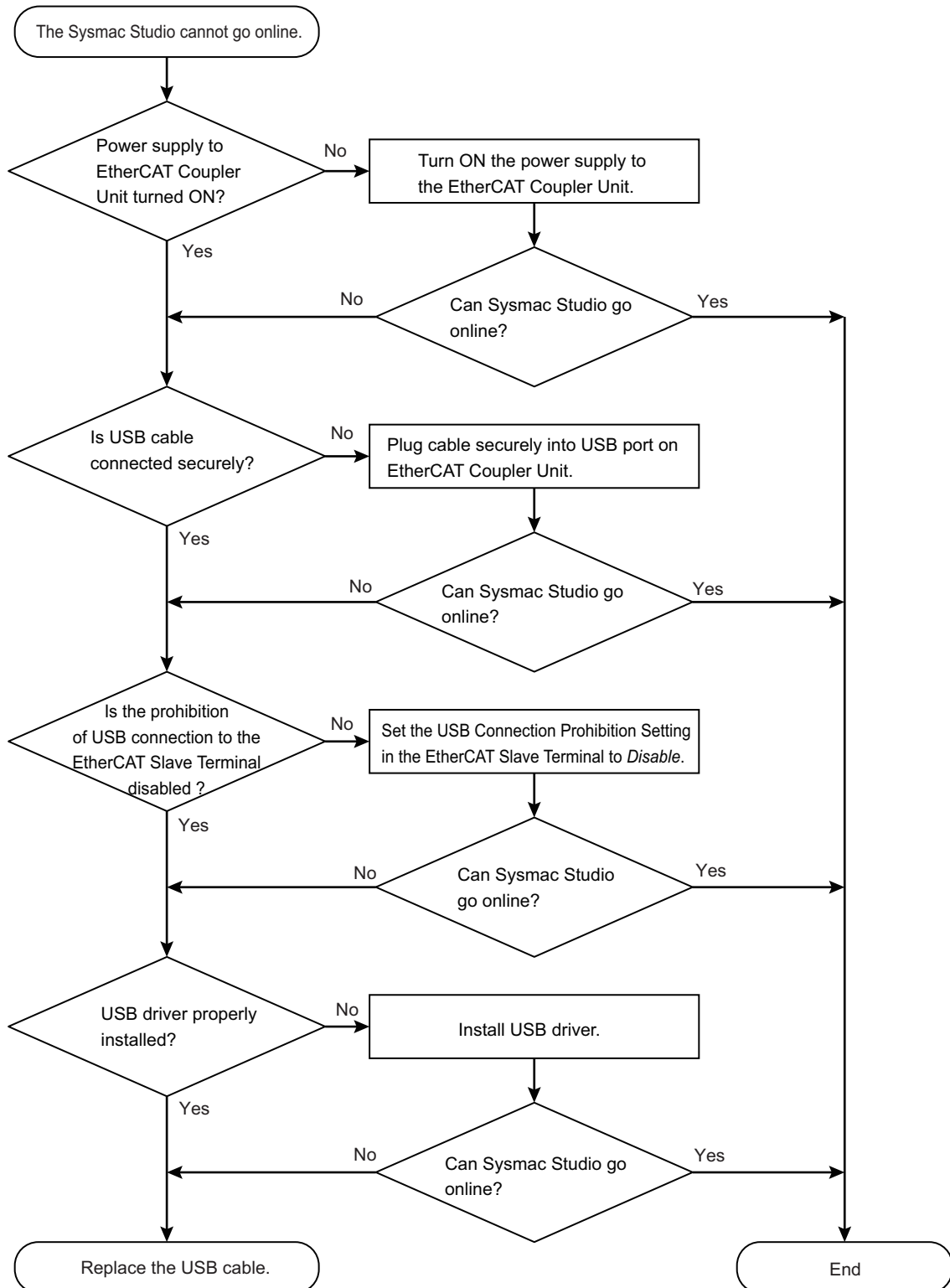

## Troubleshooting Fatal Errors in the EtherCAT Coupler Unit

This section describes the errors that cause the operation of the EtherCAT Coupler Unit to stop.

Error	Corrective action
Watchdog timer error	Cycle the power supply to the EtherCAT Coupler Unit.
EtherCAT Coupler Unit failure	If you cannot restore normal operation even after you make the above correction, replace the EtherCAT Coupler Unit.

# 14

## Maintenance and Inspection

This section describes the procedures for cleaning, inspecting, and replacing EtherCAT Coupler Units.

---

<b>14-1</b>	<b>Cleaning and Maintenance</b> .....	<b>14-2</b>
14-1-1	Cleaning .....	14-2
14-1-2	Periodic Inspections .....	14-2
<b>14-2</b>	<b>Maintenance Procedures</b> .....	<b>14-5</b>
14-2-1	Backing Up Data .....	14-5
14-2-2	Replacement Procedure for the EtherCAT Coupler Unit .....	14-5
14-2-3	Basic Replacement Procedure for NX Units .....	14-7

# 14-1 Cleaning and Maintenance

This section describes daily maintenance and the cleaning and inspection methods.

Inspect the EtherCAT Coupler Unit daily or periodically in order to keep it in optimal operating condition.

## 14-1-1 Cleaning

Clean the EtherCAT Coupler Unit regularly as described below in order to keep it in optimal operating condition.

- Wipe the network over with a soft, dry cloth when doing daily cleaning.
- If dirt remains even after wiping with a soft, dry cloth, wipe over with a cloth that has been wet with a sufficiently diluted detergent (2%) and wrung dry.
- A smudge may remain on the Unit from gum, vinyl, or tape that was left on for a long time. Remove the smudge when cleaning.



### Precautions for Correct Use

- Never use volatile solvents, such as paint thinner, benzene, or chemical wipes.
- Do not touch the NX bus connector.

## 14-1-2 Periodic Inspections

Although the major components in EtherCAT Coupler Unit have an extremely long life time, they can deteriorate under improper environmental conditions. Periodic inspections are thus required.

Inspection is recommended at least once every six months to a year, but more frequent inspections will be necessary in adverse environments.

Take immediate steps to correct the situation if any of the conditions in the following table are not met.

### Periodic Inspection Items

No.	Inspection item	Inspection details	Criteria	Correction
1	External power supply	Is the power supply voltage measured at the terminal block within standards?	Within the power supply voltage range	Use a voltage tester to check the power supply at the terminals. Take necessary steps to bring the power supply within the power supply voltage range.
2	I/O power supply	Is the power supply voltage measured at the I/O terminal block within standards?	Voltages must be within I/O specifications of each NX Unit.	Use a voltage tester to check the power voltage at the terminals. Take necessary steps to bring the I/O power supply within NX Unit standards.

No.	Inspection item	Inspection details	Criteria	Correction
3	Ambient environment	Is the ambient operating temperature within standards?	0 to 55°C	Use a thermometer to check the temperature and ensure that the ambient operating temperature remains within the allowed range of 0 to 55°C.
		Is the ambient operating humidity within standards?	Relative humidity must be 10% to 95% with no condensation.	Use a hygrometer to check the humidity and ensure that the ambient operating humidity remains between 10% and 95%. Make sure that condensation does not occur due to rapid changes in temperature.
		Is it subject to direct sunlight?	Not in direct sunlight	Protect the Controller if necessary.
		Is there an accumulation of dirt, dust, salt, metal powder, etc.?	No accumulation	Clean and protect the Controller if necessary.
		Is there water, oil, or chemical sprays hitting the Controller?	No spray	Clean and protect the Controller if necessary.
		Are there corrosive or flammable gases in the area of the Controller?	No gases	Check by smell or use a sensor.
		Is the Unit subject to shock or vibration?	Vibration resistance and shock resistance must be within specifications.	Install cushioning or other vibration and shock absorbing equipment if necessary.
		Are there noise sources near the Controller?	No significant noise sources	Either separate the Controller and noise source or protect the Controller.
4	Installation and wiring	Are the DIN Track mounting hooks for each NX Unit securely locked?	No looseness	Securely lock the DIN Track mounting hooks.
		Are the cable connectors fully inserted and locked?	No looseness	Correct any improperly installed connectors.
		Are there any loose screws on the End Plates (PFP-M)?	No looseness	Tighten loose screws with a Phillips-head screwdriver.
		Are the NX Units connected to each other along the hookup guides and until they touch the DIN track?	You must connect and fix the NX Units to the DIN track.	Connect the NX Units to each other along the hookup guides and insert them until they touch the DIN track.
		Are there any damaged external wiring cables?	No visible damage	Check visually and replace cables if necessary.

## Tools Required for Inspections

### ● Required Tools

- Phillips screwdriver
- Flat-blade screwdriver

- Voltage tester or digital voltmeter
- Industrial alcohol and pure cotton cloth

### ● **Tools Required Occasionally**

- Oscilloscope
- Thermometer and hygrometer

## 14-2 Maintenance Procedures

This section describes the procedures for backing up the data in the EtherCAT Coupler Unit, and how to replace the EtherCAT Coupler Unit.

### 14-2-1 Backing Up Data

Perform backups so that you can restore the EtherCAT Coupler Unit to its original state in the event of a failure or other problem.

The target data to back up on the EtherCAT Coupler Unit are listed below.

- Unit configuration information
- I/O allocation information
- Unit operation settings
- Hardware switch information
- Production information



#### Precautions for Correct Use

The backup data for the EtherCAT Coupler Unit includes data for NX Units that store their settings in the EtherCAT Coupler Unit. If you replace the EtherCAT Coupler Unit, you must restore the data in the EtherCAT Coupler Unit to restore the settings for these NX Units.

Refer to *9-5 Backing Up Settings* on page 9-47 for the backup methods and to the *Sysmac Studio Version 1 Operation Manual (Cat. No. W504)* for the backup procedures.

### 14-2-2 Replacement Procedure for the EtherCAT Coupler Unit

This section describes how to replace the EtherCAT Coupler Unit.

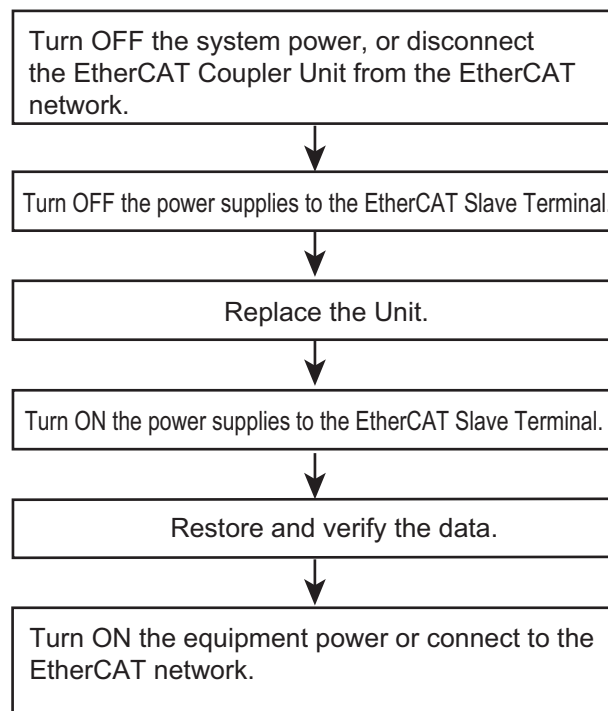

- 1** Turn OFF the power supply to all of the equipment or disconnect the EtherCAT Slave Terminal that includes the EtherCAT Coupler Unit from the EtherCAT network.
- 2** Turn OFF the Unit power supplies and I/O power supplies for the EtherCAT Slave Terminal.
- 3** Replace the EtherCAT Coupler Unit. Make sure that the hardware switches are set to the same settings as the original Unit.
- 4** Turn ON the Unit power supplies and I/O power supplies to the EtherCAT Slave Terminal.
- 5** Restore and verify data for the EtherCAT Coupler Unit.
- 6** Turn ON the power supply to all of the equipment, or connect the EtherCAT Slave Terminal to the EtherCAT network.



#### Precautions for Correct Use

---

##### Checking the Serial Number of the EtherCAT Coupler Unit

If the *Serial Number Check Method* setting on the EtherCAT master is set to *Setting = Actual device*, temporarily change this setting to *None*, and then replace the EtherCAT Coupler Unit. Get the serial number of the new EtherCAT Coupler Unit, and then set the *Serial Number Check Method* setting on the EtherCAT master to *Setting = Actual device* again.

If you replace the EtherCAT Coupler Unit with the *Serial Number Check Method* setting set to *Setting = Actual device*, a *Network Configuration Verification Error* will occur.

Refer to the user's manual for the built-in EtherCAT port on the connected CPU Unit or Industrial PC for details on the serial number check method for the EtherCAT master and details on getting the serial numbers of the EtherCAT Coupler Unit.

---



#### Additional Information

---

- Refer to *6-1 Installing Units* on page 6-2 for the procedures to mount and remove the EtherCAT Coupler Unit.
  - Refer to *Slave Replacement Methods* in the user's manual for the built-in EtherCAT port on the connected CPU Unit or Industrial PC for the procedures to disconnect and connect the EtherCAT Coupler Unit from and to the EtherCAT network.
  - Refer to the software user's manual for the connected CPU Unit or Industrial PC for the procedures for restoring and comparing data.
-

### 14-2-3 Basic Replacement Procedure for NX Units

This section describes the basic replacement procedures for the NX Units that are mounted after the EtherCAT Coupler Unit.

The procedure may differ from the one that is described below depending on the model number of the NX Unit. Refer to the manual for the specific NX Unit to replace, in addition to this manual.

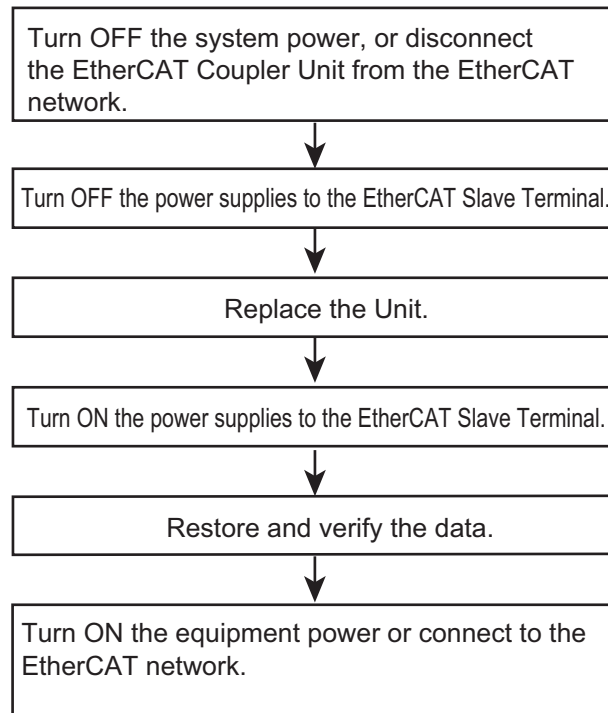

- 1** Turn OFF the power supply to all of the equipment or disconnect the EtherCAT Slave Terminal that includes the NX Unit to replace from the EtherCAT network.
- 2** Turn OFF the Unit power supplies and I/O power supplies for the EtherCAT Slave Terminal.
- 3** Replace the NX Unit. If the NX Unit has hardware switches, set the hardware switches to the same settings as on the original NX Unit.
- 4** Turn ON the Unit power supplies and I/O power supplies to the EtherCAT Slave Terminal.
- 5** Restore and verify data for the new NX Unit.
- 6** Turn ON the power supply to all of the equipment, or connect the EtherCAT Slave Terminal to the EtherCAT network.



### Precautions for Correct Use

---

#### Checking the Serial Numbers of NX Units

If the *Serial Number Check Method* setting on the EtherCAT Coupler Unit is set to *Setting = Actual device*, temporarily change this setting to *None*, and then replace the NX Unit. Get the serial number of the new NX Unit, and then set the *Serial Number Check Method* setting on the EtherCAT Coupler Unit to *Setting = Actual device* again.

If you replace the NX Unit with the *Serial Number Check Method* setting set to *Setting = Actual device*, a *Unit Configuration Verification Error* will occur.

Refer to 9-2-3 *Setting the Unit Configuration Information* on page 9-10 for details on the Serial Number Check Method setting for the EtherCAT Coupler Unit, and to 9-2-7 *Sysmac Studio Functions Used as Required* on page 9-28 for details on getting the serial numbers of NX Units.

---



### Additional Information

---

- Refer to the manual for the specific NX Unit for the procedures to mount and remove the NX Unit.
  - Refer to *Slave Replacement Methods* in the user's manual for the built-in EtherCAT port on the connected CPU Unit or Industrial PC for the procedures to disconnect and connect the EtherCAT Coupler Unit from and to the EtherCAT network.
  - Refer to the software user's manual for the connected CPU Unit or Industrial PC for the procedures for restoring and comparing data.
-



# Appendices

The appendices provide dimensions, supplemental information on the Sysmac Studio, information on special instructions, and other supplemental information.

---

<b>A-1</b>	<b>Dimensions</b> .....	<b>A-3</b>
A-1-1	EtherCAT Coupler Unit .....	A-3
A-1-2	End Cover .....	A-4
<b>A-2</b>	<b>Supplementary Information on Sysmac Studio Functions</b> .....	<b>A-5</b>
A-2-1	Functional Differences on the Sysmac Studio Based on the Connected Port .....	A-5
A-2-2	Transferring the Unit Operation Settings .....	A-6
A-2-3	Transferring Slave Terminal Setting Information through the USB Port on the EtherCAT Coupler Unit .....	A-8
<b>A-3</b>	<b>Special Instructions</b> .....	<b>A-10</b>
A-3-1	Instructions .....	A-10
A-3-2	Specifying the Targets for Instructions .....	A-11
<b>A-4</b>	<b>Connecting to Masters from Other Manufacturers</b> .....	<b>A-12</b>
A-4-1	Basic Connection Procedures .....	A-12
A-4-2	Supplementary Information for Connections with a Master from Another Manufacturer .....	A-13
<b>A-5</b>	<b>Troubleshooting with a Master from Another Manufacturer</b> .....	<b>A-18</b>
A-5-1	CoE Objects Used for Troubleshooting .....	A-18
A-5-2	Getting Information on Current Errors in EtherCAT Coupler Units and NX Units .....	A-18
A-5-3	Clearing Current Errors in EtherCAT Coupler Units and NX Units .....	A-19
A-5-4	Getting Event Logs from EtherCAT Coupler Units and NX Units .....	A-19
A-5-5	Clearing Event Logs from EtherCAT Coupler Units and NX Units .....	A-20
A-5-6	Troubleshooting Procedure .....	A-20
<b>A-6</b>	<b>Setting NX Unit Operation Settings with a Master from Another Manufacturer</b> .....	<b>A-22</b>
A-6-1	Difference between Using CoE Objects for Saving Parameters and Those for Initializing Parameters .....	A-22
A-6-2	Unit Operation Settings When Using Index 1010 Hex (Store Parameters) .....	A-23
A-6-3	Unit Operation Settings When Using Index 380F Hex (Store Parameters Command) .....	A-24
A-6-4	Unit Operation Settings When Using Index 1011 Hex (Restore Default Parameters) .....	A-26
A-6-5	Unit Operation Settings When Using Index 3810 Hex (Restore Default Parameters Command) .....	A-28

<b>A-7</b>	<b>CoE Objects</b> .....	<b>A-31</b>
A-7-1	Object Dictionary Area .....	A-31
A-7-2	Data Type .....	A-31
A-7-3	Assigning Objects .....	A-32
A-7-4	Format of Objects .....	A-34
A-7-5	Communication Objects .....	A-35
A-7-6	PDO Mapping Objects .....	A-43
A-7-7	Sync Manager Communications Objects .....	A-52
A-7-8	Manufacturer-specific Object 1 .....	A-57
A-7-9	Manufacturer-specific Object 2 .....	A-61
A-7-10	Device Profile Area .....	A-81
A-7-11	Modular Device-specific Area .....	A-86
<b>A-8</b>	<b>NX Objects</b> .....	<b>A-89</b>
A-8-1	NX Objects .....	A-89
A-8-2	Format of Object Descriptions .....	A-89
A-8-3	Unit Information Object .....	A-90
A-8-4	Objects That Accept I/O Allocations .....	A-92
A-8-5	Other Objects .....	A-95
<b>A-9</b>	<b>Terminal Block Model Numbers</b> .....	<b>A-100</b>
A-9-1	Model Number Notation .....	A-100
A-9-2	Models .....	A-100
<b>A-10</b>	<b>Functional Restrictions by Model</b> .....	<b>A-101</b>
<b>A-11</b>	<b>Version Information</b> .....	<b>A-102</b>
A-11-1	Relationship between Unit Versions .....	A-102
A-11-2	Functions That Were Added or Changed for Each Unit Version .....	A-103

# A-1 Dimensions

## A-1-1 EtherCAT Coupler Unit

### ● EtherCAT Coupler Unit Only

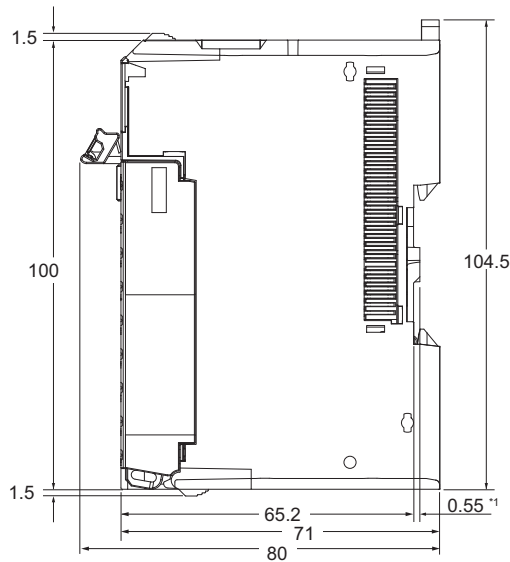
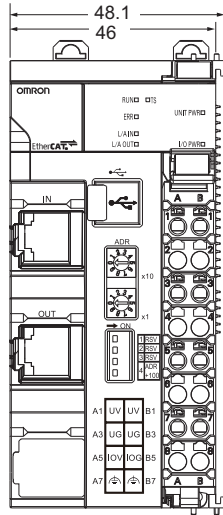

Unit: mm

\*1. The dimension is 1.35 mm for Units with lot numbers through December 2014.

### ● With Cables Connected

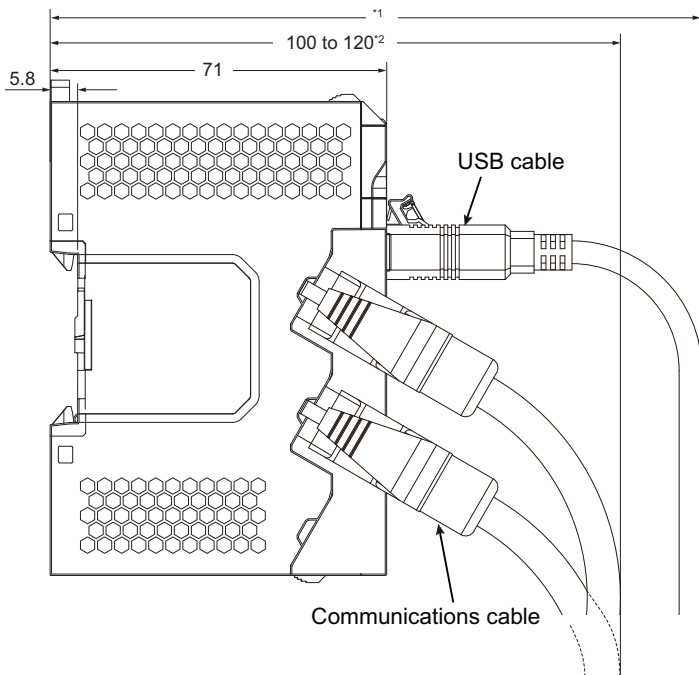

Unit: mm

\*1. This dimension depends on the specifications of the commercially available USB certified cable. Check the specifications of the USB cable that is used.

\*2. This is the dimension from the back of the Unit to the communications cables.

- 100 mm: When an MPS588-C Connector is used.
- 120 mm: When an XS6G-T421-1 Connector is used.

## A-1-2 End Cover

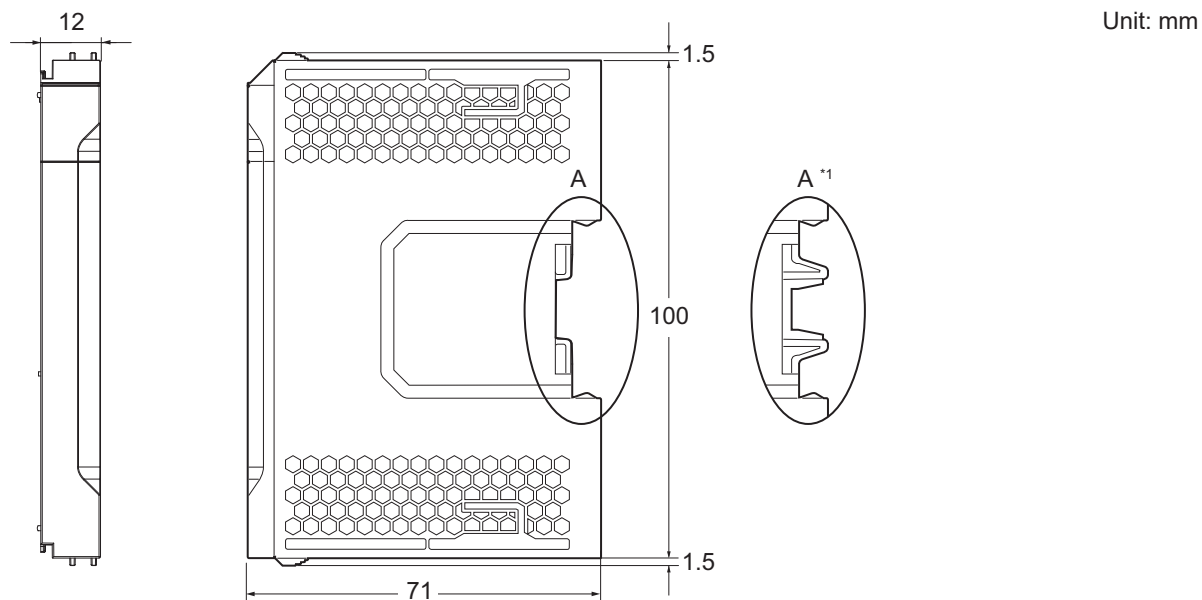

\*1. This is the shape for Units with lot numbers through December 2014.

## A-2 Supplementary Information on Sysmac Studio Functions

This section provides supplementary information on the Sysmac Studio functions that are related to the EtherCAT Slave Terminal.

### A-2-1 Functional Differences on the Sysmac Studio Based on the Connected Port

The functions that you can use on the Sysmac Studio depend on the port to which the Sysmac Studio is connected.

Yes: Supported, ---: Not supported

Functional category		Description	Sysmac Studio connection	
			CPU Unit or Industrial PC	USB port on the EtherCAT Coupler Unit
Synchronization		This function synchronizes the project data (which includes the configuration information for the EtherCAT Coupler Unit and the NX Units) between the Sysmac Studio and the Controller.	Yes	---
Backing up and restoring settings		This function saves and restores all of the settings in the EtherCAT Slave Terminal.	Yes	---
Operations for debugging	Forced refreshing	This function refreshes specific bits with forced values.	Yes	---
	Changing present values	This function is used to change the values of variables that are used in the user program and settings, and the TRUE/FALSE value of input bits and output bits.	Yes	---
	I/O Monitor	This function displays the values of the inputs and outputs.	Yes	---
Editing EtherCAT network	Comparing and merging network configurations	This function compares and matches the actual configuration with the network configuration in the project.	Yes	---
Setting node addresses		This function sets the node addresses of the EtherCAT slaves from the Sysmac Studio.	Yes	---
Operation authority verification		This function restricts write operations to the EtherCAT Coupler Unit and NX Units to users that have the proper authority.	Yes	---
Other	Verifying the EtherCAT network configuration using serial numbers	This function verifies the EtherCAT network configuration based on serial numbers.	Yes	---

Functional category	Description	Sysmac Studio connection	
		CPU Unit or Industrial PC	USB port on the EtherCAT Coupler Unit
I/O checking	This function allows you to check the wiring between NX Units and I/O devices from the Sysmac Studio connected to the peripheral USB port on the EtherCAT Coupler Unit. You can monitor inputs to NX Units and change the output values from NX Units.	---	Yes

## A-2-2 Transferring the Unit Operation Settings

### WARNING

Always confirm safety at the destination node before you transfer Unit configuration information, parameters, settings, or other data from tools such as the Sysmac Studio. The devices or machines may operate unexpectedly, regardless of the operating mode of the Controller.



The Sysmac Studio also supports the ability to transfer only the Unit operation settings for a EtherCAT Coupler Unit or NX Unit in the EtherCAT Slave Terminal. You can use this function when you need to send only Unit operation settings.

### Procedure to Transfer the Unit Operation Settings

Use the following procedures to transfer only the Unit operation settings.

- 1** Place the Sysmac Studio online with the Controller.
- 2** Click the **Edit Unit Operation Settings** Button for the Unit to which to transfer the Unit operation settings.
- 3** Click the **Transfer to Unit** Button on the Unit Operation Settings Tab Page. One of the following messages is displayed depending on whether the Unit needs to be restarted.
  - Transfer to NX Unit will be executed. Do you want to continue?*
  - Transfer to NX Unit will be executed. The Unit will be restarted after the completion because there is a change in the settings that require restarting. I/O communications with the communications master will be stopped by this operation. Are you sure you want to execute the transfer?*

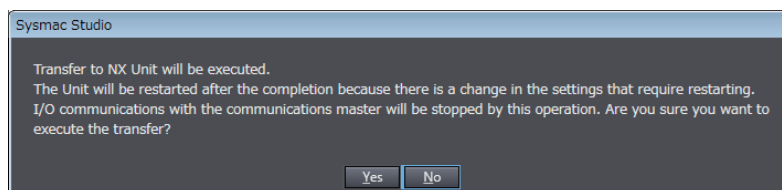

- 4 Click the **Yes** Button.  
The Unit operation settings are transferred.

## Restarting after Transferring Data

If a setting is changed that requires restarting, the Unit is restarted after the Unit operation settings are transferred.

The following table gives the types of restarts depending on the Unit to which the Unit operation settings were transferred.

Destination of Unit operation settings	Type of restart
EtherCAT Coupler Unit	Restarting the Slave Terminal
NX Unit	Restarting the Slave Terminal or the NX Unit*1

- \*1. The function to restart individual NX Units was added for a version upgrade.  
 The NX Unit is restarted if the unit versions of EtherCAT Coupler Unit and the NX Unit support restarting individual NX Units.  
 The Slave Terminal is restarted if the unit version of either the EtherCAT Coupler Unit or the NX Unit does not support restarting individual NX Units.  
 Refer to *A-11-2 Functions That Were Added or Changed for Each Unit Version* on page A-103 for the unit versions that support restarting individual NX Units.



### Precautions for Correct Use

- The EtherCAT master may detect an error when the Slave Terminal is restarted after the Unit operation settings are transferred with a direct USB connection between the Sysmac Studio and EtherCAT Coupler Unit. If an error is detected, you need to reset the error in the EtherCAT master.  
 Refer to *9-4 Transferring and Comparing Settings* on page 9-42 for a transfer method that does not produce an error on the EtherCAT master.
- When the Slave Terminal is restarted, all of the Units on the Slave Terminal perform the same operation as when the power supply is cycled. Refer to the manuals for the specific Units for the operation that is performed when the power supply is turned ON.

## A-2-3 Transferring Slave Terminal Setting Information through the USB Port on the EtherCAT Coupler Unit

### WARNING

Always confirm safety at the destination before you transfer the Unit configuration information, parameters, set values, or other data from the Sysmac Studio or other Support Software.  
 The devices or machines may operate unexpectedly, regardless of the operating mode of the Controller.



You can connect the Sysmac Studio to the USB port on the EtherCAT Coupler Unit to transfer the Slave Terminal settings information to the Slave Terminal. In this case, you cannot transfer the CPU Unit or Industrial PC user program and other data.

Use the following procedure to transfer the settings.

- 1** Connect the Sysmac Studio to the peripheral USB port on the EtherCAT Coupler Unit and place it online.
- 2** Right-click the EtherCAT Coupler Unit in the Edit Slave Terminal Configuration Tab Page, and select **Coupler Connection (USB) – Transfer to Coupler**.

The **Transfer to Coupler** Dialog Box is displayed.

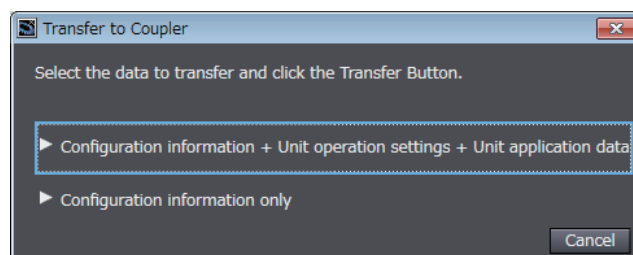

- 3** Select the data to transfer.
- To transfer the *configuration information*, *unit operation settings*, and *unit application data*, select **Configuration information + Unit operation settings + Unit application data**.
  - To transfer only the *configuration information*, select **Configuration information only**.
- An execution confirmation dialog box is displayed.

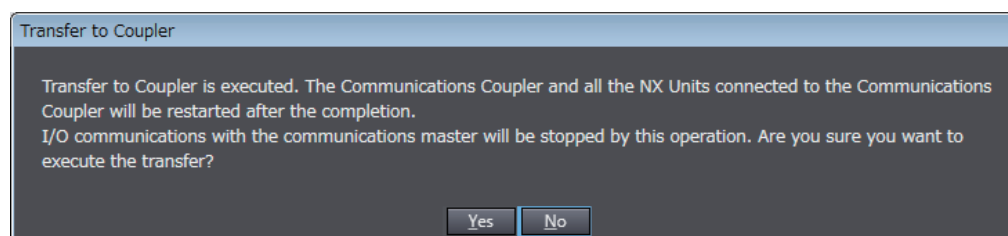

- 4** Click the **Yes** Button.
- The specified data is transferred.



#### Precautions for Correct Use

- The EtherCAT master may detect an error when the Slave Terminal is restarted after the Slave Terminal setting information is transferred with a direct USB connection between the Sysmac Studio and EtherCAT Coupler Unit. If an error is detected, you need to reset the error in the EtherCAT master.  
Refer to *9-4 Transferring and Comparing Settings* on page 9-42 for a transfer method that does not produce an error on the EtherCAT master.
- When the Slave Terminal is restarted, all of the Units on the Slave Terminal perform the same operation as when the power supply is cycled. Refer to the manuals for the specific Units for the operation that is performed when the power supply is turned ON.
- The Slave Terminal setting information must be the same between the NJ/NX-series CPU Unit or NY-series Industrial PC and the EtherCAT Slave Terminal. When you transfer the Slave Terminal setting information, always use the synchronization function from the Sysmac Studio that is connected to the CPU Unit or Industrial PC.

# A-3 Special Instructions

## A-3-1 Instructions

The following table lists the instructions that you can use in the NJ/NX-series CPU Unit or NY-series PC for the Communications Coupler Unit and the NX Units.

Type	Instruction	Name	Outline of function
System control instructions	NX_ChangeWrite Mode	Change to NX Unit Write Mode	This instruction changes the specified Communications Coupler Unit or NX Unit to the mode that allows the writing of data.*1
	NX_SaveParam	Save NX Unit Parameters	This instruction saves data that is written to the specified Communications Coupler Unit or NX Unit.*2
	RestartNXUnit	Restart NX Unit	This instruction restarts the specified Communications Coupler Unit and all NX Units that are connected to it. It can also be used to restart a specified NX Unit.*3
EtherCAT Communications Instructions	NX_ReadObj	Read NX Unit Object	This instruction reads data from the NX object for the specified Communications Coupler Unit or NX Unit.
	NX_WriteObj	Write NX Unit Object	This instruction writes data to the NX object for the specified Communications Coupler Unit or NX Unit.*2
Others	NX_ReadTotal PowerOnTime	Read NX Unit Total Power ON Time	This instruction reads the total power ON time from the specified Communications Coupler Unit or NX Unit. You can use this instruction only for an NJ-series CPU Unit with version 1.10 or later, an NX-series CPU Unit, or an NY-series Industrial PC.

\*1. You can write the parameters that are updated without restarting the Unit at any time.

\*2. Always execute the NX\_SaveParam instruction after you execute the NX\_WriteObj instruction. If you do not execute the NX\_SaveParam instruction, the object data will return to the values before the NX\_WriteObj instruction was executed when the Unit is restarted.

\*3. The function to restart a specified NX Unit was added for a version upgrade. Refer to *A-11-2 Functions That Were Added or Changed for Each Unit Version* on page A-103 for the unit versions that support this function.

**Note** You can use the NX\_ReadObj and RestartNXUnit instructions for Safety Control Units. However, you can use the RestartNXUnit instruction to restart only the Slave Terminal of the specified Communications Coupler Unit.

Refer to the instructions reference manual for the connected CPU Unit or Industrial PC for information on the instructions.

Refer to the software user's manual for the connected CPU Unit or Industrial PC for information on how to create a user program that uses these instructions.

Refer to the manual for the specific NX Unit and the instructions reference manual for the connected CPU Unit or Industrial PC for information on the instructions that you can use with NX Units.

## A-3-2 Specifying the Targets for Instructions

This section describes the methods that you use to specify the target Unit or NX objects in special instructions.

### Specifying Units

Use a variable assigned to the Unit to specify the target Unit in a special instruction. You must register the variables and assign them to the Units in advance. For details, refer to the software user's manual for the connected CPU Unit or Industrial PC.

### Specifying NX Objects

To specify an NX object in a special instruction, use the index and subindex for that NX object. Refer to *A-8 NX Objects* on page A-89 for details on indexes and subindexes of NX objects for the EtherCAT Coupler Unit, and for the meanings of those objects. Refer to the manuals for the individual NX Units for details on the NX objects for each NX Unit.

## A-4 Connecting to Masters from Other Manufacturers

This section describes the basic connection procedures and supplementary information for connecting an NX-series EtherCAT Slave Terminal to EtherCAT masters from other manufacturers.

### A-4-1 Basic Connection Procedures

Use the basic connection procedures that are described below to connect an EtherCAT Slave Terminal to a master from another manufacturer.

Refer to the manual for the master from the other manufacturer for details on that particular master.

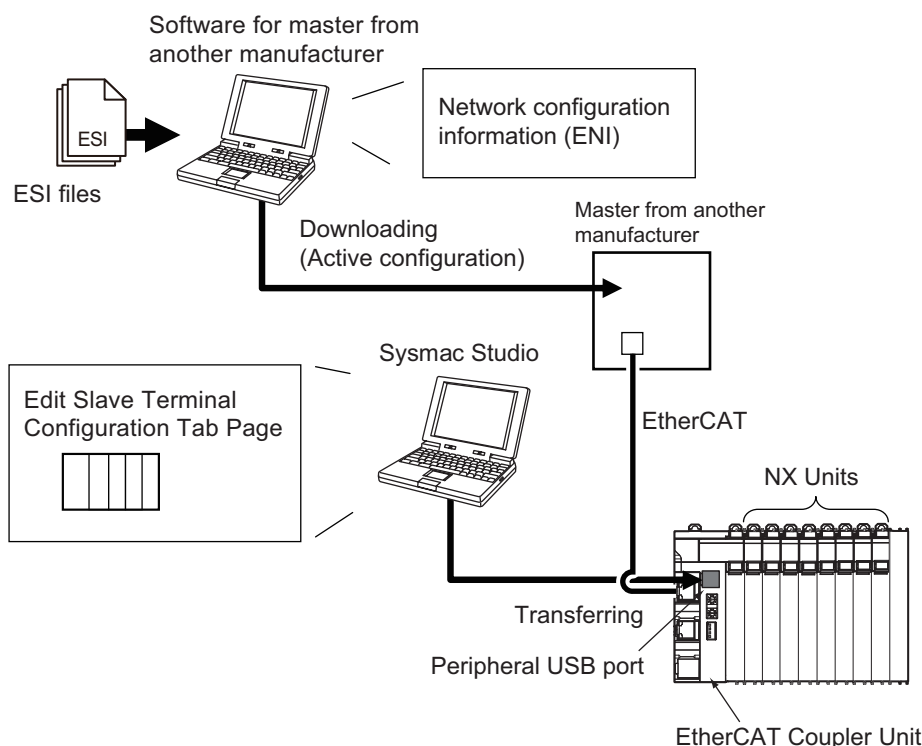

- 1 Install the Sysmac Studio and the configuration software for the master from the other manufacturer on the computer. (The *configuration software for the master from the other manufacturer* is referred to as the software for the master from the other manufacturer.)
- 2 Install the ESI files for the EtherCAT Coupler Unit and the NX Units that you will use into the software from the other manufacturer.
- 3 Perform steps 1 to 4 in 3-2 *Procedures* on page 3-7. In steps 3 and 4, use the Sysmac Studio to set up the EtherCAT Slave Terminal. In step 3 in 3-2 *Procedures* on page 3-7, the DC must be enabled for the EtherCAT slave when task period prioritized refreshing is used. When you use task period prioritized refreshing, set the Enable Distributed Clock setting to **Enabled (DC with priority in cycle time)**.

- 4** Connect the Sysmac Studio to the peripheral USB port on the EtherCAT Coupler Unit.
- 5** Turn ON the Unit power supply to the EtherCAT Slave Terminal and place the Sysmac Studio online.
- 6** Transfer the settings that you made in step 3 to the EtherCAT Slave Terminal.
- 7** Place the Sysmac Studio offline. Remove the USB cable from the EtherCAT Slave Terminal and turn ON the power to the master from the other manufacturer.
- 8** Use the software from the other manufacturer to read the I/O allocation settings (PDO Map Settings) for the EtherCAT Slave Terminal.
- 9** Use the software from the other manufacturer to create the network configuration information (ENI) based on the EtherCAT Slave Terminal information that was read in the previous step. Download the network configuration information file to the master from the other manufacturer. (This operation is called active configuration.)
- 10** Turn ON the Unit power supplies and I/O power supplies for the EtherCAT Slave Terminal, and start communications.

## A-4-2 Supplementary Information for Connections with a Master from Another Manufacturer

This section provides supplementary information that applies when you connect an EtherCAT Slave Terminal to a master from another manufacturer.

### I/O Map

This section describes the I/O map.

#### ● PDO Groups

There are four groups of PDOs. These are described in the following table.

PDO group	Description
Coupler	This PDO group is for the EtherCAT Coupler Unit.
Word	This PDO group is for NX Units that have I/O data entries in words other than Safety Control Units.
Bit	This PDO group is for NX Units that have I/O data entries in bits other than Safety Control Units. NX Units that have PDO entries (I/O entries) consisting of only BOOL data belong to this group.
Safety	This PDO group is for the Safety Control Units.

#### ● PDO Group Mapping Order

Mapping is performed in the following order of PDO groups: Coupler, Word, Bit, and then Safety. Within the PDO groups that the NX Units belong to, mapping is performed in the order of the NX Unit numbers.

- **PDO Group Boundaries**

The areas that are mapped for the PDO groups are aligned by word.

● **PDO Group Mapping Example**

An example of PDO group mapping is provided below.

Configuration Example

#0 (4 bytes) Coupler	#1 (2 bytes) Bit	#2 (2 bytes) Word	#3 (1 bit) Bit	#4 (4 bytes) Safety	#5 (2 bits) Bit	#6 (1 byte) Bit	#7 (4 bits) Bit	#8 (4 bits) Bit	#9 (2 bytes) Word	#10 (2 bytes) Safety	End Cover
----------------------------	------------------------	-------------------------	----------------------	---------------------------	-----------------------	-----------------------	-----------------------	-----------------------	-------------------------	----------------------------	--------------

Top line: NX Unit number

Middle line: Data size

Bottom line: PDO group

Mappings for Configuration Example

Offset	Bit 15	Bit 8	Bit 7	Bit 0	PDO group
+0	#0				Coupler
+1					
+2	#2				Word
+3	#9				
+4	#1				Bit
+5	#8	#7	#6	#5 #3	
+6	Reserved.			#8	
+7	#4				
+8					Safety
+9	#10				

**I/O Refreshing**

This section describes I/O refreshing.

● **I/O Refreshing with a Master from Another Manufacturer That Does Not Support DC Synchronization**

In this case, EtherCAT Slave Terminals can operate only in Free-Run Mode.

NX Units can operate in Free-Run Mode if you use Free-Run refreshing.

To operate an EtherCAT Slave Terminal in Free-Run Mode, select the following communications setting in the software from the other manufacturer so that the EtherCAT Slave Terminal operates in Free-Run Mode.

- Free-Run

With this setting, any NX Unit that has both Free-Run refreshing and another refreshing method are automatically set to use Free-Run refreshing.

● **I/O Refreshing with a Master from Another Manufacturer That Supports DC Synchronization**

In this case, EtherCAT Slave Terminals can operate only in DC Mode.

The operating specifications for the I/O refreshing methods that you can use with an NX Unit in DC Mode are given below.



I/O refreshing method for NX Units	Operation specifications
Synchronous I/O refreshing	Operation is possible. However, not all of the NX Units that use synchronous I/O refreshing in all Slave Terminals that are connected to the same EtherCAT network will read inputs and refresh outputs simultaneously.
Task period prioritized refreshing	Operation is possible.
Time stamp refreshing	Operation will not be reliable.

To operate an EtherCAT Slave Terminal in DC Mode, select one of the following communications settings in the software from the other manufacturer so that the EtherCAT Slave Terminal operates in DC Mode.

- DC for synchronization
- DC with priority in cycle time<sup>\*1</sup>

\*1. This method is supported only by the NX-ECC203.

For NX Units that have more than one I/O refreshing method, the I/O refreshing method is set automatically according to the setting. The I/O refreshing method for each setting of the NX Unit is as follows: Select the setting for the I/O refreshing method that you want to use with the NX Unit.

Communications setting	NX Units that support both Free-Run refreshing and synchronous I/O refreshing	NX Units that support Free-Run refreshing, synchronous I/O refreshing, and task period prioritized refreshing
DC for synchronization	Operates with synchronous I/O refreshing	Operates with synchronous I/O refreshing
DC with priority in cycle time		Operates with task period prioritized refreshing.

If you use task period prioritized refreshing, in addition to the communications setting in the software from the other manufacturer, you must also enable the distributed clock in the settings for the EtherCAT slave on the Sysmac Studio. For details on the setting, refer to *A-4-1 Basic Connection Procedures* on page A-12.

### ● Procedure to Change from DC Mode to Free-Run Mode

Use the following procedure to change the EtherCAT communications mode from DC Mode to Free-Run Mode.

- 1** Turn OFF the Unit power supply to the EtherCAT Slave Terminal.
- 2** Use the communications settings in the support software from the other manufacturer to change the EtherCAT communications mode to Free-Run Mode.
- 3** Turn the Unit power supply back ON.

## Referenced Objects

Objects in the EtherCAT Coupler Unit are referenced by CoE objects.

Application objects for NX Units are referenced by NX objects.

Refer to *A-7 CoE Objects* on page A-31 for details on CoE objects that are implemented by the EtherCAT Coupler Unit.

Refer to the user's manuals for NX Units for details on NX objects which serve as application objects for the NX Units.

# A-5 Troubleshooting with a Master from Another Manufacturer

You can use CoE objects to troubleshoot EtherCAT Coupler Units and NX Units even if you use a master from another manufacturer.



## Version Information

The descriptions in this section are supported for NX-ECC203 version 1.5 or later. Refer to *A-11 Version Information* on page A-102 for information on versions.

### A-5-1 CoE Objects Used for Troubleshooting

You use the following CoE objects to troubleshoot EtherCAT Coupler Units and NX Units.

Index (hex)	Object name	Reference
2002	System Error	page A-57
2100	Error History Clear	page A-59
3007	NX Unit Error Status	page A-65
3809	Coupler Unit Current Errors	page A-68
380A	Coupler Unit Event Log	page A-70
4010 + ((NX Unit No. - 01) × 20)	NX Unit Current Errors	page A-77
4011 + ((NX Unit No. - 01) × 20)	NX Unit Event Log	page A-79
4012 + ((NX Unit No. - 01) × 20)	NX Unit Event Log Clear	page A-80

### A-5-2 Getting Information on Current Errors in EtherCAT Coupler Units and NX Units

The Coupler Unit Current Errors and NX Unit Current Errors CoE objects can be read with SDO communications to detect current errors in the EtherCAT Coupler Unit and specified NX Units.

Subindex 00 hex (Number of entries) gives the number of current errors plus 1. You can determine the number of current errors by getting the number of entries.

Information on current errors is stored in the order that the errors occurred starting from subindex 02 hex (Current Error 1).

For example, if there are two current errors in the EtherCAT Coupler Unit, the object values are as given below.

Index (hex)	Subindex (hex)	Object name	Value
3809	---	Coupler Unit Current Errors	---
	00	Number of entries	02 hex
	01	Update Count	Undefined.
	02	Current Error 1	Information on the first error that occurred
	03	Current Error 2	Information on the second error that occurred
	04	Current Error 3	Undefined.
	:	:	:
	21	Current Error 32	Undefined.



**Precautions for Correct Use**

- Subindex 01 hex (Update Count) in the Coupler Unit Current Errors and NX Unit Current Errors CoE objects has no specific meaning. You can use changes in the value of subindex 01 hex (Update Count) to determine when a new error has occurred.
- If there are more than 32 current errors, the value of subindex 00 hex (Number of entries) in the Coupler Unit Current Errors and NX Unit Current Errors CoE objects will remain at 21 hex (33 decimal) and will not be updated. Therefore, use subindex 01 hex (Update Count) to determine if a new error has occurred.
- If there are less than 32 current errors, information on the current errors is stored in order starting from subindex 02 hex (Current Error 1) in the Coupler Unit Current Errors and NX Unit Current Errors CoE objects. However, when there are more than 32 current errors, the subindexes where the information on the new errors is stored is undefined. Therefore, when there are more than 32 current errors, read the values of subindex 02 hex (Current Error 1) to subindex 21 hex (Current Error 32) while monitoring the value of subindex 01 hex (Update Count). If the value of subindex 01 hex (Update Count) changes while you are reading the information on current errors, read all of the values from subindex 02 hex (Current Error 1) to 21 hex (Current Error 32).



**A-5-3 Clearing Current Errors in EtherCAT Coupler Units and NX Units**

You can write 01 hex to subindex 02 hex (Sysmac Error Status Clear) in the Sysmac Error CoE object to clear the Coupler Unit Current Errors and NX Unit Current Errors CoE objects.

Clear the Coupler Unit Current Errors and NX Unit Current Errors CoE objects only after you have removed the causes of the errors.

**A-5-4 Getting Event Logs from EtherCAT Coupler Units and NX Units**

The Coupler Unit Event Log and NX Unit Event Log CoE objects can be read with SDO communications to get the event logs from the EtherCAT Coupler Units or specified NX Units.

Subindex 00 hex (Number of entries) gives the number of events in the event log plus 1. You can determine the number of events in the event log by getting the number of entries.

The contents of the event log are stored in the order that the events occurred starting from subindex 02 hex (Event log 1).

For example, if there are two events in the event log in the EtherCAT Coupler Unit, the object values are as given below.

Index (hex)	Subindex (hex)	Object name	Value
380A	---	Coupler Unit Event Log	---
	00	Number of entries	02 hex
	01	Newest record No.	Undefined.
	02	Event log 1	Information on the first event that occurred
	03	Event log 2	Information on the second event that occurred
	04	Event log 3	Undefined.
	:	:	:
	81	Event log 128	Undefined.



### Precautions for Correct Use

- Subindex 01 hex (Newest record No.) in the Coupler Unit Event Log and NX Unit Event Log CoE objects has no specific meaning. You can use changes in the value of subindex 01 hex (Newest record No.) to determine when a new event has occurred.
- If there are more than 128 events, the value of subindex 00 hex (Number of entries) in the Coupler Unit Event Log and NX Unit Event Log CoE objects will remain at 81 hex (129 decimal) and will not be updated. Therefore, use subindex 01 hex (Newest record No.) to determine if a new event has occurred.
- If there are less than 128 events, the contents of the event log is stored in order starting from subindex 02 hex (Event log 1) in the Coupler Unit Event Log and NX Unit Event Log CoE objects. However, when there are more than 128 events in the event log, the subindexes where the information on the new events is stored is undefined. Therefore, when there are more than 128 events in the event log, read the values of subindex 02 hex (Event log 1) to subindex 81 hex (Event log 128) while monitoring the value of subindex 01 hex (Newest record No.). If the value of subindex 01 hex (Newest record No.) changes while you are reading the information on events, read all of the values from subindex 02 hex (Event log 1) to 81 hex (Event log 128).

## A-5-5 Clearing Event Logs from EtherCAT Coupler Units and NX Units

You can write 6C636C65 hex (“l” “c” “l” “e” = elcl) to the Error History Clear CoE object to clear the contents of the Coupler Unit Event Log CoE object.

You can write 6C636C65 hex (“l” “c” “l” “e” = elcl) to the NX Unit Event Log Clear CoE object to clear the contents of the NX Unit Event Log CoE object.

## A-5-6 Troubleshooting Procedure

Use the following procedure to troubleshoot EtherCAT Coupler Units and NX Units even if you use a master from another manufacturer.

- 1** Monitor the NX Unit Error Status CoE object.
- 2** If an error is detected, read the Coupler Unit Current Errors and NX Unit Current Errors CoE objects.  
If subindex 01 hex (Update Count) changes while you are reading the data, read the subindex data again from the beginning.
- 3** Use the event code and attached information stored in the obtained objects to determine the cause of the error and correction in the manual.
- 4** Clear the Coupler Unit Current Errors and NX Unit Current Errors CoE objects.

If a power interruption occurs after the error or if you need to check the frequency and types of errors that occurred in the past, check the event logs of the EtherCAT Coupler Unit and NX Unit.



### Precautions for Correct Use

---

Some NX Unit errors require special procedures to clear the errors. These errors cannot be cleared with the above method. Refer to the user's manuals of the NX Units for details on clearing errors.

---

# A-6 Setting NX Unit Operation Settings with a Master from Another Manufacturer

You can use CoE objects to set the Unit operation settings for EtherCAT Coupler Units and NX Units with a master from another manufacturer.



## Version Information

The descriptions in this section are supported for NX-ECC203 version 1.5 or later. Refer to *A-11 Version Information* on page A-102 for information on versions.

### A-6-1 Difference between Using CoE Objects for Saving Parameters and Those for Initializing Parameters

When you set the Unit operation settings for NX Units with a master from another manufacturer, a saving of parameters that are set in the NX Units is required. An initialization of parameters may also be required.

The following table provides two CoE objects each for saving the parameters and initializing the parameters. Their features are different.

Application	CoE Object	Feature
Saving parameters	Index 1010 hex (Store Parameters)	<ul style="list-style-type: none"> <li>It can be created by the user program in a relatively simple way.</li> <li>A timeout may occur.*1</li> </ul>
	Index 380F hex (Store Parameters Command)	<ul style="list-style-type: none"> <li>A timeout does not occur.*2</li> </ul>
Initializing parameters	Index 1011 hex (Restore Default Parameters)	<ul style="list-style-type: none"> <li>It can be created by the user program in a relatively simple way.</li> <li>A timeout may occur.*1</li> </ul>
	Index 3810 hex (Restore Default Parameters Command)	<ul style="list-style-type: none"> <li>A timeout does not occur.*2</li> </ul>

\*1. When you use this object, an SDO response is not returned to the EtherCAT master until the processing is completed. Therefore, a timeout may occur depending on the timeout time set in the EtherCAT master.

\*2. When you use this object, an SDO response is immediately returned to the EtherCAT master when the command is acknowledged. Therefore, a timeout does not occur. Refer to object values of the command status to confirm whether the processing is completed.

When saving the parameters, for example, consider the feature and use the CoE objects separately as follows.

- 1** Use index 1010 hex (Store Parameters) to confirm the operation.
- 2** If a timeout does not occur, use index 1010 hex (Store Parameters) for actual operation. If a timeout occurs, use index 380F hex (Store Parameters Command) for actual operation.

Similarly, when initializing the parameters, use index 1011 hex (Restore Default Parameters) if a timeout does not occur and use index 3810 hex (Restore Default Parameters Command) if a timeout occurs by confirming the operation.

## A-6-2 Unit Operation Settings When Using Index 1010 Hex (Store Parameters)

This section describes the Unit operation settings when using index 1010 hex (Store Parameters).

### CoE Objects to Use

The following CoE objects are used to set Unit operation settings in NX Units.

Index (hex)	Object name	Reference
1010	Store Parameters	page A-36
3005	NX Unit Message Enabled Status	page A-63
3006	NX Unit I/O Data Active Status	page A-64
380B	Switch Parameter Write Mode	page A-71
380E	NX Unit Restart	page A-73
5000 + ((NX Unit No. - 01) × 20)	The object name depends on the specifications of the NX Unit.	page A-80

### Unit Operation Setting Procedure

Use the following procedure to set NX Unit operation settings with a master from another manufacturer.

- 1** Use index 3005 hex (NX Unit Message Enabled Status) to confirm that message communications are enabled for the Unit for which to set the Unit operation settings.
- 2** Use index 380B hex (Switch Parameter Write Mode) to change the Unit to Parameter Write Mode.
- 3** Change the CoE object for the Unit operation settings to change in the Unit.
- 4** Use index 1010 hex (Store Parameters) to save the parameters of the Unit.
- 5** Use index 380E hex (NX Unit Restart) to restart the Unit.
- 6** Use index 3006 hex (NX Unit I/O Data Active Status) to confirm that the Unit is performing I/O data communications.

### Example for Unit Operation Settings

The following example shows setting Unit operation settings for an EtherCAT Coupler Unit and NX Unit with a master from another manufacturer.

The conditions are given in the following table.

Item	Description
Unit	NX-TS3201
Unit Number	4
Unit operation settings	The <i>Channel 1 Enable/Disable</i> object (index 5000 hex and subindex 01 hex) is set to <i>disable</i> (FALSE).

The procedure is given in the following table.

Step	Accessed CoE object			Processing
	Index (hex)	Subindex (hex)	Object name	
1	3005	---	NX Unit Message Enabled Status	Confirm that the value of bit 4 is TRUE because the unit number of the Unit is 4.
		01	NX Unit Message Enabled Status 15 <sup>*1</sup>	
2	380B	---	Switch Parameter Write Mode	Write a value of 50525752 hex. <sup>*2</sup>
		04	Switch Parameter Write Mode NX Unit 4	
3	5060 <sup>*3</sup>	---	---	Write a value of FALSE.
		01	Channel Enable/Disable <sup>*4</sup>	
4	1010	---	Store Parameters	Write a value of 73617665 hex. <sup>*5</sup>
		07	Store NX Unit 4 Parameters	
5	380E	---	NX Unit Restart	Write a value of 0000 hex.
		04	NX Unit 4 Restart	
6	3006	---	NX Unit I/O Data Active Status	Confirm that the value of bit 4 is TRUE because the unit number of the Unit is 4.
		01	NX Unit I/O Data Active Status 15 <sup>*6</sup>	

- \*1. Use the NX Unit Message Enabled Status 15 object because the number of NX Units is up to 15 Units.
- \*2. Indicates the ASCII code for "prwr". The mode changes to Parameter Write Mode.
- \*3. This value is 5000 + ((Unit No. 4 - 1) × 20), or 5060 hex.
- \*4. This is an NX object of the NX-TS3201.
- \*5. Indicates the ASCII code for "save". The changed parameter setting is saved.
- \*6. Use the NX Unit Message Enabled Status 15 object because the number of NX Units is up to 15 Units.

You must confirm just before you start the operation that the Unit can perform message communications. Refer to *9-3-3 I/O Ports for Status That Accept Device Variable Assignments* on page 9-39 for the confirmation method.

### A-6-3 Unit Operation Settings When Using Index 380F Hex (Store Parameters Command)

This section describes the Unit operation settings when using index 380F hex (Store Parameters Command).

#### CoE Objects to Use

You use the following CoE objects to change Unit operation settings in EtherCAT Coupler Units and NX Units.

Index (hex)	Object name	Reference
3005	NX Unit Message Enabled Status	page A-63

Index (hex)	Object name	Reference
3006	NX Unit I/O Data Active Status	page A-64
380B	Switch Parameter Write Mode	page A-71
380E	NX Unit Restart	page A-73
380F	Store Parameters Command	page A-74
5000 + ((NX Unit No. - 01) × 20)	The object name depends on the specifications of the NX Unit.	page A-80

## Unit Operation Setting Procedure

Use the following procedure to set NX Unit operation settings with a master from another manufacturer.

- 1** Use index 3005 hex (NX Unit Message Enabled Status) to confirm that message communications are enabled for the Unit for which to set the Unit operation settings.
- 2** Use index 380B hex (Switch Parameter Write Mode) to change the Unit to Parameter Write Mode.
- 3** Change the CoE object for the Unit operation settings to change in the Unit.
- 4** Use index 380F hex (Store Parameters Command) to save the parameters of the Unit.
- 5** Use index 380F hex (Store Parameters Command) to confirm that the parameters have been saved successfully.  
 If saving was successful, go to step 6.  
 If saving failed, replace the Unit or take other corrective measures.  
 If the parameters are still being saved, return to step 4.
- 6** Use index 380E hex (NX Unit Restart) to restart the Unit.
- 7** Use index 3006 hex (NX Unit I/O Data Active Status) to confirm that the Unit is performing I/O data communications.

**A**

## Example for Unit Operation Settings

The following example shows setting Unit operation settings for an EtherCAT Coupler Unit and NX Unit with a master from another manufacturer.

The conditions are given in the following table.

Item	Description
Unit	NX-TS3201
Unit Number	4
Unit operation settings	The <i>Channel 1 Enable/Disable</i> object (index 5000 hex and subindex 01 hex) is set to <i>disable</i> (FALSE).

The procedure is given in the following table.

Step	Accessed CoE object			Processing
	Index (hex)	Subindex (hex)	Object name	
1	3005	---	NX Unit Message Enabled Status	Confirm that the value of bit 4 is TRUE because the unit number of the Unit is 4.
		01	NX Unit Message Enabled Status 15* <sup>1</sup>	
2	380B	---	Switch Parameter Write Mode	Write a value of 50525752 hex.* <sup>2</sup>
		04	Switch Parameter Write Mode NX Unit 4	
3	5060* <sup>3</sup>	---	---	Write a value of FALSE.
		01	Channel Enable/Disable* <sup>4</sup>	
4	380F	---	Store Parameters Command	Write a value of 73613034.* <sup>5</sup>
		01	Store Parameters Command	
5	380F	---	Store Parameters Command	Confirm the value.* <sup>6</sup>
		02	Store Parameters Status	
6	380E	---	NX Unit Restart	Write a value of 0000 hex.
		04	NX Unit 4 Restart	
7	3006	---	NX Unit I/O Data Active Status	Confirm that the value of bit 4 is TRUE because the unit number of the Unit is 4.
		01	NX Unit I/O Data Active Status 15* <sup>7</sup>	

\*1. Use the NX Unit Message Enabled Status 15 object because the number of NX Units is up to 15 Units.

\*2. Indicates the ASCII code for "prwr". The mode changes to Parameter Write Mode.

\*3. This value is 5000 + ((Unit No. 4 - 1) × 20), or 5060 hex.

\*4. This is an NX object of the NX-TS3201.

\*5. The unit number of the Unit is 4, so the value of the lower four digits is 3034 hex (i.e., the ASCII code for "0" and "4").

\*6. Successful: 00 hex, Failure: 02 hex, In progress: FF hex.

\*7. Use the NX Unit Message Enabled Status 15 object because the number of NX Units is up to 15 Units.

You must confirm just before you start the operation that the Unit can perform message communications. Refer to *9-3-3 I/O Ports for Status That Accept Device Variable Assignments* on page 9-39 for the confirmation method.

## A-6-4 Unit Operation Settings When Using Index 1011 Hex (Restore Default Parameters)

This section describes the Unit operation settings when using index 1011 hex (Restore Default Parameters).

### CoE Objects to Use

The following CoE objects are used to set Unit operation settings in NX Units.

Index (hex)	Object name	Reference
1011	Restore Default Parameters	page A-37
3005	NX Unit Message Enabled Status	page A-63
3006	NX Unit I/O Data Active Status	page A-64
380B	Switch Parameter Write Mode	page A-71
380E	NX Unit Restart	page A-73

## Unit Operation Setting Procedure

Use the following procedure to set NX Unit operation settings with a master from another manufacturer.

- 1** Use index 3005 hex (NX Unit Message Enabled Status) to confirm that message communications are enabled for the Unit for which to set the Unit operation settings.
- 2** Use index 380B hex (Switch Parameter Write Mode) to change the Unit to Parameter Write Mode.
- 3** Use index 1011 hex (Restore Default Parameters) to initialize the parameters of the Unit.
- 4** Use index 380E hex (NX Unit Restart) to restart the Unit.
- 5** Use index 3006 hex (NX Unit I/O Data Active Status) to confirm that the Unit is performing I/O data communications.

## Example for Unit Operation Settings

The following example shows setting Unit operation settings for an EtherCAT Coupler Unit and NX Unit with a master from another manufacturer.

The conditions are given in the following table.

Item	Description
Unit	NX-TS3201
Unit Number	4
Unit operation settings	Initialize the parameters.

The procedure is given in the following table.

Step	Accessed CoE object			Processing
	Index (hex)	Sub-index (hex)	Object name	
1	3005	---	NX Unit Message Enabled Status	Confirm that the value of bit 4 is TRUE because the unit number of the Unit is 4.
		01	NX Unit Message Enabled Status 15* <sup>1</sup>	
2	380B	---	Switch Parameter Write Mode	Write a value of 50525752 hex.* <sup>2</sup>
		04	Switch Parameter Write Mode NX Unit 4	
3	1011	---	Restore Default Parameters	Write a value of 6C6F6164 hex.* <sup>3</sup>
		05	Restore NX Unit 4 Default Parameters	
4	380E	---	NX Unit Restart	Write a value of 0000 hex.
		04	NX Unit 4 Restart	

**A**

Step	Accessed CoE object			Processing
	Index (hex)	Subindex (hex)	Object name	
5	3006	---	NX Unit I/O Data Active Status	Confirm that the value of bit 4 is TRUE because the unit number of the Unit is 4.
		01	NX Unit I/O Data Active Status 15*4	

- \*1. Use the NX Unit Message Enabled Status 15 object because the number of NX Units is up to 15 Units.
- \*2. Indicates the ASCII code for "prwr". The mode changes to Parameter Write Mode.
- \*3. Indicates the ASCII code for "load". The parameters are initialized.
- \*4. Use the NX Unit Message Enabled Status 15 object because the number of NX Units is up to 15 Units.

You must confirm just before you start the operation that the Unit can perform message communications. Refer to *9-3-3 I/O Ports for Status That Accept Device Variable Assignments* on page 9-39 for the confirmation method.

### A-6-5 Unit Operation Settings When Using Index 3810 Hex (Restore Default Parameters Command)

This section describes the Unit operation settings when using index 3810 hex (Restore Default Parameters Command).

#### CoE Objects to Use

You use the following CoE objects to change Unit operation settings in EtherCAT Coupler Units and NX Units.

Index (hex)	Object name	Reference
3005	NX Unit Message Enabled Status	page A-63
3006	NX Unit I/O Data Active Status	page A-64
380B	Switch Parameter Write Mode	page A-71
380E	NX Unit Restart	page A-73
3810	Restore Default Parameters Command	page A-76

#### Unit Operation Setting Procedure

Use the following procedure to set NX Unit operation settings with a master from another manufacturer.

- 1** Use index 3005 hex (NX Unit Message Enabled Status) to confirm that message communications are enabled for the Unit for which to set the Unit operation settings.
- 2** Use index 380B hex (Switch Parameter Write Mode) to change the Unit to Parameter Write Mode.
- 3** Use index 3810 hex (Restore Default Parameters Command) to initialize the parameters of the Unit.

- 4** Use index 3810 hex (Restore Default Parameters Command) to confirm that the parameters have been saved successfully.  
 If saving was successful, go to step 5.  
 If saving failed, replace the Unit or take other corrective measures.  
 If the parameters are still being saved, return to step 3.
- 5** Use index 380E hex (NX Unit Restart) to restart the Unit.
- 6** Use index 3006 hex (NX Unit I/O Data Active Status) to confirm that the Unit is performing I/O data communications.

## Example for Unit Operation Settings

The following example shows setting Unit operation settings for an EtherCAT Coupler Unit and NX Unit with a master from another manufacturer.  
 The conditions are given in the following table.

Item	Description
Unit	NX-TS3201
Unit Number	4
Unit operation settings	Initialize the parameters.

The procedure is given in the following table.

Step	Accessed CoE object			Processing
	Index (hex)	Subindex (hex)	Object name	
1	3005	---	NX Unit Message Enabled Status	Confirm that the value of bit 4 is TRUE because the unit number of the Unit is 4.
		01	NX Unit Message Enabled Status 15* <sup>1</sup>	
2	380B	---	Switch Parameter Write Mode	Write a value of 50525752 hex.* <sup>2</sup>
		04	Switch Parameter Write Mode NX Unit 4	
3	3810	---	Restore Default Parameters Command	Write a value of 6C6F3034 hex.* <sup>3</sup>
		01	Restore Default Parameters Command	
4	3810	---	Restore Default Parameters Command	Confirm the value.* <sup>4</sup>
		02	Restore Default Parameters Status	
5	380E	---	NX Unit Restart	Write a value of 0000 hex.
		04	NX Unit 4 Restart	
6	3006	---	NX Unit I/O Data Active Status	Confirm that the value of bit 4 is TRUE because the unit number of the Unit is 4.
		01	NX Unit I/O Data Active Status 15* <sup>5</sup>	

\*1. Use the NX Unit Message Enabled Status 15 object because the number of NX Units is up to 15 Units.

\*2. Indicates the ASCII code for "prwr". The mode changes to Parameter Write Mode.

- \*3. The unit number of the Unit is 4, so the value of the lower four digits is 3034 hex (i.e., the ASCII code for "0" and "4").
- \*4. Successful: 00 hex, Failure: 02 hex, In progress: FF hex.
- \*5. Use the NX Unit Message Enabled Status 15 object because the number of NX Units is up to 15 Units.

You must confirm just before you start the operation that the Unit can perform message communications. Refer to *9-3-3 I/O Ports for Status That Accept Device Variable Assignments* on page 9-39 for the confirmation method.

# A-7 CoE Objects

This section explains the CoE objects that are implemented by the EtherCAT Coupler Unit.



## Precautions for Safe Use

Always sufficiently check the safety at the connected devices before you change the settings of a slave or Unit.

## A-7-1 Object Dictionary Area

The CAN application protocol over EtherCAT (CoE) is based on the object dictionary for the CAN application protocol.

All objects are assigned 4-digit hexadecimal indexes. The objects are structured in the following areas.

Indexes	Area	Description
0000 to 0FFF hex	Data Type Area	This area contains the data type definitions.
1000 to 1FFF hex	CoE Communications Area	The objects in this area are defined for use by all servers that perform specialized communications. <ul style="list-style-type: none"> <li>• PDO mapping objects</li> </ul>
2000 to 2FFF hex	Manufacturer-specific Area 1	The objects in this area are defined for all OMRON products.
3000 to 5FFF hex	Manufacturer-specific Area 2	The objects in this area are defined for the EtherCAT Coupler Unit.
6000 to 9FFF hex	Device Profile Area	The objects in this area are defined by the CiA401 Generic I/O Module Device Profile (a profile that specifies the CAN application protocol interface for devices with digital I/O and analog I/O).
A000 to EFFF hex	Reserved area	This area is reserved for future use.
F000 to FFFF hex	Modular Device-specific Area	The objects in this area are defined by modular devices.

## A-7-2 Data Type

The following data types are used in this profile.

Data type	Abbreviation	Size	Range of values
Boolean	BOOL	1 bit	0 (FALSE) or 1 (TRUE)
Unsigned8	U8	1 byte	0 to 255
Unsigned16	U16	2 bytes	0 to 65,535
Unsigned32	U32	4 bytes	0 to 4,294,967,295
Unsigned64	U64	8 bytes	0 to 18,446,744,073,709,551,615
Visible string	VS	---	---
ARRAY[0..Y] OF BYTE	ARRAY[0..Y] OF BYTE	Y+1 bytes	---

## A-7-3 Assigning Objects

This section describes how objects are assigned in an EtherCAT Slave Terminal.

### Assignment of Objects in an EtherCAT Slave Terminal

The following figure and table show how index numbers for objects are assigned to the EtherCAT Coupler Unit and NX Units in an EtherCAT Slave Terminal.

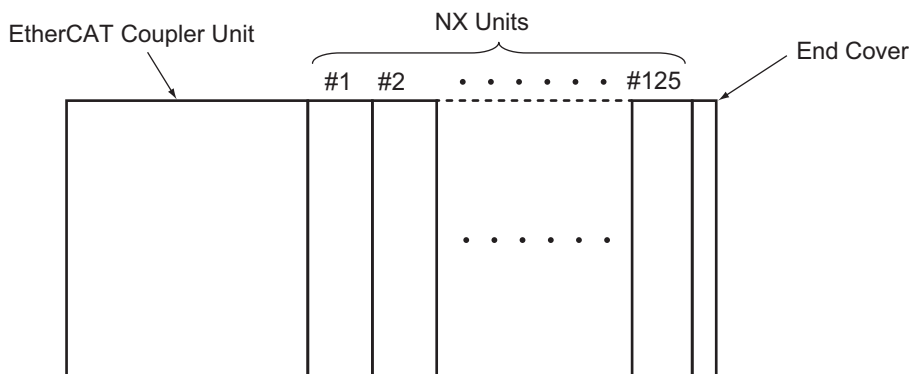

Object type	EtherCAT Coupler Unit	NX Units <sup>*1</sup>			
		#1	#2	---	#125
Input Data Mapping Objects (PDO mapping objects for TxPDOs)	1BF4 hex to 1BFF hex	1A00 hex to 1A03 hex	1A04 hex to 1A07 hex	---	1BF0 hex to 1BF3 hex
Input Data Objects (application objects for TxPDOs)	3000 hex to 5FFF hex	6000 hex to 601F hex	6020 hex to 603F hex	---	6F80 hex to 6F9F hex
Output Data Mapping Objects (PDO mapping objects for RxPDOs)	17F4 hex to 17FF hex	1600 hex to 1603 hex	1604 hex to 1607 hex	---	17F0 hex to 17F3 hex
Output Data Objects (application objects for RxPDOs)		7000 hex to 701F hex	7020 hex to 703F hex	---	7F80 hex to 7F9F hex
Configuration Objects <sup>*2</sup>		8000 hex to 801F hex	8020 hex to 803F hex	---	8F80 hex to 8F9F hex
Information Objects <sup>*3</sup>		9000 hex to 901F hex	9020 hex to 903F hex	---	9F80 hex to 9F9F hex

\*1. #1 to #125 are the NX Unit numbers for the NX Units.  
 \*2. This is an information object for the downloaded Unit configuration.  
 \*3. This is an information object for the actual Unit configuration.

### EtherCAT Coupler Unit Objects

PDO mapping objects (Input Data Mapping Objects and Output Data Mapping Objects) and application objects (Input Data Objects and Output Data Objects) are assigned for the range of index numbers in the table under *Assignment of Objects in an EtherCAT Slave Terminal* on page A-32.

## NX Unit Objects

Each type of objects is assigned to the NX Units for every NX Unit number.

- **PDO Mapping Objects (Input Data Mapping Objects and Output Data Mapping Objects)**

The PDO mapping objects for NX Units have four indexes assigned for every NX Unit number.

To access a PDO mapping object for an NX Unit with SDO communications, specify the index number that is assigned to the NX Unit number of the target NX Unit.

- **Application Objects (Input Data Objects and Output Data Objects)**

Application objects for the NX Units are assigned for every NX Unit number. Specifically, the Input Data Objects and Output Data Objects each have 32 indexes assigned for every NX Unit number. The application objects for NX Units are referenced by NX objects that are defined for each model number. Definitions for NX objects start at unit number 1 (#1).

To access an application object for an NX Unit with SDO communications, specify the index number as follows: shift the index number of the object by subtracting 1 hex from the NX Unit number of the target NX Unit in hex, and then multiply this by 20 hex.

Example: To access the NX object with an index number of 6000 hex and a subindex number of 01 hex on the NX Unit with an NX Unit number of 2:

$(02 \text{ hex} - 01 \text{ hex}) \times 20 \text{ hex} = 20 \text{ hex}$

Shift the index number by 20 hex to get the index number 6020 hex, and specify a subindex number of 01 hex.

- **Configuration Objects and Information Objects**

The configuration objects and information objects for NX Units each have 32 indexes assigned for every NX Unit number.

These objects contain information that describes the Unit configuration, and are defined for each NX Unit model number and product.

Definitions for the configuration objects and information objects start at Unit number 1 (#1).

To access configuration objects and information objects for an NX Unit with SDO communications, specify the index number as follows: shift the index number of the object by subtracting 1 from the NX Unit number of the target NX Unit, and then multiply this by 20 hex.

## A-7-4 Format of Objects

This manual describes objects with the following format.

Index (hex)	Sub-index (hex)	Object name	Default	Data range	Unit	Data attribute	Size	Access	PDO mapping	Complete access
<Index>	<Sub-index>	<Object name>	<Default setting>	<Data range>	<Unit >	<Data attribute>	<Size >	<Access>	<Possible/ Not possible>	<Possible/ Not possible>

Items within the <> brackets are replaced with data. Each item has the following meaning.

Item	Description
Index	This is the index of the object that is expressed as a four-digit hexadecimal number.
Subindex	This is the subindex of the object that is expressed as a two-digit hexadecimal number.
Object name	This is the name of the object. For a subindex, this is the name of the subindex.
Default	This is the value that is set when the product is shipped from the factory.
Data range	For a read-only (RO) object, this is the range of the data that you can read. For a read/write (RW) object, this is the setting range of the data.
Unit	The unit is the physical units.
Data attribute	This is the timing when changes to writable objects are enabled. A: Enabled at all times B: When moving from Pre-Operational state to Safe-Operational state C: When moving from Pre-Operational state to Init state R: When the power supply is reset or the Unit is restarted ---: Write-prohibited
Size	This is the size of the object in bytes.
Access	This data tells if the object is read-only or read/write. RO: Read only RW: Read/write
PDO mapping	This tells whether you can map the object to a PDO.
Complete access*1	This tells whether the object allows complete access.

\*1. Complete access is used to read and write to a batch of objects. It allows you to read or write to all subindexes of an object.

### A-7-5 Communication Objects

Index (hex)	Subindex (hex)	Object name	Default	Data range	Unit	Data attribute	Size	Access	PDO mapping	Complete access
1000	---	Device Type	00001389 hex	00001389 hex	---	---	4 bytes (U32)	RO	Not possible.	Not possible.

- This object gives the CoE device profile number for the EtherCAT Coupler Unit (NX-ECC201, NX-ECC202, or NX-ECC203).

Index (hex)	Subindex (hex)	Object name	Default	Data range	Unit	Data attribute	Size	Access	PDO mapping	Complete access
1008	---	Manufacturer Device Name	---	---	---	---	20 bytes (VS)	RO	Not possible.	Not possible.

- This object gives the model of the EtherCAT Coupler Unit.

Index (hex)	Subindex (hex)	Object name	Default	Data range	Unit	Data attribute	Size	Access	PDO mapping	Complete access
1009	---	Manufacturer Hardware Version	" " (padded with 20 spaces (character 20 hex))	" " (padded with 20 spaces (character 20 hex))	---	---	20 bytes (VS)	RO	Not possible.	Not possible.

- This object gives the hardware version of the EtherCAT Coupler Unit.

Index (hex)	Subindex (hex)	Object name	Default	Data range	Unit	Data attribute	Size	Access	PDO mapping	Complete access
100 A	---	Manufacturer Software Version	---	---	---	---	20 bytes (VS)	RO	Not possible.	Not possible.

- This object gives the software version of the EtherCAT Coupler Unit.

Index (hex)	Subindex (hex)	Object name	Default	Data range	Unit	Data attribute	Size	Access	PDO mapping	Complete access
1010	---	Store Parameters	---	---	---	---	---	---	---	Not possible.
	00	Number of entries	*1	*1	---	---	1 byte (U8)	RO	Not possible.	---
	01	Store Parameters	00000001 hex	00000000 to FFFFFFFF hex	---	R	4 bytes (U32)	RW	Not possible.	---
	03*2	Store Slave Terminal Parameters	00000001 hex	00000000 to 65766173 hex	---	R	4 bytes (U32)	RW	Not possible.	---
	04*2	Store NX Unit 1 Parameters	00000001 hex	00000000 to 65766173 hex	---	R	4 bytes (U32)	RW	Not possible.	---
	...*2	...	...	...	...	...	...	...	...	...
	42*2	Store NX Unit 63 Parameters	00000001 hex	00000000 to 65766173 hex	---	R	4 bytes (U32)	RW	Not possible.	---

\*1. This value is 42 hex for NX-ECC203 version 1.5 or later. Otherwise, it is 01 hex.

\*2. These subindexes can be used with NX-ECC203 version 1.5 or later.

- This object is used to save parameters.
- Subindex 01 hex is used to save parameters for the EtherCAT Coupler Unit.
- Subindex 03 hex is used to save the parameters for all Units in the EtherCAT Slave Terminal.
- You can also save the parameters for individual NX Units. For subindexes 04 hex to 42 hex, the number in the object name indicates the NX Unit number and each subindex corresponds to the Store Parameters object for the relevant NX Unit.
- To prevent inadvertently saving parameters, the parameters are saved only when you write a specific value to subindex 01 hex.

The designated value means "save".

MSB		LSB	
e	v	a	s
65 hex	76 hex	61 hex	73 hex

If you write a value other than the designated value, the abort code is returned.

- When saving the parameters is completed, an SDO response is returned to the EtherCAT master.
- No response is returned until saving the parameters is completed.
- The saved parameter values are applied when you restart the Unit after you execute this object.
- During a read, the object gives 00000001 hex (command enabled).
- If you execute index 380F hex during execution of index 1010 hex, the abort code is returned.
- You cannot use this object to save parameters for Safety CPU Units and Safety I/O Units. If you specify a Safety CPU Unit or Safety I/O Unit, the abort code is returned.
- If a Unit Configuration Verification Error occurs, the abort code is returned.

Index (hex)	Subindex (hex)	Object name	Default	Data range	Unit	Data attribute	Size	Access	PDO mapping	Complete access
1011	---	Restore Default Parameters	---	---	---	---	---	---	---	Not possible.
	00	Number of entries	01 hex	01 hex	---	---	1 byte (U8)	RO	Not possible.	---
	01	Restore Default Parameters	00000001 hex	00000000 to FFFFFFFF hex	---	R	4 bytes (U32)	RW	Not possible.	---
	02*1	Restore NX Unit 1 Default Parameters	00000001 hex	00000000 to 64616F6C hex	---	R	4 bytes (U32)	RW	Not possible.	---
	...	...	...	...	...	...	...	...	...	...
	40*1	Restore NX Unit 63 Default Parameters	00000001 hex	00000000 to 64616F6C hex	---	R	4 bytes (U32)	RW	Not possible.	---

\*1. This subindex can be used with NX-ECC203 version 1.5 or later.

- This object returns the parameters to their default values.
- Subindex 01 hex initializes the parameters for all Units in the EtherCAT Slave Terminal.
- You can also initialize the parameters for individual NX Units. For subindexes 02 hex to 40 hex, the number in the object name indicates the NX Unit number and each subindex corresponds to the Restore Default Parameters object for the relevant NX Unit.
- To prevent inadvertently restoring parameters, the parameters are restored only when you write a specific value to subindex 01 hex.

The designated value means "load".

MSB		LSB	
d	a	o	l
64 hex	61 hex	6F hex	6C hex

If you write a value other than the designated value, the abort code is returned.

- No response is returned until initializing the parameters is completed.
- The initialized parameter values are applied when you restart the Unit after you execute this object.
- During a read, the object gives 00000001 hex (command enabled).
- You cannot initialize Safety CPU Unit parameters. If you specify a Safety CPU Unit, the abort code is returned.
- If a Unit Configuration Verification Error occurs, the abort code is returned.

Index (hex)	Subindex (hex)	Object name	Default	Data range	Unit	Data attribute	Size	Access	PDO mapping	Complete access
1018	---	Identity Object	---	---	---	---	---	---	---	Possible.
	00	Number of entries	04 hex	04 hex	---	---	1 byte (U8)	RO	Not possible.	---
	01	Vendor ID	00000083 hex	00000083 hex	---	---	4 bytes (U32)	RO	Not possible.	---
	02	Product Code	---	---	---	---	4 bytes (U32)	RO	Not possible.	---
	03	Revision Number	---	---	---	---	4 bytes (U32)	RO	Not possible.	---
	04	Serial Number	---	00000000 to FFFFFFFF hex	---	---	4 bytes (U32)	RO	Not possible.	---

- This object gives information on the EtherCAT Coupler Unit.
- Subindex 01 hex gives the vendor's ID.
- Subindex 02 hex gives the value that is assigned to the EtherCAT Coupler Unit.

Model	Default	Data range
NX-ECC201	00000083 hex	00000083 hex
NX-ECC202	000000A6 hex	000000A6 hex
NX-ECC203	000000AA hex	000000AA hex

- Subindex 03 hex gives the revision number of the EtherCAT Coupler Unit.  
 Bits 16 to 31: These bits give the major revision number of the EtherCAT Coupler Unit.  
 Bits 0 to 15: These bits give the minor revision number of the EtherCAT Coupler Unit.
- Subindex 04 hex gives the serial number of the EtherCAT Coupler Unit. This is a unique value for each product.

Index (hex)	Subindex (hex)	Object name	Default	Data range	Unit	Data attribute	Size	Access	PDO mapping	Complete access
10E0	---	Node Address Reload	---	---	---	---	---	---	---	Not possible.
	00	Number of entries	03 hex	03 hex	---	---	1 byte (U8)	RO	Not possible.	---
	01	Configured Station Alias Register Value	0000 hex	0000 to FFFF hex	---	A	2 bytes (U16)	RW	Not possible.	---
	03	ID-Selector validation	0000 hex	0000 to FFFF hex	---	A	2 bytes (U16)	RW	Not possible.	---

- Subindex 01 hex gives the software setting of the node address.

When Writing:

If the hardware switches for the node address are set to 0, the value that you write to this object is the software setting for the node address. (Set the value to write in the ESC register 0012 hex.)

If the hardware switches for the node address are set to a value other than 0, the hardware switches are enabled. This causes an SDO communications error and returns abort code 08000021 hex.

When Reading:

If the hardware switches for the node address are set to 0, the software setting (the value written to the ESC register 0012 hex) is given.

If the hardware switches for the node address are set to a value other than 0, the value set on the hardware switches is given.

- Subindex 03 hex gives the node address that is set on the hardware switches.

When Writing:

If the hardware switches for the node address are set to 0, an SDO communications error occurs and abort code 08000021 hex is returned, regardless of the write value.

If the hardware switches for the node address are set to a value other than 0 and the write value is 0000 hex, the value set on the hardware switches is written to the ESC register 0012 hex.

If the write value is any other value than 0000 hex, an SDO communications error occurs and abort code 08000021 hex is returned.

When Reading:

This gives the value that is set on the hardware switches for the node address.

Index (hex)	Sub-index (hex)	Object name	Default	Data range	Unit	Data attribute	Size	Access	PDO mapping	Complete access
10F3	---	Diagnosis History	---	---	---	---	---	---	---	Possible.
	00	Number of entries	85 hex	85 hex	---	---	1 byte (U8)	RO	Not possible.	---
	01	Maximum Messages	80 hex	80 hex	---	---	1 byte (U8)	RO	Not possible.	---
	02	Newest Message	00 hex	00 hex, 06 to 85 hex	---	---	1 byte (U8)	RO	Not possible.	---
	03*1	Newest Acknowledged Message	00 hex	00 hex, 06 to 85 hex	---	---	1 byte (U8)	RW	Not possible.	---
	04*1	New Messages Available	FALSE	FALSE, TRUE	---	---	1 bit	RO	Possible.	---
	05	Flags	0000 hex	0000 to 0001 hex	---	A	2 bytes (U16)	RW	Not possible.	---
	06	Diagnosis Message 1	---	---	---	---	23 bytes (ARRAY[0..22] OF BYTE)*2	RO	Not possible.	---
	...	...	...	...	...	...	...	...	...	...
	85	Diagnosis Message 128	---	---	---	---	23 bytes (ARRAY[0..22] OF BYTE)*2	RO	Not possible.	---

\*1. These subindexes can be used with NX-ECC203 version 1.5 or later.

\*2. The data type for NX-ECC203 version 1.4 or earlier and models other than the NX-ECC203 is 23 bytes (VS).

- This object gives a maximum of 128 diagnosis messages. This object is used to enable or disable emergency messages.
- Subindex 01 hex (Maximum Messages) gives the number of error messages.
- Subindex 02 (Newest Message) gives the subindex number of the most recent diagnosis message.
- Subindex 03 hex (Newest Acknowledged Message) gives the number of the newest acknowledged message. The operations for reading and writing are different, as described in the following table.

Reading/writing	Operation
Reading	<ul style="list-style-type: none"> <li>• The subindex of the most recent error log record is returned (06 hex to 85 hex).</li> <li>• If there are no records in the error log, 00 hex is returned.</li> </ul>
Writing	<ul style="list-style-type: none"> <li>• Write the number of the error log record between 06 and 85 hex.</li> <li>• The value of subindex 04 hex (Newest Messages Available) changes to FALSE.</li> <li>• If you write 00 hex, the entire error log is cleared.</li> <li>• If you write values other than 00 hex and 06 to 85 hex, the abort code is returned.</li> <li>• If you write a subindex that does not have an error log record, the abort code is returned.</li> </ul>

- Subindex 04 hex (New Messages Available) provides notification of new messages. It indicates if the error log has been updated. When the error log is updated, the value changes to 1 (TRUE). The value changes to 0 (FALSE) in the following cases.
  - a) Subindex 03 hex (Newest Acknowledged Message) gives the subindex number of the most recent error log record.
  - b) The error log has not been updated.
- Subindex 05 hex (Flags) is the control flags for the error logs. Use this to specify whether to use emergency messages to report error messages. Set this to 0001 hex to enable notification, or 0000 hex to disable notification. This is set to 0000 hex (no emergency notifications) when the power supply is turned ON. The error logs are saved for errors where the error log record to be given as saved in *13-7-3 Emergency Error Codes* on page 13-57 even if it is set to disable notification.
- Subindexes 06 to 85 hex give the diagnosis messages (from Diagnosis Message 1 to Diagnosis Message 128).  
 Subindex 06 hex (Diagnosis Message 1) to subindex 85 hex (Diagnosis Message 128) store up to 128 errors as they occur. The 129th error causes the storage of errors to return to subindex 06 hex (Diagnosis Message 1).
- The following table gives the format of a diagnosis message.

Item	Data type	Details
Dialog code	UINT32	Bits 16 to 31: Emergency error code* <sup>1</sup> Bits 0 to 15: E800 hex
Flags	UINT16	0004 hex: Error message
Text ID	UINT16	0000 hex: No text ID
Time Stamp	UINT64	The time that the error occurred.* <sup>2</sup> <sup>3</sup>
Flag parameter 1	UINT16	Bits 12 to 15: 01 hex Bits 0 to 11: 005 hex (size of parameter 1)
Parameter 1	ARRAY[0..4] OF BYTE	Byte 4: NX Unit number Bytes 0 to 3: Event code* <sup>4</sup>

\*1. Refer to *13-7-3 Emergency Error Codes* on page 13-57 for details on the emergency error codes.  
 \*2. If you use a master from another manufacturer and if the event log time has not been set with subindex 10F9 hex (Present Time for Event Log), 0 is stored.  
 \*3. For NX-ECC203 version 1.4 or earlier and models other than the NX-ECC203, 0 is stored.  
 \*4. Refer to *13-3-2 Event Codes for Errors and Troubleshooting Procedures* on page 13-14 for details on event codes for errors.

- The following table provides the procedure to read the error log record. The error indicates one that first occurred after the error log record was cleared. The error log record is written to subindex 06 hex (Diagnosis Message 1).

Step	User program processing in the EtherCAT master	Processing in the EtherCAT Coupler Unit
1	Monitor the value of subindex 04 hex (New Messages Available).	---
2	---	<ul style="list-style-type: none"> <li>• Write the error log record to subindex 06 hex (Diagnosis Message 1) when an error occurs.</li> <li>• The value of subindex 04 hex (New Messages Available) changes from FALSE to TRUE.</li> </ul>
3	<ul style="list-style-type: none"> <li>• Detect that the value of subindex 04 hex (New Messages Available) changed to TRUE.</li> <li>• Read the value of subindex 06 hex (Diagnosis Message 1).</li> <li>• Write the number of the error log record 06 hex that was read to subindex 03 hex (Newest Acknowledged Message).</li> </ul>	---
4	---	<ul style="list-style-type: none"> <li>• Detect that the value of subindex 03 hex (Newest Acknowledged Message) was changed.</li> <li>• The value of subindex 04 hex (New Messages Available) changes from TRUE to FALSE.</li> </ul>

Index (hex)	Subindex (hex)	Object name	Default	Data range	Unit	Data attribute	Size	Access	PDO mapping	Complete access
10F9*1	---	Present Time for Event Log	---	---	---	---	---	---	---	Possible.
	00	Number of entries	01 hex	01 hex	---	---	1 byte (U8)	RO	Not possible.	---
	01	Present Time for Event Log	000000000 0000000 hex	000000000000000 000 to 2FFFFFFFFF FFFF hex	ns	---	8 bytes (U64)	RW	Not possible.	---

\*1. This object can be used with NX-ECC203 version 1.5 or later.

- This object is used to set the present time for the event log.
- The time information is indicated in a relative time from 1970/1/1, 0:00:00. The unit is seconds.
- An addition of time is started from the set value.
- You do not need to use this object for the NJ/NX-series CPU Units and NY-series Industrial PCs. The time information in the CPU Unit or Industrial PC is used to record times in the event log.
- If you use a master from another manufacturer and if this object was not used to set the event log time, the times recorded in the event log will all be 1970/1/1, 0:00:00.

## A-7-6 PDO Mapping Objects

The PDO mapping objects for the EtherCAT Slave Terminal are listed in the following table.

Index (hex)	Description
1600 to 17F3	Receive PDO mappings for NX Units
1A00 to 1BF3	Transmit PDO mappings for NX Units
17F4 to 17FF	Receive PDO mappings for the EtherCAT Coupler Unit
1BF4 to 1BFF	Transmit PDO mappings for the EtherCAT Coupler Unit

Refer to *A-7-3 Assigning Objects* on page A-32 for the PDO mapping objects and application objects that are mapped to the EtherCAT Slave Terminal.

Subindexes 01 hex and on give the mapped application object information.

31	16 15	8 7	0
Index	Subindex	Bit length	
MSB			LSB

Bits 16 to 31: Index of the assigned object

Bits 8 to 15: Subindex of the assigned object

Bits 0 to 7: Bit length of the assigned object (i.e., a bit length of 32 bits is given as 20 hex)

## Receive PDO Mapping Objects for NX Units

The indexes from 1600 to 17F3 hex are for receive PDO mapping objects for NX Units.

Index (hex)	Subindex (hex)	Object name	Default	Data range	Unit	Data attribute	Size	Access	PDO mapping	Complete access
1600 to 1603	---	1st - 4th receive PDO Mapping	---	---	---	---	---	---	---	Possible.
	00	Number of objects in this PDO	Depends on Unit.	00 to FF hex	---	Depends on Unit.	1 byte (U8)	Depends on Unit.	Not possible.	---
	01 to FF	1st - 255th Output Object to be mapped	Depends on Unit.	00000000 to FFFFFFFF hex	---	Depends on Unit.	4 bytes (U32)	Depends on Unit.	Not possible.	---
1604 to 1607	---	5th - 8th receive PDO Mapping	---	---	---	---	---	---	---	Possible.
	00	Number of objects in this PDO	Depends on Unit.	00 to FF hex	---	Depends on Unit.	1 byte (U8)	Depends on Unit.	Not possible.	---
	01 to FF	1st - 255th Output Object to be mapped	Depends on Unit.	00000000 to FFFFFFFF hex	---	Depends on Unit.	4 bytes (U32)	Depends on Unit.	Not possible.	---
...	...	...	...	...	...	...	...	...	...	
17F0 to 17F3	---	496th - 500th receive PDO Mapping	---	---	---	---	---	---	---	Possible.
	00	Number of objects in this PDO	Depends on Unit.	00 to FF hex	---	Depends on Unit.	1 byte (U8)	Depends on Unit.	Not possible.	---
	01 to FF	1st - 255th Output Object to be mapped	Depends on Unit.	00000000 to FFFFFFFF hex	---	Depends on Unit.	4 bytes (U32)	Depends on Unit.	Not possible.	---

- For every NX Unit, four indexes are assigned in order from NX Unit number 1, as shown in the following table.

Index (hex)	Object name	Assignment
1600 to 1603	1st - 4th receive PDO Mapping	For the NX Unit with NX Unit number 1
1604 to 1607	5th - 8th receive PDO Mapping	For the NX Unit with NX Unit number 2
...	...	...
17F0 to 17F3	496th - 500th receive PDO Mapping	For the NX Unit with NX Unit number 125

- The above table of receive PDO mapping objects for an NX Unit are intentionally described in a simplified format.

The actual assignments for a single NX Unit are as follows:

Example: NX Unit Number 1

Index (hex)	Subindex (hex)	Object name
1600	---	1st receive PDO Mapping
	00	Number of objects in this PDO
	01	1st Output Object to be mapped
	---	---
	FF	255th Output Object to be mapped
1601	---	2nd receive PDO Mapping
	00	Number of objects in this PDO
	01	1st Output Object to be mapped
	---	---
	FF	255th Output Object to be mapped
1602	---	3rd receive PDO Mapping
	00	Number of objects in this PDO
	01	1st Output Object to be mapped
	---	---
	FF	255th Output Object to be mapped
1603	---	4th receive PDO Mapping
	00	Number of objects in this PDO
	01	1st Output Object to be mapped
	---	---
	FF	255th Output Object to be mapped

- The application objects that are assigned to the PDO mapping objects are defined for each NX Unit model. Application objects are linked to NX objects.

The following table gives an example of PDO mappings for an actual NX Unit.

Example: An NX-OD3121 Four-point Output Unit or NX-OD5121 Sixteen-point Output Unit is connected to NX Unit number 1.

Index (hex)	Subindex (hex)	Object name	Default	
			NX-OD3121	NX-OD5121
1600	---	1st receive PDO Mapping	---	---
	00	Number of objects in this PDO	04 hex	01 hex
	01	1st Output Object to be mapped	70000101 hex	70020110 hex
	02	2nd Output Object to be mapped	70000201 hex	---
	03	3rd Output Object to be mapped	70000301 hex	---
	04	4th Output Object to be mapped	70000401 hex	---
	---	---	---	---
	FF	255th Output Object to be mapped	---	---
1601	---	2nd receive PDO Mapping	---	---
	00	Number of objects in this PDO	---	---
	01	1st Output Object to be mapped	---	---
	---	---	---	---
	FF	255th Output Object to be mapped	---	---

Index (hex)	Subindex (hex)	Object name	Default	
			NX-OD3121	NX-OD5121
1602	---	3rd receive PDO Mapping	---	---
	00	Number of objects in this PDO	---	---
	01	1st Output Object to be mapped	---	---
	---	---	---	---
	FF	255th Output Object to be mapped	---	---
1603	---	4th receive PDO Mapping	---	---
	00	Number of objects in this PDO	---	---
	01	1st Output Object to be mapped	---	---
	---	---	---	---
	FF	255th Output Object to be mapped	---	---

Refer to the user's manuals for the NX Units for details on NX objects which serve as application objects for the NX Units.

Index (hex)	Subindex (hex)	Object name	Default	Data range	Unit	Data attribute	Size	Access	PDO mapping	Complete access
17F4	---	501st receive PDO Mapping	---	---	---	---	---	---	---	Possible.
	00	Number of objects in this PDO	01 hex	01 hex	---	---	1 byte (U8)	RO	Not possible.	---
	01	1st Output Object to be mapped	00000000 hex	00000000 to 00000010 hex	---	B	4 bytes (U32)	RW	Not possible.	---

- This object sets the padding data for the Coupler PDO group.

Index (hex)	Subindex (hex)	Object name	Default	Data range	Unit	Data attribute	Size	Access	PDO mapping	Complete access
17F5	---	502nd receive PDO Mapping	---	---	---	---	---	---	---	Possible.
	00	Number of objects in this PDO	01 hex	01 hex	---	---	1 byte (U8)	RO	Not possible.	---
	01	1st Output Object to be mapped	00000000 hex	00000000 to 00000010 hex	---	B	4 bytes (U32)	RW	Not possible.	---

- This object sets the padding data for the word PDO group.

Index (hex)	Sub-index (hex)	Object name	Default	Data range	Unit	Data attribute	Size	Access	PDO mapping	Complete access
17F6	---	503rd receive PDO Mapping	---	---	---	---	---	---	---	Possible.
	00	Number of objects in this PDO	01 hex	01 hex	---	---	1 byte (U8)	RO	Not possible.	---
	01	1st Output Object to be mapped	00000000 hex	00000000 to 00000010 hex	---	B	4 bytes (U32)	RW	Not possible.	---

- This object sets the padding data for the bit PDO group.

Index (hex)	Sub-index (hex)	Object name	Default	Data range	Unit	Data attribute	Size	Access	PDO mapping	Complete access
17F7	---	504th receive PDO Mapping	---	---	---	---	---	---	---	Possible.
	00	Number of objects in this PDO	01 hex	01 hex	---	---	1 byte (U8)	RO	Not possible.	---
	01	1st Output Object to be mapped	00000000 hex	00000000 to 00000010 hex	---	B	4 bytes (U32)	RW	Not possible.	---

- This object sets the padding data for the safety PDO group.

## Transmit PDO Mapping Objects for NX Units

The indexes from 1A00 to 1BF3 hex are for transmit PDO mapping objects for NX Units.

Index (hex)	Sub-index (hex)	Object name	Default	Data range	Unit	Data attribute	Size	Access	PDO mapping	Complete access
1A00 to 1A03	---	1st - 4th transmit PDO Mapping	---	---	---	---	---	---	---	Possible.
	00	Number of objects in this PDO	Depends on Unit.	00 to FF hex	---	Depends on Unit.	1 byte (U8)	Depends on Unit.	Not possible.	---
	01 to FF	1st - 255th Input Object to be mapped	Depends on Unit.	00000000 to FFFFFFFF hex	---	Depends on Unit.	4 bytes (U32)	Depends on Unit.	Not possible.	---
1A04 to 01A07	---	5th - 8th transmit PDO Mapping	---	---	---	---	---	---	---	Possible.
	00	Number of objects in this PDO	Depends on Unit.	00 to FF hex	---	Depends on Unit.	1 byte (U8)	Depends on Unit.	Not possible.	---
	01 to FF	1st - 255th Input Object to be mapped	Depends on Unit.	00000000 to FFFFFFFF hex	---	Depends on Unit.	4 bytes (U32)	Depends on Unit.	Not possible.	---

Index (hex)	Subindex (hex)	Object name	Default	Data range	Unit	Data attribute	Size	Access	PDO mapping	Complete access
---	---	---	---	---	---	---	---	---	---	---
1BF0 to 1BF3	---	496th - 500th transmit PDO Mapping	---	---	---	---	---	---	---	Possible.
	00	Number of objects in this PDO	Depends on Unit.	00 to FF hex	---	Depends on Unit.	1 byte (U8)	Depends on Unit.	Not possible.	---
	01 to FF	1st - 255th Input Object to be mapped	Depends on Unit.	00000000 to FFFFFFFF hex	---	Depends on Unit.	4 bytes (U32)	Depends on Unit.	Not possible.	---

- For every NX Unit, four indexes are assigned in order from NX Unit number 1, as shown in the following table.

Index (hex)	Object name	Assignment
1A00 to 1A03	1st - 4th transmit PDO Mapping	For the NX Unit with NX Unit number 1
1A04 to 1A07	5th - 8th transmit PDO Mapping	For the NX Unit with NX Unit number 2
---	---	---
1BF0 to 1BF3	496th - 500th transmit PDO Mapping	For the NX Unit with NX Unit number 125

- The above table of transmit PDO mapping objects for an NX Unit are intentionally described in a simplified format.

The actual assignments for a single NX Unit are as follows:

Example: NX Unit Number 1

Index (hex)	Subindex (hex)	Object name
1A00	---	1st transmit PDO Mapping
	00	Number of objects in this PDO
	01	1st Input Object to be mapped
	---	---
	FF	255th Input Object to be mapped
1A01	---	2nd transmit PDO Mapping
	00	Number of objects in this PDO
	01	1st Input Object to be mapped
	---	---
	FF	255th Input Object to be mapped
1A02	---	3rd transmit PDO Mapping
	00	Number of objects in this PDO
	01	1st Input Object to be mapped
	---	---
	FF	255th Input Object to be mapped
1A03	---	4th transmit PDO Mapping
	00	Number of objects in this PDO
	01	1st Input Object to be mapped
	---	---
	FF	255th Input Object to be mapped

- The application objects that are assigned to the PDO mapping objects are defined for each NX Unit model. Application objects are linked to NX objects.

The following table gives an example of PDO mappings for an actual NX Unit.

Example: An NX-ID3317 Four-point Input Unit or NX-TS2101 Two-point Temperature Input Unit is connected to NX Unit number 1.

Index (hex)	Subindex (hex)	Object name	Default	
			NX-ID3317	NX-TS2101
1A00	---	1st transmit PDO Mapping	---	---
	00	Number of objects in this PDO	04 hex	02 hex
	01	1st Input Object to be mapped	60000101 hex	60010110 hex
	02	2nd Input Object to be mapped	60000201 hex	60010210 hex
	03	3rd Input Object to be mapped	60000301 hex	---
	04	4th Input Object to be mapped	60000401 hex	---
	---	---	---	---
	FF	255th Input Object to be mapped	---	---
1A01	---	2nd transmit PDO Mapping	---	---
	00	Number of objects in this PDO	---	---
	01	1st Input Object to be mapped	---	---
	02	2nd Input Object to be mapped	---	---
	---	---	---	---
	FF	255th Input Object to be mapped	---	---
1A02	---	3rd transmit PDO Mapping	---	---
	00	Number of objects in this PDO	---	---
	01	1st Input Object to be mapped	---	---
	02	2nd Input Object to be mapped	---	---
	---	---	---	---
	FF	255th Input Object to be mapped	---	---
1A03	---	4th transmit PDO Mapping	---	---
	00	Number of objects in this PDO	---	---
	01	1st Input Object to be mapped	---	---
	---	---	---	---
	FF	255th Input Object to be mapped	---	---

Refer to the user's manuals for the NX Units for details on NX objects which serve as application objects for the NX Units.

## PDO Mapping Objects for the EtherCAT Coupler Unit

The indexes from 1BF4 to 1BFF hex are for transmit PDO mapping objects for the EtherCAT Coupler Unit.

Index (hex)	Sub-index (hex)	Object name	Default	Data range	Unit	Data attribute	Size	Access	PDO mapping	Complete access
1BF4	---	501st transmit PDO Mapping	---	---	---	---	---	---	---	Possible.
	00	Number of objects in this PDO	01 hex	01 hex	---	---	1 byte (U8)	RO	Not possible.	---
	01	1st Input Object to be mapped	00000000 hex	00000000 to 00000010 hex	---	B	4 bytes (U32)	RW	Not possible.	---

- This object sets the padding data for the Coupler PDO group.

Index (hex)	Sub-index (hex)	Object name	Default	Data range	Unit	Data attribute	Size	Access	PDO mapping	Complete access
1BF5	---	502nd transmit PDO Mapping	---	---	---	---	---	---	---	Possible.
	00	Number of objects in this PDO	01 hex	01 hex	---	---	1 byte (U8)	RO	Not possible.	---
	01	1st Input Object to be mapped	00000000 hex	00000000 to 00000010 hex	---	B	4 bytes (U32)	RW	Not possible.	---

- This object sets the padding data for the word PDO group.

Index (hex)	Sub-index (hex)	Object name	Default	Data range	Unit	Data attribute	Size	Access	PDO mapping	Complete access
1BF6	---	503rd transmit PDO Mapping	---	---	---	---	---	---	---	Possible.
	00	Number of objects in this PDO	01 hex	01 hex	---	---	1 byte (U8)	RO	Not possible.	---
	01	1st Input Object to be mapped	00000000 hex	00000000 to 00000010 hex	---	B	4 bytes (U32)	RW	Not possible.	---

- This object sets the padding data for the bit PDO group.

Index (hex)	Sub-index (hex)	Object name	Default	Data range	Unit	Data attribute	Size	Access	PDO mapping	Complete access
1BF7	---	504th transmit PDO Mapping	---	---	---	---	---	---	---	Possible.
	00	Number of objects in this PDO	01 hex	01 hex	---	---	1 byte (U8)	RO	Not possible.	---
	01	1st Input Object to be mapped	00000000 hex	00000000 to 00000010 hex	---	B	4 bytes (U32)	RW	Not possible.	---

- This object sets the padding data for the word PDO group.

Index (hex)	Subindex (hex)	Object name	Default	Data range	Unit	Data attribute	Size	Access	PDO mapping	Complete access
1BF8	---	505th transmit PDO Mapping	---	---	---	---	---	---	---	Possible.
	00	Number of objects in this PDO	02 hex	00 to 06 hex	---	B	1 byte (U8)	RW	Not possible.	---
	01	1st Input Object to be mapped	*1	*1	---	B	4 bytes (U32)	RW	Not possible.	---
	02	2nd Input Object to be mapped	*1		---	B	4 bytes (U32)	RW	Not possible.	---
	03	3rd Input Object to be mapped	00000000 hex		---	B	4 bytes (U32)	RW	Not possible.	---
	04	4th Input Object to be mapped	00000000 hex		---	B	4 bytes (U32)	RW	Not possible.	---
	05	5th Input Object to be mapped	00000000 hex		---	B	4 bytes (U32)	RW	Not possible.	---
	06	6th Input Object to be mapped	00000000 hex		---	B	4 bytes (U32)	RW	Not possible.	---

\*1. The default for each model and the application objects that you can map are listed.

Data range	Object name (application object)	Remarks
30030110 hex	NX Unit Registration Status 15	---
30030220 hex	NX Unit Registration Status 31	---
30030340 hex	NX Unit Registration Status 63	With the NX-ECC203, this is assigned to subindex 01 hex by default.
30030480 hex	NX Unit Registration Status 125	With the NX-ECC201 or NX-ECC202, this is assigned to subindex 01 hex by default.
30050110 hex	NX Unit Message Enabled Status 15	---
30050220 hex	NX Unit Message Enabled Status 31	---
30050340 hex	NX Unit Message Enabled Status 63	---
30050480 hex	NX Unit Message Enabled Status 125	---
30060110 hex	NX Unit I/O Data Active Status 15	---
30060220 hex	NX Unit I/O Data Active Status 31	---
30060340 hex	NX Unit I/O Data Active Status 63	With the NX-ECC203, this is assigned to subindex 02 hex by default.
30060480 hex	NX Unit I/O Data Active Status 125	With the NX-ECC201 or NX-ECC202, this is assigned to subindex 02 hex by default.
30070110 hex	NX Unit Error Status 15	---
30070220 hex	NX Unit Error Status 31	---
30070340 hex	NX Unit Error Status 63	---
30070480 hex	NX Unit Error Status 125	---
300A0140 hex	Timestamp of synchronous input	---
300A0240 hex	Timestamp of synchronous output	---

- These objects are PDO mapping objects that allow the addition or deletion of application objects. You can map application objects such as the status information for the EtherCAT Slave Terminal, EtherCAT Coupler Unit, or NX Units.

Refer to *A-7-9 Manufacturer-specific Object 2* on page A-61 for details on these application objects.

Index (hex)	Subindex (hex)	Object name	Default	Data range	Unit	Data attribute	Size	Access	PDO mapping	Complete access
1BFE*1	---	511th transmit PDO Mapping	---	---	---	---	---	---	---	Possible.
	00	Number of objects in this PDO	02 hex	00 to 02 hex	---	---	1 byte (U8)	RO	Not possible.	---
	01	1st Input Object to be mapped	10F30401 hex	10F30401 hex	---	---	4 bytes (U32)	RO	Not possible.	---
	02	2nd Input Object to be mapped	0000000F hex	0000000F hex	---	---	4 bytes (U32)	RO	Not possible.	---

\*1. This object can be used with NX-ECC203 version 1.5 or later.

- This object is a PDO mapping object that is used to report whether the error log is updated. You cannot add or delete application objects.
- The new messages available of index 10F3 hex, subindex 04 hex is mapped to subindex 01 hex (1st Input Object to be mapped).
- Refer to *Diagnosis History* on page A-40 for details on index 10F3 hex.
- Subindex 02 hex (2nd Input Object to be mapped) is the padding data.

Index (hex)	Subindex (hex)	Object name	Default	Data range	Unit	Data attribute	Size	Access	PDO mapping	Complete access
1BFF	---	512th transmit PDO Mapping	---	---	---	---	---	---	---	Possible.
	00	Number of objects in this PDO	01 hex	01 hex	---	---	1 byte (U8)	RO	Not possible.	Possible.
	01	1st Input Object to be mapped	20020108 hex	20020108 hex	---	---	4 bytes (U32)	RO	Not possible.	Possible.

- This object is a PDO mapping object that is used to report that the EtherCAT Slave Terminal detected an error. You cannot add or delete application objects.
- The Sysmac error status is mapped to index 2002 hex, subindex 01 hex.
- If the EtherCAT Coupler Unit is connected to the built-in EtherCAT port on an NJ/NX-series CPU Unit or NY-series Industrial PC, this object is assigned to the Sync Manager 3 PDO Assignment object (1C13 hex). This object is assigned automatically in the default Sysmac Studio settings.

## A-7-7 Sync Manager Communications Objects

The EtherCAT communications memory is set with objects from 1C00 to 1C13 hex.

Index (hex)	Subindex (hex)	Object name	Default	Data range	Unit	Data attribute	Size	Access	PDO mapping	Complete access
1C00	---	Sync Manager Communication Type	---	---	---	---	---	---	---	Possible.
	00	Number of used SM channels	04 hex	04 hex	---	---	1 byte (U8)	RO	Not possible.	---
	01	Communication Type Sync Manager 0	01 hex	01 hex	---	---	1 byte (U8)	RO	Not possible.	---
	02	Communication Type Sync Manager 1	02 hex	02 hex	---	---	1 byte (U8)	RO	Not possible.	---
	03	Communication Type Sync Manager 2	03 hex	03 hex	---	---	1 byte (U8)	RO	Not possible.	---
	04	Communication Type Sync Manager 3	04 hex	04 hex	---	---	1 byte (U8)	RO	Not possible.	---

- The Sync Managers are set as follows:  
 SM0: Mailbox receive (EtherCAT master to an EtherCAT Slave Terminal)  
 SM1: Mailbox send (EtherCAT Slave Terminal to EtherCAT master)  
 SM2: Process data output (EtherCAT master to EtherCAT Slave Terminal)  
 SM3: Process data input (EtherCAT Slave Terminal to EtherCAT master)

Index (hex)	Subindex (hex)	Object name	Default	Data range	Unit	Data attribute	Size	Access	PDO mapping	Complete access
1C10	---	Sync Manager 0 PDO Assignment	---	---	---	---	---	---	---	Possible.
	00	Number of assigned PDOs	00 hex	00 hex	---	---	1 byte (U8)	RO	Not possible.	---

- This object gives the number of PDO mappings that are used by Sync Manager 0.
- The number of PDO mappings that are used by Sync Manager 0 are always 00 hex. In other words, the Mailbox Receive Sync Manager does not have any PDOs.

Index (hex)	Subindex (hex)	Object name	Default	Data range	Unit	Data attribute	Size	Access	PDO mapping	Complete access
1C11	---	Sync Manager 1 PDO Assignment	---	---	---	---	---	---	---	Possible.
	00	Number of assigned PDOs	00 hex	00 hex	---	---	1 byte (U8)	RO	Not possible.	---

- This object gives the number of PDO mappings that are used by Sync Manager 1.
- The number of PDO mappings that are used by Sync Manager 1 are always 00 hex. In other words, the Mailbox Transmit Sync Manager does not have any PDOs.

Index (hex)	Subindex (hex)	Object name	Default	Data range	Unit	Data attribute	Size	Access	PDO mapping	Complete access
1C12	---	Sync Manager 2 PDO Assignment	---	---	---	---	---	---	---	Possible.
	00	Number of assigned RxPDOs	00 hex	00 to FF hex	---	B	1 byte (U8)	RW*1	Not possible.	---
	01 to FF	1st - 255th PDO Mapping object index of assigned PDO	Depends on configuration.	0000 hex, 1600 to 17F7 hex	---	B	2 bytes (U16)	RW*1	Not possible.	---

\*1. This is set to RO if the object does not have a receive PDO.

- This object gives the receive PDO that is used by Sync Manager 2.
- There can be a maximum of 255 PDO mappings in the range of indexes from 1600 to 17F7 hex.
- The default value depends on the Unit configuration. The default value is 0000 hex for NX Units that are not mounted.

Index (hex)	Subindex (hex)	Object name	Default	Data range	Unit	Data attribute	Size	Access	PDO mapping	Complete access
1C13	---	Sync Manager 3 PDO Assignment	---	---	---	---	---	---	---	Possible.
	00	Number of assigned TxPDOs	00 hex	00 to FF hex	---	B	1 byte (U8)	RW*1	Not possible.	---
	01 to FF	1st - 255th PDO Mapping object index of assigned PDO	Depends on configuration.	0000 hex, 1A00 to 1BFF hex	---	B	2 bytes (U16)	RW*1	Not possible.	---

\*1. This is set to RO if the object does not have a transmit PDO.

- This gives the transmit PDO that is used by the Sync Manager.
- There can be a maximum of 255 PDO mappings in the range of indexes from 1A00 to 1BFF hex.
- The default value depends on the Unit configuration. The default values are 1BF4, 1BF8, and 1BFF hex for NX Units that are not mounted.

Index (hex)	Subindex (hex)	Object name	Default	Data range	Unit	Data attribute	Size	Access	PDO mapping	Complete access
1C32	---	Sync Manager 2 Synchronization	---	---	---	---	---	---	---	Possible.
	00	Number of Synchronization Parameters	*1	*1	---	---	1 byte (U8)	RO	Not possible.	---
	01	Synchronization Type	0000 hex	0000 or 0002 hex	---	B	2 bytes (U16)	RW	Not possible.	---
	02	Cycle Time	00000000 hex	00000000 to FFFFFFFF hex	ns	---	4 bytes (U32)	RO	Not possible.	---
	03	Shift Time	Depends on configuration.	00000000 to FFFFFFFF hex	ns	B	4 bytes (U32)	RW	Not possible.	---
	04	Synchronization Types supported	0005 hex	0005 hex	---	---	2 bytes (U16)	RO	Not possible.	---
	05	Minimum Cycle Time	00000000 hex	00000000 to FFFFFFFF hex	ns	---	4 bytes (U32)	RO	Not possible.	---
	06	Calc and Copy Time	00000000 hex	00000000 to FFFFFFFF hex	ns	---	4 bytes (U32)	RO	Not possible.	---
	09	Delay Time	00000000 hex	00000000 to FFFFFFFF hex	ns	---	4 bytes (U32)	RO	Not possible.	---
	0B*2	Cycle Time Too Small	00000000 hex	00000000 to FFFFFFFF hex	Number of times	---	4 bytes (U32)	RO	Not possible.	---
	0C*2	Cycle Time Too Small	0000 hex	0000 to FFFF hex	Number of times	---	2 bytes (U16)	RO	Not possible.	---

\*1. The values vary depending on the Unit version of the EtherCAT Coupler Unit. See below.

Unit version 1.5 or earlier: 0B hex

Unit version 1.6 or later: 0C hex

\*2. The subindex number of Cycle Time Too Small varies depending on the Unit version of the EtherCAT Coupler Unit. See below.

Unit version 1.5 or earlier: 0B hex

Unit version 1.6 or later: 0C hex

- This object gives the specifications of the EtherCAT communications mode for Sync Manager 2.
- Subindex 01 hex gives the EtherCAT communications mode that you can select for Sync Manager 2 of the EtherCAT Coupler Unit.
  - 0000 hex: Free-Run Mode
  - 0002 hex: DC Mode (Sync0)

This mode is synchronized with the Sync0 event.
- Subindex 02 hex gives the cycle time.
  - In Free-Run Mode, the time between two local timer events is given.
  - In DC Mode (Sync0), the synchronization cycle of Sync0 is given.
- Subindex 03 hex gives the shift time of the EtherCAT Slave Terminal.
  - By setting the shift time, the time from Sync0 until the NX Unit output synchronization timing can be increased by the result of the following calculation.

*Set value of the Shift Time – Delay Time (hardware delay time)*

When you do not set the shift time, it is the same as the hardware delay time.

The shift time is valid only in DC Mode when the Unit configuration information is registered. When moving from Init state to Pre-Operational (Pre-Op) state, the shift time is initialized.

- Subindex 04 hex gives the type of synchronization that is supported by the EtherCAT Coupler Unit. Free-Run Mode and DC Mode (Sync0) are supported.
- Subindex 05 hex gives the minimum cycle time that is supported by the EtherCAT Slave Terminal.
- Subindex 06 hex gives the amount of time it will take for the EtherCAT Slave Terminal to process the process data.
- Subindex 09 hex gives the hardware delay time of the EtherCAT Slave Terminal.
- Subindexes 0B hex and 0C hex give the value of the error counter in the EtherCAT Slave Terminal. This counter is incremented if processing in the EtherCAT Slave Terminal is not completed within the synchronization cycle.

Index (hex)	Subindex (hex)	Object name	Default	Data range	Unit	Data attribute	Size	Access	PDO mapping	Complete access
1C33	---	Sync Manager 3 Synchronization	---	---	---	---	---	---	---	Possible.
	00	Number of Synchronization Parameters	*1	*1	---	---	1 byte (U8)	RO	Not possible.	---
	01	Synchronization Type	0000 hex	0000 or 0002 hex	---	B	2 bytes (U16)	RW	Not possible.	---
	02	Cycle Time	00000000 hex	00000000 to FFFFFFFF hex	ns	---	4 bytes (U32)	RO	Not possible.	---
	03	Shift Time	Depends on configuration.	00000000 to FFFFFFFF hex	ns	B	4 bytes (U32)	RW	Not possible.	---
	04	Synchronization Types supported	0005 hex	0005 hex	---	---	2 bytes (U16)	RO	Not possible.	---
	05	Minimum Cycle Time	00000000 hex	00000000 to FFFFFFFF hex	ns	---	4 bytes (U32)	RO	Not possible.	---
	06	Calc and Copy Time	00000000 hex	00000000 to FFFFFFFF hex	ns	---	4 bytes (U32)	RO	Not possible.	---
	0B <sup>*2</sup>	Cycle Time Too Small	00000000 hex	00000000 to FFFFFFFF hex	Number of times	---	4 bytes (U32)	RO	Not possible.	---
	0C <sup>*2</sup>	Cycle Time Too Small	0000 hex	0000 to FFFF hex	Number of times	---	2 bytes (U16)	RO	Not possible.	---

\*1. The values vary depending on the Unit version of the EtherCAT Coupler Unit. See below.

Unit version 1.5 or earlier: 0B hex

Unit version 1.6 or later: 0C hex

\*2. The subindex number of Cycle Time Too Small varies depending on the Unit version of the EtherCAT Coupler Unit. See below.

Unit version 1.5 or earlier: 0B hex

Unit version 1.6 or later: 0C hex

- This object gives the specifications of the EtherCAT communications mode for Sync Manager 3.
- Subindex 01 hex gives the EtherCAT communications mode that you can select for Sync Manager 3 of the EtherCAT Coupler Unit.

0000 hex: Free-Run Mode

0002 hex: DC Mode (Sync0)

This mode is synchronized with the Sync0 event.

- Subindex 02 hex gives the cycle time.

In Free-Run Mode, the time between two local timer events is given.

In DC Mode (Sync0), the synchronization cycle of Sync0 is given.

- Subindex 03 hex gives the shift time of the EtherCAT Slave Terminal.

By setting the shift time, the time from Sync0 until the NX Unit input synchronization timing can be increased.

When you do not set the shift time, it is the same as the Delay Time (09 hex) in Sync Manager 2 Synchronization (1C32 hex).

The shift time is valid only in DC Mode when the Unit configuration information is registered. When moving from Init state to Pre-Operational (Pre-Op) state, the shift time is initialized.

- Subindex 04 hex gives the type of synchronization that is supported by the EtherCAT Coupler Unit. Free-Run Mode and DC Mode (Sync0) are supported.
- Subindex 05 hex gives the minimum cycle time that is supported by the EtherCAT Slave Terminal.
- Subindex 06 hex gives the amount of time it will take for the EtherCAT Slave Terminal to process the process data.
- Subindexes 0B hex and 0C hex give the value of the error counter in the EtherCAT Slave Terminal. This counter is incremented if processing in the EtherCAT Slave Terminal is not completed within the synchronization cycle.

**A**

**A-7-8 Manufacturer-specific Object 1**

Index (hex)	Subindex (hex)	Object name	Default	Data range	Unit	Data attribute	Size	Access	PDO mapping	Complete access
2002	---	Sysmac Error	---	---	---	---	---	---	---	Not possible.
	00	Number of entries	02 hex	02 hex	---	---	1 byte (U8)	RO	Not possible.	---
	01	Sysmac Error Status	02 hex	00 to FF hex	---	---	1 byte (U8)	RO	Possible.	---
	02	Sysmac Error Status Clear	00 hex	00 to FF hex	---	A	1 byte (U8)	RW	Not possible.	---

- This object gives the Sysmac error status for the EtherCAT Slave Terminal.
- The assignments of bits in the Sysmac error status at subindex 01 hex are listed below. The applicable bit is 0 (FALSE) if no error exists, or 1 (TRUE) if an error exists. Bit 1 is always 1 (TRUE). Bit 1 does not indicate an error.

Bits 6 to 7: Reserved

Bit 5: Minor Fault

Bit 4: Observation

Bits 2 to 3: Reserved

Bit 1: Reserved

Bit 0: Reserved

Refer to *Details of I/O Data in the EtherCAT Coupler Unit* on page 9-19 for details on the Sysmac error status.

- Subindex 02 hex is used to clear the Sysmac Error Status.  
Write 01 hex to clear the Sysmac Error Status. If you write a value other than 01 hex, the command is invalid and the abort code is returned.  
When a read is performed, 00 hex is given.

Index (hex)	Sub-index (hex)	Object name	Default	Data range	Unit	Data attribute	Size	Access	PDO mapping	Complete access
2003	---	Sysmac Observation	---	---	---	---	---	---	---	Possible.
	00	Number of Observation	00 hex	00 to 80 hex	---	---	1 byte (U8)	RO	Not possible.	---
	01	Observation 1	---	---	---	---	12 bytes (ARRAY[0..11] OF BYTE)*1	RO	Not possible.	---
	---	---	---	---	---	---	---	---	---	---
	80	Observation 128	---	---	---	---	12 bytes (ARRAY[0..11] OF BYTE)*1	RO	Not possible.	---

\*1. The data type for NX-ECC203 version 1.4 or earlier is 12 bytes (VS).

- This object gives *observation*-level Controller events that are detected by the EtherCAT Slave Terminal.
- Subindex 00 hex gives the number of observations that are detected by the EtherCAT Slave Terminal.
- Subindexes 01 to 80 hex give the error logs for up to 128 observations that currently exist. The combined total number of logs for observations and minor faults (2004 hex) that are detected by the EtherCAT Slave Terminal is 128. If a minor fault is detected when there are a total of 128 observations and minor faults combined, the log for the most recent observation is deleted and the new minor fault is added. If an observation is detected when there are 128 logs for observations, the record for the most recent observation is deleted.
- Observations are stored in the order that they occur from subindexes 01 to 80 hex.
- The logs are cleared when TRUE is written to the Sysmac Error Status Clear (02 hex) in the Sysmac Error (2002 hex).
- The following table gives the format of each log.

Item	Data type	Details
Error code	UINT32	Event code (stored in little endian)
Type of error detail	UINT32	Bytes 2 to 3: 0007 hex (an unsigned 32-bit integer that gives the data type) Byte 1: 0004 hex (size of detail data) Byte 0: 10 hex (detail data exists)
Error detail	UINT32	Detail data (NX Unit number where the observation occurred)

Refer to *13-3-2 Event Codes for Errors and Troubleshooting Procedures* on page 13-14 for the event codes.

Index (hex)	Sub-index (hex)	Object name	Default	Data range	Unit	Data attribute	Size	Access	PDO mapping	Complete access
2004	---	Sysmac Minor Fault	---	---	---	---	---	---	---	Possible.
	00	Number of Minor Fault	00 hex	00 to 80 hex	---	---	1 byte (U8)	RO	Not possible.	---
	01	Minor Fault 1	---	---	---	---	12 bytes (AR-RAY[0..11] OF BYTE)*1	RO	Not possible.	---
	---	---	---	---	---	---	---	---	---	---
	80	Minor Fault 128	---	---	---	---	12 bytes (AR-RAY[0..11] OF BYTE)*1	RO	Not possible.	---

\*1. The data type for NX-ECC203 version 1.4 or earlier is 12 bytes (VS).

- This object gives *minor fault*-level Controller events that are detected by the EtherCAT Slave Terminal.
- Subindex 00 hex gives the number of *minor fault*-level Controller events that are detected by the EtherCAT Slave Terminal.
- Subindexes 01 to 80 hex give the error logs for up to 128 minor faults that currently exist. The combined total number of logs for minor faults and observations (2003 hex) that are detected by the EtherCAT Slave Terminal is 128. If a minor fault is detected when there are a total of 128 minor faults and observations combined, the log for the most recent observation is deleted and the new minor fault is added. If a minor fault is detected when there are a total of 128 events for minor faults, the 129th event is not recorded.
- Minor faults are stored in the order that they occur from subindexes 01 to 80 hex.
- The logs are cleared when TRUE is written to the Sysmac Error Status Clear (02 hex) in the Sysmac Error (2002 hex).
- The following table gives the format of each log.

Item	Data type	Details
Error code	UINT32	Event code (stored in little endian)
Type of error detail	UINT32	Bytes 2 to 3: 0007 hex (an unsigned 32-bit integer that gives the data type) Byte 1: 0004 hex (size of detail data) Byte 0: 10 hex (detail data exists)
Error detail	UINT32	Detail data (NX Unit number where the minor fault occurred)

Refer to 13-3-2 *Event Codes for Errors and Troubleshooting Procedures* on page 13-14 for the event codes.

Index (hex)	Sub-index (hex)	Object name	Default	Data range	Unit	Data attribute	Size	Access	PDO mapping	Complete access
2100	---	Error History Clear	00000000 hex	00000000 to FFFFFFFF hex	---	A	4 bytes (U32)	RW	Not possible.	Not possible.

- This object is used to clear the diagnosis messages in the Diagnosis History (10F3 hex). The diagnosis messages are cleared only when you write a specific value. The designated value means "elcl".

MSB	LSB
l	e
6C hex	65 hex

If you write a value other than the ones given, the result is invalid and the abort code is returned.

Index (hex)	Sub-index (hex)	Object name	Default	Data range	Unit	Data attribute	Size	Access	PDO mapping	Complete access
2200	---	Communications Error Setting	01 hex	00 to 0F hex	Number of times	B	1 byte (U8)	RW	Not possible.	Not possible.

- This object is implemented only for slaves that operate in DC Mode.
- Set this object to the number of consecutive errors to use to detect a communications error.
- The data range is from 00 to 0F hex, and the consecutive error count is equal to the *set value* + 1.
- Although the value can be changed during operation in DC Mode, operation is performed with the value that was set when Pre-Operational state changes to Safe-Operation state. If you read the value, the value that was last written is read.
- With the default value of 01 hex, a communications error will occur if two errors are detected consecutively.



### Precautions for Safe Use

When you use an NJ/NX-series CPU Unit with the cable redundancy function in DC Mode, set the Communications Error Setting set value for EtherCAT slaves in DC Mode to the following value. If the communications cable is disconnected or the power supply of the EtherCAT slaves is turned OFF with the Communications Error Setting set value set to any other value, communications may discontinue due to a Communications Synchronization Error.

Project unit version 1.42 or later: 2 or higher

Project unit version earlier than 1.42: 1 (default value) or higher

Index (hex)	Sub-index (hex)	Object name	Default	Data range	Unit	Data attribute	Size	Access	PDO mapping	Complete access
2201	---	Sync Not Received Timeout Setting	0000 hex	0000 to 0258 hex	s	B	2 bytes (U16)	RW	Not possible.	Not possible.

- This object is implemented only for slaves that operate in DC Mode.
- This object sets the standby time to wait for the first synchronization interrupt signal (Sync0) to enter after moving to Safe-Operational state (when DC mode operation is confirmed).
- If the first interrupt signal (Sync0) is not received within the time set here, a Synchronization Error will occur.
- The data range is from 0000 to 0258 hex (600 s). A set value of 0000 hex allows a wait time of 120 s.
- Although the value can be changed during operation in DC Mode, operation is performed with the value that was set when Pre-Operational state changes to Safe-Operation state. If you read the value, the value that was last written is read.

## A-7-9 Manufacturer-specific Object 2

Index (hex)	Sub-index (hex)	Object name	Default	Data range	Unit	Data attribute	Size	Access	PDO mapping	Complete access
3001	---	Coupler Unit Sysmac Error Status	---	---	---	---	---	---	---	Not possible.
	00	Number of entries	01 hex	01 hex	---	---	1 byte (U8)	RO	Not possible.	---
	01	Coupler Unit Sysmac Error Status	0002 hex	0002 to FFFF hex	---	---	2 bytes (U16)	RO	Not possible.	---

- This object gives the Sysmac error status for the EtherCAT Coupler Unit.
- The assignments of bits in the Sysmac error status for the Coupler Unit at subindex 01 hex are listed below. The applicable bit is 0 (FALSE) if no error exists, or 1 (TRUE) if an error exists. Bit 1 is always 1 (TRUE). Bit 1 does not indicate an error.  
 Bits 6 to 15: Reserved  
 Bit 5: Minor Fault  
 Bit 4: Observation  
 Bits 0 to 3: Reserved
- Each bit is updated at the following times.  
 0 (FALSE) to 1 (TRUE): When an error occurs.  
 1 (TRUE) to 0 (FALSE): When error is reset. Even if the cause of the error has been removed, you must reset the error for the status to change to 0 (FALSE).

Index (hex)	Sub-index (hex)	Object name	Default	Data range	Unit	Data attribute	Size	Access	PDO mapping	Complete access
3002	---	NX Unit Sysmac Error Status	---	---	---	---	---	---	---	Possible.
	00	Number of entries	7D hex	7D hex	---	---	1 byte (U8)	RO	Not possible.	---
	01	NX Unit Sysmac Error Status 1	0000 hex	0000 to FFFF hex	---	---	2 bytes (U16)	RO	Not possible.	---
	---	---	---	---	---	---	---	---	---	---
	7D	NX Unit Sysmac Error Status 125	0000 hex	0000 to FFFF hex	---	---	2 bytes (U16)	RO	Not possible.	---

- This object gives the Sysmac error status for the NX Units.
- Subindexes 01 to 7D hex give the Sysmac error status of each NX Unit from NX Unit number 1 to 125. The bit assignments are listed below. The applicable bit is 0 (FALSE) if no error exists, or 1 (TRUE) if an error exists.  
 Bits 6 to 15: Reserved  
 Bit 5: Minor Fault  
 Bit 4: Observation  
 Bits 0 to 3: Reserved

- Each bit is updated at the following times.  
 0 (FALSE) to 1 (TRUE): When an error occurs.  
 1 (TRUE) to 0 (FALSE): When error is reset. Even if the cause of the error has been removed, you must reset the error for the status to change to 0 (FALSE).

Index (hex)	Subindex (hex)	Object name	Default	Data range	Unit	Data attribute	Size	Access	PDO mapping	Complete access
3003	---	NX Unit Registration Status	---	---	---	---	---	---	---	Not possible.
	00	Number of entries	04 hex	04 hex	---	---	1 byte (U8)	RO	Not possible.	---
	01	NX Unit Registration Status 15	0000 hex	0000 to FFFF hex	---	---	ARRAY [0..1] OF BYTE	RO	Possible.	---
	02	NX Unit Registration Status 31	00000000 hex	00000000 to FFFFFFFF hex	---	---	ARRAY [0..3] OF BYTE	RO	Possible.	---
	03	NX Unit Registration Status 63	0000000000000000 hex	0000000000000000 to FFFFFFFF hex	---	---	ARRAY [0..7] OF BYTE	RO	Possible.	---
	04	NX Unit Registration Status 125	000000000000000000000000 hex	000000000000000000000000 to 3FFFFFFFFFFFFFFFFF hex	---	---	ARRAY [0..15] OF BYTE	RO	Possible.	---

- This object tells whether NX Units are registered in the Unit configuration information.
- The number shown at the end of each object name for subindexes 01 to 04 hex gives the number of NX Units for which the status is acquired. The data assignments are given in the following table. The number in each cell is the NX Unit number of the corresponding NX Unit. NX Unit number 0 represents the EtherCAT Coupler Unit.

The applicable bit is 0 (FALSE) if the Unit is not registered, or 1 (TRUE) if it is registered. NX Units that are set to *Disable* are given as being registered.

Word offset	Bit position															
	15	14	13	12	11	10	09	08	07	06	05	04	03	02	01	00
+0	15	14	13	12	11	10	9	8	7	6	5	4	3	2	1	0
+1	31	30	29	28	27	26	25	24	23	22	21	20	19	18	17	16
+2	47	46	45	44	43	42	41	40	39	38	37	36	35	34	33	32
+3	63	62	61	60	59	58	57	56	55	54	53	52	51	50	49	48
+4	79	78	77	76	75	74	73	72	71	70	69	68	67	66	65	64
+5	95	94	93	92	91	90	89	88	87	86	85	84	83	82	81	80
+6	111	110	109	108	107	106	105	104	103	102	101	100	99	98	97	96
+7			125	124	123	122	121	120	119	118	117	116	115	114	113	112

Refer to NX Unit Registration Status under *Details of I/O Data in the EtherCAT Coupler Unit* on page 9-19 for details on this status.

Index (hex)	Sub-index (hex)	Object name	Default	Data range	Unit	Data attribute	Size	Access	PDO mapping	Complete access
3005	---	NX Unit Message Enabled Status	---	---	---	---	---	---	---	Not possible.
	00	Number of entries	04 hex	04 hex	---	---	1 byte (U8)	RO	Not possible.	---
	01	NX Unit Message Enabled Status 15	0000 hex	0000 to FFFF hex	---	---	ARRAY [0..1] OF BYTE	RO	Possible.	---
	02	NX Unit Message Enabled Status 31	00000000 hex	00000000 to FFFFFFFF hex	---	---	ARRAY [0..3] OF BYTE	RO	Possible.	---
	03	NX Unit Message Enabled Status 63	00000000 00000000 hex	0000000000000000 000 to FFFFFFFF hex	---	---	ARRAY [0..7] OF BYTE	RO	Possible.	---
	04	NX Unit Message Enabled Status 125	00000000 00000000 00000000 00000 hex	0000000000000000 0000000000000000 000000 to 3FFFFFFF hex	---	---	ARRAY [0..15] OF BYTE	RO	Possible.	---

- This object tells whether message communications are enabled for the NX Units.
  - The number shown at the end of each object name for subindexes 01 to 04 hex gives the number of NX Units for which the status is acquired. The data assignments are given in the following table. The number in each cell is the NX Unit number of the corresponding NX Unit. NX Unit number 0 represents the EtherCAT Coupler Unit.
- The applicable bit is 0 (FALSE) if message communications are disabled, or 1 (TRUE) if message communications are enabled.

Message communications are disabled for NX Units that are set to *Disable*.

Word offset	Bit position															
	15	14	13	12	11	10	09	08	07	06	05	04	03	02	01	00
+0	15	14	13	12	11	10	9	8	7	6	5	4	3	2	1	0
+1	31	30	29	28	27	26	25	24	23	22	21	20	19	18	17	16
+2	47	46	45	44	43	42	41	40	39	38	37	36	35	34	33	32
+3	63	62	61	60	59	58	57	56	55	54	53	52	51	50	49	48
+4	79	78	77	76	75	74	73	72	71	70	69	68	67	66	65	64
+5	95	94	93	92	91	90	89	88	87	86	85	84	83	82	81	80
+6	111	110	109	108	107	106	105	104	103	102	101	100	99	98	97	96
+7			125	124	123	122	121	120	119	118	117	116	115	114	113	112

Refer to NX Unit Message Enabled Status under *Details of I/O Data in the EtherCAT Coupler Unit* on page 9-19 for details on this status.

Index (hex)	Sub-index (hex)	Object name	Default	Data range	Unit	Data attribute	Size	Access	PDO mapping	Complete access
3006	---	NX Unit I/O Data Active Status	---	---	---	---	---	---	---	Not possible.
	00	Number of entries	04 hex	04 hex	---	---	1 byte (U8)	RO	Not possible.	---
	01	NX Unit I/O Data Active Status 15	0000 hex	0000 to FFFF hex	---	---	ARRAY [0..1] OF BYTE	RO	Possible.	---
	02	NX Unit I/O Data Active Status 31	00000000 hex	00000000 to FFFFFFFF hex	---	---	ARRAY [0..3] OF BYTE	RO	Possible.	---
	03	NX Unit I/O Data Active Status 63	000000000 00000000 hex	0000000000000 0000 to FFFFFFFFFFFFFF FFFF hex	---	---	ARRAY [0..7] OF BYTE	RO	Possible.	---
	04	NX Unit I/O Data Active Status 125	000000000 000000000 000000000 000000 hex	0000000000000 0000000000000 0000000 to 3FFFFFFFFF FFFFFFFF FFFFFFF hex	---	---	ARRAY [0..15] OF BYTE	RO	Possible.	---

- This object tells whether I/O data can be used for data communications of NX Units.
- The number shown at the end of each object name for subindexes 01 to 04 hex gives the number of NX Units for which the status is acquired. The data assignments are given in the following table. The number in each cell is the NX Unit number of the corresponding NX Unit. NX Unit number 0 represents the EtherCAT Coupler Unit.

The bit is FALSE if the I/O data of the applicable NX Unit cannot be used for control, and TRUE if it can be used. I/O data from NX Units that are set to *Disable* cannot be used for control.

Word offset	Bit position															
	15	14	13	12	11	10	09	08	07	06	05	04	03	02	01	00
+0	15	14	13	12	11	10	9	8	7	6	5	4	3	2	1	0
+1	31	30	29	28	27	26	25	24	23	22	21	20	19	18	17	16
+2	47	46	45	44	43	42	41	40	39	38	37	36	35	34	33	32
+3	63	62	61	60	59	58	57	56	55	54	53	52	51	50	49	48
+4	79	78	77	76	75	74	73	72	71	70	69	68	67	66	65	64
+5	95	94	93	92	91	90	89	88	87	86	85	84	83	82	81	80
+6	111	110	109	108	107	106	105	104	103	102	101	100	99	98	97	96
+7			125	124	123	122	121	120	119	118	117	116	115	114	113	112

Refer to *NX Unit I/O Data Active Status* on page 9-21 for details on this status.

Index (hex)	Sub-index (hex)	Object name	Default	Data range	Unit	Data attribute	Size	Access	PDO mapping	Complete access
3007	---	NX Unit Error Status	---	---	---	---	---	---	---	Not possible.
	00	Number of entries	04 hex	04 hex	---	---	1 byte (U8)	RO	Not possible.	---
	01	NX Unit Error Status 15	0000 hex	0000 to FFFF hex	---	---	ARRAY [0..1] OF BYTE	RO	Possible.	---
	02	NX Unit Error Status 31	00000000 hex	00000000 to FFFFFFFF hex	---	---	ARRAY [0..3] OF BYTE	RO	Possible.	---
	03	NX Unit Error Status 63	00000000 00000000 hex	000000000000 000 to FFFFFFFF hex	---	---	ARRAY [0..7] OF BYTE	RO	Possible.	---
	04	NX Unit Error Status 125	00000000 00000000 00000000 00000 hex	000000000000 000000000000 000000000000 to 3FFFFFFFFF FFFFFFFF hex	---	---	ARRAY [0..15] OF BYTE	RO	Possible.	---

- This object tells whether errors exist in the NX Units.
  - The number shown at the end of each object name for subindexes 01 to 04 hex gives the number of NX Units for which the status is acquired. The data assignments are given in the following table. The number in each cell is the NX Unit number of the corresponding NX Unit. NX Unit number 0 represents the EtherCAT Coupler Unit.
- The applicable bit is 0 (FALSE) if no error exists, or 1 (TRUE) if an error exists.

Word offset	Bit position															
	15	14	13	12	11	10	09	08	07	06	05	04	03	02	01	00
+0	15	14	13	12	11	10	9	8	7	6	5	4	3	2	1	0
+1	31	30	29	28	27	26	25	24	23	22	21	20	19	18	17	16
+2	47	46	45	44	43	42	41	40	39	38	37	36	35	34	33	32
+3	63	62	61	60	59	58	57	56	55	54	53	52	51	50	49	48
+4	79	78	77	76	75	74	73	72	71	70	69	68	67	66	65	64
+5	95	94	93	92	91	90	89	88	87	86	85	84	83	82	81	80
+6	111	110	109	108	107	106	105	104	103	102	101	100	99	98	97	96
+7			125	124	123	122	121	120	119	118	117	116	115	114	113	112

Refer to NX Unit Error Status under *Details of I/O Data in the EtherCAT Coupler Unit* on page 9-19 for details on this status.

Index (hex)	Sub-index (hex)	Object name	Default	Data range	Unit	Data attribute	Size	Access	PDO mapping	Complete access
300A	---	Timestamp of Synchronous IO Refresh	---	---	---	---	---	---	---	Not possible.
	00	Number of entries	02 hex	02 hex	---	---	1 byte (U8)	RO	Not possible.	---
	01	Timestamp of synchronous input	00000000 00000000 hex	000000000000 000 to FFFFFFFFFFFF FFFF hex	ns	---	8 bytes (U64)	RO	Possible.	---
	02	Timestamp of synchronous output	00000000 00000000 hex	000000000000 000 to FFFFFFFFFFFF FFFF hex	ns	---	8 bytes (U64)	RO	Possible.	---

- This object gives the time stamps for when synchronous I/O refreshing was processed.
- Subindex 01 hex gives the time stamp for when the NX Unit performed synchronous inputs.
- Subindex 02 hex gives the time stamp for when the NX Unit performed synchronous outputs.

Index (hex)	Sub-index (hex)	Object name	Default	Data range	Unit	Data attribute	Size	Access	PDO mapping	Complete access
3802	---	NX Unit Configuration	---	---	---	---	---	---	---	Not possible.
	00	Number of entries	04 hex	04 hex	---	---	1 byte (U8)	RO	Not possible.	---
	01	NX Unit Configuration set	0000 hex	0000 to 0001 hex	---	R	2 bytes (U16)	RW	Not possible.	---
	04	NX Unit Serial Number Verification Setting	0000 hex	0000 to 0001 hex	---	R	2 bytes (U16)	RW	Not possible.	---

- This object gives the management function of the configuration information for the EtherCAT Slave Terminal.
- Subindex 01 hex tells whether the configuration information is set as confirmed or cancelled. The configuration information consists of the Unit configuration information and I/O allocation information.  
If the subindex is set to cancel, all of memory is cleared, a restart is executed, and the Unit configuration information is created automatically. This means the physical Unit configuration information is used, and no Unit configuration information is registered separately.  
If the subindex is set to confirm, a restart is executed and the Unit configuration information is registered automatically.  
0000 hex: Cancel configuration information  
0001 hex: Confirm configuration information
- Subindex 04 hex gives the setting of the serial number check method for NX Units. If this subindex is set to *Setting = Actual* device, the serial numbers of the NX Units are verified at these times: when the power is turned ON and after the EtherCAT Coupler Unit is restarted. The serial numbers

of the NX Units saved in the Unit configuration information are compared with the actual device numbers of the NX Units.

0000 hex: No check

0001 hex: Setting = Actual device

Index (hex)	Subindex (hex)	Object name	Default	Data range	Unit	Data attribute	Size	Access	PDO mapping	Complete access
3804	---	Error Detection Setting of NX Unit	---	---	---	---	---	---	---	Not possible.
	00	Number of entries	02 hex	02 hex	---	---	1 byte (U8)	RO	Not possible.	---
	02	NX Unit Connection Wait Time	0003 hex	0003 to 00C8 hex	s	R	2 bytes (U16)	RW	Not possible.	---

- This object implements the function with which the EtherCAT Coupler Unit monitors the NX Units.
- Subindex 02 hex gives the time for which the EtherCAT Coupler Unit will wait for the NX Units to be connected. The setting range for the wait time to monitor for a connection is from 3 (default) to 200 s.

Index (hex)	Subindex (hex)	Object name	Default	Data range	Unit	Data attribute	Size	Access	PDO mapping	Complete access
3805	---	Fail-soft Operation Setting	---	---	---	---	---	---	---	Not possible.
	00	Number of entries	01 hex	01 hex	---	---	1 byte (U8)	RO	Not possible.	---
	01	Fail-soft Operation Setting	01 hex	00 or 01 hex	---	R	1 byte (U8)	RW	Not possible.	---

- This object gives the fail-soft operation setting for the EtherCAT Slave Terminal.
- Fail-soft operation is enabled when 00 hex is written to subindex 01 hex. Write 01 hex to disable fail-soft operation.

Index (hex)	Subindex (hex)	Object name	Default	Data range	Unit	Data attribute	Size	Access	PDO mapping	Complete access
3806	---	Preventing Incorrect Operation Setting	---	---	---	---	---	---	---	Not possible.
	00	Number of entries	01 hex	01 hex	---	---	1 byte (U8)	RO	Not possible.	---
	01	USB Connection Prohibition Setting	00 hex	00 or 01 hex	---	A	1 byte (U8)	RW	Not possible.	---

- This object gives the setting for preventing incorrect operation for the EtherCAT Slave Terminal.

Subindex 01 hex allows you to prohibit Sysmac Studio online connections through the peripheral USB port on the EtherCAT Coupler Unit. Refer to *11-12 Prohibiting USB Connections* on page 11-45 for details on prohibiting a USB connection.

Write *00 hex* to subindex 01 hex to disable prohibiting USB connections and enable the Sysmac Studio to go online. Write *01 hex* to enable prohibiting USB connections and prevent the Sysmac Studio from going online.

Index (hex)	Subindex (hex)	Object name	Default	Data range	Unit	Data attribute	Size	Access	PDO mapping	Complete access
3807	---	Restart	---	---	---	---	---	---	---	Not possible.
	00	Number of entries	0001 hex	0001 hex	---	---	1 byte (U8)	RO	Not possible.	---
	01	Unit Restart	0000 hex	0000 hex	---	A	2 bytes (U16)	RW	Not possible.	---

- This object implements a restart of the EtherCAT Slave Terminal.
- Write *0000 hex* to subindex 01 hex to restart the entire EtherCAT Slave Terminal. If you write a value other than *0000 hex*, the abort code is returned.
- To use this object to restart the EtherCAT Slave Terminal, change the EtherCAT communications state to the Pre-Operational state (Pre-Op) before execution.

Index (hex)	Subindex (hex)	Object name	Default	Data range	Unit	Data attribute	Size	Access	PDO mapping	Complete access
3809	---	Coupler Unit Current Errors	---	---	---	---	---	---	---	Not possible.
	00	Number of entries	01 hex	01 to 21 hex	---	---	1 byte (U8)	RO	Not possible.	---
	01	Update Count	---	---	---	---	2 bytes (U16)	RO	Not possible.	---
	02	Current Error 1	---	---	---	---	50 bytes (ARRAY [0..49] OF BYTE)	RO	Not possible.	---
	---	---	---	---	---	---	---	---	---	---
	21	Current Error 32	---	---	---	---	50 bytes (ARRAY [0..49] OF BYTE)	RO	Not possible.	---

- This object gives the current errors in the EtherCAT Coupler Unit.
- Subindex 00 hex gives the number of current errors plus 1. If there are no current errors, the value of subindex 00 hex is 01 hex.
- Subindex 01 hex is the update count. The update count works as a counter that is updated when an error occurs. You can check for changes in the update count to detect when a new error occurs.
- The format of subindexes 02 hex to 21 hex is given below.

Field name	Size (bytes)	Description
Record Number	4	Instance of an error occurrence
Unit Number	1	The unit number of the EtherCAT Coupler Unit where the error occurred.
Event Level	1	Event Level 01 hex: Major fault level 02 hex: Partial fault level 03 hex: Minor fault level 04 hex: Observation 05 hex: Information
Time of Occurrence	4	The time the error occurred.*1
Product Code	4	The product code of the EtherCAT Coupler Unit where the error occurred. 00610201 hex: NX-ECC201 00610202 hex: NX-ECC202 00610203 hex: NX-ECC203
Event Code	4	The event code.*2
System Information	32	System information.

\*1. You can set the time by writing the time data to index 10F9 hex. Set the time data in seconds as the relative value from 1970/1/1, 0:00:00. If you do not set the time, the value of the time of occurrence will be 0 (1970/1/1, 0:00:00).

\*2. Refer to 13-3-2 *Event Codes for Errors and Troubleshooting Procedures* on page 13-14 for details.



### Precautions for Correct Use

- The value of subindex 01 hex has no specific meaning. You can use changes in the value of subindex 01 hex to determine when a new error has occurred.
- If there are more than 32 current errors, the value of subindex 00 hex remains at 21 hex (33 decimal) and is not updated. Therefore, use subindex 01 hex to determine if a new error has occurred.
- If there are less than 32 current errors, information on the current errors is stored in order starting from subindex 02 hex. However, when there are more than 32 current errors, the subindexes where the information on the new errors is stored is undefined. Therefore, when there are more than 32 current errors, read the values of subindex 02 hex to subindex 21 hex while monitoring the value of subindex 01 hex. If the value of subindex 01 hex changes while you are reading the information on current errors, read all of the values from subindex 02 hex to 21 hex.

Index (hex)	Sub-index (hex)	Object name	Default	Data range	Unit	Data attribute	Size	Access	PDO mapping	Complete access
380A	---	Coupler Unit Event Log	---	---	---	---	---	---	---	Not possible.
	00	Number of entries	01 hex	01 to 81 hex	---	---	1 byte (U8)	RO	Not possible.	---
	01	Newest record No.	---	---	---	---	4 bytes (U32)	RO	Not possible.	---
	02	Event log 1	---	---	---	---	50 bytes (ARRAY [0..49] OF BYTE)	RO	Not possible.	---
	...	...	...	...	...	...	...	...	...	...
	81	Event log 128	---	---	---	---	50 bytes (ARRAY [0..49] OF BYTE)	RO	Not possible.	---

- This object gives the event log from the EtherCAT Coupler Unit.
- Subindex 00 hex gives the number of event log records plus 1. If there are no event log records, the value of subindex 00 hex is 01 hex.
- Subindex 01 hex is the newest record number. The newest record number works as a counter that is updated when an event occurs. You can check for changes in the newest record number to detect when a new event occurs.
- The format of subindexes 02 hex to 81 hex is given below.

Field name	Size (bytes)	Description
Record Number	4	Instance of an event occurrence
Unit Number	1	The unit number of the EtherCAT Coupler Unit where the event occurred.
Event Level	1	Event Level 01 hex: Major fault level 02 hex: Partial fault level 03 hex: Minor fault level 04 hex: Observation 05 hex: Information
Time of Occurrence	4	The time the event occurred.*1
Product Code	4	The product code of the EtherCAT Coupler Unit where the event occurred. 00610201 hex: NX-ECC201 00610202 hex: NX-ECC202 00610203 hex: NX-ECC203
Event Code	4	The event code.*2
System Information	32	System information.

\*1. You can set the time by writing the time data to index 10F9 hex. Set the time data in seconds as the relative value from 1970/1/1, 0:00:00. If you do not set the time, the value of the time of occurrence will be 0 (1970/1/1, 0:00:00).

\*2. Refer to 13-3-2 Event Codes for Errors and Troubleshooting Procedures on page 13-14 for details.



### Precautions for Correct Use

- The value of subindex 01 hex has no specific meaning. You can use changes in the value of subindex 01 hex to determine when a new event has occurred.
- If there are more than 128 events, the value of subindex 00 hex remains at 81 hex (129 decimal) and is not updated. Therefore, use subindex 01 hex to determine if a new event has occurred.
- If there are less than 128 events, the event log contents are stored in order starting from subindex 02 hex. However, when there are more than 128 events in the event log, the subindexes where the information on the new events is stored is undefined. Therefore, when there are more than 128 events in the event log, read the values of subindex 02 hex to subindex 81 hex while monitoring the value of subindex 01 hex. If the value of subindex 01 hex changes while you are reading the information on events, read all of the values from subindex 02 hex to 81 hex.

Index (hex)	Subindex (hex)	Object name	Default	Data range	Unit	Data attribute	Size	Access	PDO mapping	Complete access
380B <sup>*1</sup>	---	Switch Parameter Write Mode	---	---	---	---	---	---	---	Not possible.
	00	Number of entries	3F hex	3F hex	---	---	1 byte (U8)	RO	Not possible.	---
	01	Switch Parameter Write Mode NX Unit 1	00000000 hex	00000000 to 52575250 hex	---	---	4 bytes (U32)	RW	Not possible.	---
	---	---	---	---	---	---	---	---	---	---
	3F	Switch Parameter Write Mode NX Unit 63	00000000 hex	00000000 to 52575250 hex	---	---	4 bytes (U32)	RW	Not possible.	---

\*1. This object can be used with NX-ECC203 version 1.5 or later.

- This object indicates the functions to change NX Units to Parameter Write Mode. You can change the parameters that are held for power interruptions only in an NX Unit that has been changed to Parameter Write Mode.
- Specify the NX Units to change to Parameter Write Mode with subindexes 01 hex to 3F hex. The number in the object name indicates the NX Unit number.
- The I/O data in the specified NX Units will be undefined during the mode change and the bits in NX Unit I/O Data Active Status will be 0 (FALSE). After you restart an NX Unit, do not use I/O data in controls until the relevant bits in NX Unit I/O Data Active Status change to 1 (TRUE).
- To prevent inadvertent changes in the mode, the NX Units will be changed to Parameter Write Mode only when a specific value is written to subindexes 01 hex to 3F hex. The specific value means "prwr".

MSB		LSB	
<b>r</b>	<b>w</b>	<b>r</b>	<b>p</b>
52 hex	57 hex	52 hex	50 hex

If you write a value other than the specific value, the abort code is returned.

- During a read, the object gives 00000001 hex (command enabled).
- You cannot use this object to change Safety CPU Units and Safety I/O Units to Parameter Write Mode. If you specify a Safety CPU Unit or Safety I/O Unit, the abort code is returned.

Index (hex)	Subindex (hex)	Object name	Default	Data range	Unit	Data attribute	Size	Access	PDO mapping	Complete access
380C*1	---	Coupler Unit Total Power - On Time	---	---	---	---	---	---	---	Not possible.
	00	Number of entries	40 hex	40 hex	---	---	1 byte (U8)	RO	Not possible.	---
	01	Coupler Unit Total Power - On Time	00000000 0000000 hex	000000000000 000 to FFFFFFFFFFFF FFFF hex	Minutes	---	8 bytes (U64)	RO	Not possible.	---

\*1. This object can be used with NX-ECC203 version 1.5 or later.

- This object gives the total power-ON time of the Communications Coupler Unit. The unit is minutes.
- If there are illegal values in EEPROM (i.e., if a Non-volatile Memory Hardware Error occurs) that prevents reading the total power-ON time, a value of FFFFFFFFFFFFFFFF hex will be returned.

Index (hex)	Subindex (hex)	Object name	Default	Data range	Unit	Data attribute	Size	Access	PDO mapping	Complete access
380D*1	---	NX Unit Total Power - On Time	---	---	---	---	---	---	---	Not possible.
	00	Number of entries	40 hex	40 hex	---	---	1 byte (U8)	RO	Not possible.	---
	01	NX Unit 1 Total Power - On Time	00000000 0000000 hex	000000000000 000 to FFFFFFFFFFFF FFFF hex	Minutes	---	8 bytes (U64)	RO	Not possible.	---
	---	---	---	---	---	---	---	---	---	---
	3F	NX Unit 63 Total Power-On Time	00000000 0000000 hex	000000000000 000 to FFFFFFFFFFFF FFFF hex	Minutes	---	8 bytes (U64)	RO	Not possible.	---

\*1. This object can be used with NX-ECC203 version 1.5 or later.

- This object gives the total power-ON times of NX Units. The unit is minutes.
- Use subindexes 01 hex to 3F hex to specify the NX Units. The number in the object name indicates the NX Unit number.
- If there are illegal values in EEPROM (i.e., if a Non-volatile Memory Hardware Error occurs) that prevents reading the total power-ON time, a value of FFFFFFFFFFFFFFFF hex will be returned.

Index (hex)	Subindex (hex)	Object name	Default	Data range	Unit	Data attribute	Size	Access	PDO mapping	Complete access
380E <sup>*1</sup>	---	NX Unit Restart	---	---	---	---	---	---	---	Not possible.
	00	Number of entries	40 hex	40 hex	---	---	1 byte (U8)	RO	Not possible.	---
	01	NX Unit 1 Restart	0000 hex	0000 hex	---	A	2 bytes (U16)	RW	Not possible.	---
	---	---	---	---	---	---	---	---	---	---
	3F	NX Unit 63 Restart	0000 hex	0000 hex	---	A	2 bytes (U16)	RW	Not possible.	---

\*1. This object can be used with NX-ECC203 version 1.5 or later.

- This object restarts NX Units.
- Use subindexes 01 hex to 3F hex to specify the NX Units. The number in the object name indicates the NX Unit number.
- The specified NX Units are restarted when *0000 hex* is written to subindexes 01 hex to 3F hex. If you write a value other than *0000 hex*, the abort code is returned.
- The I/O data for restarted NX Units is undefined.
- Do not use the I/O data in controls while the relevant bits in NX Unit I/O Data Active Status (index 3006 hex) are FALSE. After you restart an NX Unit, use the I/O data in controls only after you confirm that the relevant bits in NX Unit I/O Data Active Status (index 3006 hex) are TRUE.

Index (hex)	Subindex (hex)	Object name	Default	Data range	Unit	Data attribute	Size	Access	PDO mapping	Complete access
380F <sup>*1</sup>	---	Store Parameters Command	---	---	---	---	---	---	---	Not possible.
	00	Number of entries	03 hex	03 hex	---	---	1 byte (U8)	RO	Not possible.	---
	01	Store Parameters Command	01 hex, 00 hex, 00 hex, 00 hex	Read Byte 0: 01 hex Byte 1: 00 hex Byte 2: 00 hex Byte 3: 00 hex Write Byte 0: 73 hex Byte 1: 61 hex Byte 2: 30 to 33 hex or 76 hex Byte 3: 30 to 39 hex or 61 to 66 hex	---	A	ARRAY [0..3] OF BYTE	RW	Not possible.	---
	02	Store Parameters Status	00 hex	00 to FF hex	---	---	1 byte (U8)	RO	Not possible.	---
	03	Store Parameters Response	00 hex, 00 hex	Byte 0: 00 to FF hex Byte 1: 00 hex	---	---	ARRAY [0..1] OF BYTE	RO	Not possible.	---

\*1. This object can be used with NX-ECC203 version 1.5 or later.

- This object is used to store parameters.
- Use subindex 01 hex to specify the Store Parameters Command. Specify the value of the Store Parameters Command as given below according to the Unit for which to save the parameters.

Unit	Byte 0 (hex)	Byte 1 (hex)	Byte 2 (hex)	Byte 3 (hex)
Entire Slave Terminal	73 <sup>*1</sup>	61 <sup>*2</sup>	76 <sup>*3</sup>	65 <sup>*4</sup>
NX Unit			ASCII code for upper digit of unit number in 2-digit hexadecimal <sup>*5</sup>	ASCII code for lower digit of unit number in 2-digit hexadecimal <sup>*5</sup>

\*1. This indicates the ASCII code for "s".

\*2. This indicates the ASCII code for "a".

\*3. This indicates the ASCII code for "v".

\*4. This indicates the ASCII code for "e".

\*5. For example, if the unit number is 1, the value of byte 2 is 30 hex (i.e., the ASCII code for "0") and the value of byte 3 is 31 hex (i.e., the ASCII code for "1").

If the unit number is 63, the value of byte 2 is 33 hex (i.e., the ASCII code for "3") and the value of byte 3 is 66 hex (i.e., the ASCII code for "f").

- The abort code is returned in the following cases.
  - a) If you write any value other than the above values to subindex 01 hex
  - b) If you execute the Store Parameters Command again while saving the parameters is still in progress
  - c) If an NX Unit with the specified unit number is not in the Slave Terminal
- If you read subindex 01 hex, 00000001 hex (command enabled) is returned.

- The status of saving the parameters is stored in subindex 02 hex. The meanings of the values of the Store Parameters Status are given in the following table.

Store Parameters Status (hex)	Meaning
00	Store Parameters Command executed successfully, no response.
01	Reserved.
02	Store Parameters Command execution failed, no response.
03 to FE	Reserved.
FF	Store Parameters Command execution in progress.

- When the Store Parameters Command is acknowledged, an SDO response is immediately returned to the EtherCAT master. However, the parameters are not yet saved at that point. The results of the execution of the Store Parameters Command are stored in the Store Parameters Response in subindex 03 hex. The meanings of the values of the Store Parameters Response are the same as for the Store Parameters Status.
- If you execute index 1010 hex during execution of index 380F hex, the abort code is returned.
- The status of the NX Unit will not change when this object is executed.
- To save the parameters for the entire Slave Terminal, the EtherCAT Coupler Unit must be in Pre-Operational (Pre-Op) state. If it is not in Pre-Operational (Pre-Op) state, the abort code is returned.
- A message to save the parameters for an NX Unit will be acknowledged only if the NX Unit is in Parameter Write Mode. If it is not in Parameter Write Mode, the abort code is returned. If that occurs, use index 380B hex to change the NX Unit to Parameter Write Mode.
- You cannot use this object to save parameters for Safety CPU Units and Safety I/O Units. If you specify a Safety CPU Unit or Safety I/O Unit, the abort code is returned.
- If a Unit Configuration Verification Error occurs, the abort code is returned.

Index (hex)	Subindex (hex)	Object name	Default	Data range	Unit	Data attribute	Size	Access	PDO mapping	Complete access
3810*1	---	Restore Default Parameters Command	---	---	---	---	---	---	---	Not possible.
	00	Number of entries	03 hex	03 hex	---	---	1 byte (U8)	RO	Not possible.	---
	01	Restore Default Parameters Command	01 hex, 00 hex, 00 hex, 00 hex	Read Byte 0: 01 hex Byte 1: 00 hex Byte 2: 00 hex Byte 3: 00 hex Write Byte 0: 6C hex Byte 1: 6F hex Byte 2: 30 to 33 hex or 61 hex Byte 3: 30 to 39 hex or 61 to 66 hex	---	A	ARRAY[0..3] OF BYTE	RW	Not possible.	---
	02	Restore Default Parameters Status	00 hex	00 to FF hex	---	---	1 byte (U8)	RO	Not possible.	---
	03	Restore Default Parameters Response	00 hex, 00 hex	Byte 0: 00 to FF hex Byte 1: 00 hex	---	---	ARRAY[0..1] OF BYTE	RO	Not possible.	---

\*1. This object can be used with NX-ECC203 version 1.5 or later.

- This object initializes parameters.
- Use subindex 01 hex to specify the Restore Default Parameters Command. Specify the value of the Restore Default Parameters Command as given below according to the Unit for which to initialize the parameters.

Unit	Byte 0 (hex)	Byte 1 (hex)	Byte 2 (hex)	Byte 3 (hex)
Entire Slave Terminal	6C*1	6F*2	61*3	64*4
NX Unit			ASCII code for upper digit of unit number in 2-digit hexadecimal*5	ASCII code for lower digit of unit number in 2-digit hexadecimal*5

\*1. This indicates the ASCII code for "l".

\*2. This indicates the ASCII code for "o".

\*3. This indicates the ASCII code for "a".

\*4. This indicates the ASCII code for "d".

\*5. For example, if the unit number is 1, the value of byte 2 is 30 hex (i.e., the ASCII code for "0") and the value of byte 3 is 31 hex (i.e., the ASCII code for "1").

If the unit number is 63, the value of byte 2 is 33 hex (i.e., the ASCII code for "3") and the value of byte 3 is 66 hex (i.e., the ASCII code for "f").

- The abort code is returned in the following cases.
  - a) If you write any value other than the above values to subindex 01 hex
  - b) If you execute the Restore Default Parameters Command again while initializing the parameters is still in progress
  - c) If an NX Unit with the specified unit number is not in the Slave Terminal
- If you read subindex 01 hex, 00000001 hex (command enabled) is returned.

- The status of initializing the parameters is stored in subindex 02 hex. The meanings of the values of the Restore Default Parameters Status are given in the following table.

Restore Default Parameters Status (hex)	Meaning
00	Restore Default Parameters Command executed successfully, no response.
01	Reserved.
02	Restore Default Parameters Command execution failed, no response.
03 to FE	Reserved.
FF	Restore Default Parameters Command execution in progress.

- When the Restore Default Parameters Command is acknowledged, an SDO response is immediately returned to the EtherCAT master. However, the parameters are not yet initialized at that point. The results of the execution of the Restore Default Parameters Command are stored in the Restore Default Parameters Response in subindex 03 hex. The meanings of the values of the Restore Default Parameters Response are the same as for the Restore Default Parameters Status.
- If you execute index 1011 hex during execution of index 3810 hex, the abort code is returned.
- The status of the NX Unit will not change when this object is executed.
- To initialize the parameters for the entire Slave Terminal, the EtherCAT Coupler Unit must be in Pre-Operational (Pre-Op) state. If it is not in Pre-Operational (Pre-Op) state, the abort code is returned.
- A message to initialize the parameters for an NX Unit will be acknowledged only if the NX Unit is in Parameter Write Mode. If it is not in Parameter Write Mode, the abort code is returned. If that occurs, use index 380B hex to change the NX Unit to Parameter Write Mode.
- You cannot use this object to initialize parameters for Safety CPU Units and Safety I/O Units. If you specify a Safety CPU Unit or Safety I/O Unit, the abort code is returned.
- If a Unit Configuration Verification Error occurs, the abort code is returned.

Index (hex)	Sub-index (hex)	Object name	Default	Data range	Unit	Data attribute	Size	Access	PDO mapping	Complete access
4010 + ((NX Unit No. - 01) × 20)	---	NX Unit Current Errors	---	---	---	---	---	---	---	Not possible.
	00	Number of entries	01 hex	01 to 21 hex	---	---	1 byte (U8)	RO	Not possible.	---
	01	Update Count	---	---	---	---	2 bytes (U16)	RO	Not possible.	---
	02	Current Error 1	---	---	---	---	50 bytes (AR-RAY[0..49] OF BYTE)	RO	Not possible.	---
	---	---	---	---	---	---	---	---	---	---
	21	Current Error 32	---	---	---	---	50 bytes (AR-RAY[0..49] OF BYTE)	RO	Not possible.	---

- This object gives the current errors in the NX Unit.
- Subindex 00 hex gives the number of current errors plus 1. If there are no current errors, the value of subindex 00 hex is 01 hex.

- Subindex 01 hex is the update count. The update count works as a counter that is updated when an error occurs. You can check for changes in the update count to detect when a new error occurs.
- The format of subindexes 02 hex to 21 hex is given below.

Field name	Size (bytes)	Description
Record Number	4	Instance of an error occurrence
Unit Number	1	The unit number of the NX Unit where the event occurred.
Event Level	1	Event Level 01 hex: Major fault level 02 hex: Partial fault level 03 hex: Minor fault level 04 hex: Observation 05 hex: Information
Time of Occurrence	4	The time the error occurred.*1
Product Code	4	The unique product code of the NX Unit where the error occurred.
Event Code	4	The event code.*2
System Information	32	System information.

\*1. You can set the time by writing the time data to index 10F9 hex. Set the time data in seconds as the relative value from 1970/1/1, 0:00:00. If you do not set the time, the value of the time of occurrence will be 0 (1970/1/1, 0:00:00).

\*2. Refer to the manuals for the NX Units for details.



### Precautions for Correct Use

- The value of subindex 01 hex has no specific meaning. You can use changes in the value of subindex 01 hex to determine when a new error has occurred.
- If there are more than 32 current errors, the value of subindex 00 hex remains at 21 hex (33 decimal) and is not updated. Therefore, use subindex 01 hex to determine if a new error has occurred.
- If there are less than 32 current errors, information on the current errors is stored in order starting from subindex 02 hex. However, when there are more than 32 current errors, the subindexes where the information on the new errors is stored is undefined. Therefore, when there are more than 32 current errors, read the values of subindex 02 hex to subindex 21 hex while monitoring the value of subindex 01 hex. If the value of subindex 01 hex (Newest record No.) changes while you are reading the information on current errors, read all of the values from subindex 02 hex (Event log 1) to 21 hex (Event log 128).

Index (hex)	Subindex (hex)	Object name	Default	Data range	Unit	Data attribute	Size	Access	PDO mapping	Complete access
4011 + (NX Unit No. - 01) × 20)	---	NX Unit Event Log	---	---	---	---	---	---	---	Not possible.
	00	Number of entries	01 hex	01 to 81 hex	---	---	1 byte (U8)	RO	Not possible.	---
	01	Newest record No.	---	---	---	---	4 bytes (U32)	RO	Not possible.	---
	02	Event log 1	---	---	---	---	50 bytes (AR-RAY[0..49] OF BYTE)	RO	Not possible.	---
	---	---	---	---	---	---	---	---	---	---
	81	Event log 128	---	---	---	---	50 bytes (AR-RAY[0..49] OF BYTE)	RO	Not possible.	---

- This object gives the event log from the NX Unit.
- Subindex 00 hex gives the number of event log records plus 1. If there are no event log records, the value of subindex 00 hex is 01 hex.
- Subindex 01 hex is the newest record number. The newest record number works as a counter that is updated when an event occurs. You can check for changes in the newest record number to detect when a new event occurs.
- The format of subindexes 02 hex to 81 hex is given below.

Field name	Size (bytes)	Description
Record Number	4	Instance of an event occurrence
Unit Number	1	The unit number of the NX Unit where the event occurred.
Event Level	1	Event Level 01 hex: Major fault level 02 hex: Partial fault level 03 hex: Minor fault level 04 hex: Observation 05 hex: Information
Time of Occurrence	4	The time the event occurred.*1
Product Code	4	The unique product code of the NX Unit where the event occurred.
Event Code	4	The event code.*2
System Information	32	System information.

\*1. You can set the time by writing the time data to index 10F9 hex. Set the time data in seconds as the relative value from 1970/1/1, 0:00:00. If you do not set the time, the value of the time of occurrence will be 0 (1970/1/1, 0:00:00).

\*2. Refer to the manuals for the NX Units for details.



**Precautions for Correct Use**

- The value of subindex 01 hex has no specific meaning. You can use changes in the value of subindex 01 hex to determine when a new event has occurred.
- If there are more than 128 events, the value of subindex 00 hex remains at 81 hex (129 decimal) and is not updated. Therefore, use subindex 01 hex to determine if a new event has occurred.
- If there are less than 128 events, the event log contents are stored in order starting from subindex 02 hex. However, when there are more than 128 events in the event log, the subindexes where the information on the new events is stored is undefined. Therefore, when there are more than 128 events in the event log, read the values of subindex 02 hex to subindex 81 hex while monitoring the value of subindex 01 hex. If the value of subindex 01 hex changes while you are reading the information on events, read all of the values from subindex 02 hex to 81 hex.

Index (hex)	Subindex (hex)	Object name	Default	Data range	Unit	Data attribute	Size	Access	PDO mapping	Complete access
4012 + ((NX Unit No. - 01) × 20)	---	NX Unit Event Log Clear	00000000 hex	00000000 to FFFFFFFF hex	---	A	4 bytes (U32)	RW	---	Not possible.

- This object clears the event log from an NX Unit.
- To prevent inadvertent clearing of the event log, the event log is cleared only when a specific value is written.

The specific value means "elcl".

MSB			LSB
l	c	l	e
6c hex	63 hex	6c hex	65 hex

If you write a value other than the specific value, the abort code is returned.

- During a read, the object gives 00000001 hex (command enabled).

Index (hex)	Subindex (hex)	Object name	Default	Data range	Unit	Data attribute	Size	Access	PDO mapping	Complete access
5000 + ((NX Unit No. - 01) × 20) <sup>*1</sup>	*2	*2	*2	*2	*2	*2	*2	*2	*2	*2

\*1. These subindexes can be used with NX-ECC203 version 1.5 or later.

\*2. The contents depends on the specifications of the NX Unit.

- This object is used to read and edit the Unit operation settings of an NX Unit.
- Index numbers from index 5000 + (NX Unit number - 01) × 20 hex to 501F + (NX Unit number - 01) × 20 hex correspond to NX objects 5000 hex to 501F hex in the NX Unit. The following table shows a corresponding example of index numbers and NX object index numbers for NX Unit number 1 and 4.

NX Unit number	Index (hex)	NX object index (hex)
1	5000	5000
	---	---
	501F	501F
4	5060	5000
	---	---
	507F	501F

- Refer to the manuals for the NX Units for specifications of the NX objects for each NX Unit.
- You cannot use this object for the NX-series Pulse Output Unit NX-PG0□□□.

## A-7-10 Device Profile Area

The device profile area for the EtherCAT Slave Terminal is listed below.

Index (hex)	Description
6000 to 6FFF	Input Data Object Area
7000 to 7FFF	Output Data Object Area
8000 to 801F	Configuration Area
9000 to 901F	Information Area

### Input Data Object Area

The following figure and table show how index numbers for input data objects are assigned to the NX Units in an EtherCAT Slave Terminal.

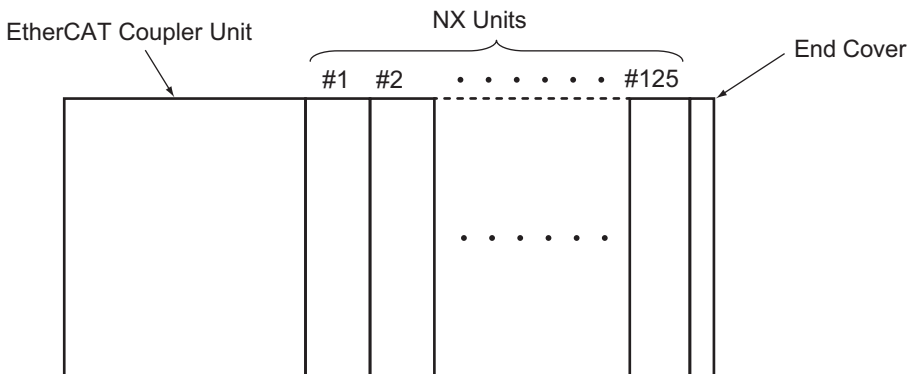

Object type	NX Units*1			
	#1	#2	---	#125
Input Data Objects (application objects for TxPDOs)	6000 to 601F hex	6020 to 603F hex	---	6F80 to 6F9F hex

\*1. #1 to #125 are the NX Unit numbers for the NX Units.

This object does not allow complete access.

The reading and writing specifications for this object are listed below.

- If the Object Is Mapped to a PDO:  
Reading and writing are not allowed.
- If the Object Is Not Mapped to a PDO:

Reading and writing depend on the communications control status. The specifications are given in the following table.

Status	Specification
Pre-Operational	Reading and writing are not allowed.
Safe-Operational	Reading is allowed and writing is not allowed.
Operational	Reading is allowed and writing is not allowed.

## Output Data Object Area

The following figure and table show how index numbers for output data objects are assigned to the NX Units in an EtherCAT Slave Terminal.

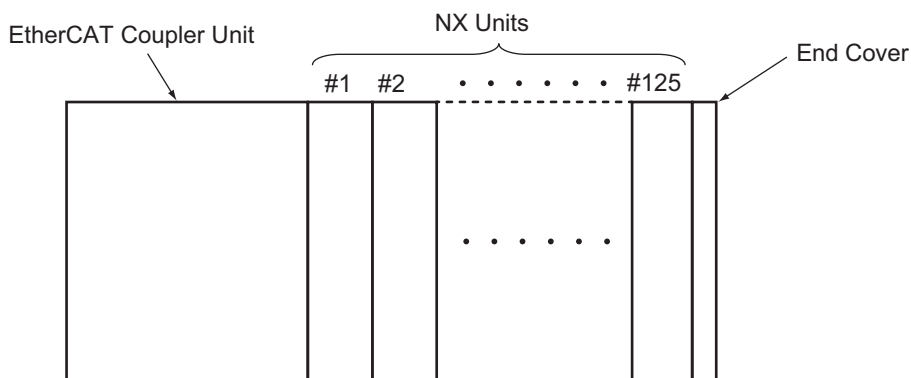

Object type	NX Units <sup>*1</sup>			
	#1	#2	---	#125
Output Data Objects (application objects for RxPDOs)	7000 to 701F hex	7020 to 703F hex	---	7F80 to 7F9F hex

\*1. #1 to #125 are the NX Unit numbers for the NX Units.

This object does not allow complete access.

The reading and writing specifications for this object are listed below.

- If the Object Is Mapped to a PDO:

Reading and writing are not allowed.

- If the Object Is Not Mapped to a PDO:

Reading and writing depend on the communications control status. The specifications are given in the following table.

Status	Specification
Pre-Operational	Reading and writing are not allowed.
Safe-Operational	Reading is allowed and writing is not allowed.
Operational	Reading and writing are allowed.

## Configuration Object Area

The following figure and table show how index numbers for configuration objects are assigned to the EtherCAT Slave Terminal.

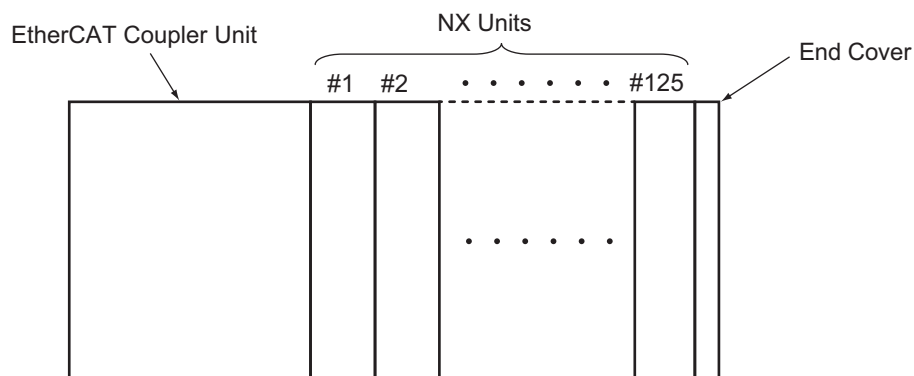

Object type	NX Units*1			
	#1	#2	---	#125
Configuration Objects	8000 to 801F hex	8020 to 803F hex	---	8F80 to 8F9F hex

\*1. #1 to #125 are the NX Unit numbers for the NX Units.

Index (hex)	Sub-index (hex)	Object name	Default	Data range	Unit	Data attribute	Size	Access	PDO mapping	Complete access
8000 + ((NX Unit No. - 01) × 20)	---	Configuration Area 1	---	---	---	---	---	---	---	Possible.
	00	Number of entries	0A hex	0A hex	---	---	1 byte (U8)	RO	Not possible.	---
	01	Unit No	NX Unit number	0000 to 007D hex	---	---	2 bytes (U16)	RO	Not possible.	---
	04	Device Type	Depends on Unit.	00000000 to FFFFFFFF hex	---	---	4 bytes (U32)	RO	Not possible.	---
	05	Vendor Code	Depends on Unit.	00000000 to FFFFFFFF hex	---	---	4 bytes (U32)	RO	Not possible.	---
	06	Product Code	Depends on Unit.	00000000 to FFFFFFFF hex	---	---	4 bytes (U32)	RO	Not possible.	---
	07	Unit Version	Depends on Unit.	00000000 to FFFFFFFF hex	---	---	4 bytes (U32)	RO	Not possible.	---
	08	Serial Number	Depends on Unit.	00000000 to FFFFFFFF hex	---	---	4 bytes (U32)	RO	Not possible.	---
	09	Module PDO group	Depends on Unit.	0000 to FFFF hex	---	---	2 bytes (U16)	RO	Not possible.	---
	0 A	Module Ident	Depends on Unit.	00000000 to FFFFFFFF hex	---	---	4 bytes (U32)	RO	Not possible.	---

- This object gives information that describes the Unit configuration that was downloaded for the NX Units.

- Subindex 01 hex gives the NX Unit number of the NX Unit.
- Subindex 04 hex gives the unique device type for the NX Unit.
- Subindex 05 hex gives the unique vendor code for the NX Unit.
- Subindex 06 hex gives the unique product code for the NX Unit.
- Subindex 07 hex gives the unique Unit revision of the NX Unit.
- Subindex 08 hex gives the unique serial number for the NX Unit.
- Subindex 09 hex gives the PDO group number where the NX Unit is assigned.
  - 0004 hex: Safety PDO group
  - 0003 hex: Bit PDO group
  - 0002 hex: Word PDO group
  - 0001 hex: Coupler PDO group
- Subindex 0A hex gives the module identification number of the NX Unit.

## Information Object Area

The following figure and table show how index numbers for information objects are assigned to the EtherCAT Slave Terminal.

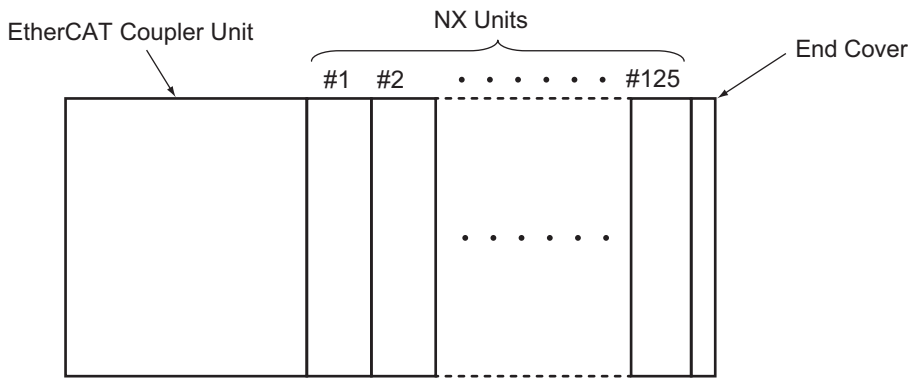

Object type	NX Units <sup>*1</sup>			
	#1	#2	---	#125
Information Object	9000 to 901F hex	9020 to 903F hex	---	9F80 to 9F9F hex

\*1. #1 to #125 are the NX Unit numbers for the NX Units.

Index (hex)	Subindex (hex)	Object name	Default	Data range	Unit	Data attribute	Size	Access	PDO mapping	Complete access
9000 + ((NX Unit No. - 01) × 20)	---	Information Area 1	---	---	---	---	---	---	---	Possible.
	00	Number of entries	0A hex	0A hex	---	---	1 byte (U8)	RO	Not possible.	---
	01	Unit No	NX Unit number	0000 to 007D hex	---	---	2 bytes (U16)	RO	Not possible.	---
	04	Device Type	Depends on Unit.	00000000 to FFFFFFFF hex	---	---	4 bytes (U32)	RO	Not possible.	---
	05	Vendor Code	Depends on Unit.	00000000 to FFFFFFFF hex	---	---	4 bytes (U32)	RO	Not possible.	---
	06	Product Code	Depends on Unit.	00000000 to FFFFFFFF hex	---	---	4 bytes (U32)	RO	Not possible.	---
	07	Unit Version	Depends on Unit.	00000000 to FFFFFFFF hex	---	---	4 bytes (U32)	RO	Not possible.	---
	08	Serial Number	Depends on Unit.	00000000 to FFFFFFFF hex	---	---	4 bytes (U32)	RO	Not possible.	---
	09	Module PDO group	Depends on Unit.	0000 to FFFF hex	---	---	2 bytes (U16)	RO	Not possible.	---
	0A	Module Ident	Depends on Unit.	00000000 to FFFFFFFF hex	---	---	4 bytes (U32)	RO	Not possible.	---

- This object gives information that describes the actual Unit configuration of the NX Units.
- Subindex 01 hex gives the NX Unit number of the NX Unit.
- Subindex 04 hex gives the unique device type for the NX Unit.
- Subindex 05 hex gives the unique vendor code for the NX Unit.
- Subindex 06 hex gives the unique product code for the NX Unit.
- Subindex 07 hex gives the unique Unit revision of the NX Unit.
- Subindex 08 hex gives the unique serial number for the NX Unit.
- Subindex 09 hex gives the PDO group number where the NX Unit is assigned.
  - 0004 hex: Safety PDO group
  - 0003 hex: Bit PDO group
  - 0002 hex: Word PDO group
  - 0001 hex: Coupler PDO group
- Subindex 0A hex gives the module identification number of the NX Unit.

## A-7-11 Modular Device-specific Area

Index (hex)	Subindex (hex)	Object name	Default	Data range	Unit	Data attribute	Size	Access	PDO mapping	Complete access
F000	---	Modular Device Profile	---	---	---	---	---	---	---	Possible.
	00	Number of objects	05 hex	05 hex	---	---	1 byte (U8)	RO	Not possible.	---
	01	Index distance	0020 hex	0020 hex	---	---	2 bytes (U16)	RO	Not possible.	---
	02	Maximum number of modules	007D hex	007D hex	---	---	2 bytes (U16)	RO	Not possible.	---
	03	General configuration	000003F9 hex	000003F9 hex	---	---	4 bytes (U32)	RO	Not possible.	---
	04	General Information	000003F9 hex	000003F9 hex	---	---	4 bytes (U32)	RO	Not possible.	---
	05	Module PDO Group of device	0004 hex	0004 hex	---	---	2 bytes (U16)	RO	Not possible.	---

- This object gives the profile information.
- Subindex 01 hex gives the interval between indexes.
- Subindex 02 hex gives the number of NX Units that you can connect.
- Subindex 03 hex gives the valid subindexes in the object dictionary from 8000 to 8F9F hex. Each bit position gives a supported subindex.
- Subindex 04 hex gives the valid subindexes in the object dictionary from 9000 to 9F9F hex. Each bit position gives a supported subindex.
- Subindex 05 hex gives the number of PDO groups in the module.

Index (hex)	Sub-index (hex)	Object name	Default	Data range	Unit	Data attribute	Size	Access	PDO mapping	Complete access
F00E	---	Module PDO Group Alignment PDO Number	---	---	---	---	---	---	---	Possible.
	00	Number of objects	04 hex	04 hex	---	---	1 byte (U8)	RO	Not possible.	---
	01	PDO Number of Module Group 0	01F4 hex	01F4 hex	---	---	2 bytes (U16)	RO	Not possible.	---
	02	PDO Number of Module Group 1	01F5 hex	01F5 hex	---	---	2 bytes (U16)	RO	Not possible.	---
	03	PDO Number of Module Group 2	01F6 hex	01F6 hex	---	---	2 bytes (U16)	RO	Not possible.	---
	04	PDO Number of Module Group 3	01F7 hex	01F7 hex	---	---	2 bytes (U16)	RO	Not possible.	---

- This object gives the alignment PDO number for the module PDO group.
- Subindex 01 hex gives the PDO numbers 17F4 and 1BF4 hex for module group 0.
- Subindex 02 hex gives the PDO numbers 17F5 and 1BF5 hex for module group 1.
- Subindex 03 hex gives the PDO numbers 17F6 and 1BF6 hex for module group 2.
- Subindex 04 hex gives the PDO numbers 17F7 and 1BF7 hex for module group 3.

Index (hex)	Sub-index (hex)	Object name	Default	Data range	Unit	Data attribute	Size	Access	PDO mapping	Complete access
F00F	---	Module PDO Group Alignment	---	---	---	---	---	---	---	Possible.
	00	Number of objects	04 hex	04 hex	---	---	1 byte (U8)	RO	Not possible.	---
	01	Alignment in bytes of Module Group 0	02 hex	02 hex	---	---	1 byte (U8)	RO	Not possible.	---
	02	Alignment in bytes of Module Group 1	02 hex	02 hex	---	---	1 byte (U8)	RO	Not possible.	---
	03	Alignment in bytes of Module Group 2	02 hex	02 hex	---	---	1 byte (U8)	RO	Not possible.	---
	04	Alignment in bytes of Module Group 3	02 hex	02 hex	---	---	1 byte (U8)	RO	Not possible.	---

- This object gives the alignment size for the module PDO group.
- Subindex 01 hex gives the alignment size for module group 0.
- Subindex 02 hex gives the alignment size for module group 1.
- Subindex 03 hex gives the alignment size for module group 2.
- Subindex 04 hex gives the alignment size for module group 3.

Index (hex)	Sub-index (hex)	Object name	Default	Data range	Unit	Data attribute	Size	Access	PDO mapping	Complete access
F030	---	Configured Module Ident List 1	---	---	---	---	---	---	---	Possible.
	00	Number of objects	7D hex	7D hex	---	---	1 byte (U8)	RO	Not possible.	---
	01	Module Ident of the module configured on position 1	Depends on Unit.	00000000 to FFFFFFFF hex	---	---	4 bytes (U32)	RO	Not possible.	---
	---	---	---	---	---	---	---	---	---	---
	7D	Module Ident of the module configured on position 125	Depends on Unit.	00000000 to FFFFFFFF hex	---	---	4 bytes (U32)	RO	Not possible.	---

- This object gives the module ID information in the settings information.
- Subindexes 01 to 7D hex give the module ID information for each NX Unit from NX Unit number 1 to 125.

Index (hex)	Sub-index (hex)	Object name	Default	Data range	Unit	Data attribute	Size	Access	PDO mapping	Complete access
F050	---	Detected Module Ident List 1	---	---	---	---	---	---	---	Possible.
	00	Number of objects	7D hex	7D hex	---	---	1 byte (U8)	RO	Not possible.	---
	01	Module Ident of the module detected on position 1	Depends on Unit.	00000000 to FFFFFFFF hex	---	---	4 bytes (U32)	RO	Not possible.	---
	---	---	---	---	---	---	---	---	---	---
	7D	Module Ident of the module detected on position 125	Depends on Unit.	00000000 to FFFFFFFF hex	---	---	4 bytes (U32)	RO	Not possible.	---

- This object gives the module ID information in the actual configuration information.
- Subindexes 01 to 7D hex give the module ID information for each NX Unit from NX Unit number 1 to 125.

# A-8 NX Objects

This section explains the NX objects that are implemented by the EtherCAT Coupler Unit.

## A-8-1 NX Objects

NX objects are exclusively for EtherCAT Slave Terminals.

Access those NX objects if you want to access data which is not allocated to I/O or data for unit operation settings on the EtherCAT Slave Terminal.

You can read or write these objects with special instructions that are supported by the NJ/NX-series CPU Units and NY-series Industrial PCs. The *Read NX Unit Object* (NX\_ReadObj) instruction reads NX objects, and the *Write NX Unit Object* (NX\_WriteObj) writes NX objects. Refer to the instructions reference manual for the connected CPU Unit or Industrial PC for information on the instructions.

Refer to the manuals for the individual NX Units for details on the NX objects that are implemented by each NX Unit.

## A-8-2 Format of Object Descriptions

This manual describes NX objects with the following format.

Index (hex)	Subindex (hex)	Object name	Default	Data range	Unit	Data type	Access	I/O allocation	Data attribute
<Index>	<Subindex>	<Object name>	<Default>	<Data range>	<Unit>	<Data type>	<Access>	<I/O allocation>	<Data attribute>

Items within the <> brackets are replaced with data. Each item has the following meaning.

Item	Description
Index	This is the index of the object that is expressed as a four-digit hexadecimal number.
Subindex	This is the subindex of the object that is expressed as a two-digit hexadecimal number.
Object name	This is the name of the object. For a subindex, this is the name of the subindex.
Default	This is the value that is set by default.
Data range	For a read-only (RO) object, this is the range of the data that you can read. For a read/write (RW) object, this is the setting range of the data.
Unit	The unit is the physical units.
Data type	This is the data type of the object.
Access	This data tells if the object is read-only or read/write. RO: Read only RW: Read/write
I/O allocation	This tells whether I/O allocation is allowed.
Data attribute	This is the timing when changes to writable objects are enabled. Y: Enabled by restarting N: Enabled at all times ---: Write-prohibited

### A-8-3 Unit Information Object

This object gives the product information.

Index (hex)	Subindex (hex)	Object name	Default	Data range	Unit	Data type	Access	I/O allocation	Data attribute
1000	---	NX Bus Identity	---	---	---	---	---	---	---
	00	Number of Entries	7	7	---	USINT	RO	Not possible.	---
	02	Model	---	---	---	ARRAY[0..11] OF BYTE	RO	Not possible.	---
	04	Product Code	---	---	---	UDINT	RO	Not possible.	---
	05	Vendor Code	00000001 hex	---	---	UDINT	RO	Not possible.	---
	06	Unit version	---	---	---	UDINT	RO	Not possible.	---
	07	Serial Number	---	00000000 to FFFFFFFF hex	---	UDINT	RO	Not possible.	---

- Subindex 02 hex returns the Unit model number in ASCII. If all 12 bytes are not required, the remaining bytes are filled with spaces (\$20).
- Subindex 04 hex returns 00610201 hex for the NX-ECC201 and 00610202 hex for the NX-ECC202. The NX-ECC203 returns 00610203 hex.
- Subindex 06 hex gives the Unit version of the product.  
 Bits 24 to 31: Integer part of the Unit version.  
 Bits 16 to 23: Fractional part of the Unit version.  
 Bits 0 to 15: Reserved
- Subindex 07 hex gives the serial number of the product.

Index (hex)	Subindex (hex)	Object name	Default	Data range	Unit	Data type	Access	I/O allocation	Data attribute
1001	---	Production Info	---	---	---	---	---	---	---
	00	Number of Entries	4	4	---	USINT	RO	Not possible.	---
	01	Lot Number	---	00000000 to FFFFFFFF hex	---	UDINT	RO	Not possible.	---
	02	Hardware Version	"V1.00" (padded with 15 spaces (character 20 hex))	---	---	ARRAY[0..19] OF BYTE	RO	Not possible.	---
	03	Software Version	---	---	---	ARRAY[0..19] OF BYTE	RO	Not possible.	---

- Subindex 01 hex gives the lot number of the product.

- Subindex 02 hex gives the hardware version as a text string.
- Subindex 03 hex gives the software version as a text string.

## A-8-4 Objects That Accept I/O Allocations

These objects accept I/O allocations.

Refer to *Allocatable I/O Data in an EtherCAT Coupler Unit* on page 9-16 and *Details of I/O Data in the EtherCAT Coupler Unit* on page 9-19 under *9-2-4 I/O Allocation Information* on page 9-15 for details on the data for objects that allow I/O allocations.

Index (hex)	Subindex (hex)	Object name	Default	Data range	Unit	Data type	Access	I/O allocation	Data attribute	
2001	---	Sysmac Error Status	---	---	---	---	---	---	---	
	00	Number of Entries	1	1	---	USINT	RO	Not possible.	---	
	01	Sysmac Error Status	02 hex	---	---	---	BYTE	RO	Possible.	---
		Observation	FALSE	TRUE or FALSE	---	---	BOOL	RO	Possible.	---
	Minor Fault	FALSE	TRUE or FALSE	---	---	BOOL	RO	Possible.	---	

- Subindex 01 hex gives the Sysmac error status for the EtherCAT Slave Terminal.

Index (hex)	Subindex (hex)	Object name	Default	Data range	Unit	Data type	Access	I/O allocation	Data attribute
2003	---	NX Unit Registration Status	---	---	---	---	---	---	---
	00	Number of Entries	4	4	---	USINT	RO	Not possible.	---
	01	NX Unit Registration Status 15	FALSE	TRUE or FALSE	---	ARRAY[0..15] OF BOOL	RO	Possible.	---
	02	NX Unit Registration Status 31	FALSE	TRUE or FALSE	---	ARRAY[0..31] OF BOOL	RO	Possible.	---
	03	NX Unit Registration Status 63	FALSE	TRUE or FALSE	---	ARRAY[0..63] OF BOOL	RO	Possible.	---
	04	NX Unit Registration Status 125	FALSE	TRUE or FALSE	---	ARRAY[0..125] OF BOOL	RO	Possible.	---

- Subindexes 01 to 04 hex tell whether the NX Unit is registered in the Unit configuration information.

Index (hex)	Subindex (hex)	Object name	Default	Data range	Unit	Data type	Access	I/O allocation	Data attribute
2004	---	NX Unit Message Enabled Status	---	---	---	---	---	---	---
	00	Number of Entries	4	4	---	USINT	RO	Not possible.	---
	01	NX Unit Message Enabled Status 15	FALSE	TRUE or FALSE	---	ARRAY[0..15] OF BOOL	RO	Possible.	---
	02	NX Unit Message Enabled Status 31	FALSE	TRUE or FALSE	---	ARRAY[0..31] OF BOOL	RO	Possible.	---
	03	NX Unit Message Enabled Status 63	FALSE	TRUE or FALSE	---	ARRAY[0..63] OF BOOL	RO	Possible.	---
	04	NX Unit Message Enabled Status 125	FALSE	TRUE or FALSE	---	ARRAY[0..125] OF BOOL	RO	Possible.	---

- Subindexes 01 to 04 tell whether the message communications are enabled in the NX Units.

Index (hex)	Subindex (hex)	Object name	Default	Data range	Unit	Data type	Access	I/O allocation	Data attribute
2005	---	NX Unit I/O Data Active Status	---	---	---	---	---	---	---
	00	Number of Entries	4	4	---	USINT	RO	Not possible.	---
	01	NX Unit I/O Data Active Status 15	FALSE	TRUE or FALSE	---	ARRAY[0..15] OF BOOL	RO	Possible.	---
	02	NX Unit I/O Data Active Status 31	FALSE	TRUE or FALSE	---	ARRAY[0..31] OF BOOL	RO	Possible.	---
	03	NX Unit I/O Data Active Status 63	FALSE	TRUE or FALSE	---	ARRAY[0..63] OF BOOL	RO	Possible.	---
	04	NX Unit I/O Data Active Status 125	FALSE	TRUE or FALSE	---	ARRAY[0..125] OF BOOL	RO	Possible.	---

- Subindexes 01 to 04 tell whether the NX Units can perform I/O data communications.

Index (hex)	Subindex (hex)	Object name	Default	Data range	Unit	Data type	Access	I/O allocation	Data attribute
2006	---	NX Unit Error Status	---	---	---	---	---	---	---
	00	Number of Entries	4	4	---	USINT	RO	Not possible.	---
	01	NX Unit Error Status 15	FALSE	TRUE or FALSE	---	ARRAY[0..15] OF BOOL	RO	Possible.	---
	02	NX Unit Error Status 31	FALSE	TRUE or FALSE	---	ARRAY[0..31] OF BOOL	RO	Possible.	---
	03	NX Unit Error Status 63	FALSE	TRUE or FALSE	---	ARRAY[0..63] OF BOOL	RO	Possible.	---
	04	NX Unit Error Status 125	FALSE	TRUE or FALSE	---	ARRAY[0..125] OF BOOL	RO	Possible.	---

- Subindexes 01 to 04 tell whether errors exist in the NX Units.

Index (hex)	Subindex (hex)	Object name	Default	Data range	Unit	Data type	Access	I/O allocation	Data attribute
200A	---	Time Stamps of Synchronous I/O Refresh	---	---	---	---	---	---	---
	00	Number of Entries	2	2	---	USINT	RO	Not possible.	---
	01	Time Stamp of Synchronous Input	0	0 to 18446744073709551615	ns	ULINT	RO	Possible.	---
	02	Time Stamp of Synchronous Output	0	0 to 18446744073709551615	ns	ULINT	RO	Possible.	---

- Subindex 01 hex gives the time stamp for when the NX Unit performed synchronous input refreshing.
- Subindex 02 hex gives the time stamp for when the NX Unit performed synchronous output refreshing.

## A-8-5 Other Objects

This section lists other objects.

Index (hex)	Subindex (hex)	Object name	Default	Data range	Unit	Data type	Access	I/O allocation	Data attribute
2002	---	Coupler Unit Sysmac Error Status	---	---	---	---	---	---	---
	00	Number of Entries	1	1	---	USINT	RO	Not possible.	---
	01	Coupler Unit Sysmac Error Status	0002 hex	---	---	WORD	RO	Not possible.	---
		Coupler Unit Observation	FALSE	TRUE or FALSE	---	BOOL	RO	Not possible.	---
		Coupler Unit Minor Fault	FALSE	TRUE or FALSE	---	BOOL	RO	Not possible.	---

- Subindex 01 hex gives the Sysmac error status for the EtherCAT Coupler Unit.
- The assignments of bits for subindex 01 hex are listed below. A bit is FALSE if no error exists or TRUE if an error exists. Bit 1 is always 1 (TRUE). Bit 1 does not indicate an error.  
 Bits 6 to 15: Reserved  
 Bit 5: Minor Fault  
 Bit 4: Observation  
 Bits 0 to 3: Reserved
- Each bit is updated at the following times.  
 The status changes to TRUE when an error occurs.  
 The status changes to FALSE when the error is reset. Even if the cause of the error has been removed, you must reset the error for the status to change to FALSE.

Index (hex)	Subindex (hex)	Object name	Default	Data range	Unit	Data type	Access	I/O allocation	Data attribute	
2007	---	NX Unit Sysmac Error Status	---	---	---	---	---	---	---	
	00	Number of Entries	125	125	---	USINT	RO	Not possible.	---	
	01	NX Unit 1 Sysmac Error Status	0000 hex	---	---	---	WORD	RO	Not possible.	---
		NX Unit 1 Observation	FALSE	TRUE or FALSE	---	---	BOOL	RO	Not possible.	---
		NX Unit 1 Minor Fault	FALSE	TRUE or FALSE	---	---	BOOL	RO	Not possible.	---
	02	NX Unit 2 Sysmac Error Status	0000 hex	---	---	---	WORD	RO	Not possible.	---
		NX Unit 2 Observation	FALSE	TRUE or FALSE	---	---	BOOL	RO	Not possible.	---
		NX Unit 2 Minor Fault	FALSE	TRUE or FALSE	---	---	BOOL	RO	Not possible.	---
	---	---	---	---	---	---	---	---	---	---
	7D	NX Unit 125 Sysmac Error Status	0000 hex	---	---	---	WORD	RO	Not possible.	---
		NX Unit 125 Observation	FALSE	TRUE or FALSE	---	---	BOOL	RO	Not possible.	---
		NX Unit 125 Minor Fault	FALSE	TRUE or FALSE	---	---	BOOL	RO	Not possible.	---

- Subindexes 01 to 7D hex give the Sysmac error status of each NX Unit from NX Unit number 1 to 125. The number in the object name gives the NX Unit number for the NX Unit for which the status is acquired.
- The assignments of bits for subindexes 01 to 7D hex are listed below. A bit is FALSE if no error exists or TRUE if an error exists.  
 Bits 6 to 15: Reserved  
 Bit 5: Minor Fault  
 Bit 4: Observation  
 Bits 0 to 3: Reserved
- Each bit is updated at the following times.  
 The status changes to TRUE when an error occurs.  
 The status changes to FALSE when the error is reset. Even if the cause of the error has been removed, you must reset the error for the status to change to FALSE.

Index (hex)	Subindex (hex)	Object name	Default	Data range	Unit	Data type	Access	I/O allocation	Data attribute
200B*1	---	New Messages Available	---	---	---	---	---	---	---
	00	Number of Entries	1	1	---	USINT	RO	Not possible.	---
	01	New Messages Available	0000 hex	0000 hex or 0001 hex	---	WORD	RO	Possible.	---
		New Messages Available Flag	FALSE	TRUE or FALSE	---	BOOL	RO	Possible.	---
		Padding	0	0	---	15 bits	RO	Possible.	---

\*1. This object can be used with NX-ECC203 version 1.5 or later.

- Subindex 01 hex indicates whether the error log is updated.
- Subindex 01 hex is updated at the following times.  
The status changes to TRUE when the error log is updated.  
The status changes to FALSE when the subindex number of the most recent error log record is written to index 10F3 hex (Diagnosis History), subindex 04 hex (New Messages Available) of the CoE objects depends on the EtherCAT master.
- Refer to *Diagnosis History* on page A-40 for details on index 10F3 hex (Diagnosis History) of the CoE objects.

Index (hex)	Subindex (hex)	Object name	Default	Data range	Unit	Data type	Access	I/O allocation	Data attribute
4000	---	NX Unit Configuration	---	---	---	---	---	---	---
	00	Number of Entries	4	4	---	USINT	RO	Not possible.	---
	04	NX Unit Serial Number Verification Setting	0	0 to 1	---	USINT	RW	Not possible.	Y

- Subindex 04 tells whether the serial number verification is enabled.  
0: Not selected.  
1: Setting = Actual device  
Serial numbers are verified only for NX Units (not for EtherCAT Coupler Units).

Index (hex)	Subindex (hex)	Object name	Default	Data range	Unit	Data type	Access	I/O allocation	Data attribute
4007	---	Error Detection Setting of NX Unit	---	---	---	---	---	---	---
	00	Number of Entries	2	2	---	USINT	RO	Not possible.	---
	02	NX Unit Connection Wait Time	3	3 to 200	s	UINT	RW	Not possible.	Y

- Subindex 02 hex gives the wait time to monitor for connection of the NX Units.

Index (hex)	Subindex (hex)	Object name	Default	Data range	Unit	Data type	Access	I/O allocation	Data attribute
400A	---	Preventing Incorrect Operation Setting	---	---	---	---	---	---	---
	00	Number of Entries	2	2	---	USINT	RO	Not possible.	---
	01	USB Connection Prohibition Setting	0	0 or 1	---	USINT	RW	Not possible.	N

- Subobject 01 hex specifies whether to prohibit Sysmac Studio online connections through the peripheral USB port on the EtherCAT Coupler Unit. Set subindex 01 to *Enable* to prohibit the connection.

0: Disable

1: Enable

Refer to *11-12 Prohibiting USB Connections* on page 11-45 for details on prohibiting USB connections.

Index (hex)	Subindex (hex)	Object name	Default	Data range	Unit	Data type	Access	I/O allocation	Data attribute
400D	---	Fail-soft Operation Setting	---	---	---	---	---	---	---
	00	Number of Entries	2	2	---	USINT	RO	Not possible.	---
	01	Fail-soft Operation Setting	1	0 or 1	---	USINT	RW	Not possible.	Y

- Subindex 01 hex specifies whether to use fail-soft operation for the EtherCAT Slave Terminal. Set subindex 01 to *Fail-soft operation* to use fail-soft operation.

0: Fail-soft operation

1: Stop

Refer to *11-11 Fail-soft Operation* on page 11-41 for details on fail-soft operation.

Index (hex)	Subindex (hex)	Object name	Default	Data range	Unit	Data type	Access	I/O allocation	Data attribute
5000	---	Communications Error Setting	---	---	---	---	---	---	---
	00	Number of Entries	1	1	---	USINT	RO	Not possible.	---
	01	Consecutive Communications Error Detection Count	1	0 to 15	---	USINT	RW	Not possible.	Y

- Subindex 01 hex sets the number of consecutive communications errors to detect before generating a communications data error. A Communications Synchronization Error occurs when the number of consecutive communications errors exceeds this setting.



### Precautions for Safe Use

When you use an NJ/NX-series CPU Unit with the cable redundancy function in DC Mode, set the Communications Error Setting set value for EtherCAT slaves in DC Mode to the following value. If the communications cable is disconnected or the power supply of the EtherCAT slaves is turned OFF with the Communications Error Setting set value set to any other value, communications may discontinue due to a Communications Synchronization Error.

Project unit version 1.42 or later: 2 or higher

Project unit version earlier than 1.42: 1 (default value) or higher

Index (hex)	Subindex (hex)	Object name	Default	Data range	Unit	Data type	Access	I/O allocation	Data attribute
5001	---	Sync Not Received Timeout Setting	---	---	---	---	---	---	---
	00	Number of Entries	1	1	---	USINT	RO	Not possible.	---
	01	Sync Error Monitoring Time	0	0 to 600	s	UINT	RW	Not possible.	Y

- Subindex 01 sets the time until a synchronization error is generated. A Synchronization Error occurs if the first SYNC0 signal input does not turn ON within this set time after the EtherCAT Coupler Unit enters the Safe-Operational state.  
A value of 0 implies 120 s.

# A-9 Terminal Block Model Numbers

This section describes the models of screwless clamping terminal blocks for the EtherCAT Coupler Units and NX Units.

## A-9-1 Model Number Notation

The terminal block model numbers are assigned based on the following rules.

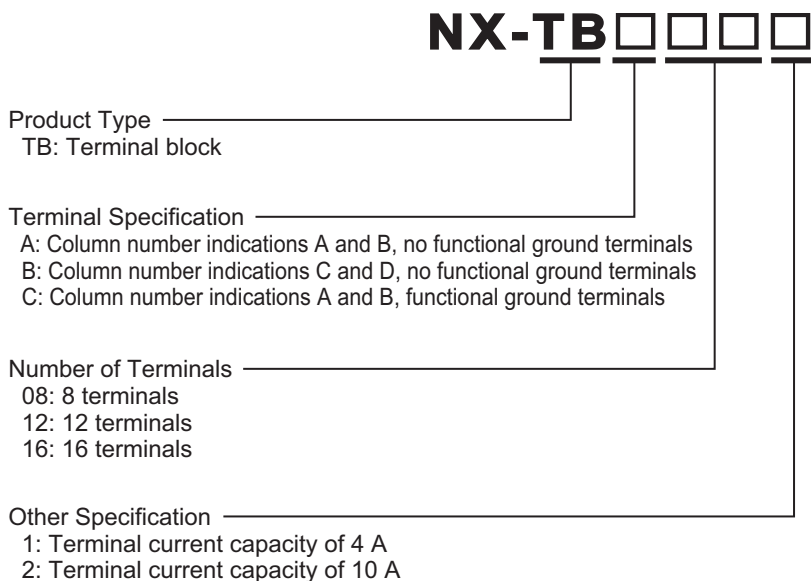

## A-9-2 Models

The following table lists the terminal blocks.

Refer to *4-5 Terminal Blocks* on page 4-15 for the terminal blocks that are applicable to the EtherCAT Coupler Unit.

Terminal block model number	Number of terminals	Ground terminal mark	Terminal current capacity
NX-TBA081	8	None	4 A
NX-TBA121	12	None	4 A
NX-TBA161	16	None	4 A
NX-TBB121	12	None	4 A
NX-TBB161	16	None	4 A
NX-TBA082	8	None	10 A
NX-TBA122	12	None	10 A
NX-TBA162	16	None	10 A
NX-TBB082	8	None	10 A
NX-TBB122	12	None	10 A
NX-TBB162	16	None	10 A
NX-TBC082	8	Provided	10 A
NX-TBC162	16	Provided	10 A

**Note** When you purchase a terminal block, purchase an NX-TB□□□2.

# A-10 Functional Restrictions by Model

The functions supported by EtherCAT Coupler Units depend the model number of the EtherCAT Coupler Unit. There are also functional restrictions depending on the unit version.

Functional restrictions and support are given for each model in the following table.

Function		NX-ECC201	NX-ECC202	NX-ECC203
Setting Slave Terminals		Supported.		
Cyclic I/O Refreshing	Free-Run Refreshing	Supported.		
	Synchronous I/O Refreshing	Supported.		
	Task Period Prioritized Refreshing	Not supported.		Supported.
	Time Stamp Refreshing	Restricted.	Supported.	
NX Unit Mounting Settings		Supported.		
Sysmac Device Functionality Unique to EtherCAT Slaves	Troubleshooting with Error Notification through Sysmac Error Status	Supported.		
	Saving Node Address Settings	Supported.		
	Verifying the EtherCAT Network Configuration Using Serial Numbers	Supported.		
	SII Data Checking	Supported.		
Security	Operation Authority Verification	Supported.		
Event Logs		Supported.		
Clearing All Memory		Restricted.	Supported.	
Restarting		Restricted.	Supported.	
Changing Event Levels		Supported.		
Resetting Errors		Supported.		
I/O Checking		Restricted.	Supported.	
Fail-soft Operation		Restricted.	Supported.	
Prohibiting USB Connections		Restricted.	Supported.	
Monitoring Total Power-ON Time		Restricted.	Supported.	

Refer to *A-11-2 Functions That Were Added or Changed for Each Unit Version* on page A-103 for details on the restrictions on functionality for different unit versions of the EtherCAT Coupler Units.

Some support functions of the EtherCAT Coupler Units are restricted depending on the models of the NX Units and unit versions. Refer to *Support Functions of the Communications Coupler Units and Restrictions on the NX Units* of the *NX-series Data Reference Manual (Cat. No. W525)* for support functions of the EtherCAT Coupler Units and restrictions on the NX Units.

# A-11 Version Information

This section describes the relationship between the unit versions of the EtherCAT Coupler Units, the unit versions of the NJ/NX-series CPU Units, the unit versions of the NY-series Industrial PCs, and the versions of the Sysmac Studio.

## A-11-1 Relationship between Unit Versions

The following table shows the relationship between the unit version of the EtherCAT Coupler Unit, the unit version of the CPU Unit, the unit version of the Industrial PC, and the version of the Sysmac Studio. If you use any of the combinations of versions/unit versions that are the same or that are later or higher than the corresponding versions given in the following table, you can use all of the functions that are supported by that unit version of the EtherCAT Coupler Unit. Refer to *A-11-2 Functions That Were Added or Changed for Each Unit Version* on page A-103 for the functions that are supported for each unit version of the EtherCAT Coupler Unit.

Depending on the type and model of the Unit, some Units do not have all of the versions given in the corresponding versions. If a Unit does not have the specified version, support is provided by the oldest available version after the specified version. Refer to Version Information in the user's manuals for the specific Units for the relation between models and versions.

Refer to version-related information on the CPU Unit or Industrial PC for corresponding versions when using CPU Unit versions, Industrial PC unit versions, and Sysmac Studio versions that are the same or that are later or higher than the corresponding versions given in the following table.

EtherCAT Coupler Unit		Corresponding unit version/version					
Model	Unit version	Using an NX-series CPU Unit		Using an NJ-series CPU Unit		Using an NY-series Industrial PC	
		Unit version of CPU Unit	Sysmac Studio version	Unit version of CPU Unit	Sysmac Studio version	Unit version of Industrial PC	Sysmac Studio version
NX-ECC201	Ver.1.2	Ver.1.10	Ver.1.12	Ver.1.07	Ver.1.08	Ver.1.12	Ver.1.17
	Ver.1.1			Ver.1.06	Ver.1.07		
	Ver.1.0			Ver.1.05	Ver.1.06		
NX-ECC202	Ver.1.2*1			Ver.1.07	Ver.1.08		
NX-ECC203	Ver.1.7		Ver.1.41		Ver.1.41		Ver.1.41
	Ver.1.6		Ver.1.25		Ver.1.25		Ver.1.25
	Ver.1.5		Ver.1.19		Ver.1.19		Ver.1.19
	Ver.1.4		Ver.1.16		Ver.1.16		Ver.1.17
	Ver.1.3*2		Ver.1.12		Ver.1.12		

\*1. For the NX-ECC202, there is no unit version of 1.1 or earlier.

\*2. For the NX-ECC203, there is no unit version of 1.2 or earlier.



### Precautions for Correct Use

On the Select Device Area of the Project Properties Dialog Box on the Sysmac Studio, select version 1.05 or later for the NJ-series CPU Unit version. You cannot use the EtherCAT Coupler Unit if you select version 1.04 or earlier for the unit version.

## A-11-2 Functions That Were Added or Changed for Each Unit Version

This section gives the functions that were added or changed for each unit version of the EtherCAT Coupler Unit.

### Changes in and Additions to Functions

The following table shows the unit version of the EtherCAT Coupler Unit, the unit version of the CPU Unit, the unit version of the Industrial PC, and the version of the Sysmac Studio for changes in or additions to the functions.

You can also use the added or changed functions with the versions/unit versions given in the table or with later/higher versions.

Refer to version-related information on the CPU Unit or Industrial PC for corresponding versions when using CPU Unit versions, Industrial PC unit versions, and Sysmac Studio versions that are the same or that are later or higher than the corresponding versions given in the following table.

Depending on the type and model of the Unit, some Units do not have all of the versions given in the corresponding versions. If a Unit does not have the specified version, support is provided by the oldest available version after the specified version. Refer to Version Information in the user's manuals for the specific Units for the relation between models and versions.

#### ● NX-ECC201

The following table shows the relationship when the CPU Unit is connected.

Function		Change or addition	Ether-CAT Coupler Unit	Corresponding unit version/version				NX Unit restrictions
				Using an NX-series CPU Unit		Using an NJ-series CPU Unit		
				CPU Unit	Sysmac Studio	CPU Unit	Sysmac Studio	
Changing the model of an EtherCAT Coupler Unit		Addition	Ver.1.0	Ver.1.10	Ver.1.13	Ver.1.05	Ver.1.09	None
Restarting	Restarting a specified NX Unit	Addition	Ver.1.2			Ver.1.07*1	Ver.1.08	Yes
I/O checking		Addition	Ver.1.2			Ver.1.05	Ver.1.08	Yes
Fail-soft operation		Addition	Ver.1.2			Ver.1.05	Ver.1.08	None
Prohibiting USB connections		Addition	Ver.1.2			Ver.1.05	Ver.1.08	None
Monitoring total power-ON time*2		Addition	Ver.1.2			Ver.1.05	Ver.1.08	Yes
Restarting after Clear All Memory operation	Restarting only the specified NX Unit after performing the Clear All Memory operation for a specified NX Unit	Change	Ver.1.2			Ver.1.05	Ver.1.08	Yes
Restarting after transferring Unit operation settings	Restarting the NX Unit to which the Unit operation settings were transferred when you transfer the settings to a specified NX Unit*3	Change	Ver.1.2			Ver.1.05	Ver.1.08	Yes
Uploading Slave Terminal settings through the USB port on the EtherCAT Coupler Unit		Addition	Ver.1.0			Ver.1.05	Ver.1.08	None
I/O refreshing methods	Time stamp refreshing Input refreshing with input changed times Output refreshing with specified time stamps	Addition	Ver.1.1			Ver.1.06*4	Ver.1.07	Yes

- \*1. An NJ-series CPU Unit with unit version 1.07 or later is required to specify an NX Unit for the restart instruction. If you do not specify an NX Unit with the restart instruction, you can use version 1.05. Refer to the *NJ/NX-series Instructions Reference Manual (Cat. No. W502)* for information on specifying an NX Unit for the restart instruction.
- \*2. The instruction to read the total power ON time is supported by an NJ-series CPU Unit with version 1.10 or later, or an NX-series CPU Unit.
- \*3. This applies when there are changes to the Unit operation settings that require restarting the Unit.
- \*4. The instructions for time stamp refreshing are supported by NJ-series CPU Units with unit version 1.06 or later. If you do not use instructions for time stamp refreshing, you can use version 1.05. Refer to the *NJ/NX-series Instructions Reference Manual (Cat. No. W502)* for information on the instructions for time stamp refreshing.

The following table shows the relationship when the Industrial PC is connected.

Function	Change or addition	EtherCAT Coupler Unit	Corresponding unit version/ version		NX Unit restrictions
			Using an NY-series Industrial PC		
			Industrial PC	Sysmac Studio	
Changing the model of an EtherCAT Coupler Unit	Addition	1.0	Ver.1.12	Ver.1.16	None
Restarting Restarting a specified NX Unit	Addition	Ver.1.2			Yes
I/O checking	Addition	Ver.1.2			Yes
Fail-soft operation	Addition	Ver.1.2			None
Prohibiting USB connections	Addition	Ver.1.2			None
Monitoring total power-ON time	Addition	Ver.1.2			Yes
Restarting after Clear All Memory operation	Restarting only the specified NX Unit after performing the Clear All Memory operation for a specified NX Unit	Change	Ver.1.2		Yes
Restarting after transferring Unit operation settings	Restarting the NX Unit to which the Unit operation settings were transferred when you transfer the settings to a specified NX Unit*1	Change	Ver.1.2		Yes
Uploading Slave Terminal settings through the USB port on the EtherCAT Coupler Unit	Addition	Ver.1.0			None
I/O refreshing methods	Time stamp refreshing Input refreshing with input changed times Output refreshing with specified time stamps	Addition	Ver.1.1		Yes

\*1. This applies when there are changes to the Unit operation settings that require restarting the Unit.

Refer to *Support Functions of the Communications Coupler Units and Restrictions on the NX Units of the NX-series Data Reference Manual (Cat. No. W525)* for the restrictions on NX Units. Refer to *A-10 Functional Restrictions by Model* on page A-101 for the functions supported by this model.

● **NX-ECC202**

There are no unit version updates. Therefore, functionality is not added or changed. Refer to *A-10 Functional Restrictions by Model* on page A-101 for the functions supported by this model.

● **NX-ECC203**

The following table shows the relationship when the CPU Unit is connected.

Function	Change or addition	Ether-CAT Coupler Unit	Corresponding unit version/version				NX Unit restrictions
			Using an NX-series CPU Unit		Using an NJ-series CPU Unit		
			CPU Unit	Sysmac Studio	CPU Unit	Sysmac Studio	
<ul style="list-style-type: none"> <li>Added the attached information to the synchronization error event</li> <li>The following events are no longer registered in the event log<sup>*1</sup> NX Unit Minor Fault NX Unit Observation</li> </ul>	Change	Ver.1.7	Ver.1.10	Ver.1.41	Ver.1.07	Ver.1.41	None
Support for the cable redundancy function <sup>*2</sup> (Minimum value of the communications cycle: 125 μs) <sup>*3</sup>	Change	Ver.1.6	Ver.1.40 <sup>*4*5</sup>	Ver.1.29	Ver.1.40 <sup>*4*5</sup>	Ver.1.29	None
CoE objects <ul style="list-style-type: none"> <li>Sync Manager 2 Synchronization (index 1C32 hex)</li> <li>Sync Manager 3 Synchronization (index 1C33 hex)</li> <li>Default and data range of Number of Synchronization Parameters</li> <li>Subindex number of Cycle Time Too Small</li> </ul>	Change	Ver.1.6	Ver.1.10	Ver.1.25	Ver.1.07	Ver.1.25	None

Function	Change or addition	Ether-CAT Coupler Unit	Corresponding unit version/version				NX Unit restrictions
			Using an NX-series CPU Unit		Using an NJ-series CPU Unit		
			CPU Unit	Sysmac Studio	CPU Unit	Sysmac Studio	
CoE objects <ul style="list-style-type: none"> <li>• Store Parameters (index 1010 hex)</li> <li>• Restore Default Parameters (index 1011 hex)</li> <li>• Diagnosis History (index 10F3 hex)</li> <li>• Present Time for Event Log (index 10F9 hex)</li> <li>• Coupler Unit Current Errors (index 3809 hex)</li> <li>• Coupler Unit Event Log (index 380A hex)</li> <li>• Switch Parameter Write Mode (index 380B hex)</li> <li>• Coupler Unit Total Power-On Time (index 380C hex)</li> <li>• NX Unit Total Power-On Time (index 380D hex)</li> <li>• NX Unit Restart (index 380E hex)</li> <li>• Store Parameters Command (index 380F hex)</li> <li>• Restore Default Parameters Command (index 3810 hex)</li> <li>• NX Unit Current Errors (index 4010 + (NX Unit number - 01) x 20))</li> <li>• NX Unit Event Log (index 4011 + (NX Unit number - 01) x 20))</li> <li>• NX Unit Event Log Clear (index 4012 + (NX Unit number - 01) x 20))</li> <li>• Editing Unit operation settings for NX Units (index 5000 + (NX Unit number - 01) x 20))</li> </ul>	Addition	Ver.1.5	Ver.1.10	Ver.1.19	Ver.1.07	Ver.1.19	Yes
Support for the cable redundancy function*2 (Minimum value of the communications cycle: 250 μs)*3	Addition	Ver.1.5	Ver.1.40*4*5	Ver.1.29	Ver.1.40*4*5	Ver.1.29	None

- \*1. The following events are reported as current errors, but are not registered in the event log.  
 NX Unit Minor Fault  
 NX Unit Observation  
 Therefore, check and troubleshoot the errors for the NX Unit that caused these events.
- \*2. The cable redundancy function can be realized by configuring a ring topology. The support of ring topology depends on the specifications of the connected EtherCAT master. Confirm the specifications of the connected EtherCAT master.
- \*3. If the slave device is operated at a cycle shorter than the minimum value of the communications cycle, the EtherCAT frame may be lost or the communications may be disabled.
- \*4. Ring topology cannot be configured with CPU Unit models that do not have the specified versions or later. For unit versions of CPU Units, refer to *Version Information* in the user's manual of the connected CPU Unit.
- \*5. The cable redundancy function of the built-in EtherCAT port on a CPU Unit can be used with project unit version 1.40 or later in the Sysmac Studio project. It cannot be used with project unit version earlier than 1.40.

The following table shows the relationship when the Industrial PC is connected.

Function	Change or addition	EtherCAT Coupler Unit	Corresponding unit version/ version		NX Unit restrictions
			Using an NY-series Industrial PC		
			Industrial PC	Sysmac Studio	
<ul style="list-style-type: none"> <li>Added the attached information to the synchronization error event</li> <li>The following events are no longer registered in the event log*<sup>1</sup> NX Unit Minor Fault NX Unit Observation</li> </ul>	Change	Ver.1.7	Ver.1.12	Ver.1.41	None
Support for the cable redundancy function* <sup>2</sup> (Minimum value of the communications cycle: 125 μs)* <sup>3</sup>	Change	Ver.1.6	Not possible.	Not possible.	None.
CoE objects <ul style="list-style-type: none"> <li>Sync Manager 2 Synchronization (index 1C32 hex)</li> <li>Sync Manager 3 Synchronization (index 1C33 hex)</li> </ul> Default and data range of Number of Synchronization Parameters Subindex number of Cycle Time Too Small	Change	Ver.1.6	Ver.1.12	Ver.1.25	None

Function	Change or addition	EtherCAT Coupler Unit	Corresponding unit version/ version		NX Unit restrictions
			Using an NY-series Industrial PC		
			Industrial PC	Sysmac Studio	
CoE objects <ul style="list-style-type: none"> <li>• Store Parameters (index 1010 hex)</li> <li>• Restore Default Parameters (index 1011 hex)</li> <li>• Diagnosis History (index 10F3 hex)</li> <li>• Present Time for Event Log (index 10F9 hex)</li> <li>• Coupler Unit Current Errors (index 3809 hex)</li> <li>• Coupler Unit Event Log (index 380A hex)</li> <li>• Switch Parameter Write Mode (index 380B hex)</li> <li>• Coupler Unit Total Power-On Time (index 380C hex)</li> <li>• NX Unit Total Power-On Time (index 380D hex)</li> <li>• NX Unit Restart (index 380E hex)</li> <li>• Store Parameters Command (index 380F hex)</li> <li>• Restore Default Parameters Command (index 3810 hex)</li> <li>• NX Unit Current Errors (index 4010 + (NX Unit number - 01) x 20))</li> <li>• NX Unit Event Log (index 4011 + (NX Unit number - 01) x 20))</li> <li>• NX Unit Event Log Clear (index 4012 + (NX Unit number - 01) x 20))</li> <li>• Editing Unit operation settings for NX Units (index 5000 + (NX Unit number - 01) x 20))</li> </ul>	Addition	Ver.1.5	Ver.1.12	Ver.1.19	Yes
Cable redundancy function*2 (Minimum value of the communications cycle: 250 μs)*3	Addition	Ver.1.5	Not possible.	Not Possible.	None
Communications support in DC Mode for the following EtherCAT masters*4 <ul style="list-style-type: none"> <li>• CK3E-□□□□</li> <li>• NY512-A600-1XX□13910</li> </ul>	Addition	Ver.1.4	Ver.1.12	Ver.1.16	None

\*1. The following events are reported as current errors, but are not registered in the event log.  
 NX Unit Minor Fault  
 NX Unit Observation  
 Therefore, check and troubleshoot the errors for the NX Unit that caused these events.

\*2. The cable redundancy function can be realized by configuring a ring topology. The support of ring topology depends on the specifications of the connected EtherCAT master. Confirm the specifications of the connected EtherCAT master.

\*3. If the slave device is operated at a cycle shorter than the minimum value of the communications cycle, the EtherCAT frame may be lost or the communications may be disabled.

\*4. Refer to the connection guide for the appropriate EtherCAT master for details on how to use EtherCAT Slave Terminals with these EtherCAT masters.

Refer to *Support Functions of the Communications Coupler Units and Restrictions on the NX Units* of the *NX-series Data Reference Manual (Cat. No. W525)* for the restrictions on NX Units. Refer to *A-10 Functional Restrictions by Model* on page A-101 for the functions supported by this model.

## **Addition of Connectable NX Units**

---

Additions are sometimes made to the NX Units that you can connect to an EtherCAT Coupler Unit when the unit version of the EtherCAT Coupler Unit is upgraded.

For the NX Units that you can connect to an EtherCAT Coupler Unit, refer to *Version Information with Communications Coupler Units* in the *NX-series Data Reference Manual (Cat. No. W525)*.



# Index



# Index

## Numerics

_node5UnitErr.....	9-40
_node5UnitMsg.....	9-40
_node5UnitRun.....	9-40
35-mm DIN Track.....	6-6

## A

access.....	A-34, A-89
accessory.....	3-5
active configuration.....	A-13
Additional I/O Power Supply Unit.....	5-4
Additional NX Unit Power Supply Unit.....	5-3
AL status.....	13-60
AL status codes.....	13-60
allocatable I/O data points.....	9-15
Analog I/O Units.....	2-8
angle for insertion.....	7-17, 7-20
Applicable Wire.....	7-13
application objects.....	8-6
assignable tasks.....	10-22
assigning axis variables.....	9-3, 9-37, 9-40
assigning device variables.....	9-3, 9-37
attaching a terminal block.....	7-22

## B

backing up.....	9-48
backing up settings.....	9-47
blocks.....	5-17

## C

calculating the effective value.....	5-15
CAN application protocol over EtherCAT.....	8-2
changing event levels.....	11-29
changing the model of an EtherCAT Coupler Unit or NX Unit.....	9-15, 9-32
changing the unit configuration.....	9-51
checking the wiring.....	3-12
clearing all memory.....	11-23
clock information.....	11-18
Coding Pin.....	7-23
CoE objects.....	A-31
communications cable.....	2-7
communications connectors.....	4-2, 4-14
Communications Coupler Unit.....	1-6
communications cycle.....	8-10
Communications Interface Unit.....	2-8
comparing and merging with actual unit configuration of the Slave Terminal.....	9-29
comparing settings.....	9-45
complete access.....	A-34
configuration width of an EtherCAT Slave Terminal.....	6-21
crimping tool.....	7-13

current errors.....	13-13
---------------------	-------

## D

data attribute.....	A-34, A-89
data type.....	A-31, A-89
DC Mode.....	8-10, 10-6
DC time.....	10-6
default.....	A-34, A-89
device name.....	9-7, 9-11
Digital I/O Units.....	2-8
DIN Track contact plate.....	4-2, 4-17
DIN Track insulation spacers.....	7-11
DIN Track mounting hooks.....	4-2, 4-4
DIN Tracks.....	6-7
DIP switch.....	4-2, 4-12
displaying the transmission delay times of the EtherCAT master.....	9-34

## E

Edit Slave Terminal Configuration Tab Page.....	9-12
emergency error codes.....	13-57
emergency messages.....	13-56
enable distributed clock.....	9-8
enable/disable settings.....	9-7
End Plate.....	6-6
ENI.....	A-13
error logs.....	13-56
error table.....	13-14
ESI (EtherCAT Slave Information) file.....	2-7
EtherCAT Configuration Edit Tab Page.....	9-9
EtherCAT Coupler Unit.....	2-6
EtherCAT master.....	2-6
EtherCAT slave information.....	8-3
EtherCAT Slave Terminals.....	1-6
event codes.....	11-17
event levels.....	11-18
event logs.....	11-15
event sources.....	11-17
exporting the EtherCAT network configuration information.....	9-10
exporting the EtherCAT Slave Terminal configuration information.....	9-14
exporting/importing Slave Terminal settings and NX Unit settings.....	9-30
external power supplies.....	5-16

## F

fail-soft operation.....	11-41
Ferrule.....	7-13
Free-Run Mode.....	8-10, 10-7
Free-Run refreshing.....	10-9
functional ground terminal.....	4-17
functional ground terminals.....	7-8

**G**

getting NX Unit serial numbers.....	9-30
going online.....	2-10
ground resistance of 100 Ω or less.....	7-10
Ground terminal.....	7-14, 7-15
ground terminal mark.....	4-15
ground terminals.....	7-8

**H**

hardware switch.....	4-11
----------------------	------

**I**

I/O allocation.....	A-89
I/O allocation information.....	9-15
I/O allocation settings.....	8-7, 9-11
I/O Allocation Status.....	9-25
I/O checking.....	11-35
I/O data.....	9-16
I/O data size.....	9-15
I/O entries.....	8-7, 9-16
I/O entry mapping.....	8-7, 9-15
I/O entry mapping list.....	9-25
I/O power supply.....	5-3, 5-18
I/O Power Supply Connection Unit.....	5-5
I/O power supply terminals.....	7-7
I/O refreshing.....	10-2
I/O Refreshing Mode.....	10-6
I/O response times.....	12-2
incorrect attachment prevention hole.....	7-25
index.....	8-6, A-34, A-89
indicators.....	4-2, 4-4
Init.....	8-4
input port.....	7-5
input prioritized refreshing.....	10-8
input refreshing with input changed times.....	10-9
inrush current.....	5-18
installation dimensions.....	6-20
installation height.....	6-22
installation in cabinets or control panels.....	6-2
installation locations for protective devices.....	5-21
installation method in control panels.....	6-3
installation orientation.....	6-8
IO-Link Master Unit.....	2-8

**L**

Load Cell Input Unit.....	2-8
log of the errors.....	13-13

**M**

mailbox communications.....	1-4
marker attachment locations.....	4-2, 4-4
maximum I/O power supply current.....	5-11
meaning of error.....	13-20
message response time.....	12-36
minor fault.....	11-18

model number.....	4-6
monitoring total power-ON time.....	11-47
mounting the EtherCAT Slave Terminal on DIN Track.....	6-3

**N**

New Messages Available.....	9-23
node address.....	4-13, 9-7
number of connectable NX Units.....	3-2
number of I/O entry mappings.....	9-15
number of tasks to assign.....	10-22
NX bus connector.....	4-2, 4-4
NX objects.....	A-89
NX Unit.....	2-7
NX Unit connection time.....	9-11
NX Unit Error Status.....	9-22
NX Unit I/O Data Active Status.....	9-21
NX Unit Message Enabled Status.....	9-21
NX Unit mounting setting.....	9-11, 11-6
NX Unit number.....	9-11
NX Unit power.....	5-2
NX Unit power supply capacity.....	5-7
NX Unit power supply capacity and restrictions.....	5-7
NX Unit Registration Status.....	9-20

**O**

object dictionary.....	8-2
object dictionary area.....	A-31
object name.....	A-34, A-89
observation.....	11-18
operation authority verification.....	11-13
operation for task period prioritized refreshing.....	10-12
operation of Free-Run refreshing.....	10-17
operation of input refreshing with input changed times.....	10-15
operation of output refreshing with specified time stamps.....	10-15
operation of synchronous I/O refreshing.....	10-10
operation of time stamp refreshing.....	10-15
operation with input prioritized refreshing.....	10-12
operation with output prioritized refreshing.....	10-13
Operational.....	8-4
output port.....	7-5
output prioritized refreshing.....	10-8
output refreshing with specified time stamps.....	10-9
overcurrent.....	5-20

**P**

PDO.....	8-2
PDO communications.....	1-4
PDO groups.....	A-13
PDO mapping.....	A-34
PDO mapping objects.....	8-5, 8-6
PDO mappings.....	8-6
Periodic Inspection Item.....	14-2
peripheral USB port.....	4-2, 4-14
Position Interface Units.....	2-8
power supply-related unit.....	5-3
Pre-Operational.....	8-4

Preventing Incorrect Attachment.....	7-22
primary period.....	10-3
primary periodic task.....	10-3, 10-4
priority-5 periodic task.....	10-3
process data communications.....	1-4
process data communications cycle.....	10-2
process data communications cycle 1.....	10-3
process data communications cycle 2.....	10-3
process data objects.....	8-2
programming sample.....	9-40
prohibiting USB connections.....	11-45
protective devices.....	5-20
protrusions for removing the unit.....	4-2, 4-4, 4-5

## R

recommended power supplies.....	5-16, 5-18
refresh cycle of each NX Unit.....	10-2
refresh cycle of the NX bus.....	10-2
release holes.....	4-15
removing a terminal block.....	7-21
resetting errors.....	11-31
restarting.....	11-26
restarting individual NX Units.....	11-27
restarting Slave Terminal.....	11-26
restricted region.....	6-9, 6-12
restrictions on inrush current.....	5-14
revision.....	9-7
RJ45 connectors.....	7-2
rotary switches.....	4-3, 4-11
RxPDO.....	8-5

## S

Safe-Operational.....	8-4
safety control system.....	2-9
Safety Control Units.....	2-8
Safety CPU Unit.....	2-8
Safety I/O Unit.....	2-8
SD Memory Card backup function.....	9-47
SDO.....	8-2
SDO communications.....	1-4
Securing Wires.....	7-18
security.....	11-13
selecting protective devices.....	5-20
send/receive PDO data sizes.....	3-3
serial number check method.....	9-11
service data objects.....	8-2
setting parameter.....	9-8
setting parameters.....	9-8
setting the task periods of periodic tasks.....	10-18
SII.....	11-12
size.....	A-34
Solid Wire.....	7-14
special instructions.....	12-36, A-10
subindex.....	A-34, A-89
supply from external source.....	5-9
supply from the NX bus.....	5-9
Sync0.....	8-10, 10-6
synchronous I/O refreshing.....	10-8

Sysmac device functionality.....	11-11
Sysmac error status.....	9-23, 13-55
Sysmac Studio.....	2-7
Sysmac Studio Controller backup function.....	9-48
System Units.....	2-8

## T

task period of the periodic task.....	10-2
task period prioritized refreshing.....	10-8
task period warning.....	10-19, 10-20
Temperature Control Unit.....	2-8
terminal block.....	4-2, 4-4, 4-15
terminal holes.....	4-15
terminal number indications.....	4-15
through-wiring.....	7-7
time stamp refreshing.....	10-8
Time Stamps of Synchronous I/O Refresh.....	9-22
total power-ON time.....	11-47
transferring settings.....	9-42
troubleshooting.....	13-12
Twisted Wire.....	7-14
twisted-pair cable.....	7-2
TxPDO.....	8-5

## U

unit.....	A-34, A-89
Unit application data.....	9-28
Unit configuration information.....	9-10
Unit hookup guides.....	4-2, 4-4, 4-5
Unit operation settings.....	9-11, 9-26
Unit power supply.....	5-2, 5-16
Unit power supply terminals.....	7-7
unit specifications.....	4-2, 4-4
unit versions.....	A-102
unmounted unit.....	11-8
unwired terminals.....	7-7
uploading Slave Terminal settings.....	9-32

## V

version of the Sysmac Studio.....	A-102
voltage drop in the I/O power supply.....	5-10, 5-13

## W

wiring ducts.....	6-4
-------------------	-----



**OMRON Corporation Industrial Automation Company**

**Kyoto, JAPAN**

**Contact : [www.ia.omron.com](http://www.ia.omron.com)**

**Regional Headquarters**

**OMRON EUROPE B.V.**

Wegalaan 67-69, 2132 JD Hoofddorp  
The Netherlands  
Tel: (31) 2356-81-300 Fax: (31) 2356-81-388

**OMRON ELECTRONICS LLC**

2895 Greenspoint Parkway, Suite 200  
Hoffman Estates, IL 60169 U.S.A.  
Tel: (1) 847-843-7900 Fax: (1) 847-843-7787

**OMRON ASIA PACIFIC PTE. LTD.**

438B Alexandra Road, #08-01/02 Alexandra  
Technopark, Singapore 119968  
Tel: (65) 6835-3011 Fax: (65) 6835-3011

**OMRON (CHINA) CO., LTD.**

Room 2211, Bank of China Tower,  
200 Yin Cheng Zhong Road,  
PuDong New Area, Shanghai, 200120, China  
Tel: (86) 21-6023-0333 Fax: (86) 21-5037-2388

**Authorized Distributor:**

©OMRON Corporation 2012 - 2025 All Rights Reserved.  
In the interest of product improvement,  
specifications are subject to change without notice.

**Cat. No. W519-E1-18 1025**